

# 4. přenáška

---

## **Konfigurace hlasových portů na směrovačích Cisco**





# Opakování – zadání příkladu

---

Vypočtete přenosovou rychlost:

- Ethernet
- IPv4
- UDP
- RTP
- Kodek G.729
- Intenzita vysílání: 1 za 20 ms

# Výpočet

---

Vypočtete přenosovou rychlost:

- Ethernet: 18 B
- IPv4: 20 B
- UDP: 8 B
- RTP: 12 B
- Kodek G.729: 20 B

Celkem:

78 B tj. 624 bitů \* 50 paketů/s = 31,2 kb/s

# K čemu je doplnění na násobky 8 u RTP pro GSM?

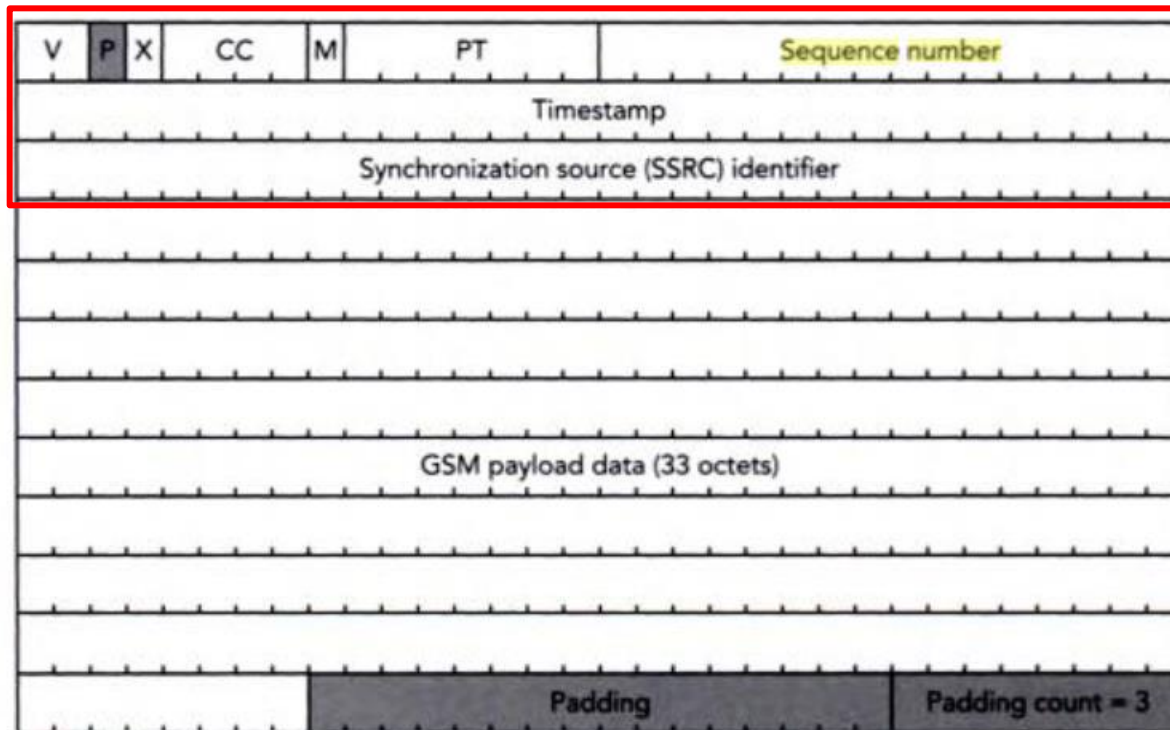

Záhlaví RTP

# Pro šifrovací bloky na 8 B

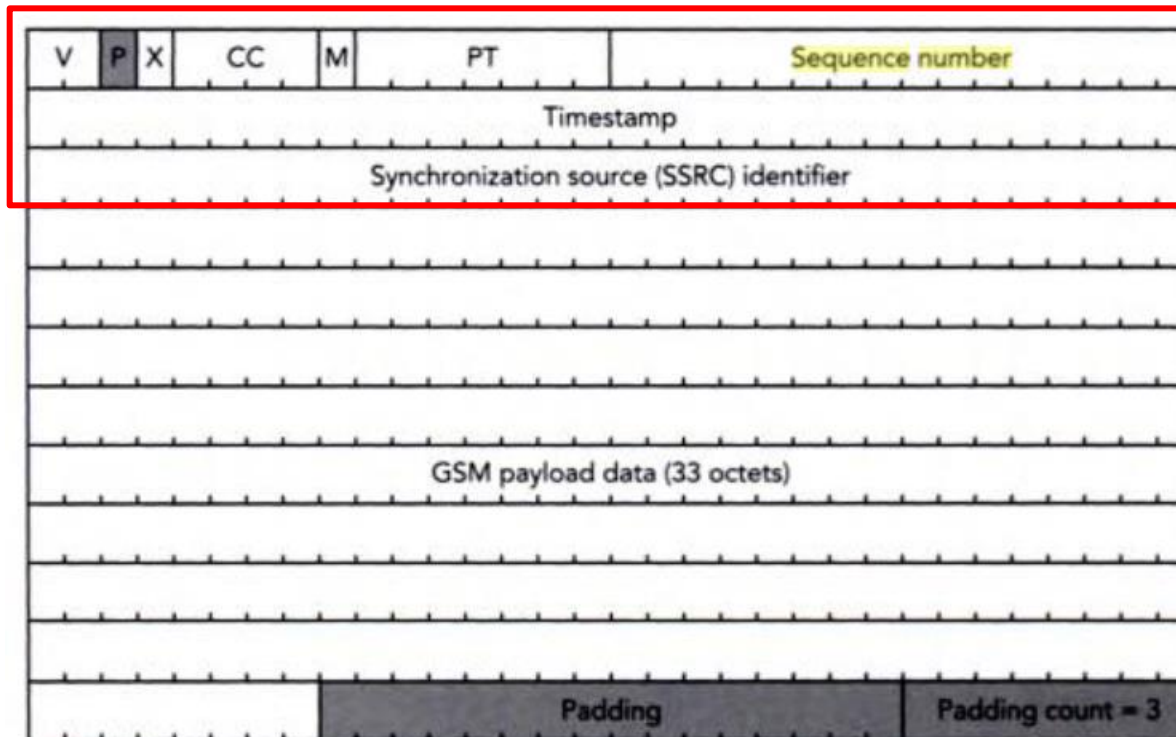

Záhlaví RTP

# Co je zde přenášeno?

User Datagram Protocol, Src Port: alchemy (3234), Dst Port: alchemy (3234)

Real-Time Transport Protocol

⊕ [Stream setup by SDP (frame 8)]

10.. .... = Version: RFC 1889 Version (2)

..0. .... = Padding: False

...0 .... = Extension: False

.... 0000 = Contributing source identifiers count: 0

0... .... = Marker: False

Payload type: DynamicRTP-Type-100 (100)

Sequence number: 0

[Extended sequence number: 65536]

Timestamp: 5081566

Synchronization Source identifier: 0xe2a51901 (3802470657)

RFC 2833 RTP Event

Event ID: DTMF Zero 0 (0)

0... .... = End of Event: False

.1.. .... = Reserved: True

..10 0001 = Volume: 33

Event Duration: 768



# Které pakety jsou zde přenášeny?

```
Internet Protocol Version 4, Src: 192.168.16.23 (192.168.16.23), Dst: 192.168.16.24
User Datagram Protocol, Src Port: murx (2743), Dst Port: igcp (2801)
Real-time Transport Control Protocol (Sender Report)
```

```
⊕ [Stream setup by H245 (frame 597)]
  10.. .... = Version: RFC 1889 Version (2)
  ..0. .... = Padding: False
  ...0 0001 = Reception report count: 1
  Packet type: Sender Report (200)
  Length: 12 (52 bytes)
  Sender SSRC: 0x196d27c5 (426584005)
  Timestamp, MSW: 81 (0x00000051)
  Timestamp, LSW: 3380122050 (0xc97891c2)
  [MSW and LSW as NTP timestamp: Not representable]
  RTP timestamp: 1025641874
  Sender's packet count: 599
  Sender's octet count: 95840
```

```
⊕ Source 1
Real-time Transport Control Protocol (Source description)
[RTCP frame length check: OK - 140 bytes]
```

# Které pakety jsou zde přenášeny?

```
Internet Protocol Version 4, Src: 192.168.16.23 (192.168.16.23), Dst: 192.168.16.24
User Datagram Protocol, Src Port: murx (2743), Dst Port: igcp (2801)
Real-time Transport Control Protocol (Receiver Report)
```

```
⊕ [Stream setup by H245 (frame 597)]
  10.. .... = Version: RFC 1889 Version (2)
  ..0. .... = Padding: False
  ...0 0000 = Reception report count: 0
  Packet type: Receiver Report (201)
  Length: 1 (8 bytes)
  Sender SSRC: 0x196d27c5 (426584005)
Real-time Transport Control Protocol (Source description)
Real-time Transport Control Protocol (Goodbye)
```

```
⊕ [Stream setup by H245 (frame 597)]
  10.. .... = Version: RFC 1889 Version (2)
  ..0. .... = Padding: False
  ...0 0001 = Source count: 1
  Packet type: Goodbye (203)
  Length: 4 (20 bytes)
  Identifier: 0x196d27c5 (426584005)
  Length: 8
  Text: Teardown
```

```
[RTCP frame length check: OK - 116 bytes]
```

# O popis jakého protokolu se zde jedná?

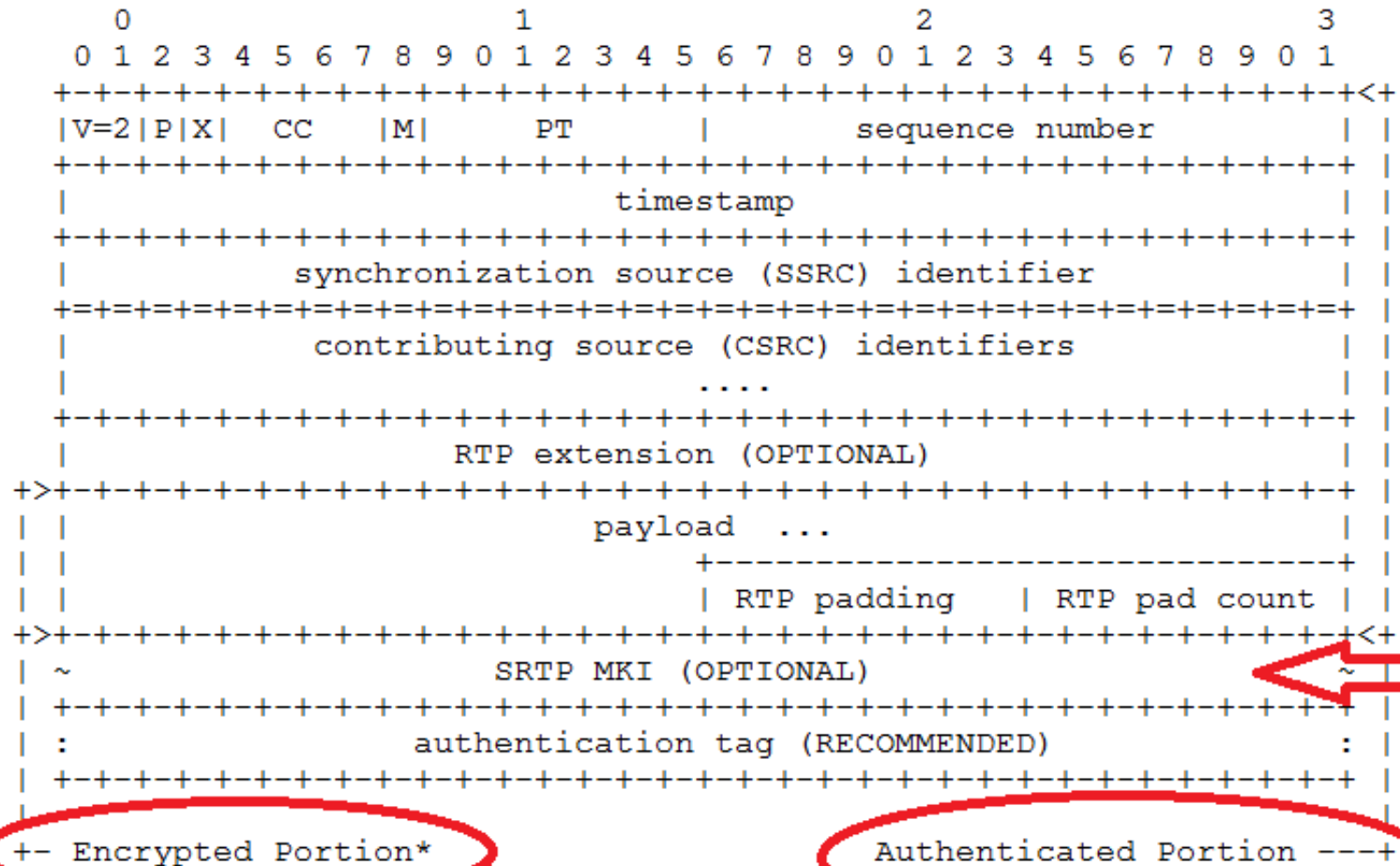



# Obsah

---

1. Skinny
2. Typy volání
3. Konfigurace Cisco IP telefonu

# The Skinny Client Control Protocol

---

## 1. Skinny

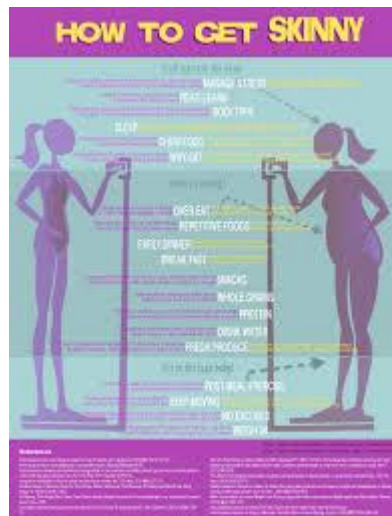

# Co je SCCP

---

- Proprietární protokol firmy Cisco, který složí ke komunikaci mezi IP telefony Cisco (obvykle 79xx) a Cisco Call Managerem (CCM). Call Manažer je proxy na bázi H.323.
- SCCP byl původně vyvinut společností Selsius Corporation. Termín „skinny“ (pohublý) vyjadřuje, že SCCP je jednoduchý a nekomplikovaný ("light") protokol a je nenáročný na práci počítače. Telefon je tupý terminál zcela řízený CCM.
- Cílem je nízká cena a složitost koncových stanic (používá TCP port 2000 anebo SSL port 2443).

# K čemu slouží CCM(E)

---

- management
- monitoring
- billing



# Funkce skinny

CCM úplně řídí IP telefony. To znamená, že když někdo na telefonu zvedne sluchátko, tak telefon oznámí CCM zvednuté sluchátko.

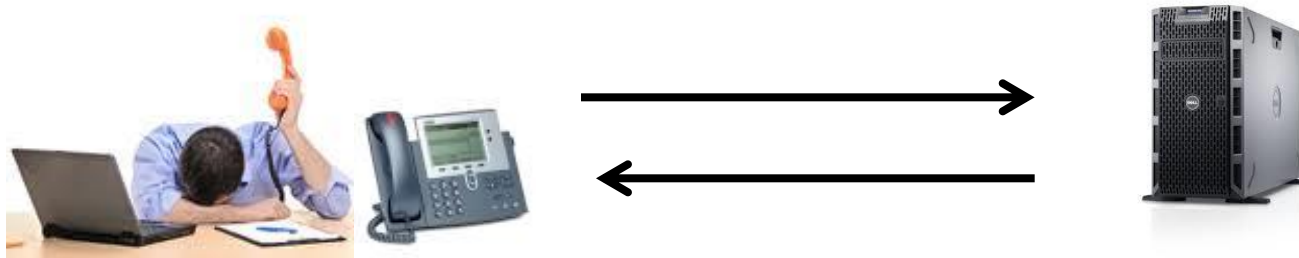

CCM mu poté řekne, ať začne přehrávat určitý tón a ať na displeji ukáže např. 123.

# Použití tohoto signalizačního protokolu

---

- registrace koncových bodů
- posílání zpráv (zvednuto/položeno sluchátko)
- adresace (vytáčení čísel)
- zobrazování na displeji atd.

Jde o proprietární protokol => problémy s dokumentací

# Skinny topologie

U CCME je směrovač konfigurován nejen jako call server, ale i jako DHCP server

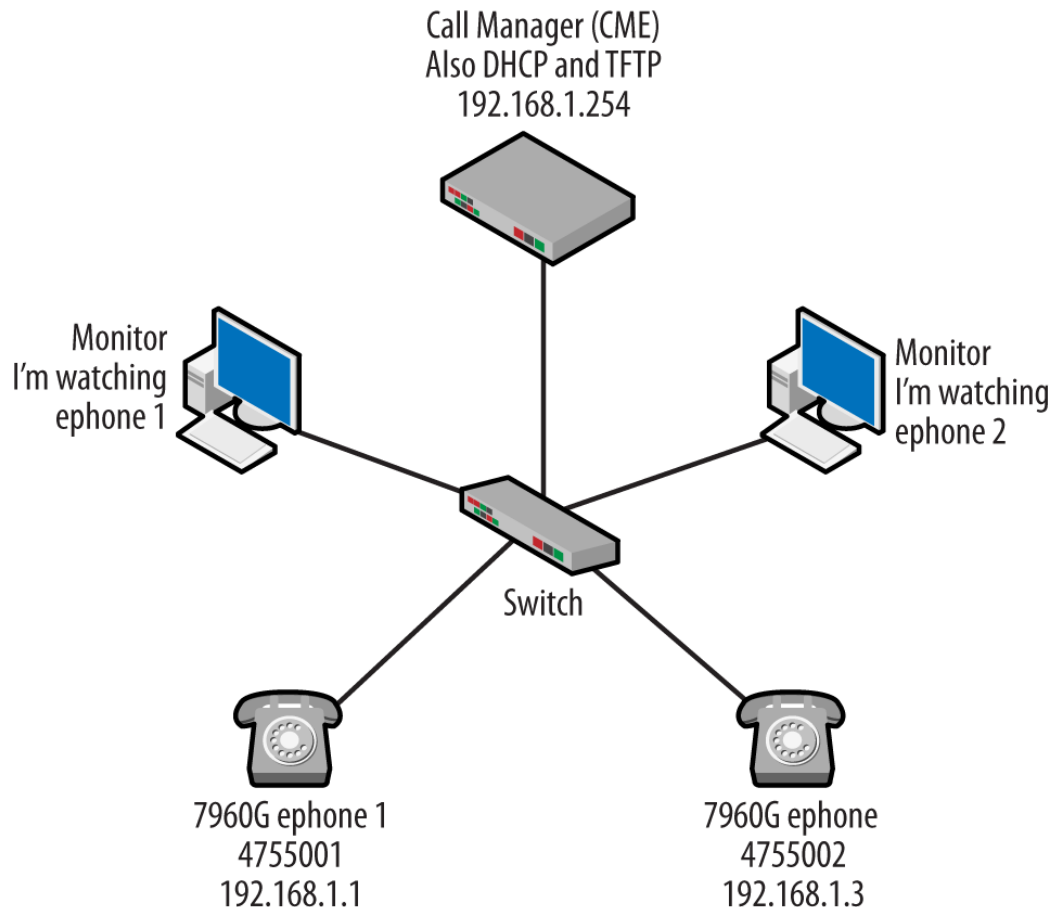

# Stážení souborů pomocí TFTP

---

TFTP	Read Request, File: CTLSEP0013C4615F16.tlv, Transfer type: octet
TFTP	Read Request, File: SEP0013C4615F16.cnf.xml, Transfer type: octet
TFTP	Read Request, File: CTLSEP0013C4615F16.tlv, Transfer type: octet
TFTP	Read Request, File: SEP0013C4615F16.cnf.xml, Transfer type: octet
TFTP	Read Request, File: English_United_States/7960-font.xml, Transfer type: octet
TFTP	Read Request, File: English_United_States/SCCP-dictionary.xml, Transfer type: octet
TFTP	Read Request, File: English_United_States/7960-dictionary.xml, Transfer type: octet
TFTP	Read Request, File: English_United_States/7960-kate.xml, Transfer type: octet
TFTP	Read Request, File: United_States/7960-tones.xml, Transfer type: octet
TFTP	Read Request, File: SEP0013C4615F16.cnf.xml, Transfer type: octet
TFTP	Read Request, File: RINGLIST.XML, Transfer type: octet
TFTP	Read Request, File: DISTINCTIVERINGLIST.XML, Transfer type: octet

# Příprava konfigurace CUCM Express

---

```
R1# archive tar /xtract tftp://10.0.0.10/cme-basic-7.1.0.1.tar flash:
Loading cme-basic-7.1.0.1.tar from 10.0.0.10 (via FastEthernet0/0): !
extracting APPS-1.2.1.SBN (2593969 bytes)!!!!!!!!!!!!!!
extracting apps11.8-4-1-23.sbn (2925555 bytes)!!!!!!!!!!!!!!
R1(config)# ip http server
R1(config)# ip http authentication local
R1(config)# username firewall privilege 15 secret mysecret
R1(config)# file privilege 0
R1# configure terminal
Enter configuration commands, one per line. End with CNTL/Z.
R1(config)# telephony-service
R1(config-telephony)# web admin system secret 0 mysecret
```

# CME každé pro svůj IOS

Cisco IOS Release	Cisco Unified CME Version	Cisco Unified CME GUI Version	Specifications Link
15.2(2)T	9.0	9.0.0.0	<a href="#">CME 9.0 Link</a>
15.1(4)T	8.6	8.6.0.0	<a href="#">CME 8.6 Link</a>
15.1(3)T	8.5	8.5.0.0	<a href="#">CME 8.5 Link</a>
15.1(2)T	8.1	8.1.0.0	<a href="#">CME 8.1 Link</a>
15.1(1)T	8.0	8.0.0.0	<a href="#">CME 8.0 Link</a>
15.0(1) XA	8.0	8.0.0.0	<a href="#">CME 8.0 Link</a>
15.0(1) M	7.1	7.1.1.0	<a href="#">CME 7.1 Link</a>
12.4(24)T	7.1	7.1.0.0	<a href="#">CME 7.1 Link</a>
12.4(22)T	7.0(1)	7.0.0.1	<a href="#">CME 7.0 Link</a>
12.4(20)T	7.0	7.0.0.0	<a href="#">CME 7.0 Link</a>
12.4(15)XZ	4.3	4.3.0.0	<a href="#">CME 4.3 Link</a>
12.4(11)XW9	4.2	4.2.0.4	<a href="#">CME 4.2 Link</a>
12.4(15)T	4.1	4.1.0.2	<a href="#">CME 4.1 Link</a>
12.4(11)T	4.0(2)	4.0.3.1	<a href="#">CME 4.0(2) Link</a>
12.4(9)T	4.0(0)	4.0.0.1	<a href="#">CME 4.0 Link</a>
12.4(6)T	3.4	3.4.0.1	<a href="#">CME 3.4 Link</a>

# Version Compatibility Matrix

## 2018

Cisco IOS Release <sup>1</sup>		Unified CME			Unified SRST	
T-Train	S-Train	Unified CME Version	Unified CME GUI Version <sup>2</sup>	Unified CME Version Specification Link <sup>3</sup>	Unified SRST Version	Unified SRST Version Specification Link <sup>3</sup>
Not Applicable	16.7.1	12.1 (No New Features Added)	12.1.0.0	Unified CME 12.1 Specifications	12.1 (Recommended Version)	Unified SRST 12.1 Specifications
15.7(3)M <sup>4</sup>	16.6.1	12.0	12.0.0.0	Unified CME 12.0 Specifications	12.0	Unified SRST 12.0 Specifications
Not Applicable	16.5.1b	11.7	11.7.0.0	Unified CME 11.7 Specifications	11.7 (No New Features Added)	Unified SRST 11.7 Specifications
15.6(3)M1	16.4.1	11.6	11.6.0.0	Unified CME 11.6 Specifications	11.6 (No New Features Added)	Unified SRST 11.6 Specifications
15.6(3)M	16.3.1	11.5	11.5.0.0	Unified CME 11.5 Specifications	11.5 (No New Features Added)	Unified SRST 11.5 Specifications
15.6(1)T	3.17S	11.0	11.0.0.0	Unified CME 11.0 Specifications	11.0	Unified SRST 11.0 Specifications
15.4(3)M	15.4(3)S	10.5	10.5.0.0	Unified CME 10.5 Specifications	10.5	Unified SRST 10.5 Specifications
15.3(3)M		10.0	10.0.0.0	Unified CME 10.0 Specifications	10.0	Unified SRST 10.0 Specifications
15.3(2)T		9.5	9.5.0.0	Unified CME 9.5 Specifications	9.5	Unified SRST 9.5 Specifications
15.2(4)M		9.1	9.1.0.0	Unified CME 9.1 Specifications	9.1	Unified SRST 9.1 Specifications
15.2(2)T		9.0	9.0.0.0	Unified CME 9.0 Specifications	9.0	Unified SRST 9.0 Specifications
15.2(1)T		8.8	8.8.0.0	Unified CME 8.8 Specifications	8.8	Unified SRST 8.8 Specifications
15.1(4)M		8.6	8.6.0.0	Unified CME 8.6 Specifications	8.6	Unified SRST 8.6 Specifications

# Domovská stránka CUCM express

Cisco Unified Communications...

 **Cisco Unified Communications Manager Express**  
> Powered by Cisco IOS®

[Home](#) | [Logout](#)

Configure ▾ Voice Mail ▾ Administration ▾ Reports ▾ Help ▾

Cisco Unified CME System Administration  
Cisco Systems 1998 - 2007. All rights reserved.

Done



# Configure > System Parameters

The screenshot displays the Cisco Unified Communications Manager Express configuration page. The browser title is "Cisco Unified Communications...". The page header includes the Cisco logo and the text "Cisco Unified Communications Manager Express" and "Powered by Cisco IOS". A navigation bar contains links for "Home" and "Logout". Below this is a menu with "Configure", "Voice Mail", "Administration", "Reports", and "Help". The main content area is titled "Configure > System Parameters". On the left, a sidebar lists various configuration options, with "Administrator's Login Account" selected and highlighted. The main content area shows the configuration for the "Administrator's Login Account" with the following fields:

- Admin User Name : admin
- Admin User Type : System (dropdown menu)
- New Password : (empty text box)
- Confirm Password : (empty text box)
- Delete Customer Admin :

A "Change" button is located at the bottom of the configuration area.

# Asociac directory number (DN) s MAC adresou

---

```
ephone-dn 1 dual-line
```

```
number 737215217
```

```
ephone 1
```

```
mac-address 0013.C461.5F16
```

```
button 1:1
```

(tlačítko: dual line)

# Popis základních systémových parametrů

---

- **Administrator's Login Account** – účet CCME GUI.
- **Date and Time Format** – datum a čas zobrazující se na IP telefonech.
- **IP Phone URLs** – URLs IP telefonů na XML služby.
- **Max. Number of IP Phones**
- **System Message** – zpráva, která se zobrazí na IP telefonech.
- **System Time** – Umožňuje nastavení roku, month, dne a času. Jinak time-wedit pod Telephony-service.
- **Timeout** – doby čekání na tel číslo, zvednutí sluchátka a na čekání při obsazení.
- **Transfer Patterns** – překlady čísel, např. přepnutí na mobil.
- **MOH File** – soubor Music-On-Hold (8Khz, mono, 8bit, ve formátu .wav A/mu-Law.

# Co chybí zadat?

```
Sitel_R(config)#telephony-service
Sitel_R(config-telephony)#?
  auto          Define dn range for auto assignment
  auto-reg-ephone  Enable Ephone Auto-Registration
  create        create cnf for ethernet phone
  exit          Exit from telephony config mode
  ip            Define IP address and port for Telephony
  keepalive     Define keepalive timeout period to
  max-dn        Maximum directory numbers supported
  max-ephones   Define max number of IP phones
  no            Negate or set default values of a
Sitel_R(config-telephony)#max-eph
Sitel_R(config-telephony)#max-ephones ?
  <1-42> Maximum phones to support
Sitel_R(config-telephony)#max-ephones 3
Sitel_R(config-telephony)#max-dn 3
Sitel_R(config-telephony)#ip ?
  source-address Define IP address and port for Telephony
Sitel_R(config-telephony)#ip sour
Sitel_R(config-telephony)#ip source address 10.0.0.1
```

# Chybělo zadat číslo portu 2000

```
Sitel_R(config-telephony)#max-eph
Sitel_R(config-telephony)#max-ephones ?
  <1-42> Maximum phones to support
Sitel_R(config-telephony)#max-ephones 3
Sitel_R(config-telephony)#max-dn 3
Sitel_R(config-telephony)#ip ?
  source-address Define IP address and port for Telephony-Service/Fallback
Sitel_R(config-telephony)#ip sour
Sitel_R(config-telephony)#ip source-address 10.0.0.1
% Incomplete command.
Sitel_R(config-telephony)#ip source-address 10.0.0.1 ?
  port Define tcp port for Telephony Service/CM FALLBACK
Sitel_R(config-telephony)#ip source-address 10.0.0.1 port ?
  <2000-9999> Specify the port: 2000 - 9999
Sitel_R(config-telephony)#ip source-address 10.0.0.1 port 2000
```

# Kontrola parametrů ephounů

---

```
Site1_R(config-telephony)#do sh ephone  
  
ephone-1 Mac:0030.A330.4261 TCP socket:[1] activeLine:1 UNREGISTERED  
mediaActive:0 offhook:1 ringing:0 reset:0 reset_sent:0 paging 0 debug:0 caps:8  
IP:0.0.0.0 0    keepalive 43 max_line 2  
button 1: dn CH1 DOWN
```

# Kontrola konfigurace CUCME

---

```
telephony-service
  max-ephones 3
  max-dn 3
  ip source-address 10.0.0.1 port 2000
!
ephone 1
  device-security-mode none
  mac-address 0030.A330.4261
!
ephone 2
  device-security-mode none
  mac-address 0060.47BC.303C
!
```

# Nastavení čísla (dn) prvního telefonu

```
Sitel_R(config-telephony)#ephone-dn 1
Sitel_R(config-ephone-dn)#%LINK-3-UPDOWN: Interface ephone_dsp DN 1.1, changed s
tate to up

Sitel_R(config-ephone-dn)#
Sitel_R(config-ephone-dn)#
Sitel_R(config-ephone-dn)#?
  exit      Exit from ephone dn configuration mode
  no        Negate or set default values of a command
  number    Define E.164 telephone number
Sitel_R(config-ephone-dn)#number 1000
Sitel_R(config-ephone-dn)#ephone-dn 2
```



# Nastavení čísla (dn) druhého telefonu

---

```
Site1_R(config-ephone-dn)#ephone-dn 2  
Site1_R(config-ephone-dn)#%LINK-3-UPDOWN: Interface ephone_dsp DN 2.1, changed s  
tate to up  
number 2000
```

# Registrace prvního telefonu

```
Sitel_R(config-ephone-dn)#ephone 1
Sitel_R(config-ephone)#?
  button      Assign ephone-dn phone lines to phone using format with feature
              options.
  exit        Exit from ephone configuration mode
  mac-address define ethernet phone MAC address
  no          Negate or set default values of a command
  type        Define ip-phone type
Sitel_R(config-ephone)#button ?
  LINE button-index:dn-index pairs example 1:2 2:5 Configuration line:button
      with separator feature options: normal phone lines      example      button
      1:2 2:5
Sitel_R(config-ephone)#button 1:1
Sitel_R(config-ephone)#type ?
  7960        Cisco IP Phone 7960
  CIPC        Cisco IP Phone CIPC
  ata         ATA phone emulation for analog phone
Sitel_R(config-ephone)#type
%IPPHONE-6-REGISTER: ephone-1 IP:172.16.0.3 Socket:2 DeviceType:Phone has regist
ered.
7960
Sitel_R(config-ephone)#
```

# Registrace druhého telefonu

---

```
Site1_R(config-ephone)#ephone 2
Site1_R(config-ephone)#button 1:2
Site1_R(config-ephone)#type 7960
Site1_R(config-ephone)#
%IPPHONE-6-REGISTER: ephone-2 IP:172.16.0.2 Socket:2 DeviceType:Phone has regist
ered.
```

# Parametry zvukového souboru

---

Index vyzváněcích tónů se nachází v souboru Ringlist.xml, který je uložen v Rootu TFTP serveru. Může obsahovat až 50 vyzváněcích tónů o parametrech:

- formát Raw PCM (bez záhlaví)
- 8000 vzorků za sekundu
- 8 bitů na vzorek
- uLaw komprese
- velikost min 240 vzorků
- max. 16 080 vzorků

# Fungování Skinny

---

1. VoIP telefony přijmou adresy od DHCP serveru (router).
2. VoIP telefony kontaktují TFTP server pro aktualizované soubory.
3. Telefony se zaregistrují u Call Serveru.
4. Volající telefon kontaktuje Call Server s číslem cíle.
5. Call Server kontaktuje cílový telefon.
6. Call Server předává parametry volání oběma telefonům.
7. Telefony spolu komunikují přímo.
8. Jeden z telefonů ukončí hovor.
9. Call server zruší operaci.

# Úvodní handshaking

---

Transportním protokolem je TCP

```
TCP    50752 > cisco-sccp [SYN] Seq=0 win=1400 Len=0 MSS=1400
TCP    cisco-sccp > 50752 [SYN, ACK] Seq=0 Ack=1 win=4128 Len=0 MSS=1400
TCP    50752 > cisco-sccp [ACK] Seq=1 Ack=1 win=1400 Len=0
```

# Formát skinny zpráv

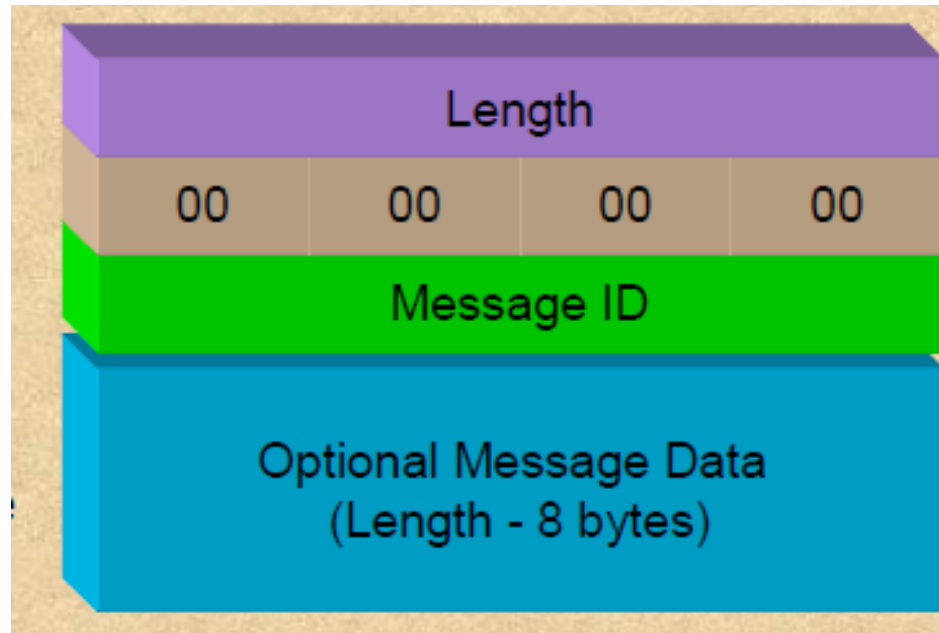

- v jednom paketu může být i více zpráv
- plýtvá se prostorem☹
- Pole o 4 byte, aby se to dobře v PC zpracovávalo

# Vybrané zprávy skinny

SCCP

## SCCP (“Skinny”) Messages

(in order of appearance)

### Stage I – Phone/CallMgr registration

	Msg	Usage	Data
→	0001	RegisterMessage	Device Name, Station UserID & Instance, IP Address, Device Type, Max Streams
→	0002	IPPortMessage	IP and Port Terminal is listening on
←	0081	RegisterAckMessage	Keep Alive Interval, Date Template (M/D/YA), Secondary Keep Alive Interval
←	009B	CapabilitiesRequest	Call Mgr asks for Station capabilities
→	0010	CapabilitiesResponse	CapCount capabilities(PayLoad/MaxFramesPerPacket)
→	000F	VersionRequest	Station requests Call Mgr version
←	0098	VersionResponse	Call Mgr Version
→	000E	ButtonTemplateRequest	--
←	0097	ButtonTemplateMessage	Button offset/count and 40-something button defs
→	000D	TimeDateRequest	--
←	0094	DefineTimeDate	Y/M/WD/D, Hour/Min/Sec/mSec, 32-bit TimeStamp

→: Phone to Call Mgr ←: Call Mgr to phone



# Zprávy Skinny

Filter: `skinny && ip.src==192.168.1.1` Expression... Clear Apply

No.	Source	Destination	Protocol	Info
217	192.168.1.1	192.168.1.254	SKINNY	AlarmMessage
218	192.168.1.1	192.168.1.254	SKINNY	AlarmMessage
219	192.168.1.1	192.168.1.254	SKINNY	RegisterMessage
224	192.168.1.1	192.168.1.254	SKINNY	HeadsetStatusMessage
226	192.168.1.1	192.168.1.254	SKINNY	CapabilitiesResMessage
227	192.168.1.1	192.168.1.254	SKINNY	HeadsetStatusMessage
228	192.168.1.1	192.168.1.254	SKINNY	ButtonTemplateReqMessage
231	192.168.1.1	192.168.1.254	SKINNY	SoftKeyTemplateReqMessage
234	192.168.1.1	192.168.1.254	SKINNY	SoftKeySetReqMessage
243	192.168.1.1	192.168.1.254	SKINNY	LineStatReqMessage
248	192.168.1.1	192.168.1.254	SKINNY	LineStatReqMessage
251	192.168.1.1	192.168.1.254	SKINNY	LineStatReqMessage
255	192.168.1.1	192.168.1.254	SKINNY	LineStatReqMessage
259	192.168.1.1	192.168.1.254	SKINNY	LineStatReqMessage
264	192.168.1.1	192.168.1.254	SKINNY	LineStatReqMessage
272	192.168.1.1	192.168.1.254	SKINNY	RegisterAvailableLinesMessage
274	192.168.1.1	192.168.1.254	SKINNY	TimeDateReqMessage
291	192.168.1.1	192.168.1.254	SKINNY	KeepAliveMessage

# Registrace telefonu k CCM (typ, jméno)

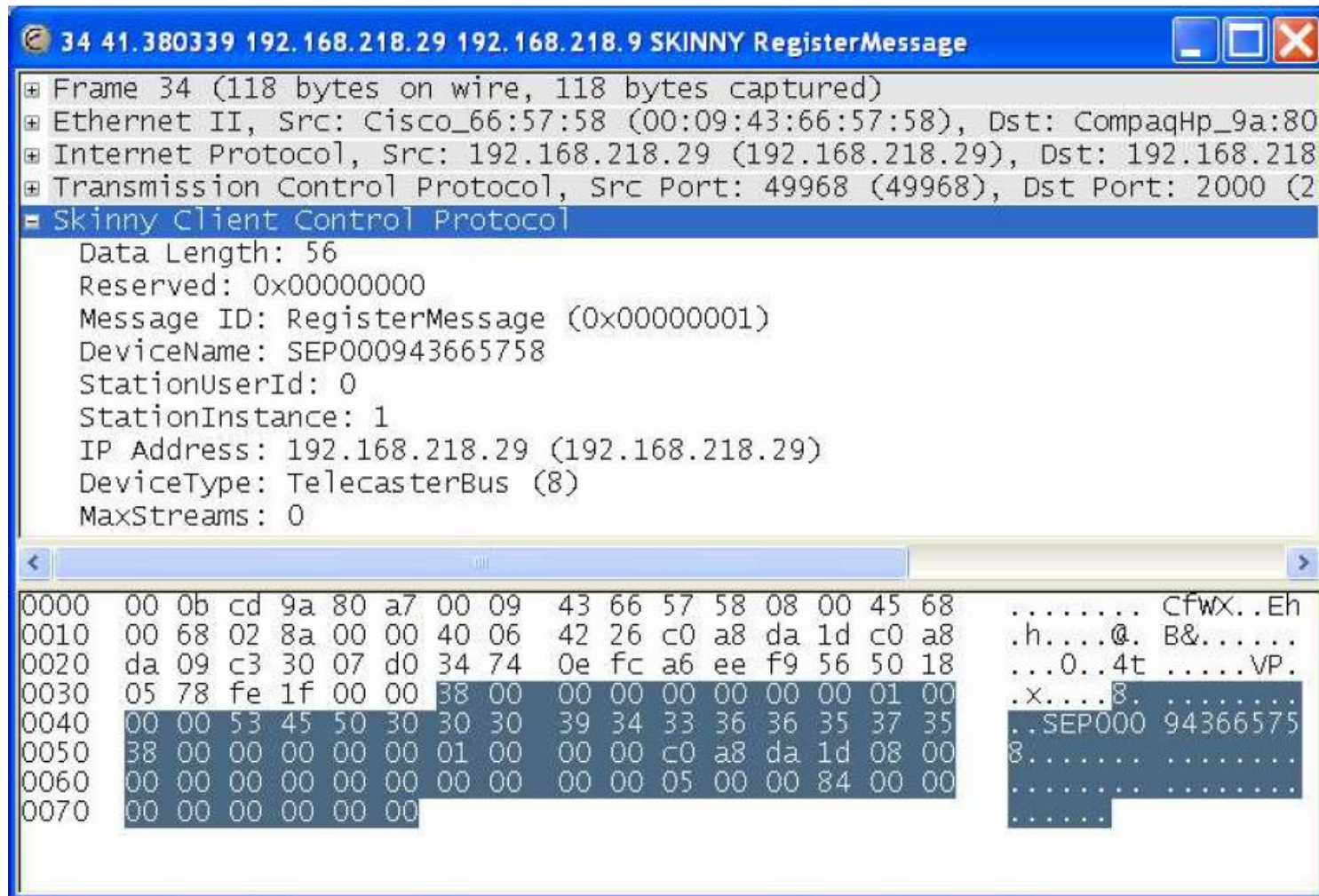

The image shows a Wireshark packet capture window titled "34 41.380339 192.168.218.29 192.168.218.9 SKINNY RegisterMessage". The packet list pane shows a single packet of type "Skinny Client Control Protocol". The packet details pane shows the following fields:

- Data Length: 56
- Reserved: 0x00000000
- Message ID: RegisterMessage (0x00000001)
- DeviceName: SEP000943665758
- StationUserId: 0
- StationInstance: 1
- IP Address: 192.168.218.29 (192.168.218.29)
- DeviceType: TelecasterBus (8)
- MaxStreams: 0

The packet bytes pane shows the raw data in hexadecimal and ASCII. The ASCII column contains the following text:

```
..... CfWX..Eh
.h....@. B&.....
...0..4t .....VP.
.x....8. ....
..SEP000 94366575
8.....
.....
```

# Skinny registrace na port 2000

```
Ethernet II, Src: Cisco_61:5f:16 (00:13:c4:61:5f:16), Dst: Cisco_f4:c2:10 (00:1c:58:f4:c2:10)
Internet Protocol Version 4, Src: 192.168.1.1 (192.168.1.1), Dst: 192.168.1.254 (192.168.1.254)
Transmission Control Protocol, Src Port: 50752 (50752), Dst Port: cisco-sccp (2000), Seq: 209,
Skinny Client Control Protocol
  Data length: 56
  Header version: Basic (0x00000000)
  Message ID: RegisterMessage (0x00000001)
  Device name: SEP0013C4615F16 ———— MAC adresa
  Station user ID: 0
  Station instance: 1
  IP address: 192.168.1.1 (192.168.1.1)
  Device type: TelecasterMgr (7)
  Max streams: 0
```

# Potvrzení registrace

```
Internet Protocol Version 4, Src: 192.168.1.254 (192.168.1.254), Dst: 192.168.1.1 (192.168.1.1)
Transmission Control Protocol, Src Port: cisco-sccp (2000), Dst Port: 50752 (50752), Seq: 1, Ack: 273
Skinny Client Control Protocol
  Data length: 24
  Header version: Basic (0x00000000)
  Message ID: RegisterAckMessage (0x00000081)
  Keep-alive interval: 30
  Date template: M/D/YA
  Secondary keep-alive interval: 60
```

Ověření, zda je telefon aktivní

# CCM se pak ptá, co telefon umí

The screenshot shows a network packet capture window titled "38 41. 386894 192.168.218.29 192.168.218.9 SKINNY CapabilitiesResMessage". The packet is identified as "Frame 58 (182 bytes on wire, 182 bytes captured)". The protocol stack is shown as Ethernet II, Internet Protocol, Transmission Control Protocol, and Skinny Client Control Protocol. The Skinny Client Control Protocol details are as follows:

- Data Length: 120
- Reserved: 0x00000000
- Message ID: CapabilitiesResMessage (0x00000010)
- CapCount: 7
- PayloadCapability: Wideband 256k (25)
- MaxFramesPerPacket: 120
- PayloadCapability: G.711 u-law 64k (4)
- MaxFramesPerPacket: 40
- PayloadCapability: G.711 A-law 64k (2)
- MaxFramesPerPacket: 40
- PayloadCapability: G.729 Annex B (15)
- MaxFramesPerPacket: 60
- PayloadCapability: G.729 Annex A+Annex B (16)
- MaxFramesPerPacket: 60
- PayloadCapability: G.729 (11)
- MaxFramesPerPacket: 60
- PayloadCapability: G.729 Annex A (12)
- MaxFramesPerPacket: 60

The bottom of the window shows a hex dump of the packet data, with the first few lines visible:

```
0000 00 0b cd 9a 80 a7 00 09 43 66 57 58 08 00 45 68 ..... CfwX..Eh
0010 00 a8 02 8c 00 00 40 06 41 e4 c0 a8 da 1d c0 a8 .....@. A.....
0020 da 09 c3 30 07 d0 34 74 0f 4c a6 ee f9 82 50 18 ...0..4t .L...P.
0030 05 78 29 27 00 00 78 00 00 00 00 00 00 00 10 00 .x)'...x.....
0040 00 00 07 00 00 00 19 00 00 00 78 00 00 00 00 00 .....x.....
0050 00 00 00 00 00 00 04 00 00 00 28 00 00 00 00 00 .....(.....
0060 00 00 00 00 00 00 02 00 00 00 28 00 00 00 00 00 .....(.....
0070 00 00 00 00 00 00 0f 00 00 00 3c 00 00 00 00 00 .....<.....
0080 00 00 00 00 00 00 10 00 00 00 3c 00 00 00 00 00 .....<.....
0090 00 00 00 00 00 00 0b 00 00 00 3c 00 00 00 00 00 .....<.....
00a0 00 00 00 00 00 00 0c 00 00 00 3c 00 00 00 00 00 .....<.....
00b0 00 00 00 00 00 00
```

# Výměna informací o podporovaných vlastnostech

No.	Source	Destination	Protocol	Info
222	192.168.1.254	192.168.1.1	SKINNY	CapabilitiesReqMessage
226	192.168.1.1	192.168.1.254	SKINNY	CapabilitiesResMessage

⊕ Frame 222: 66 bytes on wire (528 bits), 66 bytes captured (528 bits)

⊕ Ethernet II, Src: Cisco\_f4:c2:10 (00:1c:58:f4:c2:10), Dst: Cisco\_61:5f:16 (00:13:c4:61:5f:16)

⊕ Internet Protocol Version 4, Src: 192.168.1.254 (192.168.1.254), Dst: 192.168.1.1 (192.168.1.1)

⊕ Transmission Control Protocol, Src Port: cisco-sccp (2000), Dst Port: 50752 (50752), Seq: 33, Ack: 273

⊖ Skinny Client Control Protocol

- Data length: 4
- Header version: Basic (0x00000000)
- Message ID: CapabilitiesReqMessage (0x0000009b)

⊕ Frame 226: 182 bytes on wire (1456 bits), 182 bytes captured (1456 bits)

⊕ Ethernet II, Src: Cisco\_61:5f:16 (00:13:c4:61:5f:16), Dst: Cisco\_f4:c2:10 (00:1c:58:f4:c2:10)

⊕ Internet Protocol Version 4, Src: 192.168.1.1 (192.168.1.1), Dst: 192.168.1.254 (192.168.1.254)

⊕ Transmission Control Protocol, Src Port: 50752 (50752), Dst Port: cisco-sccp (2000), Seq: 289, Ack: 45

⊖ Skinny Client Control Protocol

- Data length: 120
- Header version: Basic (0x00000000)
- Message ID: CapabilitiesResMessage (0x00000010)
- Capabilities count: 7
- Payload capability: Wideband 256k (25)
- Max frames per packet: 120
- Payload capability: G.711 u-law 64k (4)
- Max frames per packet: 40
- Payload capability: G.711 A-law 64k (2)
- Max frames per packet: 40
- Payload capability: G.729 Annex B (15)
- Max frames per packet: 60
- Payload capability: G.729 Annex A+Annex B (16)
- Max frames per packet: 60
- Payload capability: G.729 (11)
- Max frames per packet: 60
- Payload capability: G.729 Annex A (12)
- Max frames per packet: 60

# CCM pošle zprávu o tom, kam umístit číslo

---

```
| Skinny Client Control Protocol  
  Data length: 116  
  Header version: Basic (0x00000000)  
  Message ID: LineStatMessage (0x00000092)  
  Line number: 1  
  Line directory number: 4755001  
  Fully qualified display name: 4755001  
  Display name:
```

# A jaký prompt se bude zobrazovat

---

## Skinný Client Control Protocol

Data length: 48

Header version: Basic (0x00000000)

Message ID: DisplayPromptStatusMessage (0x00000112)

Message time-out: 0

Display message: Packets!

Line instance: 0

Call identifier: 0



# Oznámení o ukončení registrace

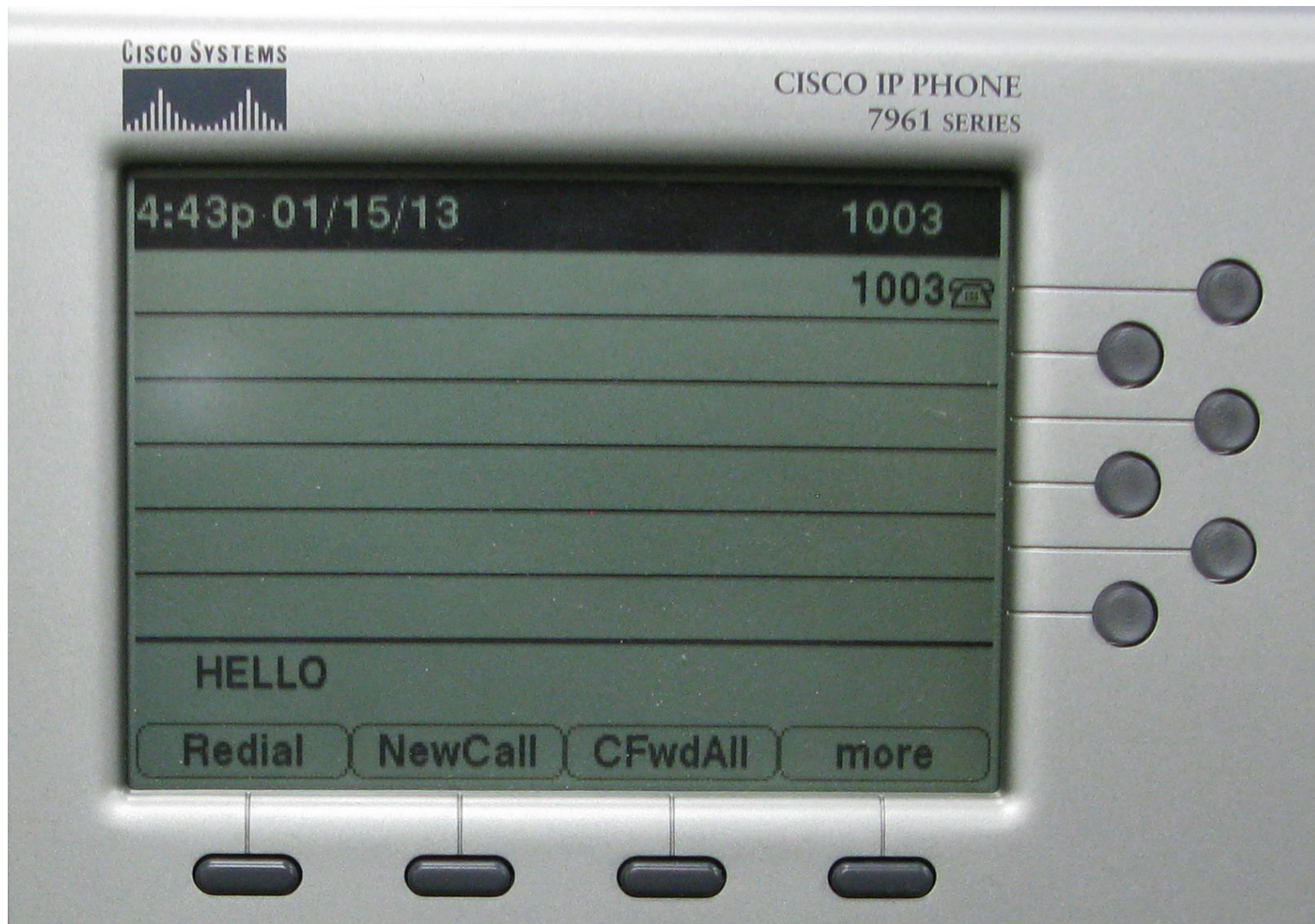

# Chci se o registraci dozvědět více

---

```
Router#show ephone registered
```

```
ephone-1 Mac:0013.C461.5F16 TCP socket:[2] activeLine:0 REGISTERED in SCCP ver 6 and Server in ver 5  
mediaActive:0 offhook:0 ringing:0 reset:0 reset_sent:0 paging 0 debug:0  
IP:192.168.1.1 50201 Telecaster 7960 keepalive 2781 max_line 6  
button 1: dn 1 number 4755001 CH1 IDLE CH2 IDLE
```



port



typ koncového bodu

# Telefon se zprávou LineStat dozví, kde je umístěno jeho dial number

```
Skinný Client Control Protocol
Data length: 116
Header version: Basic (0x00000000)
Message ID: LineStatMessage (0x00000092)
Line number: 1
Line directory number: 4755001
Fully qualified display name: 4755001
Display name:
```

Pak je mu poslán prompt

```
Skinný Client Control Protocol
Data length: 48
Header version: Basic (0x00000000)
Message ID: DisplayPromptStatusMessage (0x00000112)
Message time-out: 0
Display message: Packets!
Line instance: 0
Call identifier: 0
```

# Před a po zvednutí sluchátka

---

- Telefon periodicky odesílá „keepalive“ zprávy CCM (podle pokynů CCM během registrace).
- Když uživatel zvedne sluchátko, telefon odešle zprávu "vyvěšení" na CCM. CCM zase řekne telefon přesně, co mají dělat – od vysvětlení ON / OFF, přes prompt, přes nastavení klíče až dokonce po oznamovací tón.
- V případě chyby jsou zasílány Alarmy – většinou chyby v síti, jako např. telefon není schopen načíst soubor z TFTP, atd.  
Viz další slide

# Pak mohou chodit army

---

## Skinny Client Control Protocol

Data length: 96

Header version: Basic (0x00000000)

Message ID: AlarmMessage (0x00000020)

Alarm severity: Warning (1)

Display message: 3: Name=SEP0013C4615F16 Load=7.2(2.0)Version Error

Alarm param 1: 0x00000900

Alarm param 2: 192.168.1.1 (192.168.1.1)

# Vybrané zprávy skinny

SCCP

## SCCP (“Skinny”) Messages

(in order of appearance)

### Stage I ½ – Keep Alive/Alarm Messages

	Msg	Usage	Data
→	0000	KeepAliveMessage	-- (sent periodically by phone)
←	0100	KeepAliveAckMessage	-- (sent periodically by callMgr)
→	0020	Alarm Message	Alarm Severity, Display Message & Params

### Stage II – Picking up the handset

	Msg	Usage	Data
→	0006	OffHookMessage	--
←	0099	DisplayTextMessage	ASCII text, NULL terminated
←	0086	SetLampMessage	Stimulus, StimulusInstance, LampMode
←	0111	CallStateMessage	Call State (code), Line Instance, Call Ident
←	0112	DisplayPromptStatus	Timeout, DisplayMessage*, Line Inst, Call Ident
←	0110	SelectSoftKeysMessage	Line Instance, Call Ident, SoftKeySet, SoftKeyMap (16-bit bitmap)
←	0116	ActivateCallPlaneMessage	Line Instance
←	0082	StartToneMessage	Dial Tone (as 32 bit identifier)

→: Phone to Call Mgr ←: Call Mgr to phone

# Zprávy vytáčení (dialing)

- KeyPadButton zpráva (pro každou vytočenou číslici) a zpráva CallState. Ta se zasílá CCM na stanici v různých fázích volání.
- Všimněte si, opět, že protokol je velmi nevhodný. Každá číslice je poslána samostatně v KeyPadButton zprávě (jako jeden byte ze čtyř).

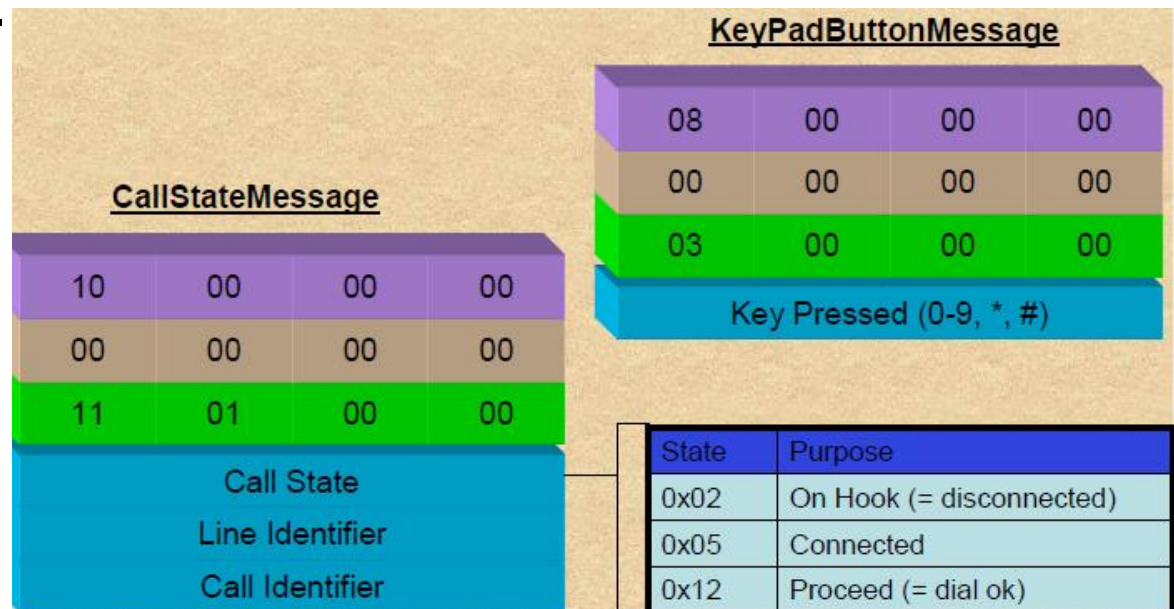

# Točíme číslo 475

---

Skippy Client Control Protocol Data length: 16 Header version: Basic Message ID: KeypadButtonMessage Keypad button: <b>Four</b> (0x00000004) Line instance: 1 Call identifier: 2	Skippy Client Control Protocol Data length: 16 Header version: Basic Message ID: KeypadButtonMessage Keypad button: <b>Seven</b> (0x00000007) Line instance: 1 Call identifier: 2	Skippy Client Control Protocol Data length: 16 Header version: Basic Message ID: KeypadButtonMessage Keypad button: <b>Five</b> (0x00000005) Line instance: 1 Call identifier: 2
--	---	--



# Call Server odpovídá zprávou DialedNumberMessage

---

```
Internet Protocol Version 4, Src: 192.168.1.254 (192.168.1.254), Dst: 192.168.1.1 (192.168.1.1)
Transmission Control Protocol, Src Port: cisco-sccp (2000), Dst Port: 50202 (50202), Seq: 225,
Skinny Client Control Protocol
  Data length: 36
  Header version: Basic (0x00000000)
  Message ID: DialedNumberMessage (0x0000011d)
  Called party number: 4755002
  Line instance: 1
  Call identifier: 13
```

# Je třeba pak vyloudit zvuk „zvonění“

---

## Skinny Client Control Protocol

Data length: 20

Header version: Basic (0x00000000)

Message ID: StartToneMessage (0x00000082)

Tone: AlertingTone (0x00000024)

Line instance: 1

Call identifier: 2

# Na příjem je předáno číslo volajícího a zobrazen prompt

```
Internet Protocol Version 4, Src: 192.168.1.254 (192.168.1.254), Dst: 192.168.1.3 (192.168.1.3)  
Transmission Control Protocol, Src Port: cisco-sccp (2000), Dst Port: 51052 (51052), Seq: 13, A  
Skinny Client Control Protocol
```

```
Data length: 28  
Header version: Basic (0x00000000)  
Message ID: CallStateMessage (0x00000111)  
Call state: RingIn (4)  
Line instance: 1  
Call identifier: 14
```

```
Internet Protocol Version 4, Src: 192.168.1.254 (192.168.1.254), Dst: 192.168.1.3 (192.168.1.3)  
Transmission Control Protocol, Src Port: cisco-sccp (2000), Dst Port: 51052 (51052), Seq: 49, A  
Skinny Client Control Protocol
```

```
Data length: 48  
Header version: Basic (0x00000000)  
Message ID: DisplayPromptStatusMessage (0x00000112)  
Message time-out: 0  
Display message: \200\027: 4755001  
Line instance: 1  
Call identifier: 14
```

# Další zpráva dá pokyn na zvonění na příjmu

---

```
Internet Protocol Version 4, Src: 192.168.1.254 (192.168.1.254), Dst: 192.168.1.3 (192.168.1.3)
Transmission Control Protocol, Src Port: cisco-sccp (2000), Dst Port: 51052 (51052), Seq: 581,
Skinny Client Control Protocol
  Data length: 20
  Header version: Basic (0x00000000)
  Message ID: SetRingerMessage (0x00000085)
  Ring type: InsideRing (0x00000002)
  Ring mode: RingForever (0x00000001)
  Line instance: 1
  Call identifier: 12
```

# Po zprávě o zvednutí sluchátka zvonění skončí

---

```
Internet Protocol Version 4, Src: 192.168.1.3 (192.168.1.3), Dst: 192.168.1.254 (192.168.1.254)
Transmission Control Protocol, Src Port: 51052 (51052), Dst Port: cisco-sccp (2000), Seq: 13, Ack
Skinny Client Control Protocol
  Data length: 12
  Header version: Basic (0x00000000)
  Message ID: OffHookMessage (0x00000006)
  Line instance: 1
  Call identifier: 12
```

# Pro započetí hovoru server dá příkaz k otevření kanálů na straně příjmu

```
Internet Protocol Version 4, Src: 192.168.1.254 (192.168.1.254), Dst: 192.168.1.3 (192.168.1.3)  
Transmission Control Protocol, Src Port: cisco-sccp (2000), Dst Port: 51052 (51052), Seq: 885,  
Skinny Client Control Protocol
```

```
Data length: 72  
Header version: Basic (0x00000000)  
Message ID: OpenReceiveChannel (0x00000105)  
Conference ID: 4  
Pass-thru party ID: 0  
MS/packet: 20  
Payload capability: G.711 u-law 64k (4)  
Echo-cancel type: Media_EchoCancellation_On (1)  
G723 bitrate: Media_G723BRate_6_4 (2)
```

```
Internet Protocol Version 4, Src: 192.168.1.3 (192.168.1.3), Dst: 192.168.1.254 (192.168.1.254)  
Transmission Control Protocol, Src Port: 51052 (51052), Dst Port: cisco-sccp (2000), Seq: 105,  
Skinny Client Control Protocol
```

```
Data length: 24  
Header version: Basic (0x00000000)  
Message ID: OpenReceiveChannelAck (0x00000022)  
Opened receive-channel status: orcOk (0)  
IP address: 192.168.1.3 (192.168.1.3)  
Port number: 27368  
Pass-thru party ID: 0
```

# ...call server určí finální parametry volání a ještě není konec...

```
Internet Protocol Version 4, Src: 192.168.1.254 (192.168.1.254), Dst: 192.168.1.3 (192.168.1.3)  
Transmission Control Protocol, Src Port: cisco-sccp (2000), Dst Port: 51052 (51052), Seq: 985,  
Skinny Client Control Protocol
```

Data length: 88

Header version: Basic (0x00000000)

Message ID: StartMediaTransmission (0x0000008a)

Conference ID: 4

Pass-thru party ID: 0

Remote IP address: 192.168.1.1 (192.168.1.1)

Remote port: 25438

MS/packet: 20

Payload capability: G.711 u-law 64k (4)

Precedence: 0

Silence suppression: Media\_SilenceSuppression\_Off (0x00000000)

Max frames per packet: 0

G723 bitrate: Media\_G723BRate\_6\_4 (2)

vzdálený port



kodek



# pro započítí hovoru server dá příkaz k otevření kanálů na straně volání

```
Internet Protocol Version 4, Src: 192.168.1.254 (192.168.1.254), Dst: 192.168.1.1 (192.168.1.1)  
Transmission Control Protocol, Src Port: cisco-sccp (2000), Dst Port: 50202 (50202), Seq: 1105,  
Skinny Client Control Protocol
```

```
Data length: 72  
Header version: Basic (0x00000000)  
Message ID: OpenReceiveChannel (0x00000105)  
Conference ID: 2  
Pass-thru party ID: 0  
MS/packet: 20  
Payload capability: G.711 u-law 64k (4)  
Echo-cancel type: Media_EchoCancellation_On (1)  
G723 bitrate: Media_G723BRate_6_4 (2)
```

```
Internet Protocol Version 4, Src: 192.168.1.1 (192.168.1.1), Dst: 192.168.1.254 (192.168.1.254)  
Transmission Control Protocol, Src Port: 50202 (50202), Dst Port: cisco-sccp (2000), Seq: 273,  
Skinny Client Control Protocol
```

```
Data length: 24  
Header version: Basic (0x00000000)  
Message ID: OpenReceiveChannelAck (0x00000022)  
Opened receive-channel status: orcOk (0)  
IP address: 192.168.1.1 (192.168.1.1)  
Port number: 25438  
Pass-thru party ID: 0
```



# Call server finalizuje nastavení kanálů

```
Internet Protocol Version 4, Src: 192.168.1.254 (192.168.1.254), Dst: 192.168.1.1 (192.168.1.1)
Transmission Control Protocol, Src Port: cisco-sccp (2000), Dst Port: 50202 (50202), Seq: 1205,
Skinny Client Control Protocol
  Data length: 88
  Header version: Basic (0x00000000)
  Message ID: StartMediaTransmission (0x0000008a)
  Conference ID: 2
  Pass-thru party ID: 0
  Remote IP address: 192.168.1.3 (192.168.1.3)
  Remote port: 27368 ————— vzdálený port
  MS/packet: 20
  Payload capability: G.711 u-law 64k (4)
  Precedence: 0
  Silence suppression: Media_SilenceSuppression_Off (0x00000000)
  Max frames per packet: 0
  G723 bitrate: Media_G723BRate_6_4 (2)
```

# Dál spolu komunikují telefony bez účasti call serveru

ARP pro zjištění MAC adresy

63	192.168.1.254	192.168.1.1	SKINNY	StartMediaTransmission
64	192.168.1.1	192.168.1.254	TCP	50202 > cisco-sccp [ACK] Seq=305 Ack=1301 Win=1400 Len=0
65	Cisco_61:5f:16	Broadcast	ARP	who has 192.168.1.3? Tell 192.168.1.1
66	Cisco_7f:32:97	Cisco_61:5f:16	ARP	192.168.1.3 is at 00:19:2f:7f:32:97
67	192.168.1.1	192.168.1.3	RTP	PT=ITU-T G.711 PCMU, SSRC=0x165F61CD, Seq=1093, Time=169872
68	192.168.1.1	192.168.1.3	RTP	PT=ITU-T G.711 PCMU, SSRC=0x165F61CD, Seq=1094, Time=170032
32	192.168.1.254	192.168.1.3	SKINNY	StartMediaTransmission
33	Cisco_61:5f:16	Broadcast	ARP	who has 192.168.1.3? Tell 192.168.1.1
34	Cisco_7f:32:97	Cisco_61:5f:16	ARP	192.168.1.3 is at 00:19:2f:7f:32:97
35	192.168.1.3	192.168.1.254	TCP	51052 > cisco-sccp [ACK] Seq=137 Ack=1081 Win=8076 Len=0
36	192.168.1.1	192.168.1.3	RTP	PT=ITU-T G.711 PCMU, SSRC=0x165F61CD, Seq=1093, Time=169872
37	192.168.1.1	192.168.1.3	RTP	PT=ITU-T G.711 PCMU, SSRC=0x165F61CD, Seq=1094, Time=170032

```
Ethernet II, Src: Cisco_61:5f:16 (00:13:c4:61:5f:16), Dst: Cisco_7f:32:97 (00:19:2f:7f:32:97)
Internet Protocol Version 4, Src: 192.168.1.1 (192.168.1.1), Dst: 192.168.1.3 (192.168.1.3)
User Datagram Protocol, Src Port: 25438 (25438), Dst Port: 27368 (27368)
Real-Time Transport Protocol
```

# Příklad komplexnější zprávy – Start Media Transmission

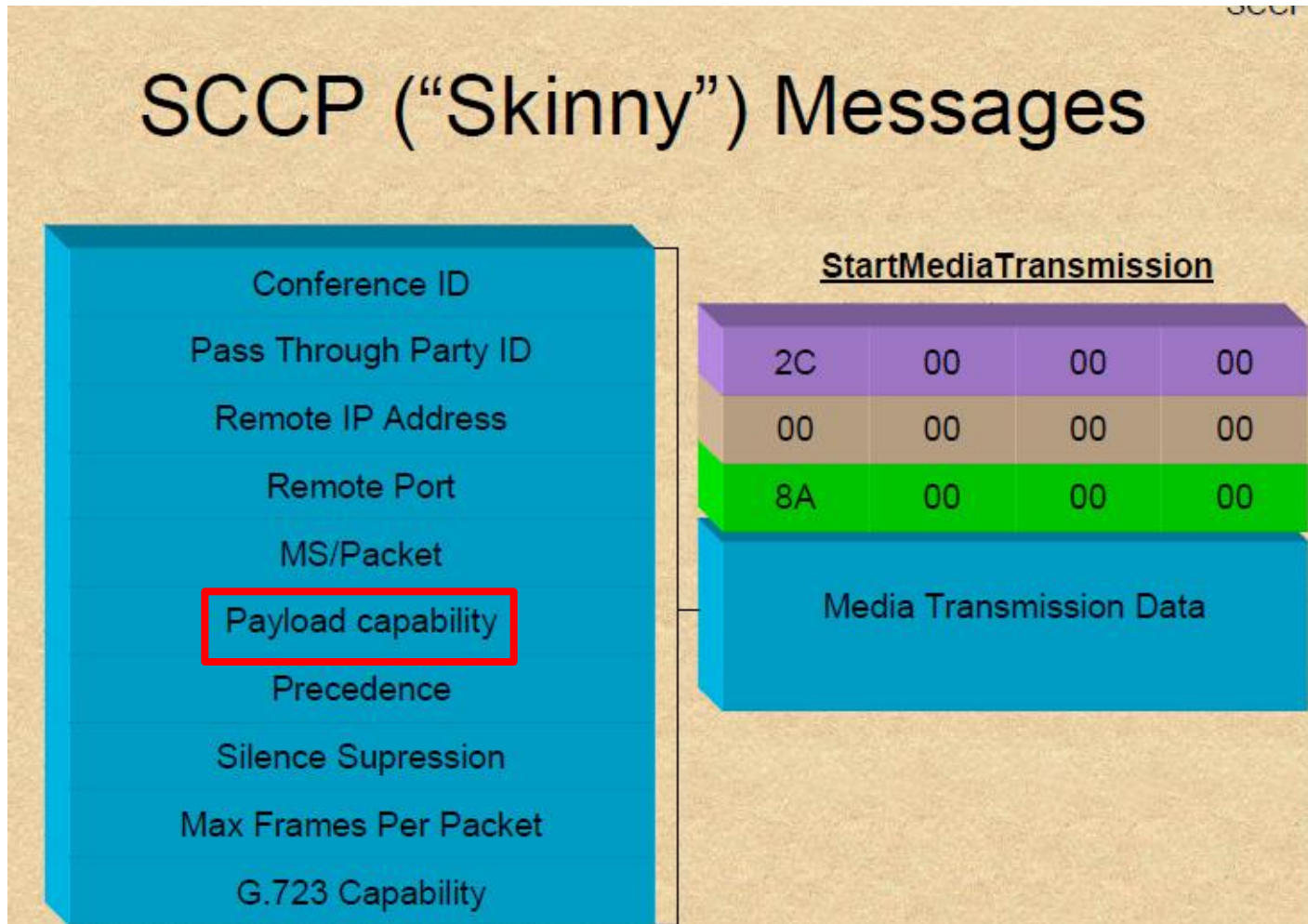



# Položení sluchátka

---

- Konec hovoru telefon signalizuje CCM zprávou "OnHook - Zavěšeno".
- CCM poté vyzve telefon, aby přestal vysílat, uzavřel kanály, nastavil stav hovoru na Zavěšeno – OnHook (odpojeny), a prezentoval defaultní uživatelský prompt.

# Vybrané zprávy skinny

SCC

## SCCP (“Skinny”) Messages

(in order of appearance)

### Stage III – Placing a call

	Msg	Usage	Data
→	0003	KeyPadButtonMessage	Dialed Digit
←	0083	StopToneMessage	0110 may follow to reconfigure softkeys..
←	008F	CallInfoMessage	Calling/Called Party & Party Names, Line Inst., Call Ident, Call Type, Orig. called party
←	0105	OpenReceiveChannel	Receive Channel Details..
←	008A	StartMediaTransmission	Transmission Channel Details..
→	0022	OpenReceiveChannelAck	Status, IP, Port, Pass Through Party ID
→	0007	OnHookMessage	-- (serves as a call hangup)
←	0113	ClearPromptStatusMess..	Line Instance, Call Ident
←	0106	CloseReceiveChannel	Conf Id, Pass Through Party Id
←	008B	StopMediaTransmission	Conf Id, Pass Through Party Id

# Položení sluchátka

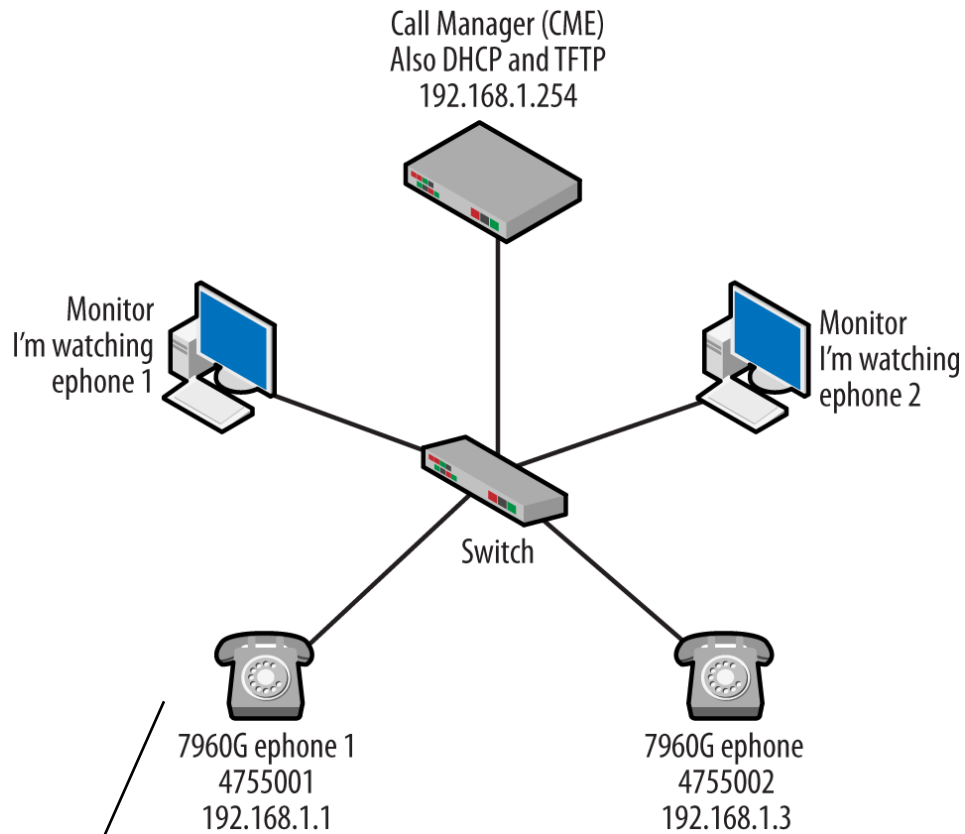

Položí sluchátko

# Byla zpráva o zvednutí sluchátka sluchátka

```
Internet Protocol Version 4, Src: 192.168.1.1 (192.168.1.1), Dst: 192.168.1.254 (192.168.1.254)  
Transmission Control Protocol, Src Port: 50202 (50202), Dst Port: cisco-sccp (2000), Seq: 13, A  
Skinny Client Control Protocol
```

```
Data length: 12  
Header version: Basic (0x00000000)  
Message ID: OffHookMessage (0x00000006)  
Line instance: 0  
Call identifier: 0
```

```
Internet Protocol Version 4, Src: 192.168.1.254 (192.168.1.254), Dst: 192.168.1.1 (192.168.1.1)  
Transmission Control Protocol, Src Port: cisco-sccp (2000), Dst Port: 50202 (50202), Seq: 13, A  
Skinny Client Control Protocol
```

```
Data length: 28  
Header version: Basic (0x00000000)  
Message ID: CallStateMessage (0x00000111)  
Call state: OffHook (1)  
Line instance: 1  
Call identifier: 13
```



# Nyní zpráva o položení sluchátka

---

```
Internet Protocol Version 4, Src: 192.168.1.3 (192.168.1.3), Dst: 192.168.1.254 (192.168.1.254)
Transmission Control Protocol, Src Port: 51052 (51052), Dst Port: cisco-sccp (2000), Seq: 209,
Skinny Client Control Protocol
  Data length: 12
  Header version: Basic (0x00000000)
  Message ID: OnHookMessage (0x00000007)
  Line instance: 0
  Call identifier: 0
```

# ...a uzavření kanálu a zastavení komunikace

```
Internet Protocol Version 4, Src: 192.168.1.254 (192.168.1.254), Dst: 192.168.1.3 (192.168.1.3)  
Transmission Control Protocol, Src Port: cisco-sccp (2000), Dst Port: 51052 (51052), Seq: 1245,  
Skinny Client Control Protocol
```

```
Data length: 16  
Header version: Basic (0x00000000)  
Message ID: CloseReceiveChannel (0x00000106)  
Conference ID: 4  
Pass-thru party ID: 0
```

```
Internet Protocol Version 4, Src: 192.168.1.254 (192.168.1.254), Dst: 192.168.1.3 (192.168.1.3)  
Transmission Control Protocol, Src Port: cisco-sccp (2000), Dst Port: 51052 (51052), Seq: 1269,  
Skinny Client Control Protocol
```

```
Data length: 16  
Header version: Basic (0x00000000)  
Message ID: StopMediaTransmission (0x0000008b)  
Conference ID: 4  
Pass-thru party ID: 0
```

# Skinny si zjišťuje statistiky bez návaznosti na RTCP – volající start

```
Internet Protocol Version 4, Src: 192.168.1.254 (192.168.1.254), Dst: 192.168.1.3 (192.168.1.3)
Transmission Control Protocol, Src Port: cisco-sccp (2000), Dst Port: 51052 (51052), Seq: 841,
Skinny Client Control Protocol
```

```
Data length: 36
Header version: Basic (0x00000000)
Message ID: ConnectionStatisticsReq (0x00000107)
Directory number: 4755002
Call identifier: 14
Stats processing type: clearStats (0)
```

```
Internet Protocol Version 4, Src: 192.168.1.3 (192.168.1.3), Dst: 192.168.1.254 (192.168.1.254)
Transmission Control Protocol, Src Port: 51052 (51052), Dst Port: cisco-sccp (2000), Seq: 33, A
Skinny Client Control Protocol
```

```
Data length: 64
Header version: Basic (0x00000000)
Message ID: ConnectionStatisticsRes (0x00000023)
Directory number: 4755002
Call identifier: 14
Stats processing type: clearStats (0)
Packets sent: 244
Octets sent: 41968
Packets Received: 250
Octets received: 43000
Packets lost: 0
Jitter: 0
Latency(ms): 13
```

# Skinny si zjišťuje statistiky bez návaznosti na RTCP – volaný start

```
Internet Protocol Version 4, Src: 192.168.1.254 (192.168.1.254), Dst: 192.168.1.1 (192.168.1.1)  
Transmission Control Protocol, Src Port: cisco-sccp (2000), Dst Port: 50202 (50202), Seq: 1697,  
Skinny Client Control Protocol
```

```
Data length: 36  
Header version: Basic (0x00000000)  
Message ID: ConnectionStatisticsReq (0x00000107)  
Directory number: 4755001  
Call identifier: 13  
Stats processing type: doNotClearStats (1)
```

```
Internet Protocol Version 4, Src: 192.168.1.1 (192.168.1.1), Dst: 192.168.1.254 (192.168.1.254)  
Transmission Control Protocol, Src Port: 50202 (50202), Dst Port: cisco-sccp (2000), Seq: 305,  
Skinny Client Control Protocol
```

```
Data length: 64  
Header version: Basic (0x00000000)  
Message ID: ConnectionStatisticsRes (0x00000023)  
Directory number: 4755001  
Call identifier: 13  
Stats processing type: doNotClearStats (1)  
Packets sent: 238  
Octets sent: 40936  
Packets Received: 229  
Octets received: 39388  
Packets lost: 0  
Jitter: 0  
Latency(ms): 0
```

# Uzavření statistik po ukončení volání

```
Internet Protocol Version 4, Src: 192.168.1.254 (192.168.1.254), Dst: 192.168.1.1 (192.168.1.1)
Transmission Control Protocol, Src Port: cisco-sccp (2000), Dst Port: 50202 (50202), Seq: 1741,
Skinny Client Control Protocol
```

```
Data length: 36
Header version: Basic (0x00000000)
Message ID: ConnectionStatisticsReq (0x00000107)
Directory number: 4755001
Call identifier: 13
Stats processing type: doNotClearStats (1)
```

```
Internet Protocol Version 4, Src: 192.168.1.254 (192.168.1.254), Dst: 192.168.1.1 (192.168.1.1)
Transmission Control Protocol, Src Port: cisco-sccp (2000), Dst Port: 50202 (50202), Seq: 1833,
Skinny Client Control Protocol
```

```
Data length: 36
Header version: Basic (0x00000000)
Message ID: ConnectionStatisticsReq (0x00000107)
Directory number: 4755001
Call identifier: 13
Stats processing type: clearStats (0)
```

```
Internet Protocol Version 4, Src: 192.168.1.1 (192.168.1.1), Dst: 192.168.1.254 (192.168.1.254)
Transmission Control Protocol, Src Port: 50202 (50202), Dst Port: cisco-sccp (2000), Seq: 377,
Skinny Client Control Protocol
```

```
Data length: 64
Header version: Basic (0x00000000)
Message ID: ConnectionStatisticsRes (0x00000023)
Directory number: 4755001
Call identifier: 13
Stats processing type: doNotClearStats (1)
Packets sent: 389
Octets sent: 66908
Packets Received: 380
Octets received: 65360
Packets lost: 0
```

# Na druhé straně se musí tón vrátit na „položené sluchátko“

---

## Skinnny Client Control Protocol

Data length: 20

Header version: Basic (0x00000000)

Message ID: StartToneMessage (0x00000082)

Tone: InsideDialTone (0x00000021)

Line instance: 1

Call identifier: 1

# Více CCM na cestě – vzdálené volání

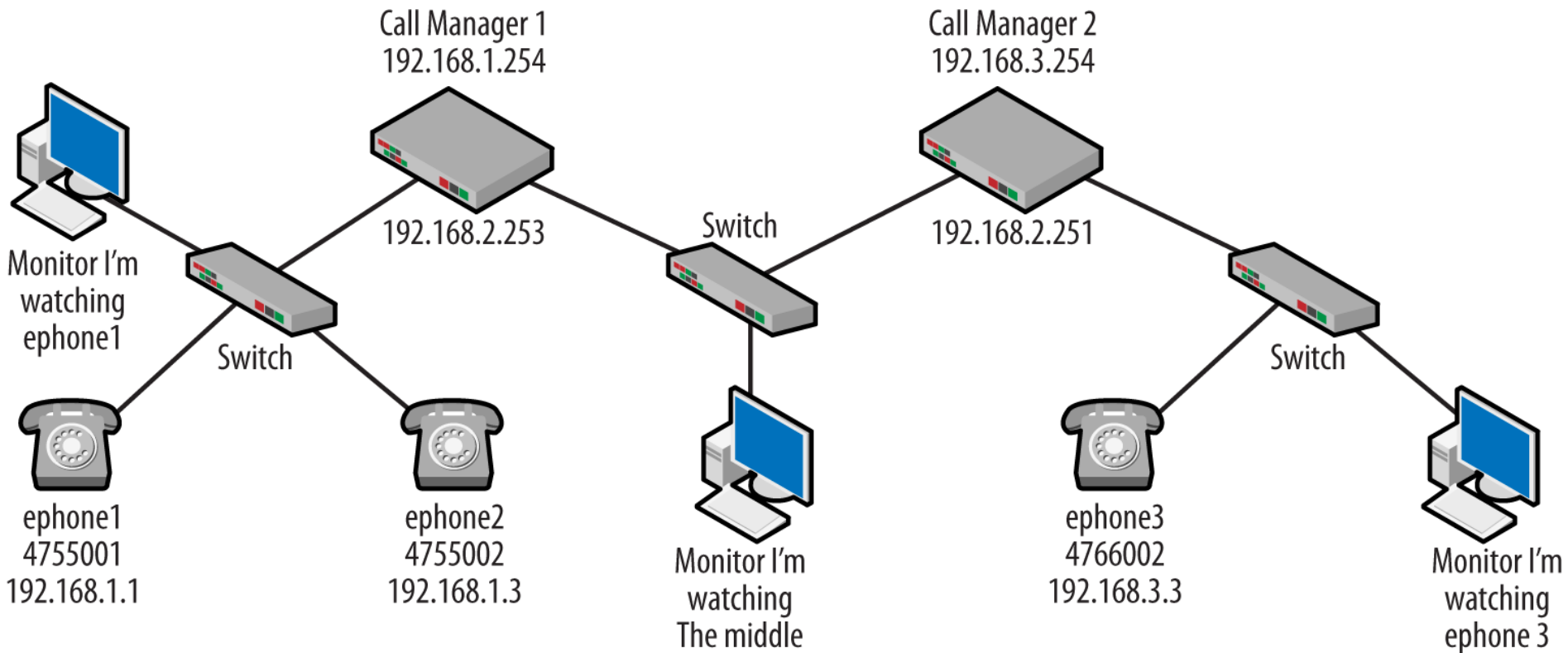

# Určení, kam s tím

---

```
dial-peer voice 1  
voip destination-pattern 475....  
session target ipv4:192.168.2.253  
incoming called-number
```



# CCM spolu komunikují prostřednictvím H.225

5	192.168.2.254	192.168.2.253	H.225.0 CS: setup OpenLogicalChannel
6	192.168.2.253	192.168.2.254	H.225.0 CS: callProceeding OpenLogicalChannel
7	192.168.2.253	192.168.2.254	H.225.0 CS: alerting
8	192.168.2.254	192.168.2.253	TCP 63780 > h323hostcall [ACK] Seq=312 Ack=190 Win=2974 Len=0
10	192.168.2.253	192.168.2.254	H.225.0 CS: connect
11	192.168.2.253	192.168.2.254	H.225.0 CS: notify
12	192.168.2.254	192.168.2.253	TCP 63780 > h323hostcall [ACK] Seq=312 Ack=351 Win=2813 Len=0
13	192.168.2.253	192.168.2.254	RTP PT=ITU-T G.729, SSRC=0x7E402FD, Seq=2627, Time=407040, Mark

# CCM si vymění čísla telefonů

```
Internet Protocol Version 4, Src: 192.168.2.254 (192.168.2.254), Dst: 192.168.2.253 (192.168.2.253)  
Transmission Control Protocol, Src Port: 63780 (63780), Dst Port: h323hostcall (1720), Seq: 1, Ack:  
TPKT, Version: 3, Length: 311
```

Q.931

```
Protocol discriminator: Q.931  
Call reference value length: 2  
Call reference flag: Message sent from originating side  
Call reference value: 0004  
Message type: SETUP (0x05)
```

- ⊕ Bearer capability
- ⊕ Calling party number: '4766002'
- ⊕ Called party number: '4755001'
- ⊕ User-user

H.225.0 CS



Kde je u CCM H.245?

---

# Obsah H.245 je zapouzdřen v H.225 (H.245 tunnelling)

```
Item 1
  FastStart item: 30 octets
  OpenLogicalChannel
    forwardLogicalChannelNumber: 1
    forwardLogicalChannelParameters
    reverseLogicalChannelParameters
    dataType: audioData (3)
      audioData: g729 (10)
        g729: 2
    multiplexParameters: h2250LogicalChannelParameters (2)
      h2250LogicalChannelParameters
        sessionID: 1
        mediaChannel: unicastAddress (0)
          unicastAddress: ipAddress (0)
            ipAddress
              network: 192.168.2.254 (192.168.2.254)
              tsapIdentifier: 17546
        mediaControlChannel: unicastAddress (0)
          unicastAddress: ipAddress (0)
            ipAddress
              network: 192.168.2.253 (192.168.2.253)
              tsapIdentifier: 18965
        1... .. silenceSuppression: True
        1... .. multipleCalls: True
        1... .. maintainConnection: True
        1... .. h245Tunnelling: True
```

H.245

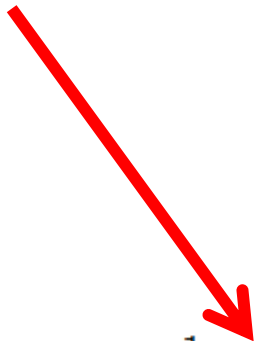

# Mezi CCM se RTCP používá, na rozdíl od komunikace mezi telefony

```
Ethernet II, Src: Cisco_f6:aa:90 (00:1c:58:f6:aa:90), Dst: Cisco_f4:c2:11 (00:1c:58:f4:c2:11)
Internet Protocol Version 4, Src: 192.168.2.254 (192.168.2.254), Dst: 192.168.2.253 (192.168.2.253)
User Datagram Protocol, Src Port: 17546 (17546), Dst Port: 18964 (18964)
Real-Time Transport Protocol
```

```
Ethernet II, Src: Cisco_f4:c2:11 (00:1c:58:f4:c2:11), Dst: Cisco_f6:aa:90 (00:1c:58:f6:aa:90)
Internet Protocol Version 4, Src: 192.168.2.253 (192.168.2.253), Dst: 192.168.2.254 (192.168.2.254)
User Datagram Protocol, Src Port: 18964 (18964), Dst Port: 17546 (17546)
Real-Time Transport Protocol
```

```
Ethernet II, Src: Cisco_f6:aa:90 (00:1c:58:f6:aa:90), Dst: Cisco_f4:c2:11 (00:1c:58:f4:c2:11)
Internet Protocol Version 4, Src: 192.168.2.254 (192.168.2.254), Dst: 192.168.2.253 (192.168.2.253)
User Datagram Protocol, Src Port: 17547 (17547), Dst Port: 18965 (18965)
Real-time Transport Control Protocol (Receiver Report)
Real-time Transport Control Protocol (Source description)
```

```
Ethernet II, Src: Cisco_f4:c2:11 (00:1c:58:f4:c2:11), Dst: Cisco_f6:aa:90 (00:1c:58:f6:aa:90)
Internet Protocol Version 4, Src: 192.168.2.253 (192.168.2.253), Dst: 192.168.2.254 (192.168.2.254)
User Datagram Protocol, Src Port: 18965 (18965), Dst Port: 17547 (17547)
Real-time Transport Control Protocol (Receiver Report)
Real-time Transport Control Protocol (Source description)
```

# Skinny je z hlediska bezpečnosti omezením, např. nepodporuje NAT

The screenshot shows the Check Point SmartDashboard interface. The main window displays the configuration for the 'Skinny Client Control Protocol'. The left sidebar shows a tree view of network objects, with 'VoIP' expanded to show 'SCCP (Skinny)\*'. The main pane shows the configuration for 'Skinny Client Control Protocol\*' with the following settings:

- Verify SCCP header content
- Drop multicast RTP connections

Below the configuration, the following information is displayed:

- Attack ID:** CPAIS303
- Last Update:** 01-February-2005
- Supported from Version:** R55W
- Severity:** Critical

**SmartDefense Protection:**

SCCP (Skinny Client Control Protocol) controls telephony gateways from external call control devices called Call Agents (also known as Media Gateway Controllers). SmartDefense provides full connectivity and network level and security for SCCP based VoIP communication. All SCCP traffic is inspected, and legitimate traffic is allowed to pass while attacks are blocked. All SmartDefense capabilities are supported, such as anti-spoofing and protection against Denial of Service attacks. Fragmented packets are examined and secured using kernel based streaming. However, NAT on SCCP devices is not supported. In addition, SmartDefense restricts handover locations, and controls signalling and data connections. SmartDefense tracks state and verifies that the state is valid for all SCCP message. For a number of key messages, it also verifies of existence and correctness of the message parameters. SmartDefense can perform additional content security checks for SCCP connections, thereby providing a greater level of protection.

The status bar at the bottom of the window shows 'Done', '192.168.126.1', and 'Read/Write'.

# Výměna zpráv s CCM

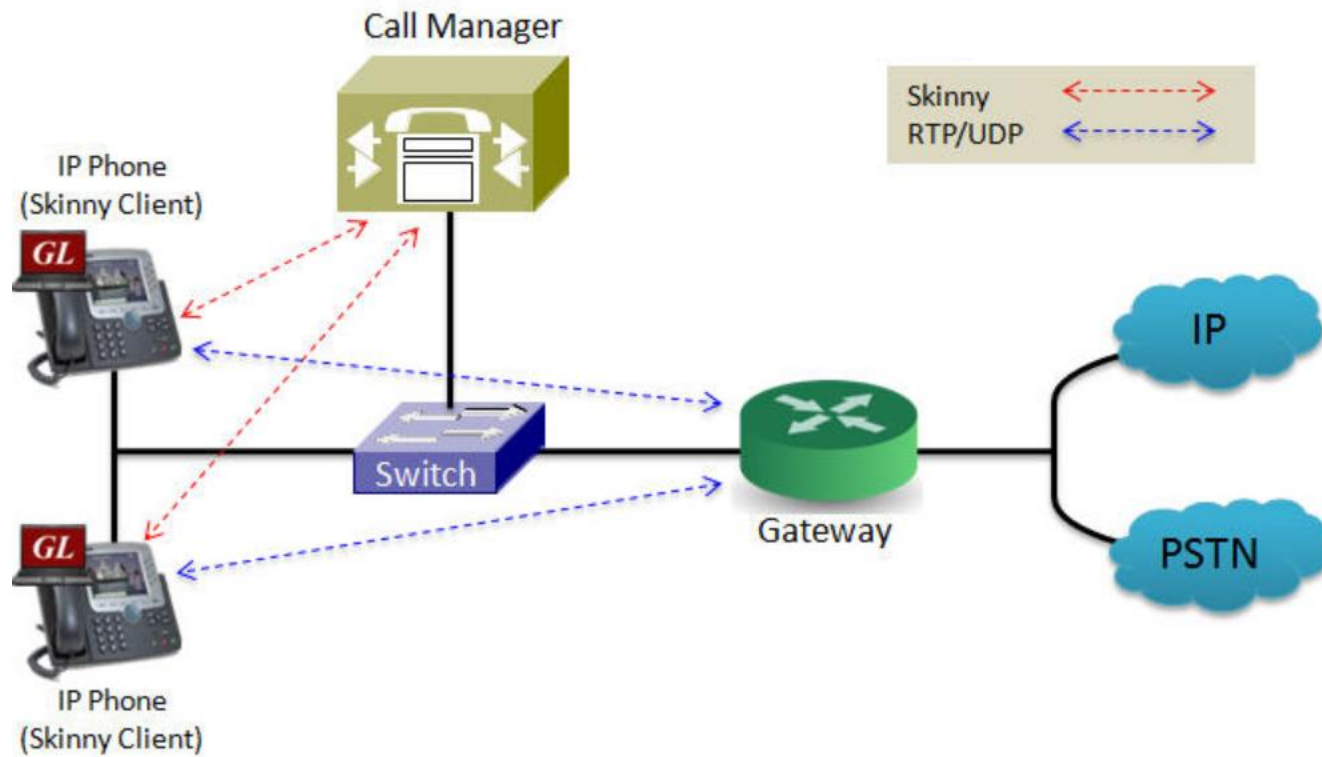



# Výměna zpráv s CCM

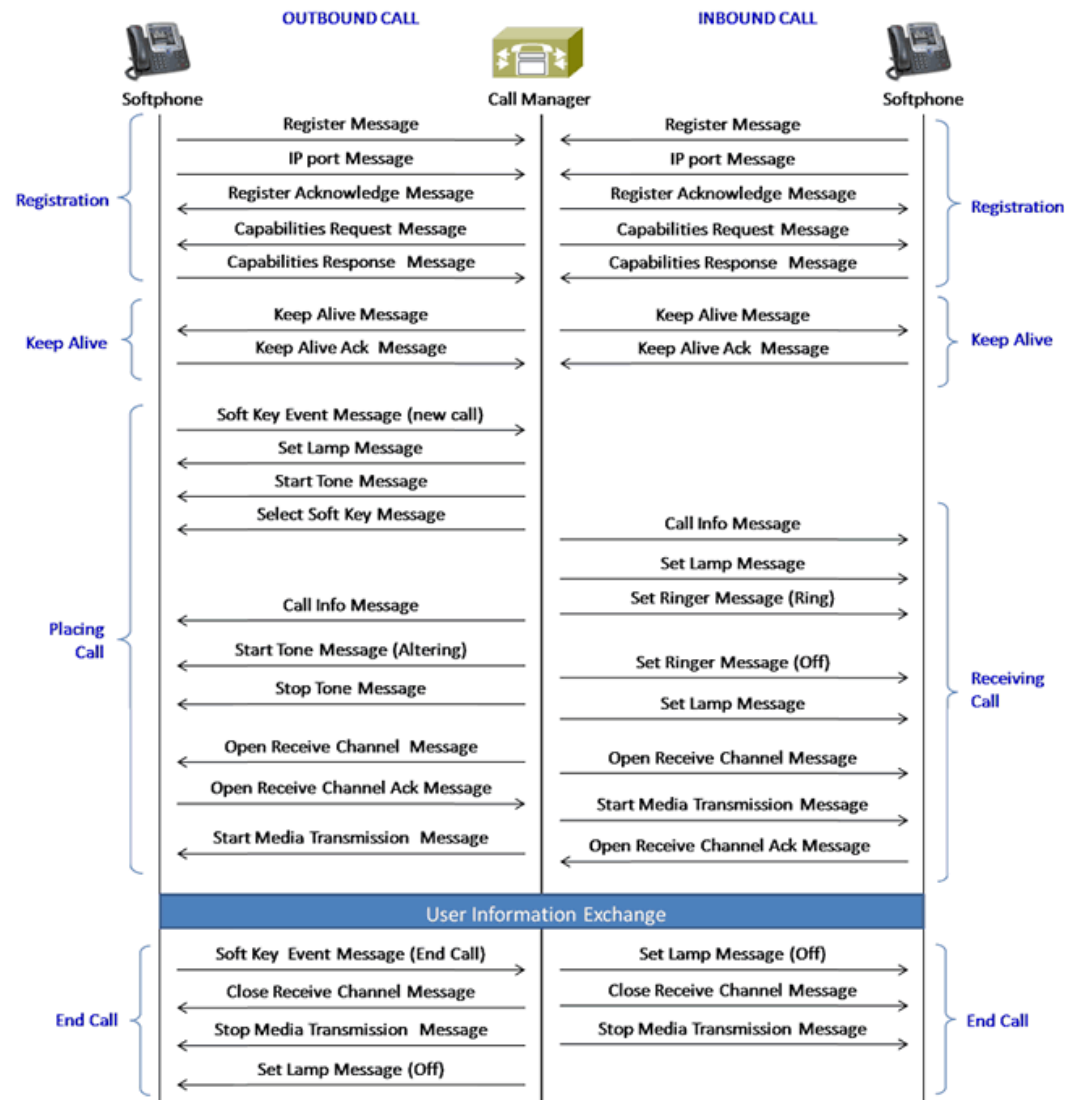

# SRST

## (Survivable Remote Site Telephony)

---

- vlastnost routeru na pobočce, aby převzal funkce Call Agenta, když vypadne spojení s CallManagerem v centrále
- jde o záložní řešení, které obsahuje pouze základní funkce CUCM

---

## 2. Typy volání

# Jaké známe typy volání

---

- Místní volání
- Volání přes ústřednu
- Volání z IP sítě do PSTN sítě
- Volání PLAR (Private Line, Automatic Ringdown)
- Volání přes dvě ústředny (PBX-to-PBX)
- Volání přes dva agenty volání (CallManager-to-CallManager)
- Volání ze sítě mimo síť (On-net to off-net )

# Místní volání

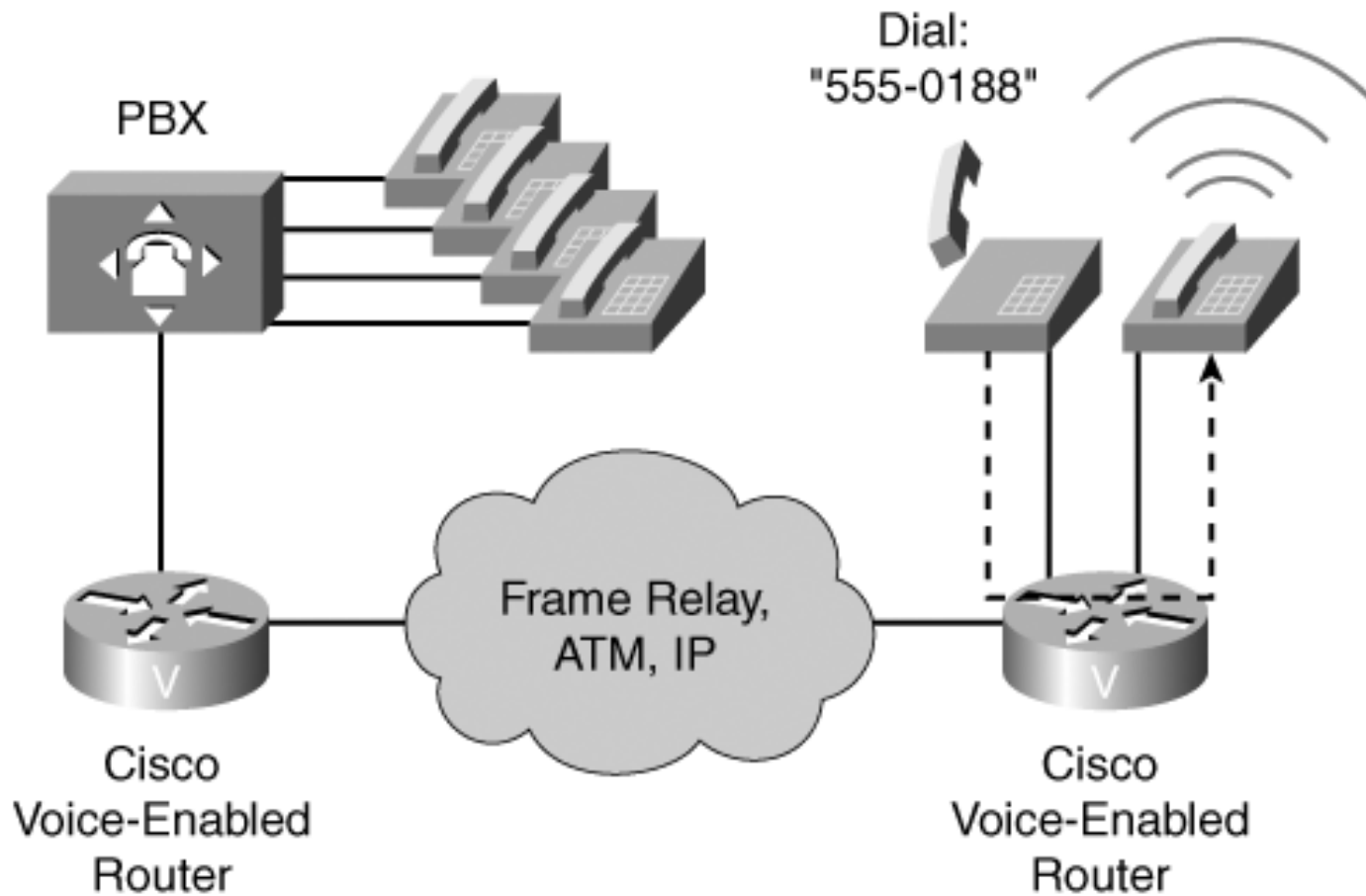

# Volání přes ústřednu

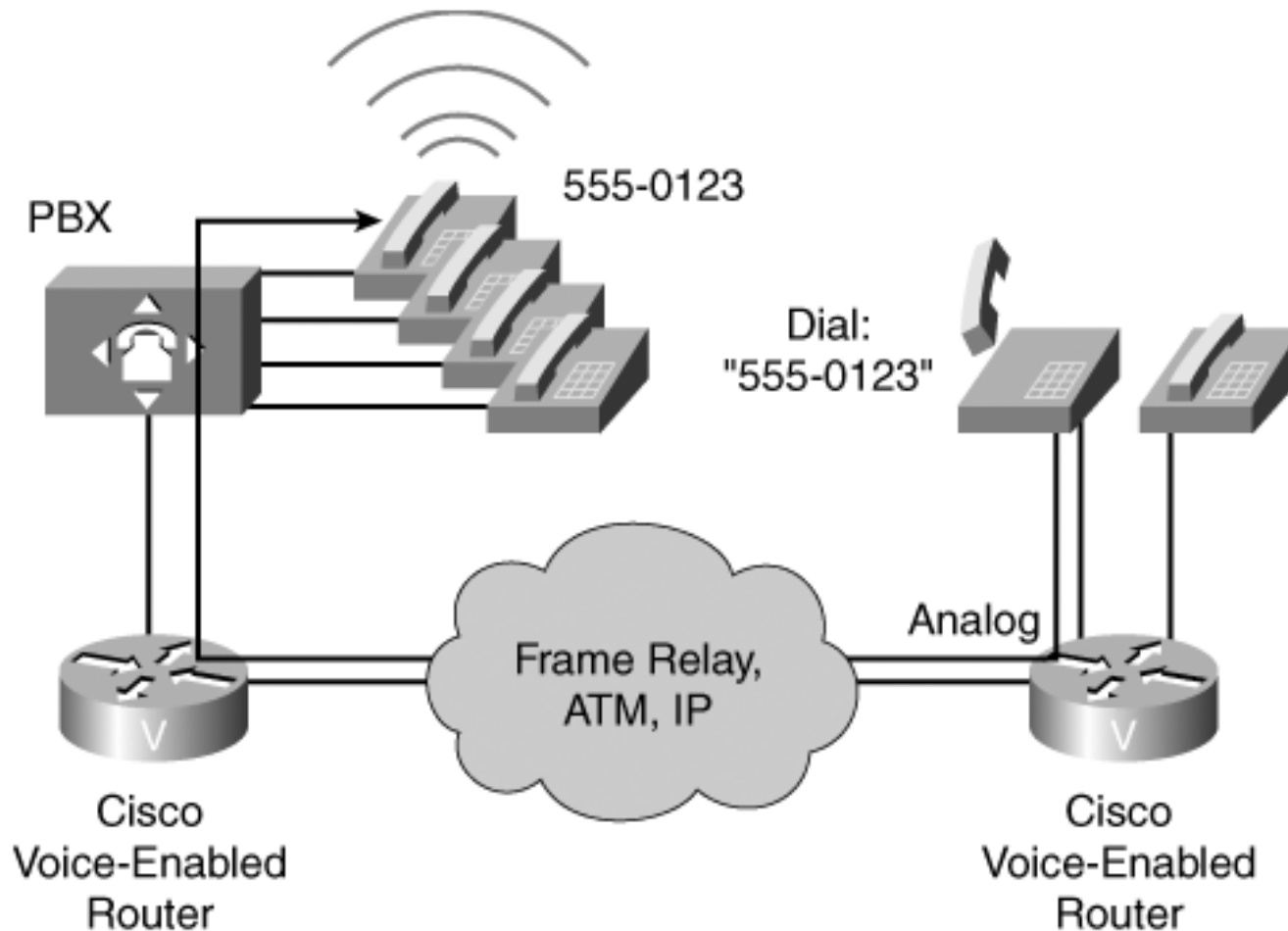

# Volání z IP sítě do PSTN sítě

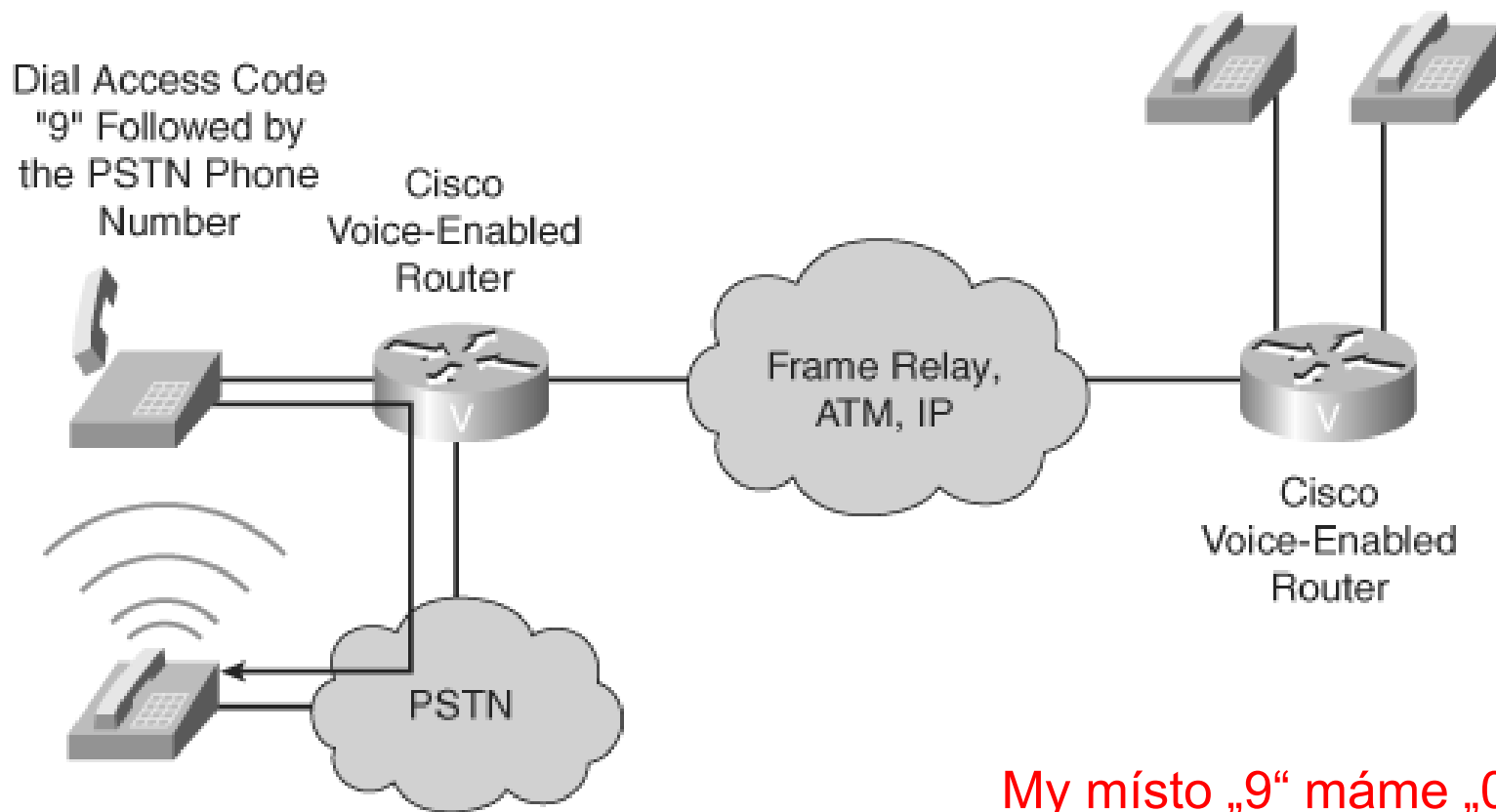

My místo „9“ máme „0“

# PLAR (Private-line automatic ringdown)

Při zvednutí sluchátka volání na pevnou linku

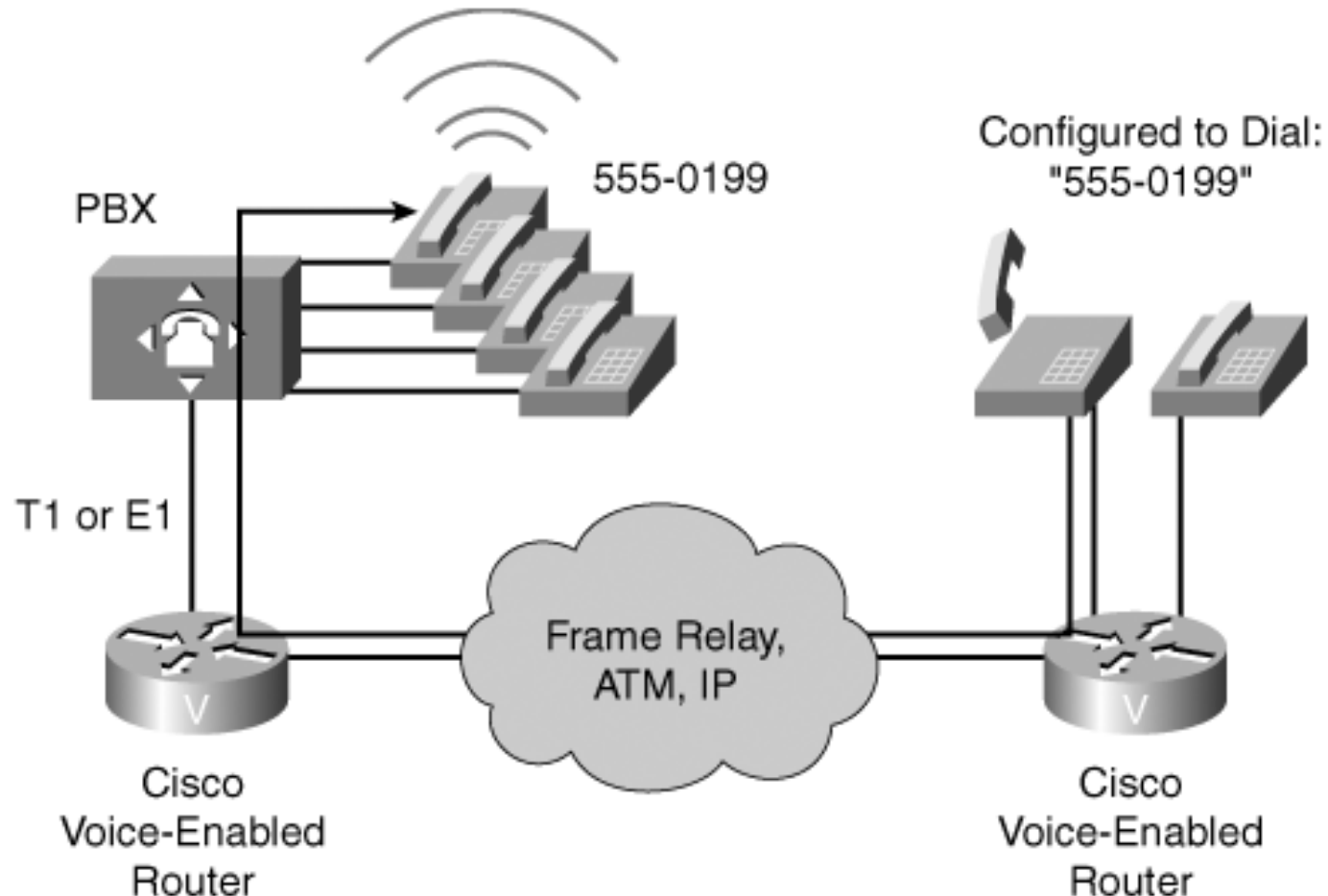



# Volání přes dvě ústředny

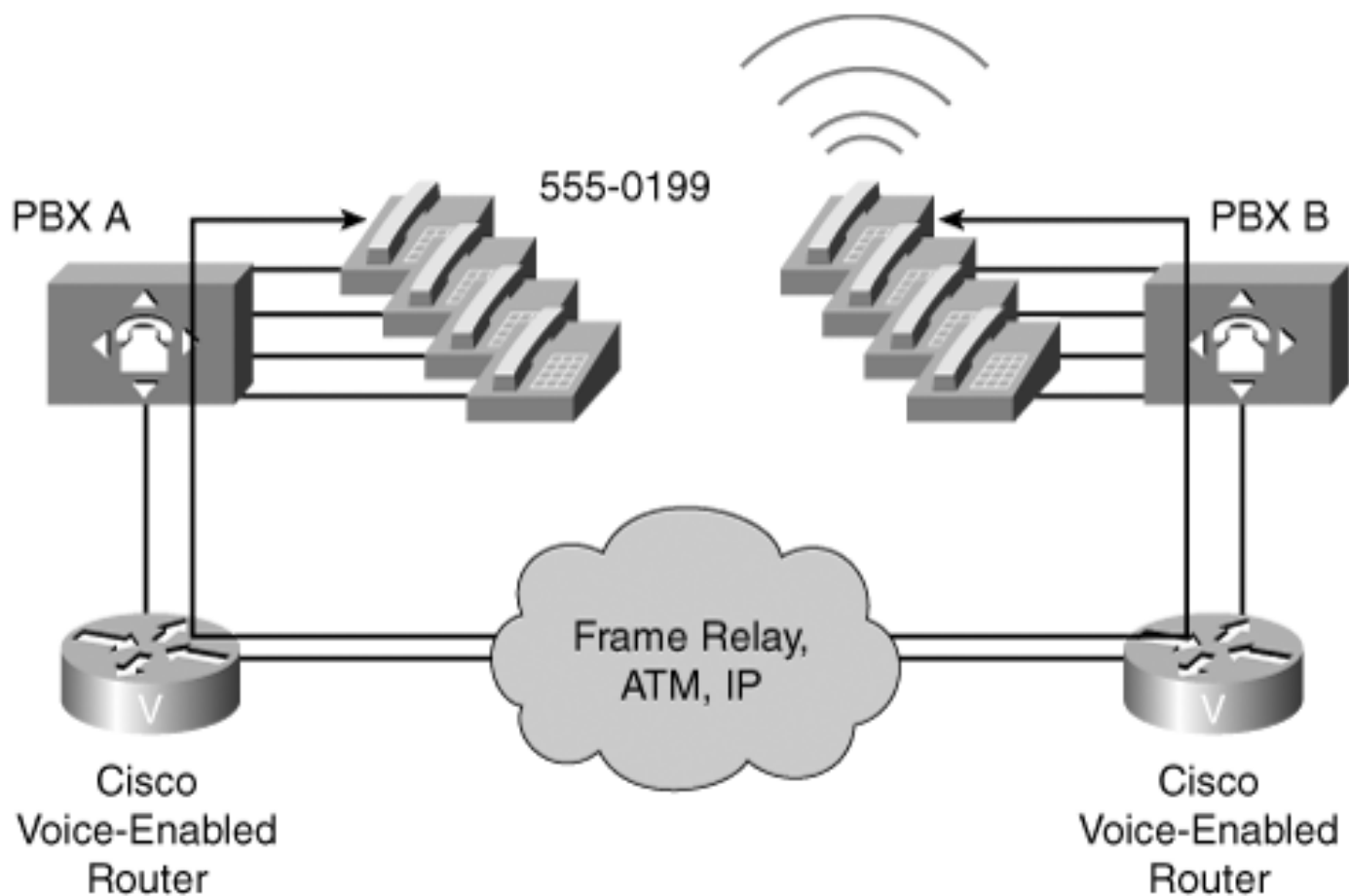

# Volání přes dva agenty volání

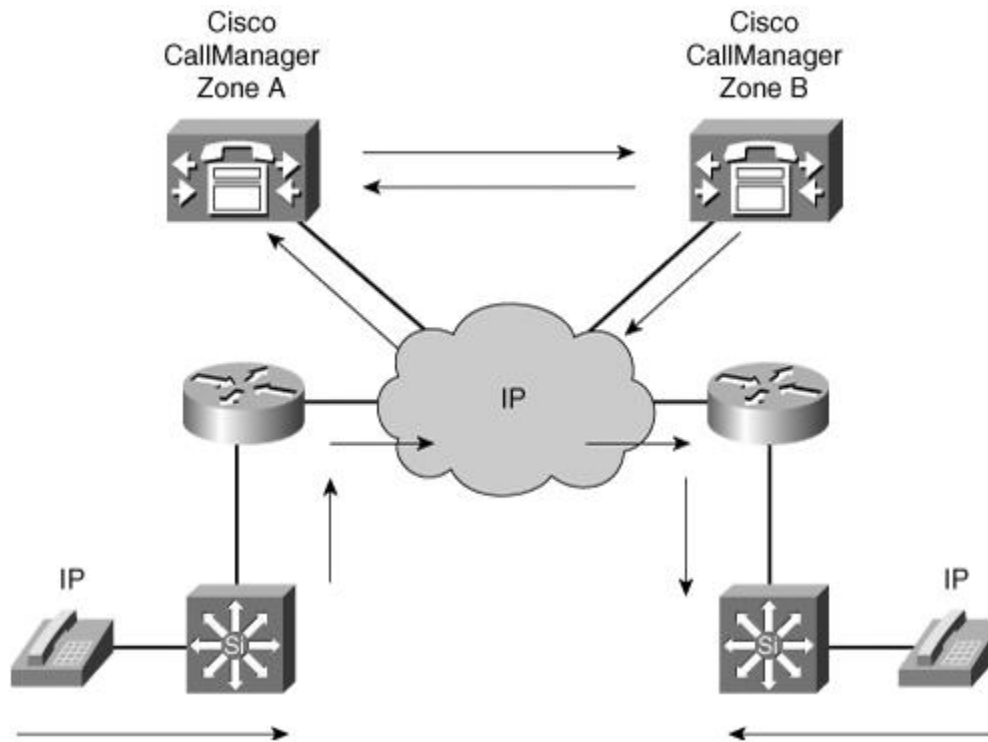

# Volání ze sítě mimo síť

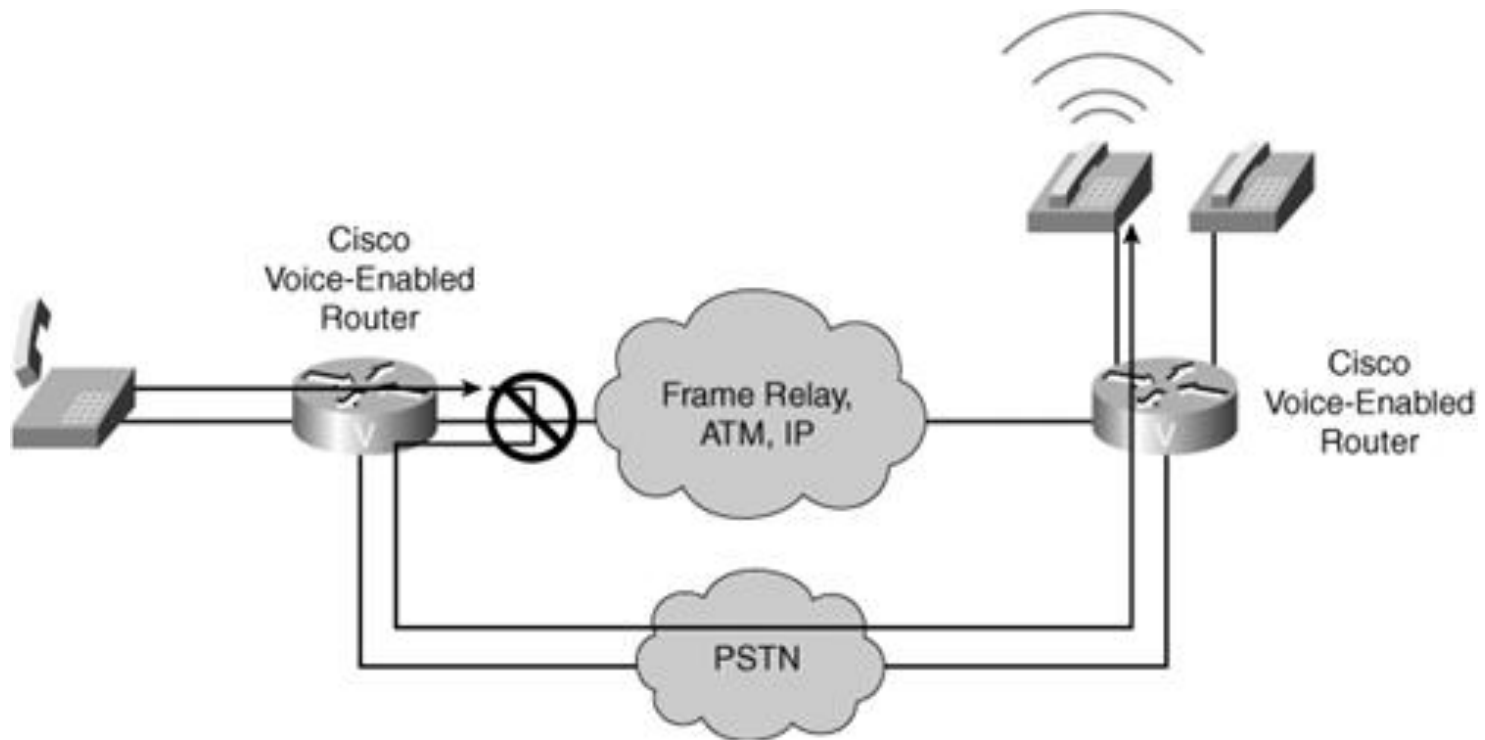

---

## 3. Konfigurace Cisco IP telefonu

# Opakování: Signalizace loop-start

Signalizační technika zajišťující indikaci stavu zavěšeno, zvednuto

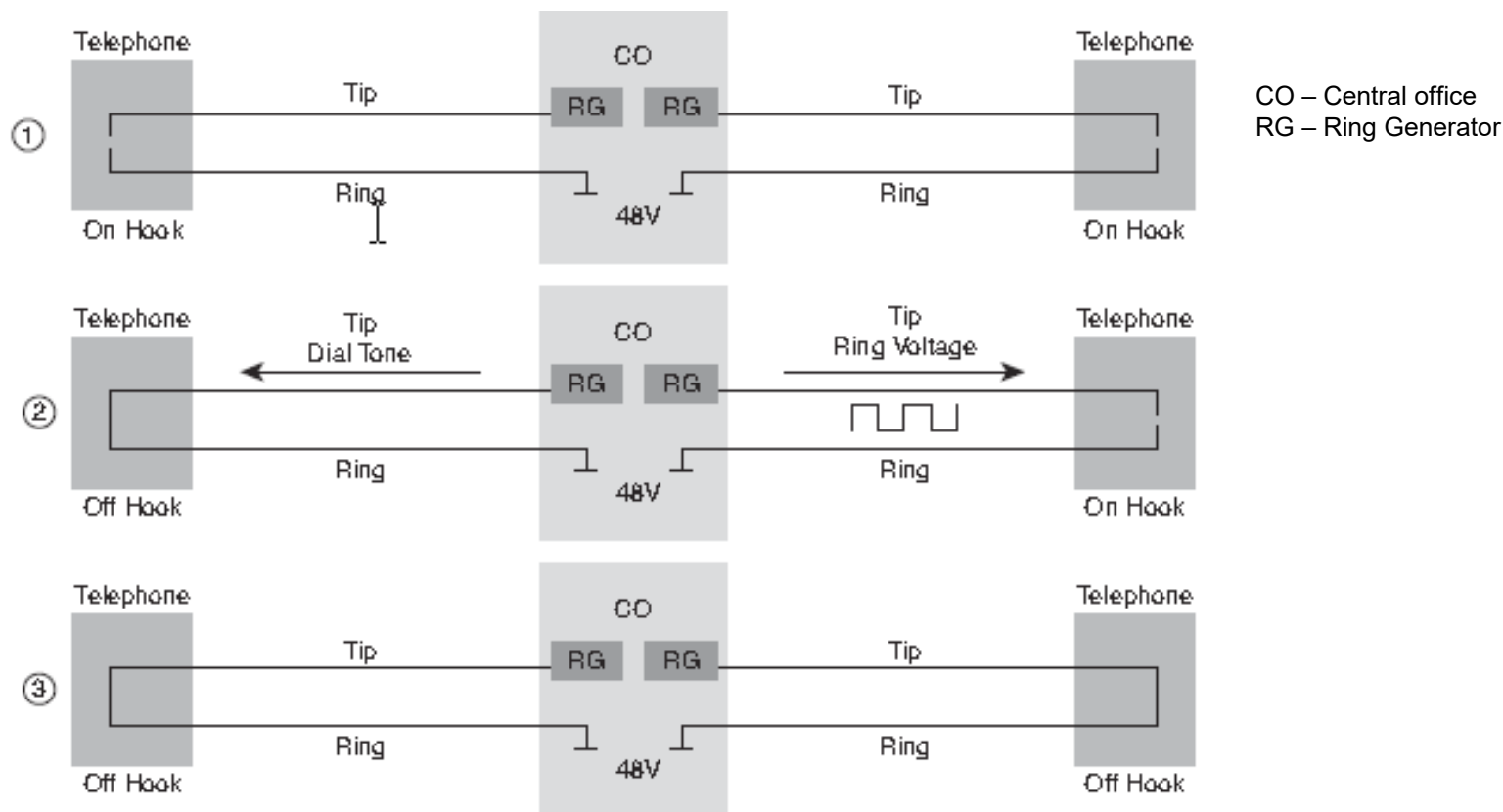

1. Nečinný stav
2. Volající zvedne a vytáčí číslo (uzavře se okruh), vyzvánění 20 Hz, 90 V stř.
3. Hovor je spojen (- 48 V ss)

# Signalizace ground-start

Signalizační technika zajišťující indikaci stavu zavěšeno, zvednuto

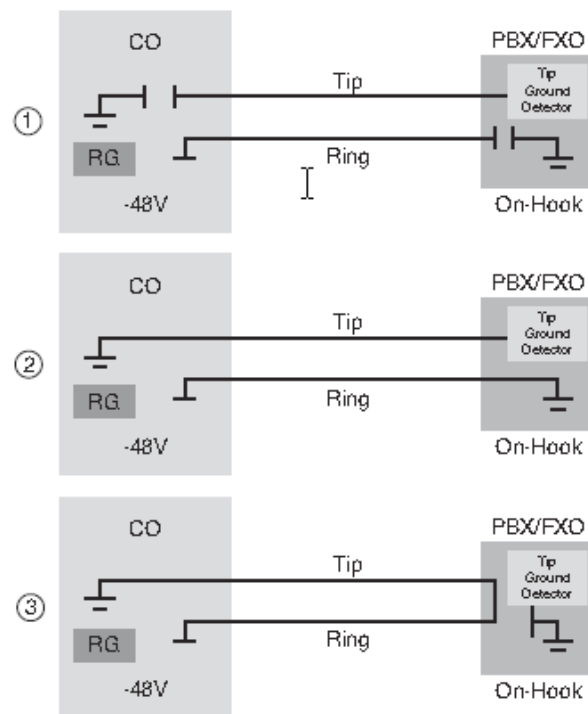

1. Nečinný stav. PBX a FXO neustále monitorují uzemnění linky tip a CO a FXS zase neustále monitorují uzemnění linky vyzvánění.
2. PBX nebo FXO uzemní vyzváněcí linku, CO či FXS zjistí zem a lince vyzvánění a uzemní tip linku, čímž FXO uvědomí o připravenosti na příjem.
3. PBX zjistí uzemnění linky tip, uzavře obě smyčky a zruší uzemnění linky vyzvánění.

# Opakování:

## Volba frekvence DMTF

---

<b>Frequencies</b>	<b>1209</b>	<b>1336</b>	<b>1477</b>
697	1	2	3
770	4	5	6
852	7	8	9
941	*	0	#

# Problém

---

Úsporné kodeky (např. G.729, G.723.1) jsou optimalizovány pro hlas a ne číslice



# Tlačítka tónové signalizace

697 Hz	1	2	3	A
770 Hz	4	5	6	B
852 Hz	7	8	9	C
941 Hz	*	0	#	D
	1209 Hz	1336 Hz	1477 Hz	1633 Hz

# Kde je v E1 umístěna adresní informace?

---

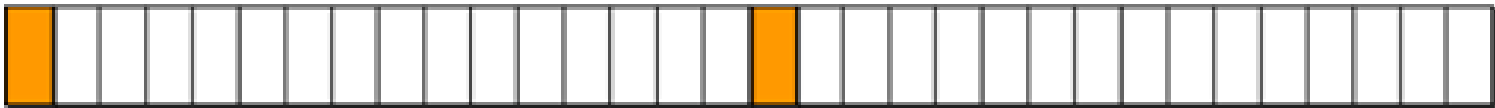

# Formát signalizace E1

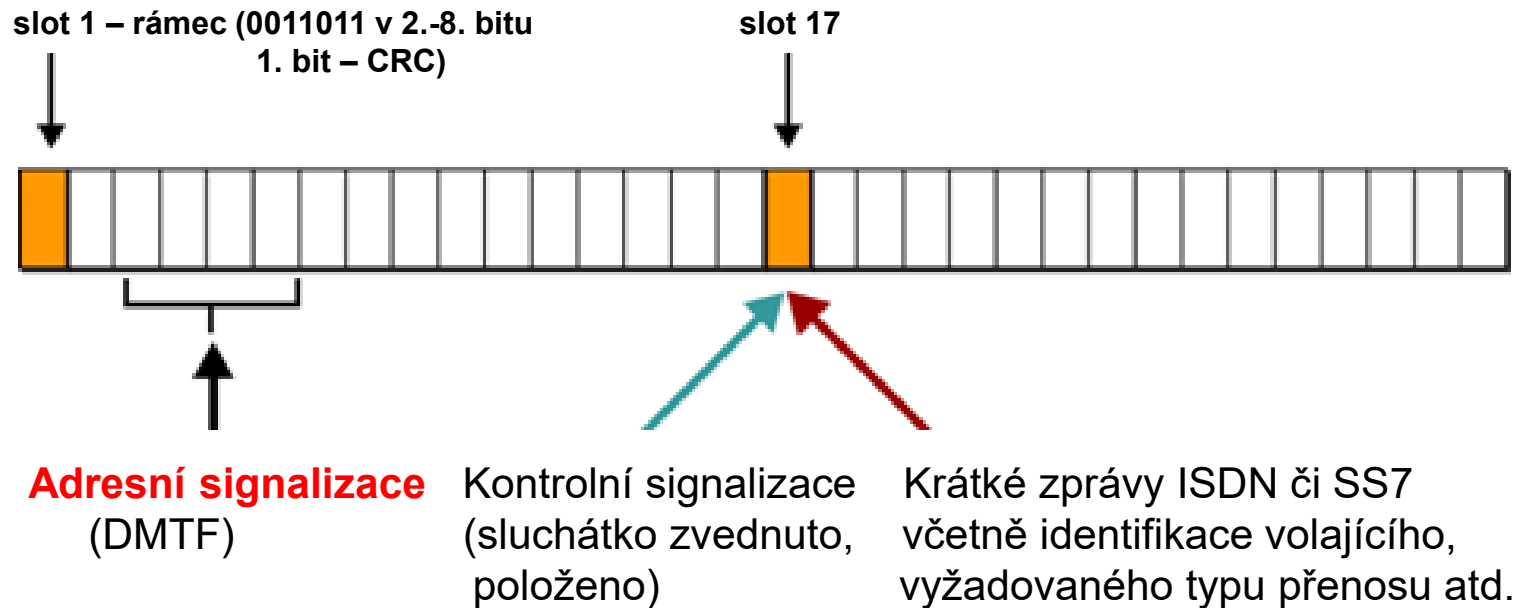

# ISDN 2B + D

(signalizace rozprostřena uvnitř datových kanálů)

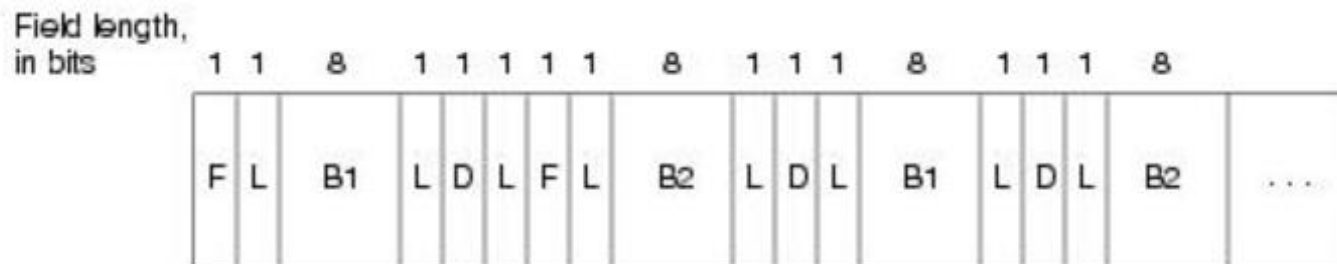

NT frame (network to terminal)

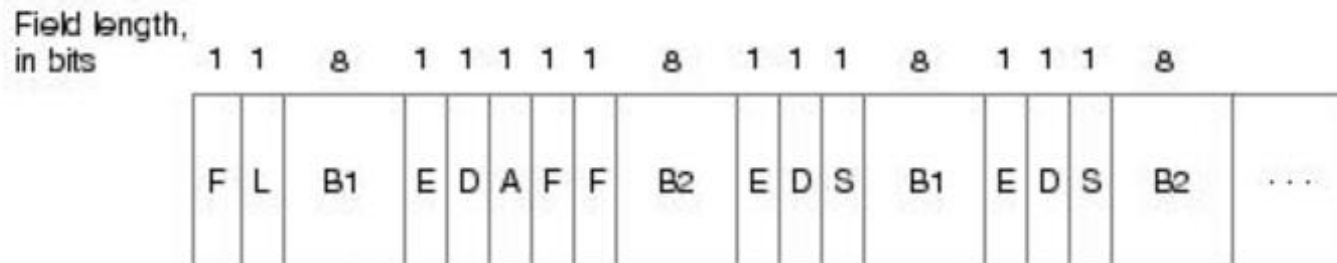

TE frame (terminal to network)

A = Activation bit

B1 = B1 channel bits

B2 = B2 channel bits

D = D channel (4 bits x 4000 frames/sec. = 16 kbps)

E = Echo of previous D bit

F = Framing bit

L = Load balancing

S = Spare bit

# Jak to vypadá na trunku E1

(signalizace sdružena vně datových kanálů)

Na E1 trunku se rámeček skládá z 32 timeslotů.  
Rámeček je posílán každých 125 usec (1/8000 sec).

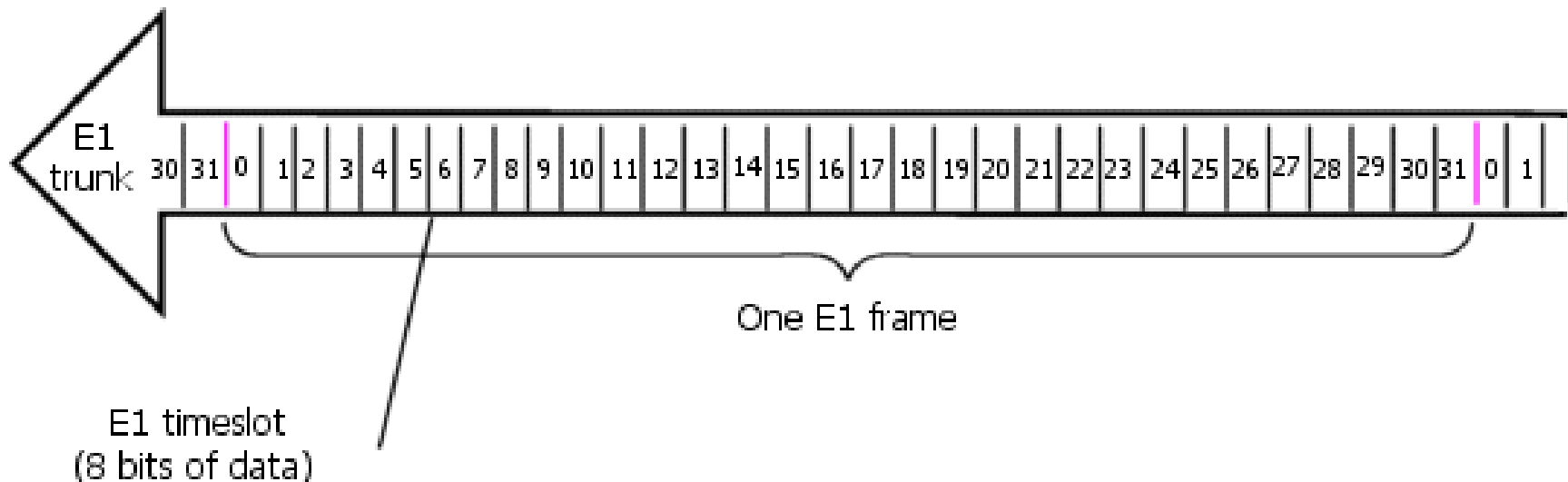

# E1 rámeč (signalizace 30B + D)

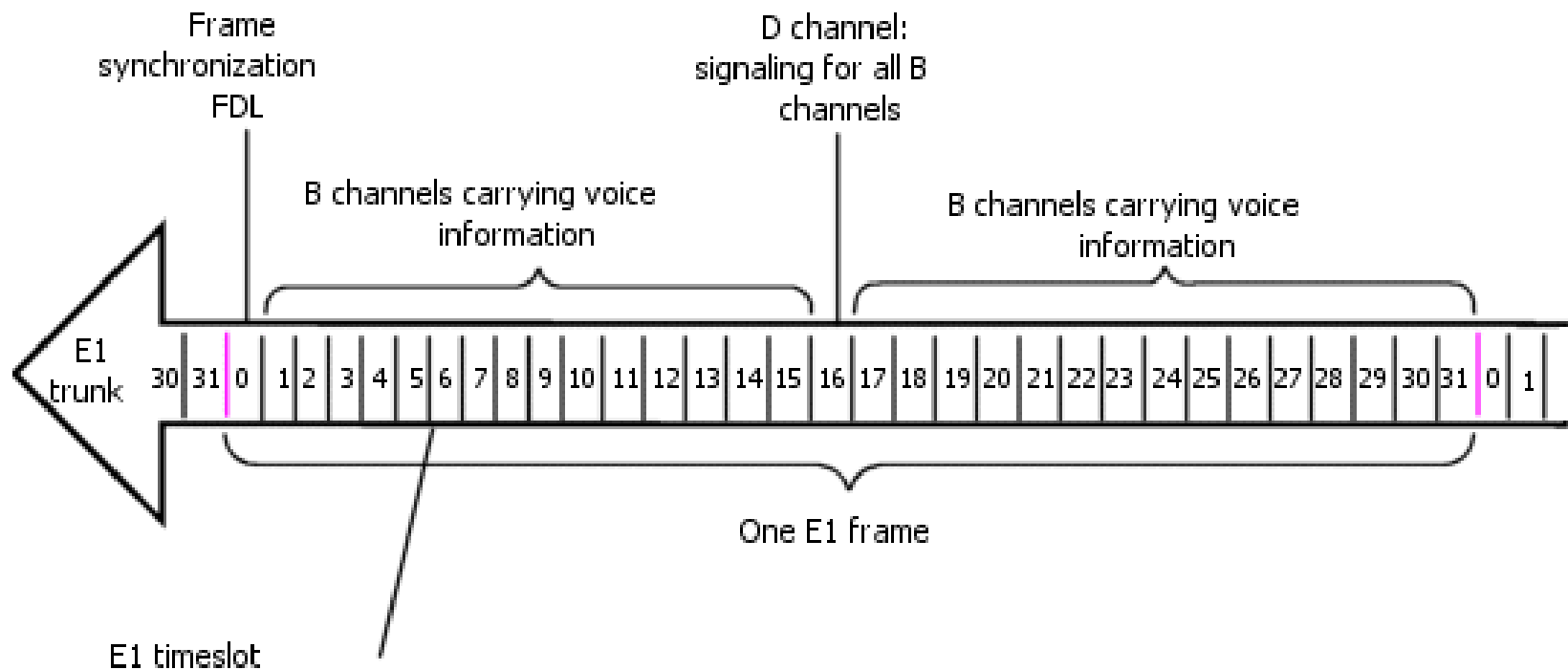

FDL – facilities data link

# Časové sloty v rámci multirámce CEPT E1

CEPT je zkratka pro European Conference of Postal and Telecommunications Administrations

V jednom 8 bit rámcí jsou dva kanály a tak by nebylo efektivní tam dávat ještě signalizaci, ta je shrnuta pro 15 rámců v tom 16.

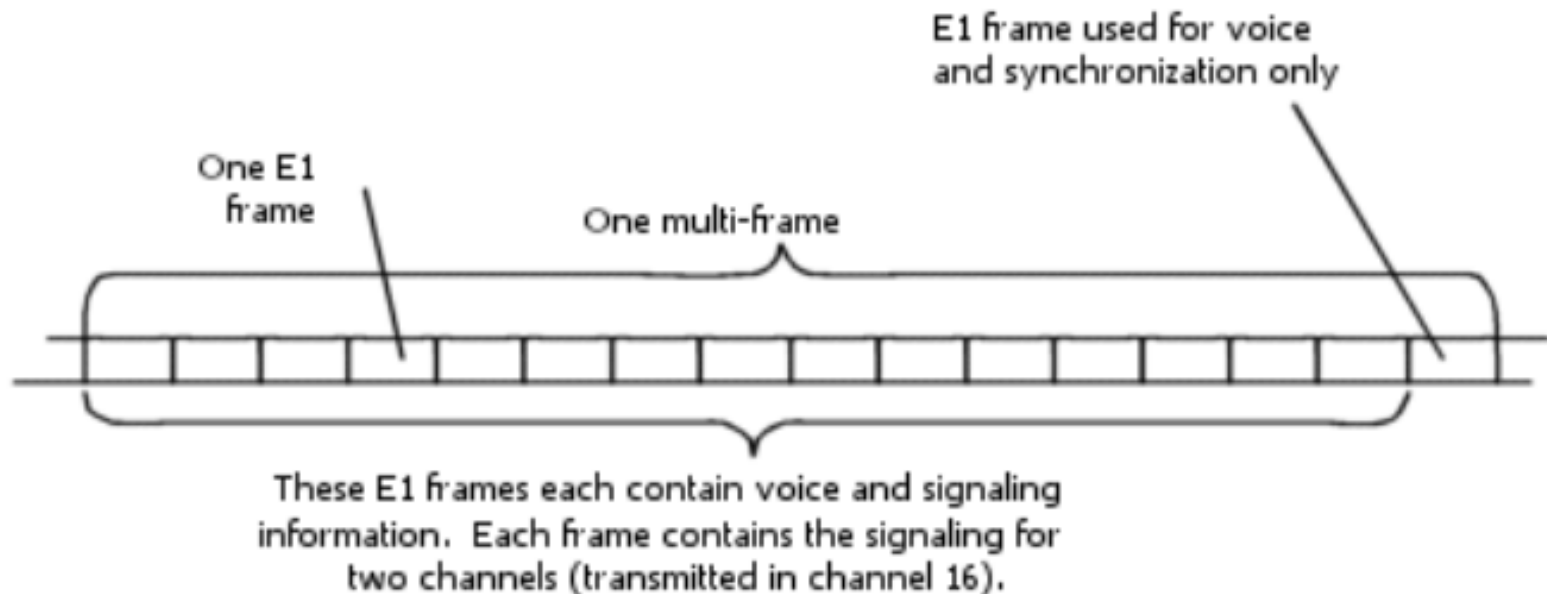

$$E1: 8 \times 8,000 \times 32 = 2,048 \text{ Mb/s}$$

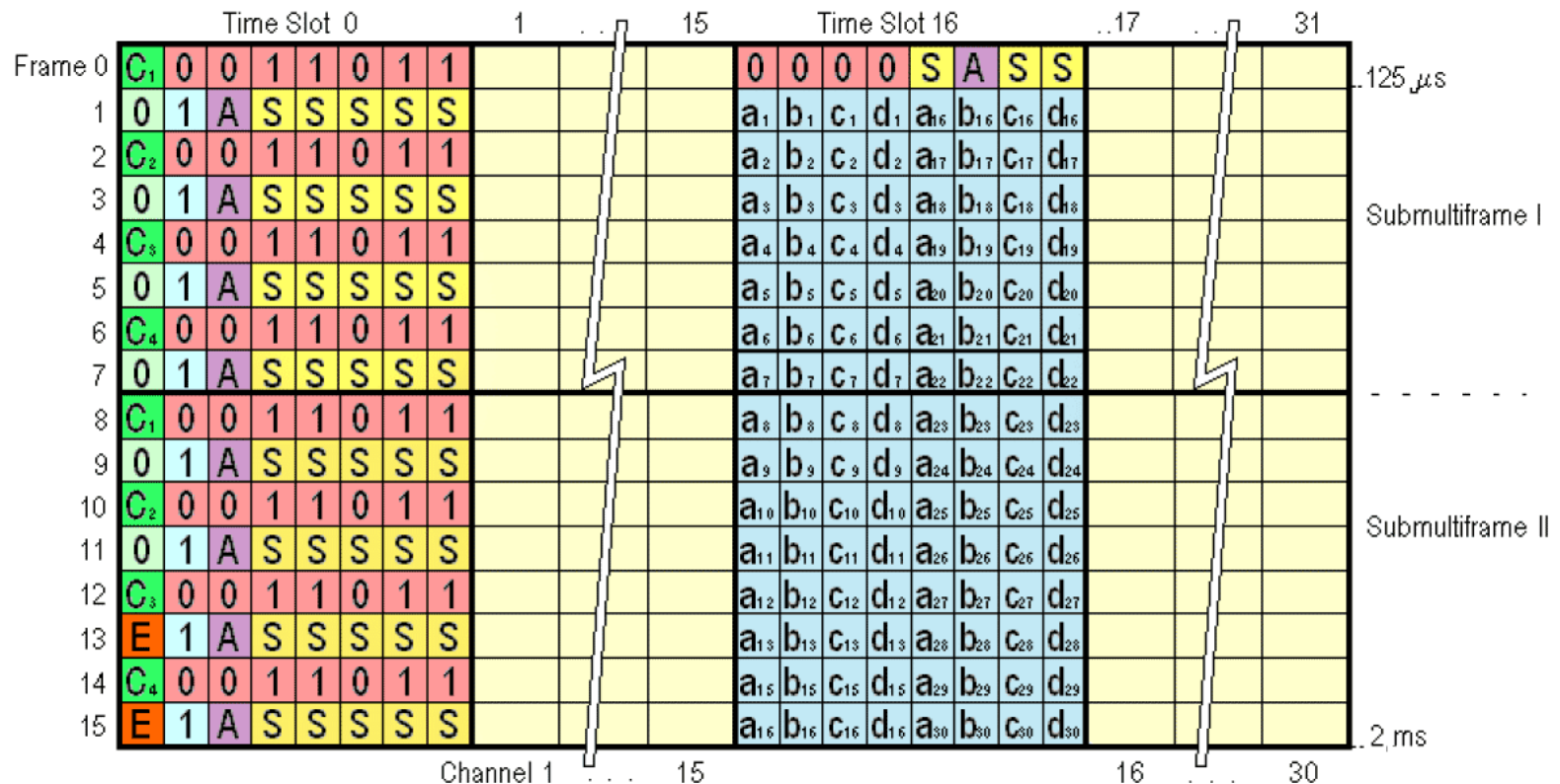

- 1 1 ... 0 Alignment Bits
- A Remote Alarm Indicator
- E CRC-4 Error Signaling Bits
- C<sub>1</sub> C<sub>2</sub> C<sub>3</sub> C<sub>4</sub> CRC-4 Bits

- a<sub>7</sub> b<sub>17</sub> c<sub>17</sub> d<sub>17</sub> Channel CAS Bits
- Channel Bytes
- S Spare Bits



# Konfigurace hlasového portu FXS 1

---



```
Router#configure terminal
Router(config)#voice-port 1/1/1
!Nastaveni hlasoveho konfiguracniho modu na port
Router(config-voiceport)#signal groundstart
!Vyber typu signalizace
Router(config-voiceport)#cptone CZ
!Nastaveni místního tonu
Router(config-voiceport)#ring cadence pattern01
!Vzor vyzvaneni (vzorek zvoneni, doba pauzy...)
```

# Konfigurace hlasového portu FXS 2

---

```
Router(config)#voice-port 1/1/1
Router(config-voiceport)#signal loopstart
Router(config-voiceport)#impedance 600r
Router(config-voiceport)#ring cadence pattern02
Router(config-voiceport)#output attenuation -2
Router(config-voiceport)#input gain 3
Router(config-voiceport)#echo-cancel coverage 32
```

Impedance je nastavena na 600  $\Omega$ .

Výstupní útlum je 2 dB, vstupní zisk 3 dB,

doba registrace echa byla posunuta z implicitních 8 ms na 32 ms

# Konfigurace portu FXO 1

## imituje nastavení telefonu

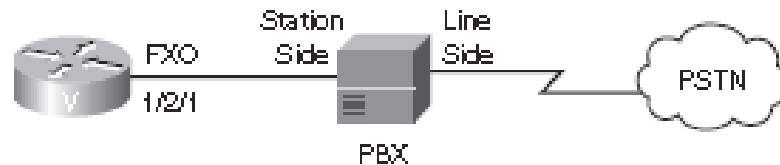

```
Router (config) #voice-port 1/2/1
Router (config-voiceport) #signal loopstart
Router (config-voiceport) #ring number 3
Router (config-voiceport) #dial-type pulse
```

Nastavuje se typ signalizace (loop-start, ground-start), typ vytáčení (pulzní, DTMF), počet zazvonění, po kterých FXO odpoví (např. 3)

# Konfigurace hlasového portu FXO 2

---

```
Router(config)#voice-port 0/0/0
Router(config-voiceport)#signal groundstart
Router(config-voiceport)#connection plar opx 4001
Router(config)#dial-peer voice 90 pots
Router(config-dialpeer)#destination-pattern 0T
Router(config-dialpeer)#port 0/0/0
```

Určení OPX (Off-Premises eXtension) PLAR, touto volbou si zajistí lokální reakci před vzdálenou odpovědí. Příchozí hovory typu plar jsou přesměrovány na číslo 4001. Dial peer je adresovatelný koncový bod spojení. T označuje řetězec číslic s proměnlivou délkou.

# Signalizace E&M

---

Slouží pro komunikaci mezi PBX či jinými telefonními přepínači.

Hlas a signalizace jsou přenášeny různými cestami.

Konfiguruje se: typ signalizace E&M, operace (2 dráty pro hlas FDX nebo 4 HDX).

Je 6 typů signalizace E&M:

Typ 1: nejběžnější v Severní Americe.

Typ 2: Pro citlivé prostředí, protože generuje minimální interferenci.

Typ 5: Mimo Severní Ameriku.

SSDC5: Velká Británie, ostatní se používají výjimečně.

Typ 1 a typ 2 jsou si podobné – pro signalizaci vedení E a M, zbývající dva páry se používají pro zvuk.

Fyzickým rozhraním je konektor RJ-48.

Tři typy signalizace přístupu:

*Immediate-start.* Volající si vyhradí linku zvednutím sluchátka na E a po min. 150 ms vyšle informace o adrese ve formě číslic DTMF nebo vytáčených pulsů.

*Wink-start.* Nejpoužívanější, odstraňuje kolize. Vysílající čeká na „mrknutí“ z druhé strany.

*Delay-start.* Volající po posečkání ověřuje, zda je na druhé straně sluchátko položeno.

# Konfigurace hlasového portu E&M 1

---

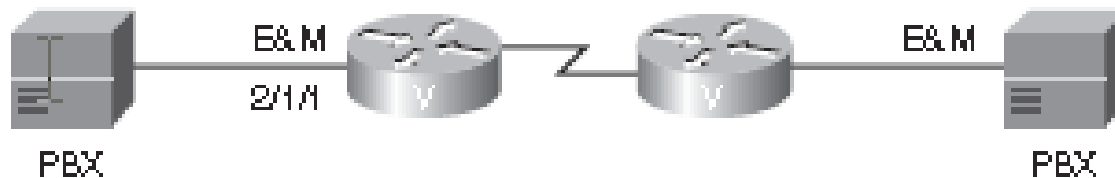

```
Router (config) #voice-port 2/1/1
Router (config-voiceport) #type 1
Router (config-voiceport) #operation 4-wire
Router (config-voiceport) #signal wink-start
```

# Konfigurace hlasového portu E&M 2

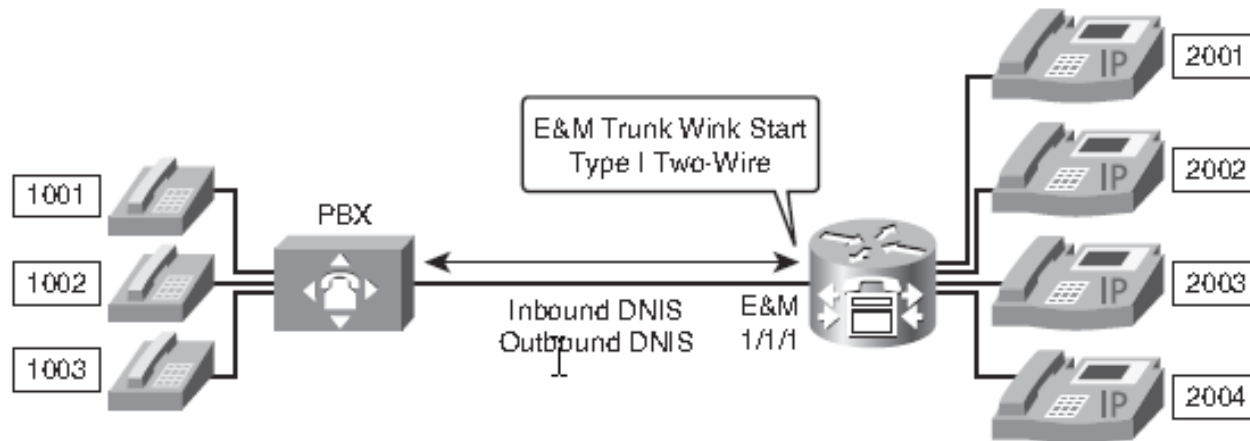

```
Router(config)#voice-port 1/1/1
Router(config-voiceport)#signal wink-start
Router(config-voiceport)#operation 2-wire
Router(config-voiceport)#type 1
Router(config-voiceport)#no shutdown
Router(config-voiceport)#exit
Router(config)#dial-peer voice 10 pots
Router(config-dialpeer)#destination-pattern 1...
Router(config-dialpeer)#direct-inward-dial
!Prime dovnitr smerovane pripojeni
Router(config-dialpeer)#forward-digits all
!Posilaji se dal vsechna cisla, nejen odpovidajici zastupnym znakum v pattern
Router(config-dialpeer)#port 1/1/1
```

# Je možné nastavit řadu časovačů

---

```
Router(config)#voice-port 1/1/1
```

```
Router(config-voiceport)#timeouts interdigit 20
```

! Maximalni doba cekani pri vytaceni na dalsi cislici v sekundach

```
Router(config-voiceport)#timeouts initial 20
```

! Maximalni doba cekani pri vytaceni na prvni cislici v sekundach



# Digitální hlasové porty

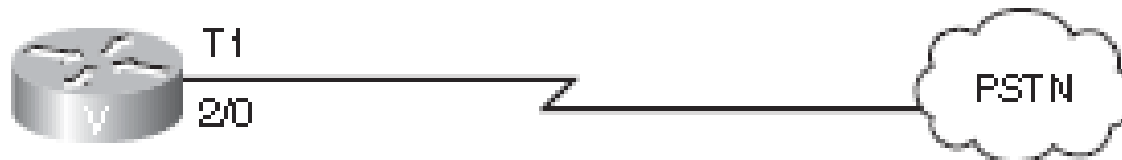

```
Router(config)#controller 2/0
Router(config-controller)#clock source line
! Hodinovy signal prichazi ze site
Router(config-controller)#framing esf
! Rozsireny superramec - viz P1-30
Router(config-controller)#linecode b8zs
! Kodovani bipolar with eight-zero substitution
! Eliminuje pro T1 osmice nul
```

Tři módy: controller-configuration, interface-configuration, voiceport-configuration.

# Opakování: Co je ESF?

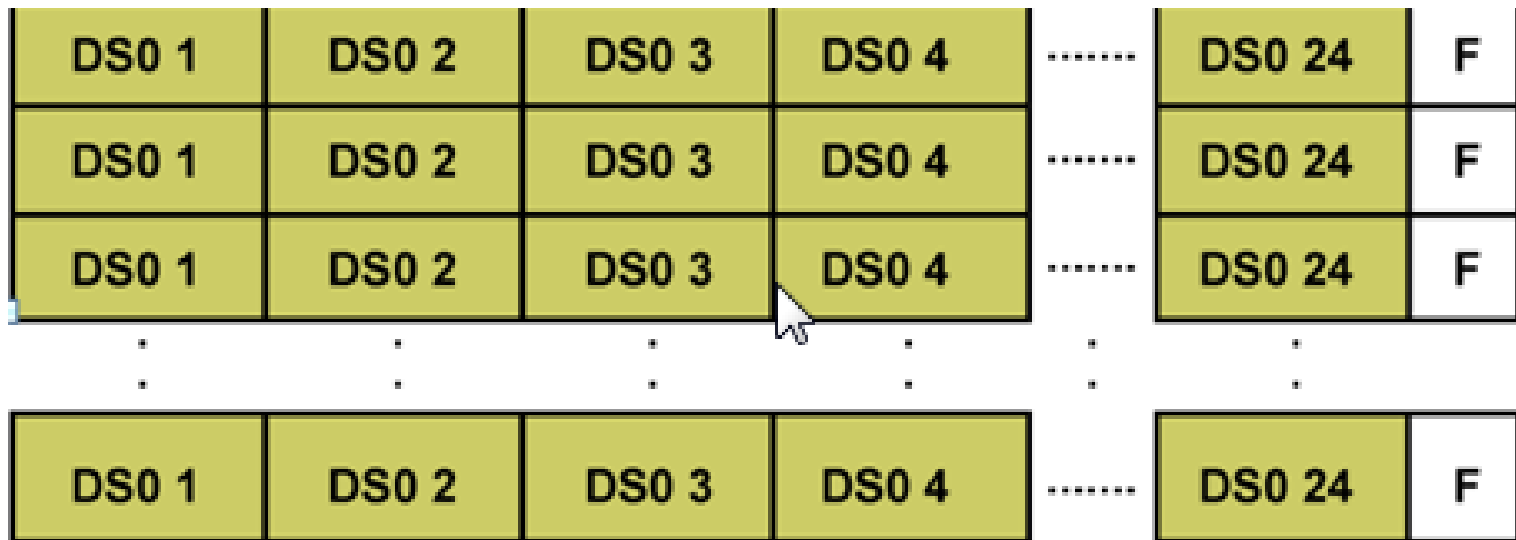

# Formát signalizace T1 a Extended SuperFrame

DS0 – 64 kb/s, F – Framing bit, 12 rámců – SF, **24 rámců – ESF**  $8 \times 24 + 1 = 193$  bitů

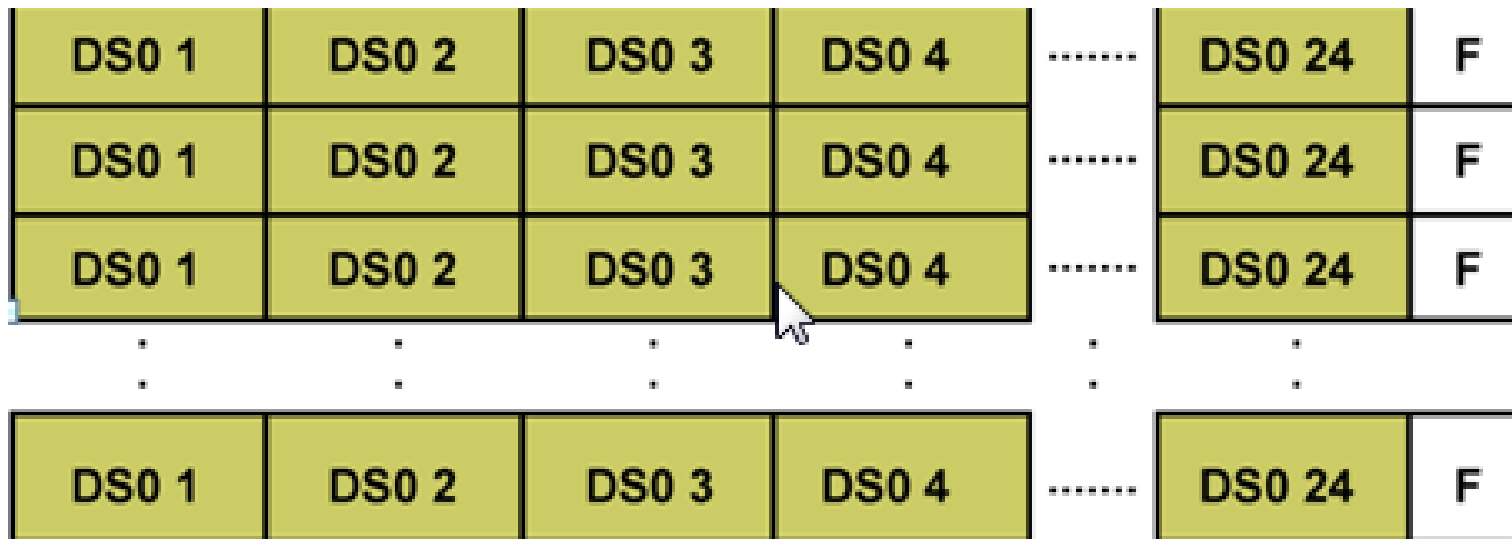

# T1: ISDN 23B+D

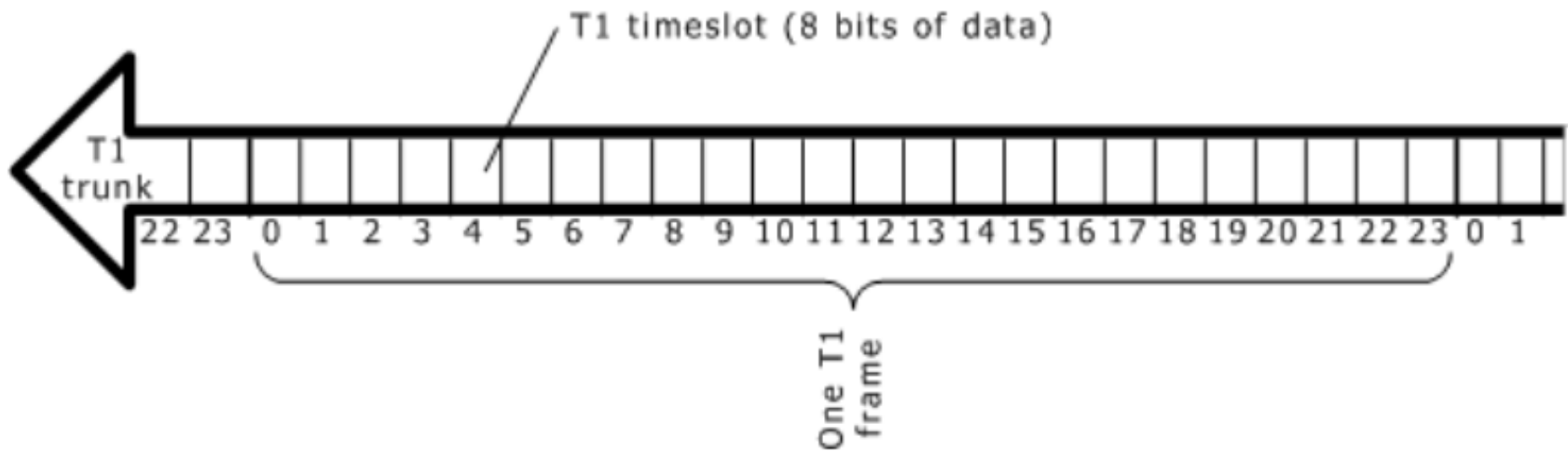

# D4 framing

- Na konec každého rámece je přilepen jeden framing bit (F bit) pro jejich oddělení
- Celkem má rámeček  $(24 \times 8) + 1 = 193$  bitů

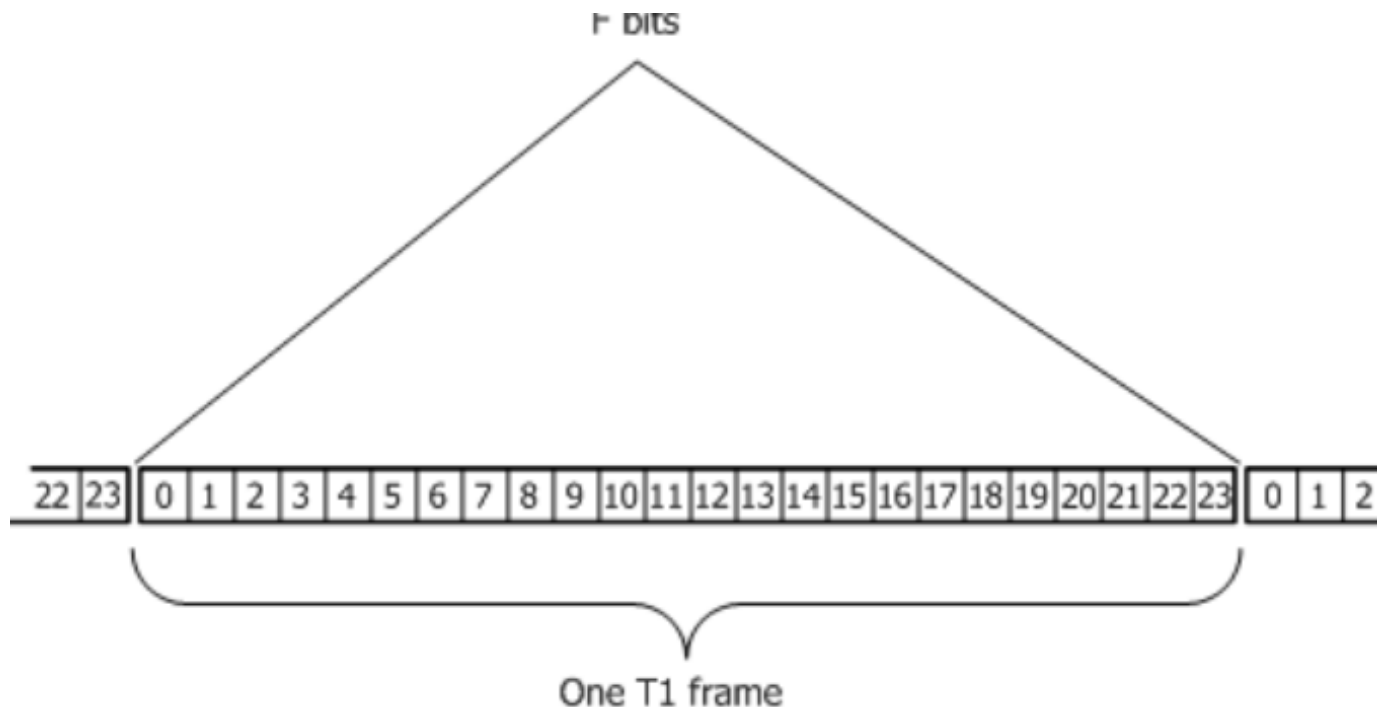

# Superframe

2 signalizační bity nám umožňují přenášet 4 signalizační zprávy

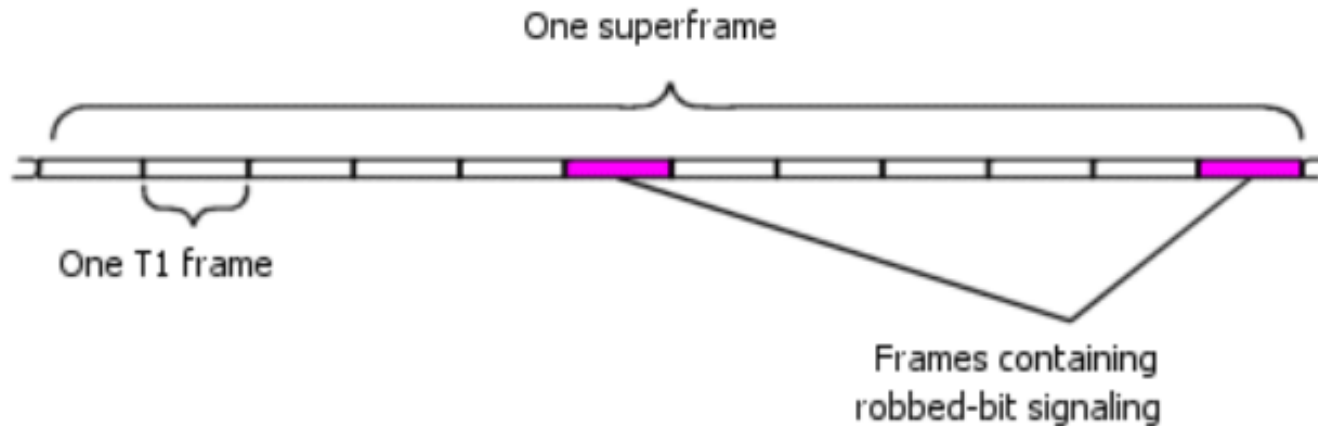

# Extended superframe

6 rámcový oddělovač (každý 4.)

6 CRC

12 diagnostika

-----

24

Navíc 4 bity zevnitř rámců ukradeny na signalizaci = > 16 možných zpráv

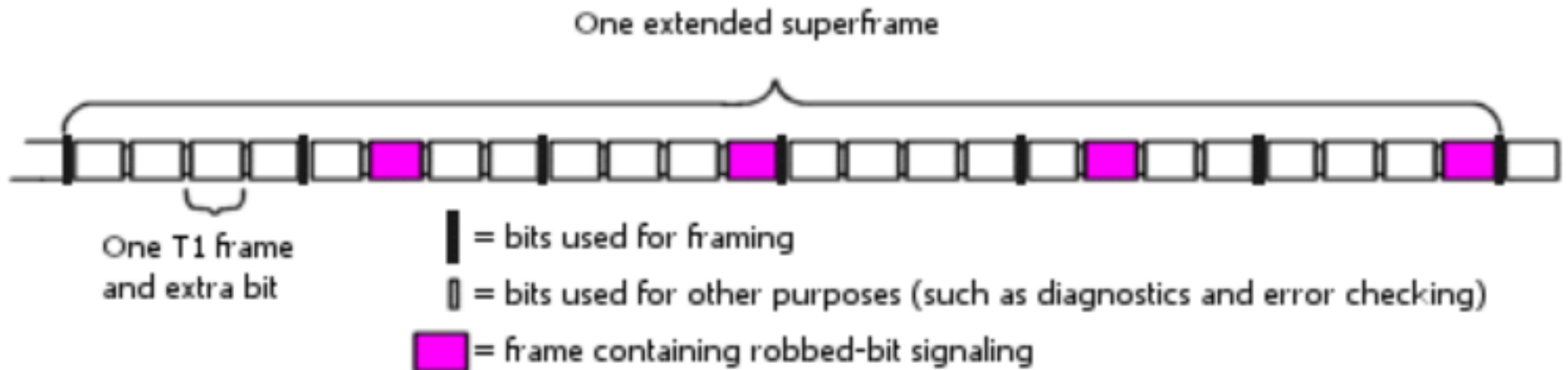

# Komunikace mezi dvěma ATA (Analog Telephone Adapter)

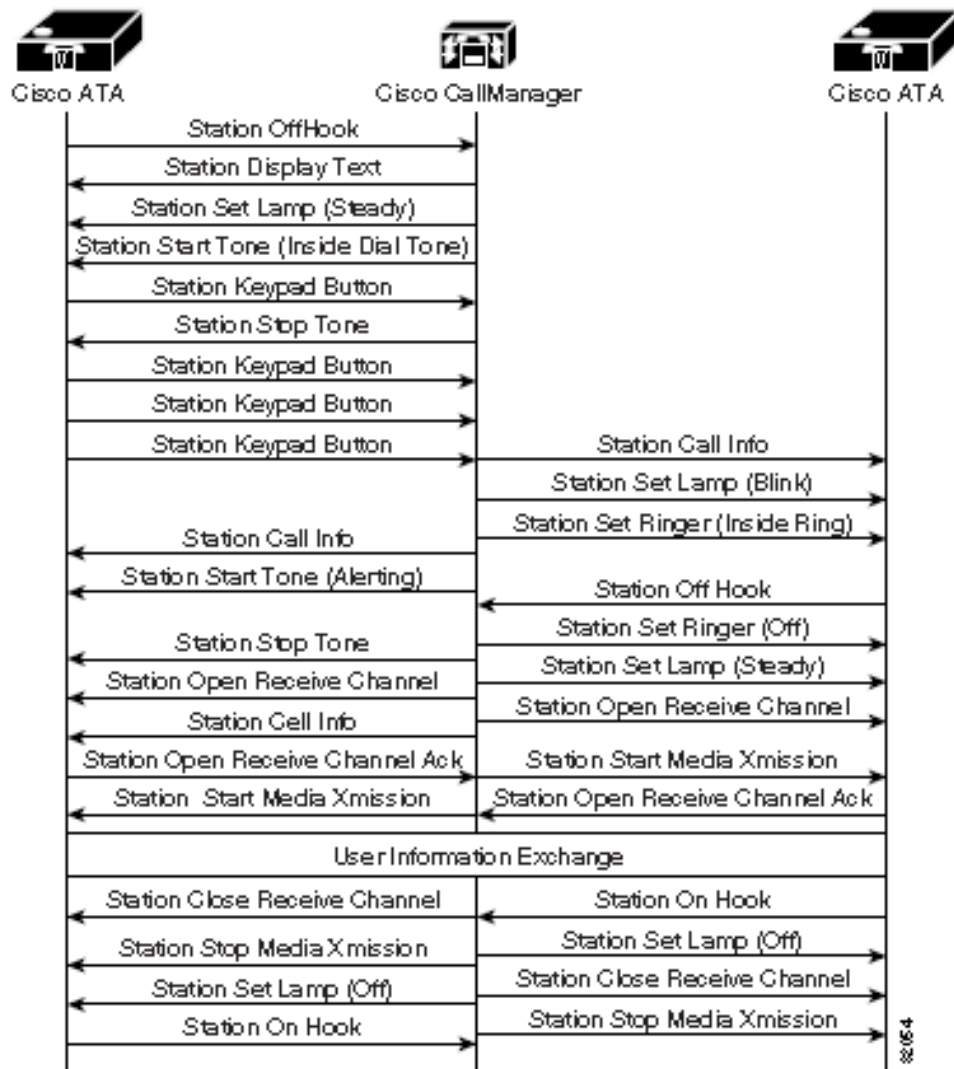

Cisco ATA 186 Analog  
Telephone Adapter w/  
**3,907.96 CZK**  
+408.07 CZK shipping



# Telefonování přes CCM

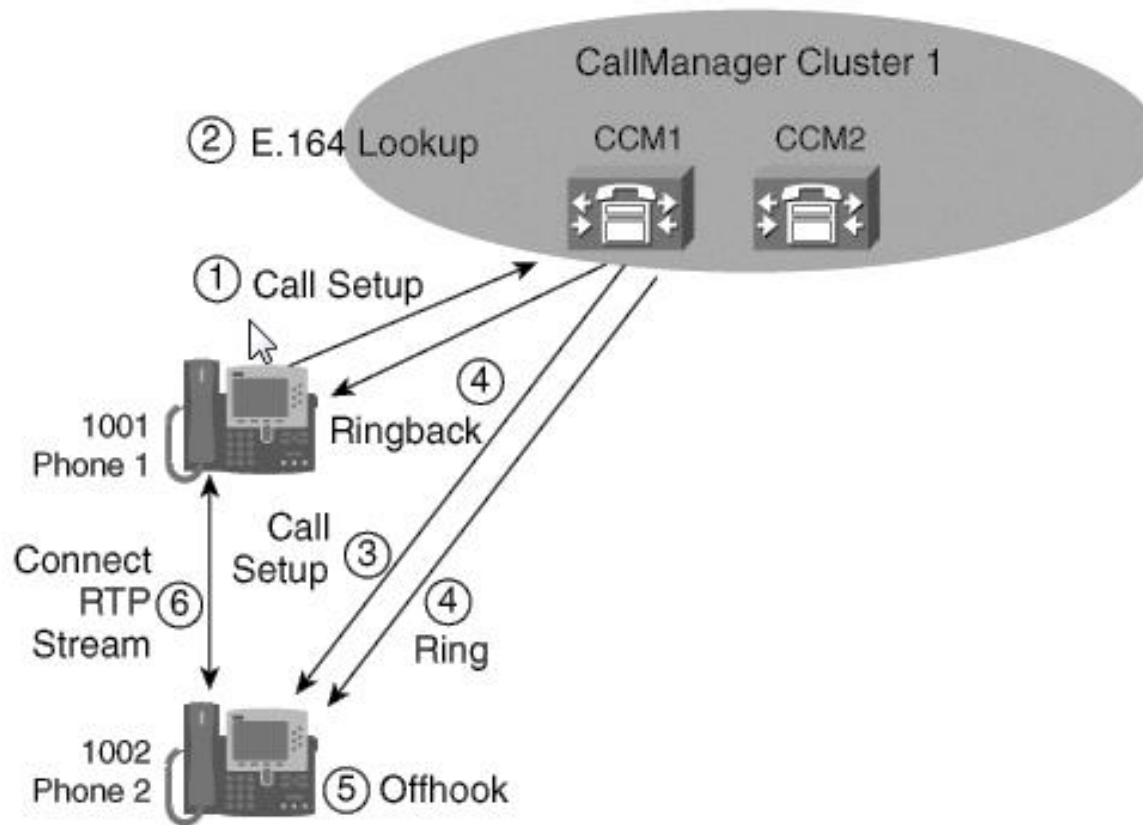

# Časový graf volání přes CCM

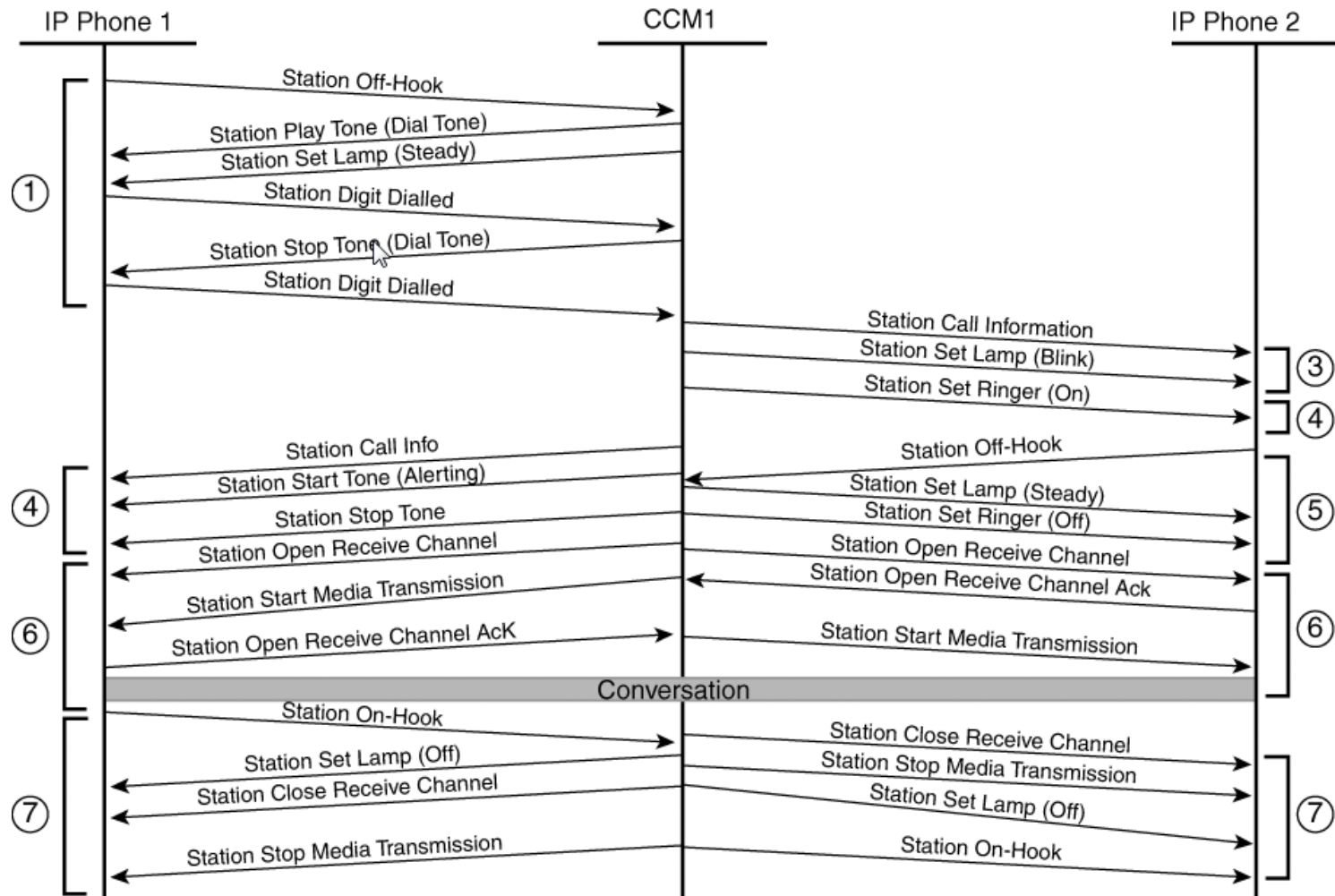

# Volání přes CCM uvnitř klastru

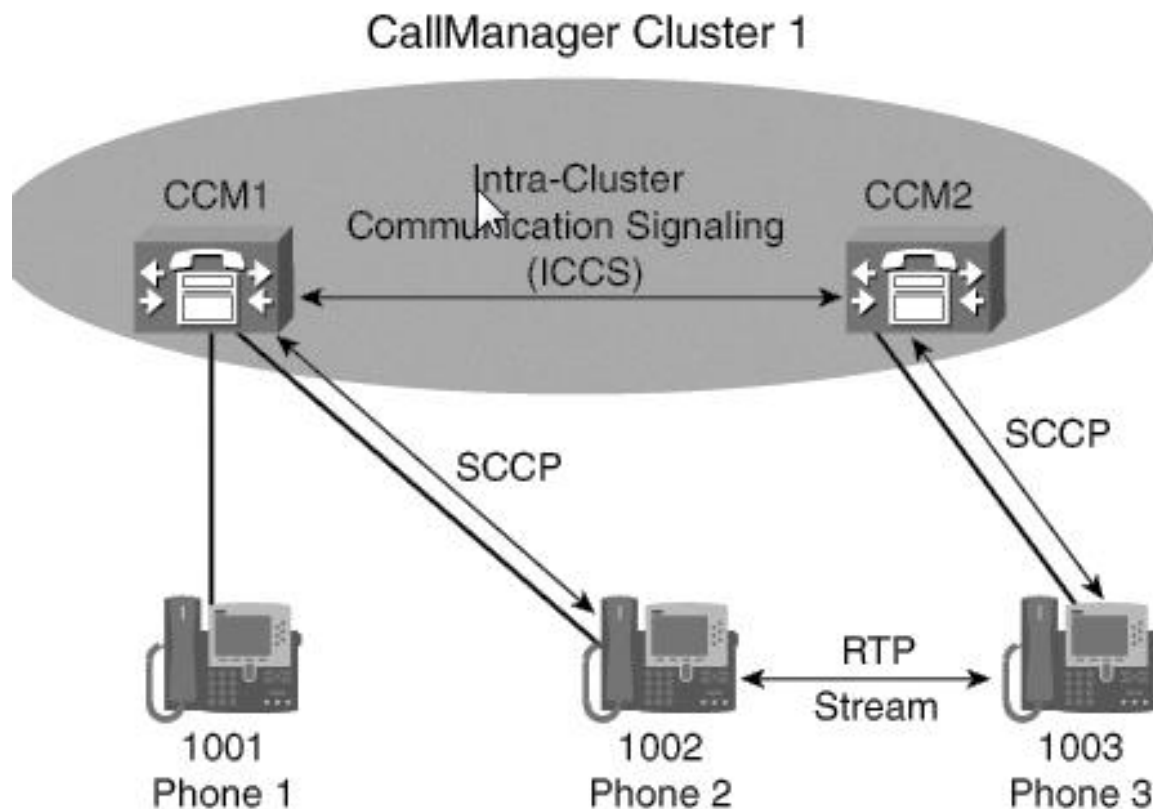

# Volání přes CCM v různých klastrech

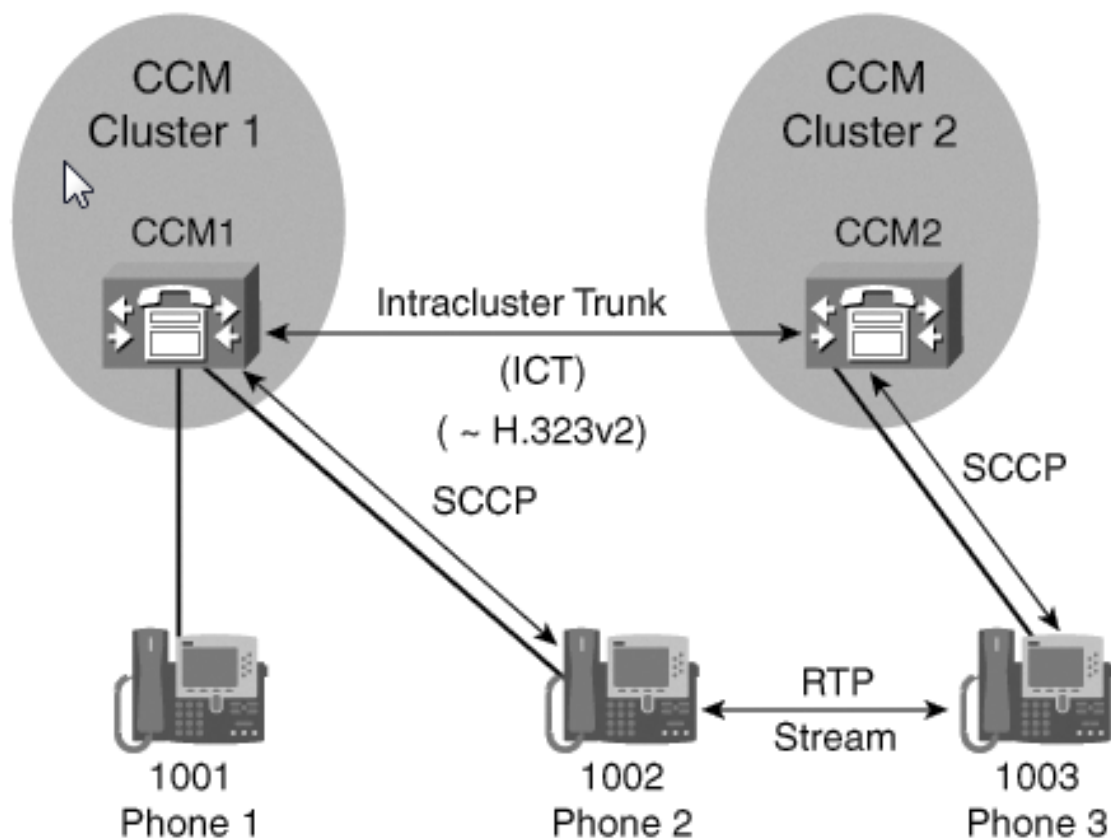

# Volání přes bránu

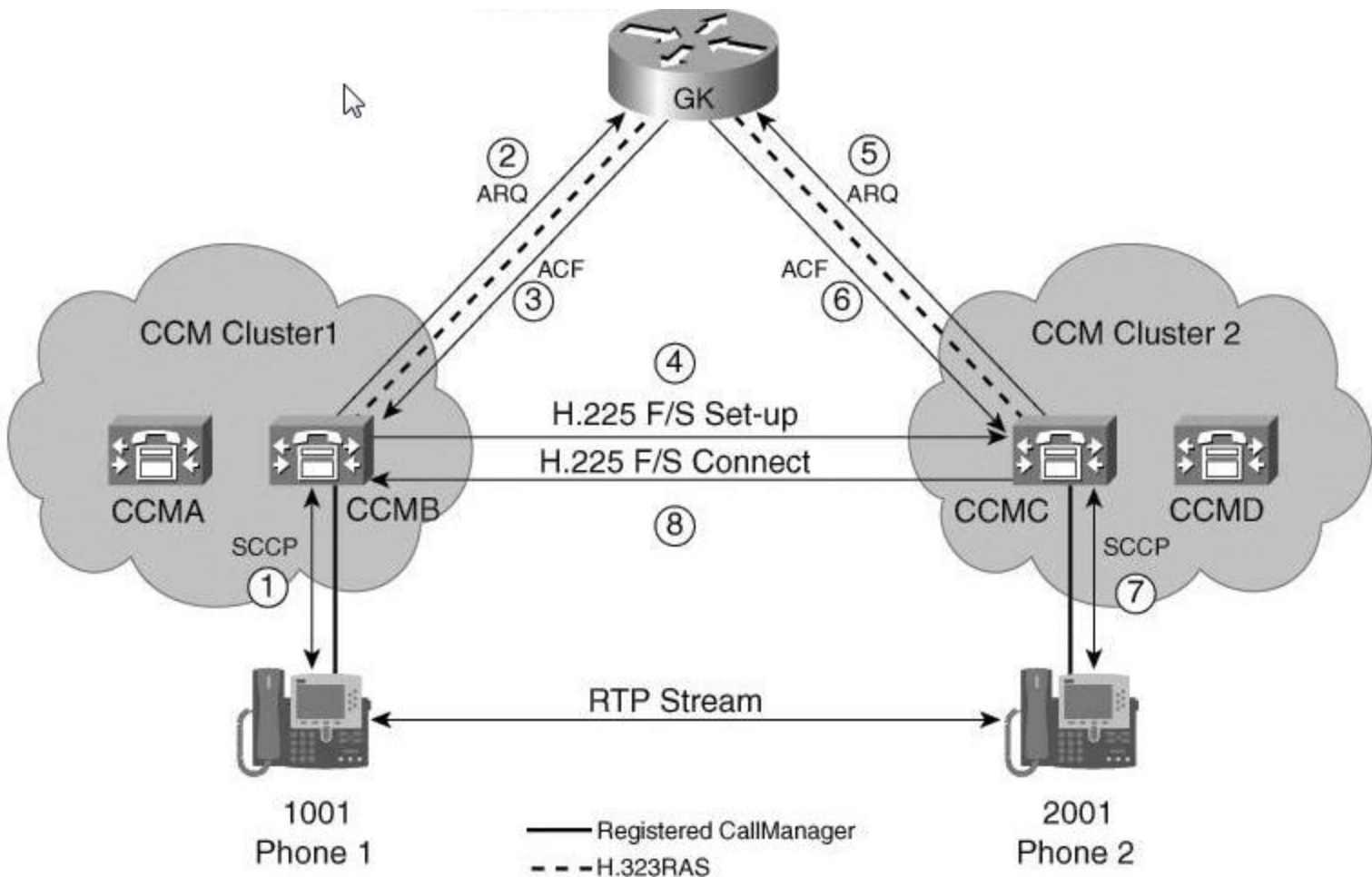

# Popis volání přes bránu

---

1. Endpoint A vytočí číslo 1123.
2. Endpoint pošle na Gatekeeper zprávu ARQ (Admission Request) protokolu RAS (Registration, Admission, Status).
3. Gatekeeper vrátí ACF (Admission Confirmation) s IP adresou koncového bodu B.
4. Endpoint A pošle zprávu Call Setup protokolu H.225 (Q.931) koncovému bodu B.
5. Endpoint B pošle Gatekeeperu zprávu ARQ, s dotazem, zda smí odpovědět na výzvu k hovoru.
6. Gatekeeper vrátí ACF s IP adresou Endpointu A.
7. Endpoint B odpovídá a posílá zprávu Connect protokolu H.225 (Q.931) Endpointu A.
8. Z obou koncových bodů je poslána Gatekeeperu zpráva IIR (InfoRequestResponse).
9. Některý z Endpointů rozpojí spojení zprávou DRQ (Disconnect Request) na Gatekeeper.
10. Gatekeeper pošle DCF (Disconnect Confirmation) na oba Endpointy.

# Test

---

1. Jaký je název VoIP společnosti, od které byl Skinny zakoupen Ciscem?
2. Jaké číslo TCP portu používá Skinny?
3. Pravda nebo lež: Skinny nepoužívá RTCP.
4. Pravda nebo lež: Všechny slyšitelné tóny jsou generovány z SCCP telefonů.
5. Pravda nebo lež: Všechny Skinny zprávy mají stejný formát záhlaví, měnící se dle typu kódu.
6. Pravda nebo lež: Adresa volání serveru přijde do telefonu prostřednictvím speciálního serveru DHCP.
7. Který Cisco příkaz zahajují konfiguraci umožňující komunikaci přes vícenásobné servery?
8. Které Skinny zprávy jsou odpovědné za stanovení použitých portů a za kodek?

- 
1. Jaký je název VoIP společnosti, od které byl Skinny zakoupen Ciscem? **Selsius.**
  2. Jaké číslo TCP portu používá Skinny? **2000**
  3. Pravda nebo lež: Skinny nepoužívá RTCP. **P**
  4. Pravda nebo lež: Všechny slyšené tóny jsou generovány z SCCP telefonů. **P**
  5. Pravda nebo lež: Všechny Skinny zprávy mají stejný formát záhlaví, měnící se dle typu kódu. **P**
  6. Pravda nebo lež: Adresa volání serveru přijde do telefonu prostřednictvím speciálního serveru DHCP. **L**
  7. Které Cisco příkazy umožňující komunikaci přes vícenásobné servery? **dial peer**
  8. Které Skinny zprávy jsou odpovědné za stanovení použitých portů a za kodek? **OpenReceiveChannel, OpenReceiveChannelACK, StartMediaTransmission**



# Zdroj na Internetu – ICOMM

The screenshot shows a web browser window with the URL <http://oneexamamonth.com/ICOMM.aspx>. The browser's address bar and toolbar are visible at the top. The website's header features a search bar with the text "Search the web" and a magnifying glass icon. Below the search bar is a banner image of network cables plugged into a wall outlet, with the text "1ExamAMonth.com Offering Resources for One Cisco® Exam Every Month". A navigation menu includes links for Home, CCNA, CCNP, CCNP Voice, Books, and Contact Us. The main content area is titled "CCNA Voice" and contains the following text:

The new CCNA Voice exam (ICOMM – Exam #: 640-461) was announced by Cisco on 10-19-10.

If an exam candidate already has their basic CCNA certification, they can earn the CCNA Voice Concentration by passing the single ICOMM exam.

Below this text is a section titled "Free Videos" which includes a video player. The video title is "ICOMM Lab 1 - Overview of ICOMM" and the video content includes the text "Introducing Cisco Voice and Unified Communications Administration (ICOMM) 8.0" and a list of topics:

- Call Flows
- Call Legs
- CUCM Call Flows

# Zdroj na Internetu – CVOICE

The screenshot shows a web browser window with the URL `http://oneexamamonth.com/cvoice.aspx`. The browser's address bar and search bar are visible. The website's main header features a search bar and the text "1ExamAMonth.com Offering Resources for One Cisco® Exam Every Month". Below the header is a navigation menu with tabs for "Home", "CCNA", "CCNP", "CCNP Voice", "Books", and "Contact Us".

On the left side, there is a vertical menu with the following items: "CVOICE", "CIPT", "QoS", "TUC", "TVOICE", and "CAPPS".

The main content area is titled "CVOICE Video Labs". Below this title, there is a text block that reads: "Check out a sample video from the CVOICE Video Labs product, which contains 14 labs targeting the new CVOICE 8.0 exam (642-437). Labs contained in the product include:". Below this text is a video player titled "CVOICE Video Labs Sample - CUCME Auto Regist". The video player shows a terminal window with the following commands and output:

```
Test Term Web 3.1 - COM2 V1
[BR2#]
BR2#
BR2#
BR2#
BR2#
BR2#
BR2#
BR2#
BR2#
BR2#
BR2#show ephone-dn summary
BR2#show ephone summary
BR2#conf term
Enter configuration commands, one per line. End with CTRL/Z.
BR2 (config)#telephony-service
BR2 (config-telephony)#max-ephones 5
BR2 (config-telephony)#max-dn 10
BR2 (config-telephony)#ip source-address 10.10.32.3
BR2 (config-telephony)#auto assign 1 to 2
BR2 (config-telephony)#
```

# Zdroje

---

## **Call Manager Express (CME) within Packet Tracer**

Ron Wellman

<https://www.youtube.com/watch?v=heli9ok4Hel>

## **Cisco basic CME config**

Bruce Hartpence

<https://www.youtube.com/watch?v=vZDpb5tM-ww&t=54s>

**Wiki Wireshark [http://wiki.wireshark.org/SampleCaptures#SIP\\_and\\_RTP](http://wiki.wireshark.org/SampleCaptures#SIP_and_RTP)**