

# Flowers Delivery

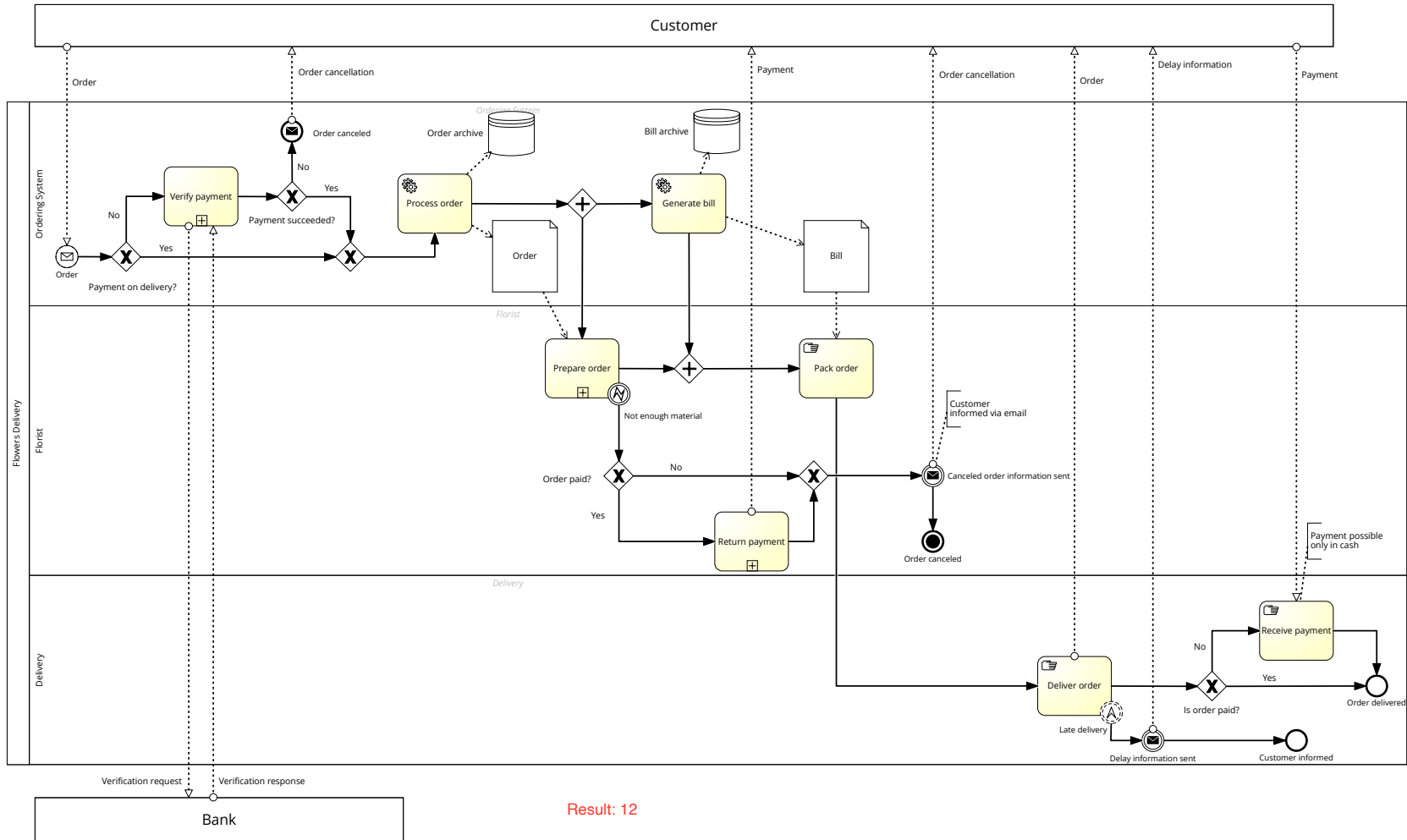

Result: 12

445504 Silvia Nagyová, group 01/CZECH

This diagram model Flowers's delivery system. Customers can place an order and choose from two payment methods: online card payment or payment on delivery. If chosen the online card payment method, the payment is verified. If the payment was successful or the customer will pay on delivery, the order is processed and bill generated. Florist then prepare and pack order, which is then delivered to the customer. If florist do not have enough material for order, customer is informed and order canceled with eventual payment return. If the order is late on delivery, the customer is informed about delay. If the order was not paid online by card, the customer pays for the order to the courier.