

# Schéma počítače (upravený model von Neumanna)

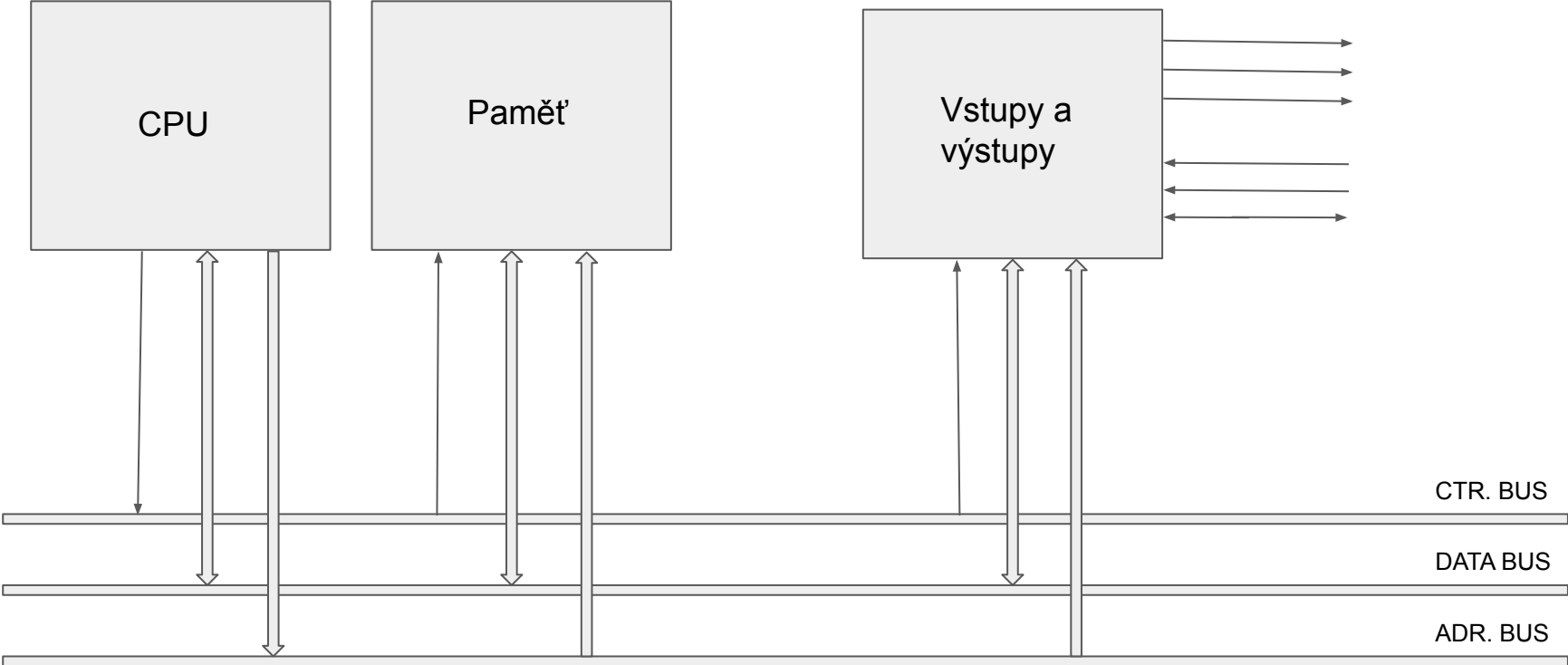

# CPU

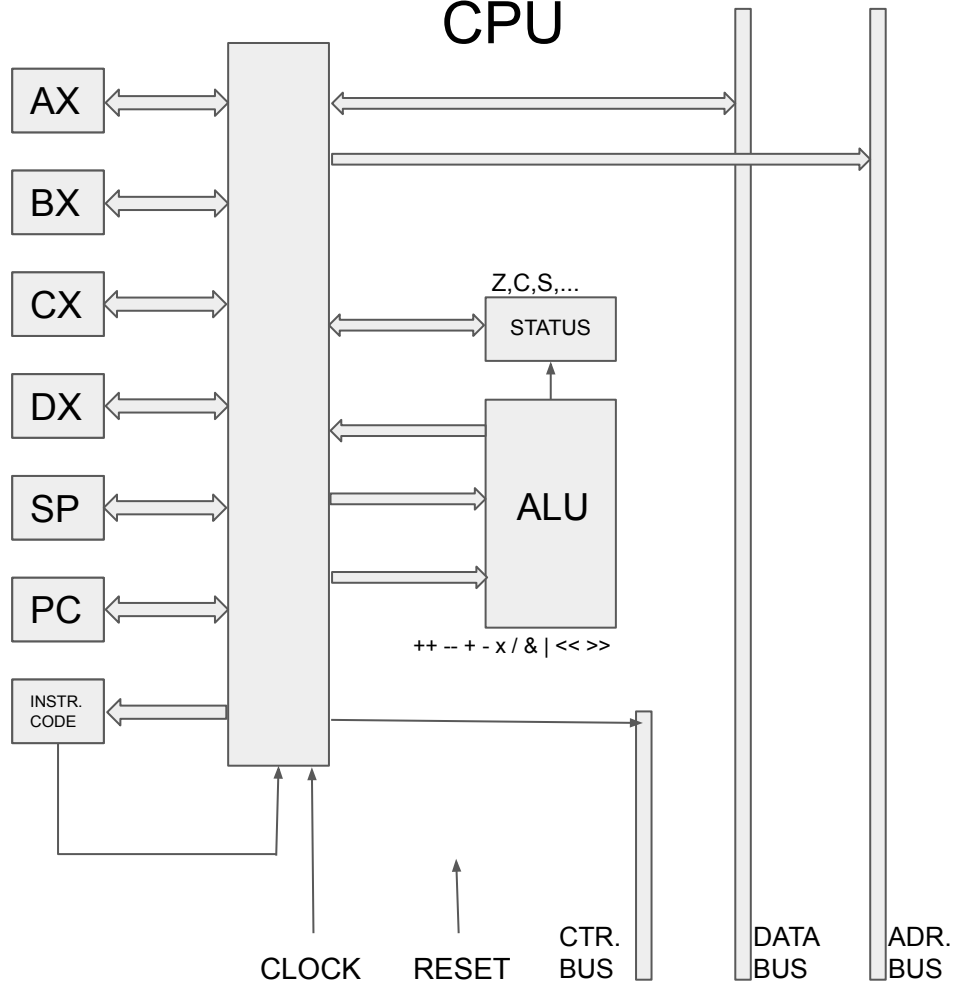

## Instrukce (minimální sada)

op2 registr, konstanta

op2 registr, registr

op2 registr, [adresa]

op2 registr, [ registr + konstanta]

op2 jsou: LOAD, STORE, ADD, SUB, CMP, ...

op1 registr

op1 [adresa]

op1 [ registr + konstanta]

op1 jsou: INC, DEC, CLEAR, ...

PUSH registr

POP registr

skok konstanta

skok registr

operace skoku jsou: JMP, CALL, JC, JNC, JZ, ...

RETURN

```

int main() {
int a;
int b;
char c[5 + 1];

...
a = fce(5 * 3, b);
...
}

```

```

main:
...
LOAD AX, [SP + 6]
PUSH AX
LOAD AX, 15
PUSH AX
CALL fce
ADD SP, 8
STORE AX, [SP + 10]
...

```

```

int fce(int p, int q) {
int r;
char s[10+1];

r = p + 10;
s[5] = p;
s[q + 1] = '\n';
return r;
}

```

```

fce:
ADD SP, -15
LOAD AX, [SP + 15 + 4 + 4]
ADD AX, 10
STORE AX, [SP + 11]
LOAD AX, [SP + 15 + 4 + 4]
STORE AL, [SP + 5]
LOAD BX, [SP + 15 + 4 + 0]
INC BX
ADD BX, SP
MOV AL, 10
STORE AL, [BX]
LOAD AX, [SP + 11]
ADD SP, 15
RETURN

```

SP →

část zásobníku obsazená  
předchozími funkcemi  
a (4 byte)  
b (4 byte)  
c (6 byte)

neobsazená část zásobníku

```

int main() {
int a;
int b;
char c[5 + 1];

...
a = fce(5 * 3, b);
...
}

```

```

main:
...
LOAD AX, [SP + 6]
PUSH AX
LOAD AX, 15
PUSH AX
CALL fce
ADD SP, 8
STORE AX, [SP + 10]
...

```

```

int fce(int p, int q) {
int r;
char s[10+1];

r = p + 10;
s[5] = p;
s[q + 1] = '\n';
return r;
}

```

```

fce:
ADD SP, -15
LOAD AX, [SP + 15 + 4 + 4]
ADD AX, 10
STORE AX, [SP + 11]
LOAD AX, [SP + 15 + 4 + 4]
STORE AL, [SP + 5]
LOAD BX, [SP + 15 + 4 + 0]
INC BX
ADD BX, SP
MOV AL, 10
STORE AL, [BX]
LOAD AX, [SP + 11]
ADD SP, 15
RETURN

```

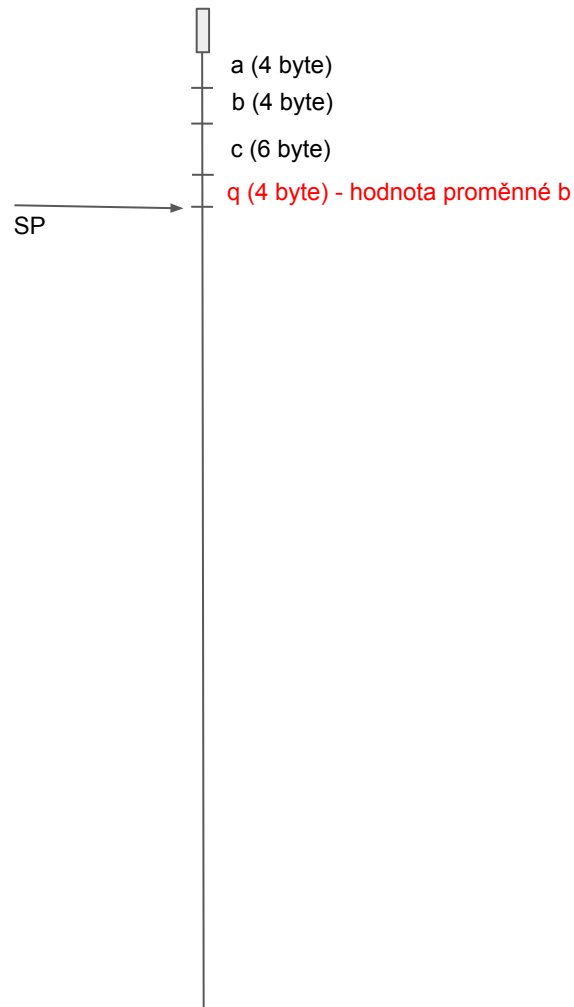

```

int main() {
int a;
int b;
char c[5 + 1];

...
a = fce(5 * 3, b);
...
}

```

```

main:
...
LOAD AX, [SP + 6]
PUSH AX
LOAD AX, 15
PUSH AX
CALL fce
ADD SP, 8
STORE AX, [SP + 10]
...

```

```

int fce(int p, int q) {
int r;
char s[10+1];

r = p + 10;
s[5] = p;
s[q + 1] = '\n';
return r;
}

```

```

fce:
ADD SP, -15
LOAD AX, [SP + 15 + 4 + 4]
ADD AX, 10
STORE AX, [SP + 11]
LOAD AX, [SP + 15 + 4 + 4]
STORE AL, [SP + 5]
LOAD BX, [SP + 15 + 4 + 0]
INC BX
ADD BX, SP
MOV AL, 10
STORE AL, [BX]
LOAD AX, [SP + 11]
ADD SP, 15
RETURN

```

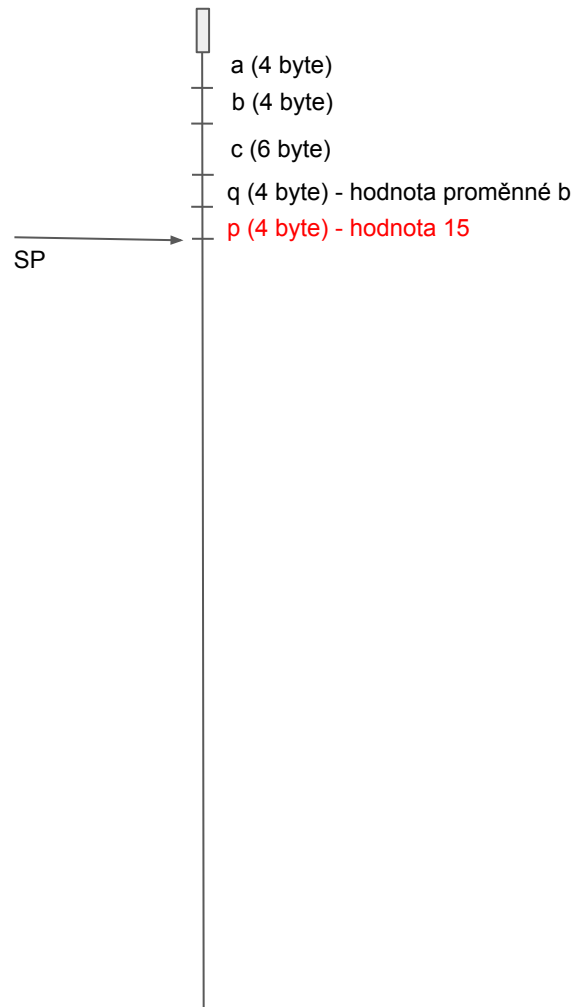

```

int main() {
int a;
int b;
char c[5 + 1];

...
a = fce(5 * 3, b);
...
}

```

```

main:
...
LOAD AX, [SP + 6]
PUSH AX
LOAD AX, 15
PUSH AX
CALL fce
ADD SP, 8
STORE AX, [SP + 10]
...

```

```

int fce(int p, int q) {
int r;
char s[10+1];

r = p + 10;
s[5] = p;
s[q + 1] = '\n';
return r;
}

```

```

fce:
ADD SP, -15
LOAD AX, [SP + 15 + 4 + 4]
ADD AX, 10
STORE AX, [SP + 11]
LOAD AX, [SP + 15 + 4 + 4]
STORE AL, [SP + 5]
LOAD BX, [SP + 15 + 4 + 0]
INC BX
ADD BX, SP
MOV AL, 10
STORE AL, [BX]
LOAD AX, [SP + 11]
ADD SP, 15
RETURN

```

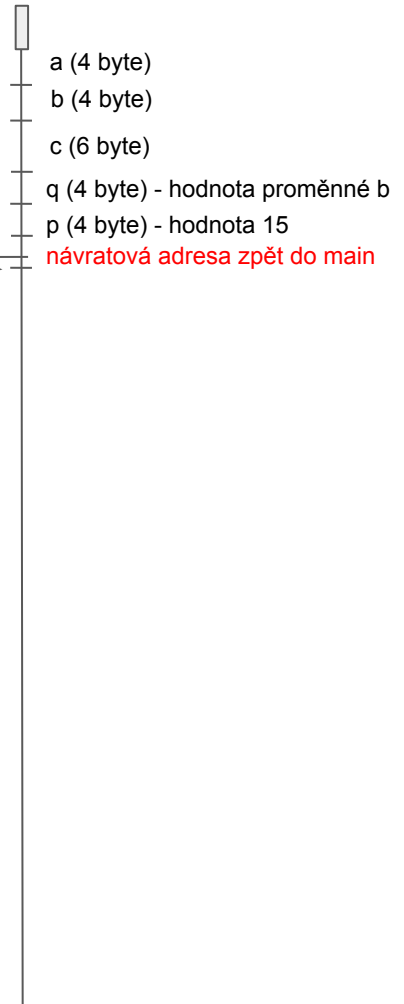

```

int main() {
int a;
int b;
char c[5 + 1];

...
a = fce(5 * 3, b);
...
}

```

```

main:
...
LOAD AX, [SP + 6]
PUSH AX
LOAD AX, 15
PUSH AX
CALL fce
ADD SP, 8
STORE AX, [SP + 10]
...

```

```

int fce(int p, int q) {
int r;
char s[10+1];

r = p + 10;
s[5] = p;
s[q + 1] = '\n';
return r;
}

```

```

fce:
ADD SP, -15
LOAD AX, [SP + 15 + 4 + 4]
ADD AX, 10
STORE AX, [SP + 11]
LOAD AX, [SP + 15 + 4 + 4]
STORE AL, [SP + 5]
LOAD BX, [SP + 15 + 4 + 0]
INC BX
ADD BX, SP
MOV AL, 10
STORE AL, [BX]
LOAD AX, [SP + 11]
ADD SP, 15
RETURN

```

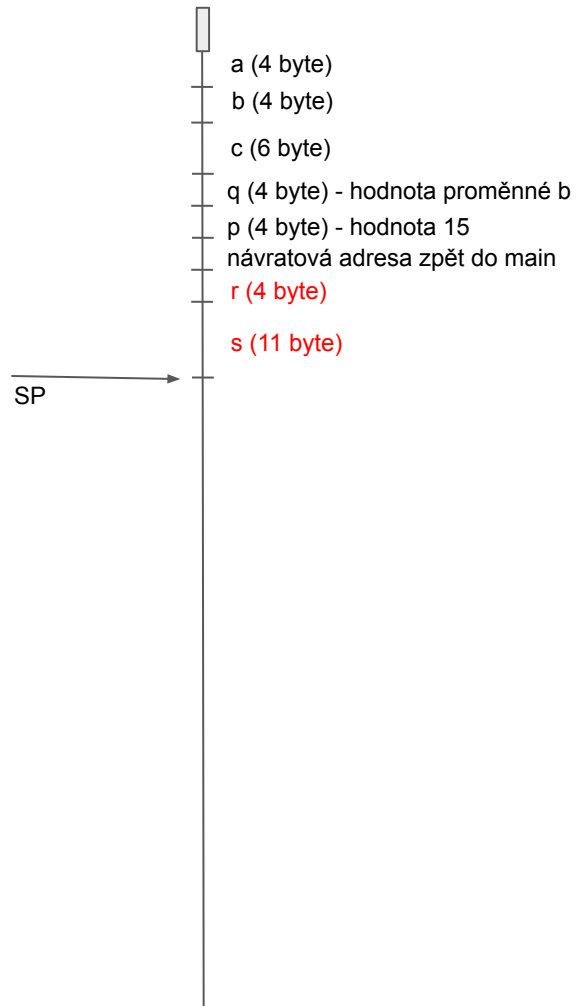

```

int main() {
int a;
int b;
char c[5 + 1];

...
a = fce(5 * 3, b);
...
}

```

```

main:
...
LOAD AX, [SP + 6]
PUSH AX
LOAD AX, 15
PUSH AX
CALL fce
ADD SP, 8
STORE AX, [SP + 10]
...

```

```

int fce(int p, int q) {
int r;
char s[10+1];

r = p + 10;
s[5] = p;
s[q + 1] = '\n';
return r;
}

```

```

fce:
ADD SP, -15
LOAD AX, [SP + 15 + 4 + 4]
ADD AX, 10
STORE AX, [SP + 11]
LOAD AX, [SP + 15 + 4 + 4]
STORE AL, [SP + 5]
LOAD BX, [SP + 15 + 4 + 0]
INC BX
ADD BX, SP
MOV AL, 10
STORE AL, [BX]
LOAD AX, [SP + 11]
ADD SP, 15
RETURN

```

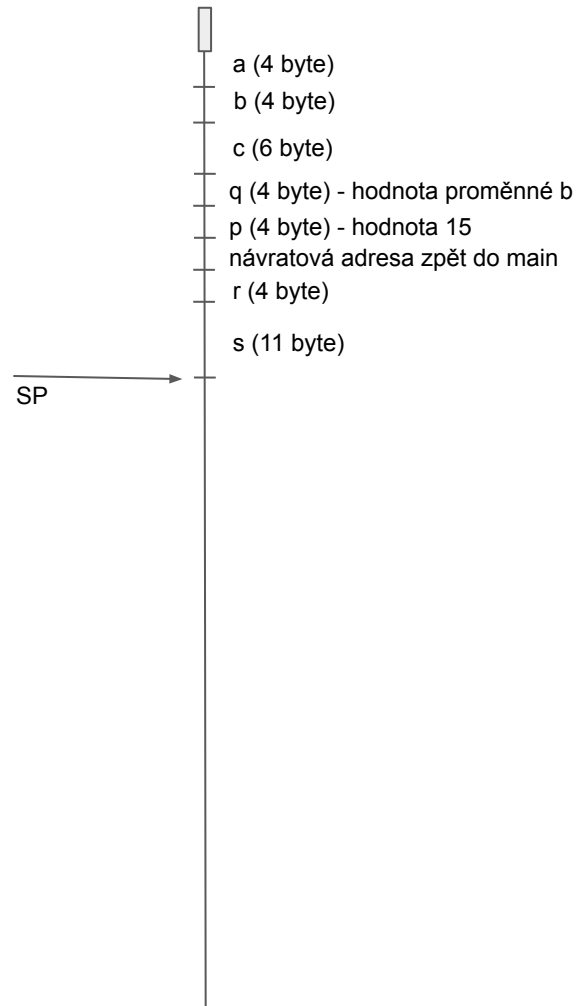



```

int main() {
int a;
int b;
char c[5 + 1];

...
a = fce(5 * 3, b);
...
}

```

```

main:
...
LOAD AX, [SP + 6]
PUSH AX
LOAD AX, 15
PUSH AX
CALL fce
ADD SP, 8
STORE AX, [SP + 10]
...

```

```

int fce(int p, int q) {
int r;
char s[10+1];

r = p + 10;
s[5] = p;
s[q + 1] = '\n';
return r;
}

```

```

fce:
ADD SP, -15
LOAD AX, [SP + 15 + 4 + 4]
ADD AX, 10
STORE AX, [SP + 11]
LOAD AX, [SP + 15 + 4 + 4]
STORE AL, [SP + 5]
LOAD BX, [SP + 15 + 4 + 0]
INC BX
ADD BX, SP
MOV AL, 10
STORE AL, [BX]
LOAD AX, [SP + 11]
ADD SP, 15
RETURN

```

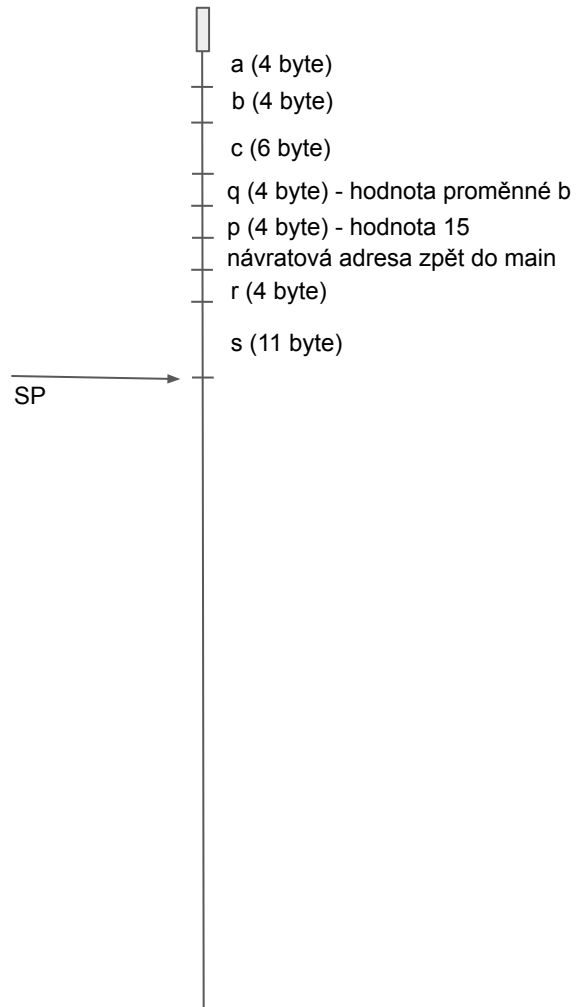

```

int main() {
int a;
int b;
char c[5 + 1];

...
a = fce(5 * 3, b);
...
}

```

```

main:
...
LOAD AX, [SP + 6]
PUSH AX
LOAD AX, 15
PUSH AX
CALL fce
ADD SP, 8
STORE AX, [SP + 10]
...

```

```

int fce(int p, int q) {
int r;
char s[10+1];

r = p + 10;
s[5] = p;
s[q + 1] = '\n';
return r;
}

```

```

fce:
ADD SP, -15
LOAD AX, [SP + 15 + 4 + 4]
ADD AX, 10
STORE AX, [SP + 11]
LOAD AX, [SP + 15 + 4 + 4]
STORE AL, [SP + 5]
LOAD BX, [SP + 15 + 4 + 0]
INC BX
ADD BX, SP
MOV AL, 10
STORE AL, [BX]
LOAD AX, [SP + 11]
ADD SP, 15
RETURN

```

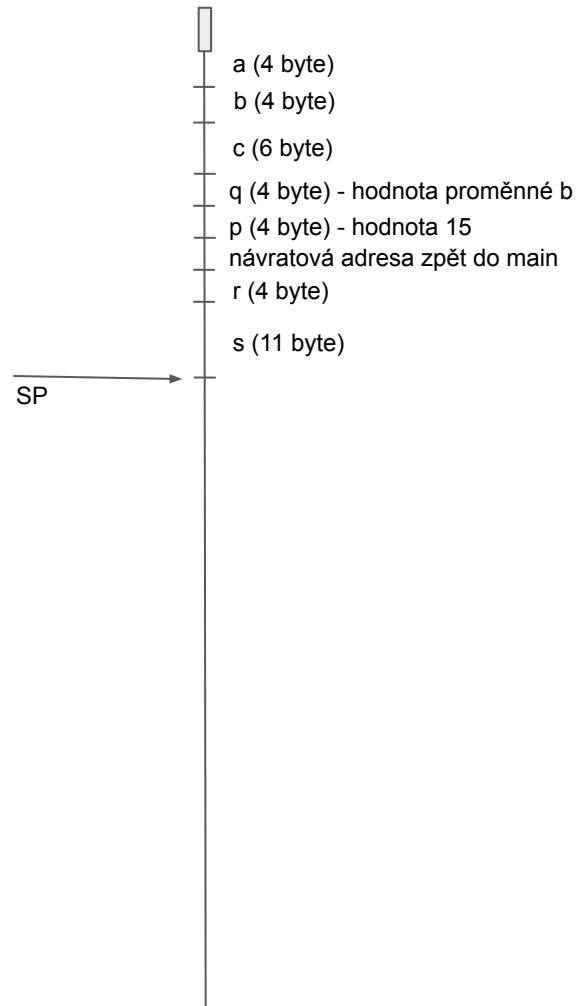

```

int main() {
int a;
int b;
char c[5 + 1];

...
a = fce(5 * 3, b);
...
}

```

```

main:
...
LOAD AX, [SP + 6]
PUSH AX
LOAD AX, 15
PUSH AX
CALL fce
ADD SP, 8
STORE AX, [SP + 10]
...

```

```

int fce(int p, int q) {
int r;
char s[10+1];

r = p + 10;
s[5] = p;
s[q + 1] = '\n';
return r;
}

```

```

fce:
ADD SP, -15
LOAD AX, [SP + 15 + 4 + 4]
ADD AX, 10
STORE AX, [SP + 11]
LOAD AX, [SP + 15 + 4 + 4]
STORE AL, [SP + 5]
LOAD BX, [SP + 15 + 4 + 0]
INC BX
ADD BX, SP
MOV AL, 10
STORE AL, [BX]
LOAD AX, [SP + 11]
ADD SP, 15
RETURN

```

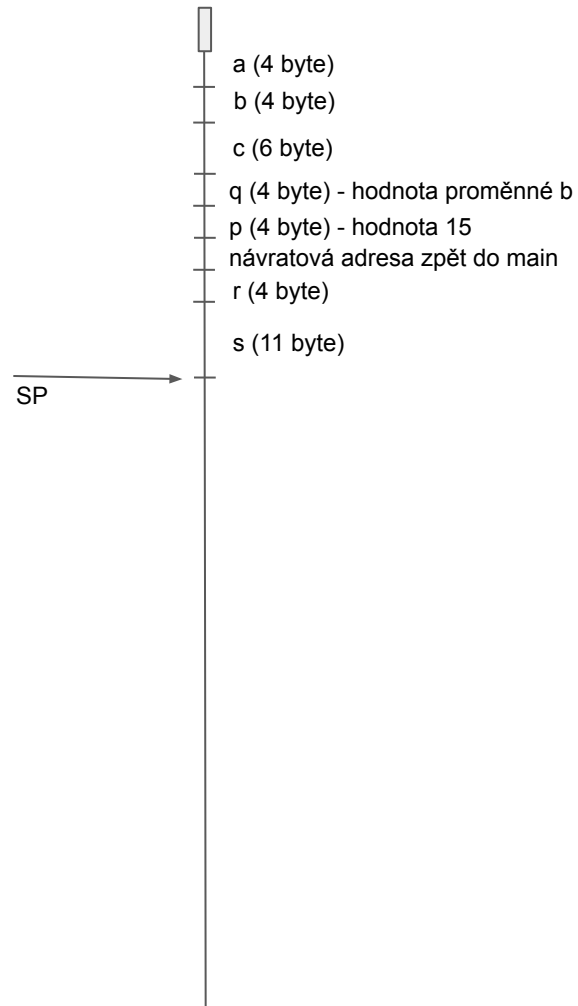

```

int main() {
int a;
int b;
char c[5 + 1];

...
a = fce(5 * 3, b);
...
}

```

```

main:
...
LOAD AX, [SP + 6]
PUSH AX
LOAD AX, 15
PUSH AX
CALL fce
ADD SP, 8
STORE AX, [SP + 10]
...

```

```

int fce(int p, int q) {
int r;
char s[10+1];

r = p + 10;
s[5] = p;
s[q + 1] = '\n';
return r;
}

```

```

fce:
ADD SP, -15
LOAD AX, [SP + 15 + 4 + 4]
ADD AX, 10
STORE AX, [SP + 11]
LOAD AX, [SP + 15 + 4 + 4]
STORE AL, [SP + 5]
LOAD BX, [SP + 15 + 4 + 0]
INC BX
ADD BX, SP
MOV AL, 10
STORE AL, [BX]
LOAD AX, [SP + 11]
ADD SP, 15
RETURN

```

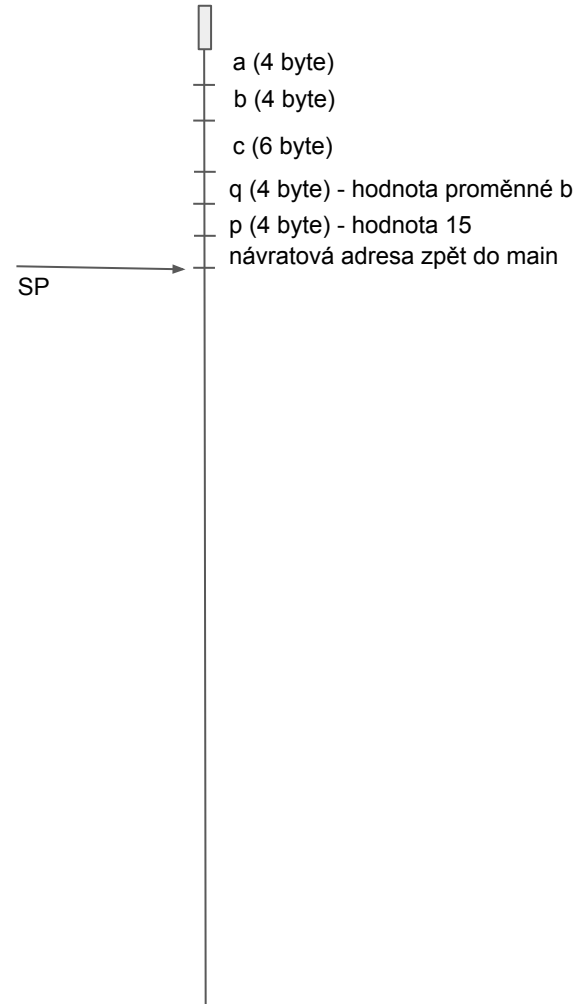

```

int main() {
int a;
int b;
char c[5 + 1];

...
a = fce(5 * 3, b);
...
}

```

```

main:
...
LOAD AX, [SP + 6]
PUSH AX
LOAD AX, 15
PUSH AX
CALL fce
ADD SP, 8
STORE AX, [SP + 10]
...

```

```

int fce(int p, int q) {
int r;
char s[10+1];

r = p + 10;
s[5] = p;
s[q + 1] = '\n';
return r;
}

```

```

fce:
ADD SP, -15
LOAD AX, [SP + 15 + 4 + 4]
ADD AX, 10
STORE AX, [SP + 11]
LOAD AX, [SP + 15 + 4 + 4]
STORE AL, [SP + 5]
LOAD BX, [SP + 15 + 4 + 0]
INC BX
ADD BX, SP
MOV AL, 10
STORE AL, [BX]
LOAD AX, [SP + 11]
ADD SP, 15
RETURN

```

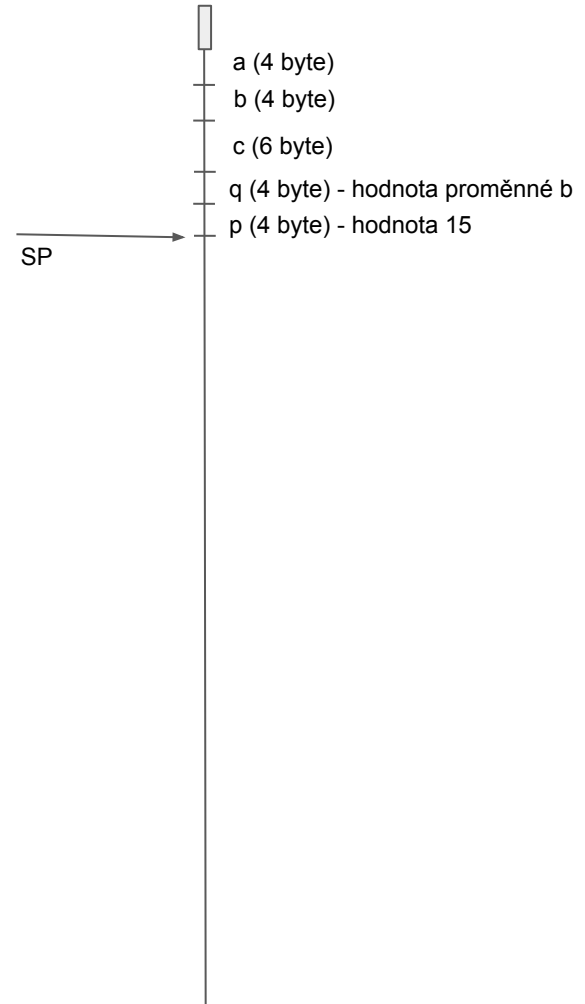

```

int main() {
int a;
int b;
char c[5 + 1];

...
a = fce(5 * 3, b);
...
}

```

```

main:
...
LOAD AX, [SP + 6]
PUSH AX
LOAD AX, 15
PUSH AX
CALL fce
ADD SP, 8
STORE AX, [SP + 10]
...

```

```

int fce(int p, int q) {
int r;
char s[10+1];

r = p + 10;
s[5] = p;
s[q + 1] = '\n';
return r;
}

```

```

fce:
ADD SP, -15
LOAD AX, [SP + 15 + 4 + 4]
ADD AX, 10
STORE AX, [SP + 11]
LOAD AX, [SP + 15 + 4 + 4]
STORE AL, [SP + 5]
LOAD BX, [SP + 15 + 4 + 0]
INC BX
ADD BX, SP
MOV AL, 10
STORE AL, [BX]
LOAD AX, [SP + 11]
ADD SP, 15
RETURN

```

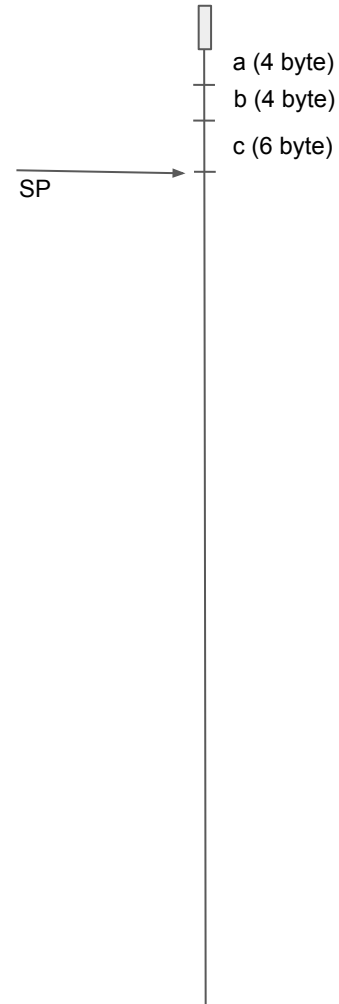

```

int main() {
int a;
int b;
char c[5 + 1];

...
a = fce(5 * 3, b);
...
}

```

```

int fce(int p, int q) {
int r;
char s[10+1];

r = p + 10;
s[5] = p;
s[q + 1] = '\n';
return r;
}

```

```

main:
...
LOAD AX, [SP + 6]
PUSH AX
LOAD AX, 15
PUSH AX
CALL fce
ADD SP, 8
STORE AX, [SP + 10]
...

```

```

fce:
ADD SP, -15
LOAD AX, [SP + 15 + 4 + 4]
ADD AX, 10
STORE AX, [SP + 11]
LOAD AX, [SP + 15 + 4 + 4]
STORE AL, [SP + 5]
LOAD BX, [SP + 15 + 4 + 0]
INC BX
ADD BX, SP
MOV AL, 10
STORE AL, [BX]
LOAD AX, [SP + 11]
ADD SP, 15
RETURN

```

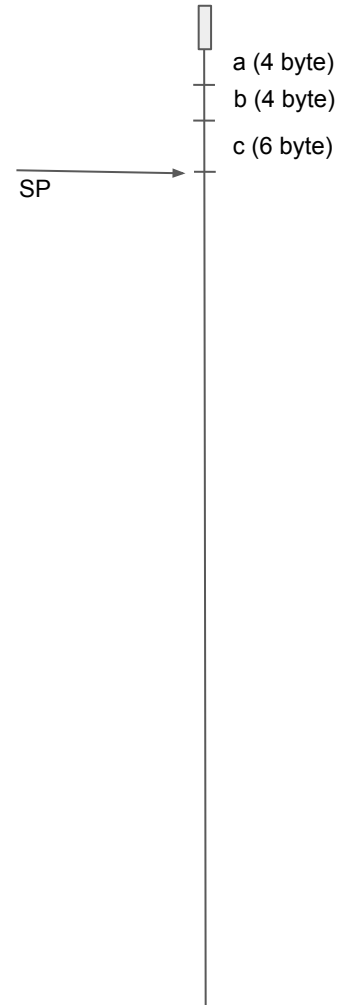

Zpřístupnění dat



## Lokální proměnná

```
int r;
```

```
LOAD AX, [SP + k]
```

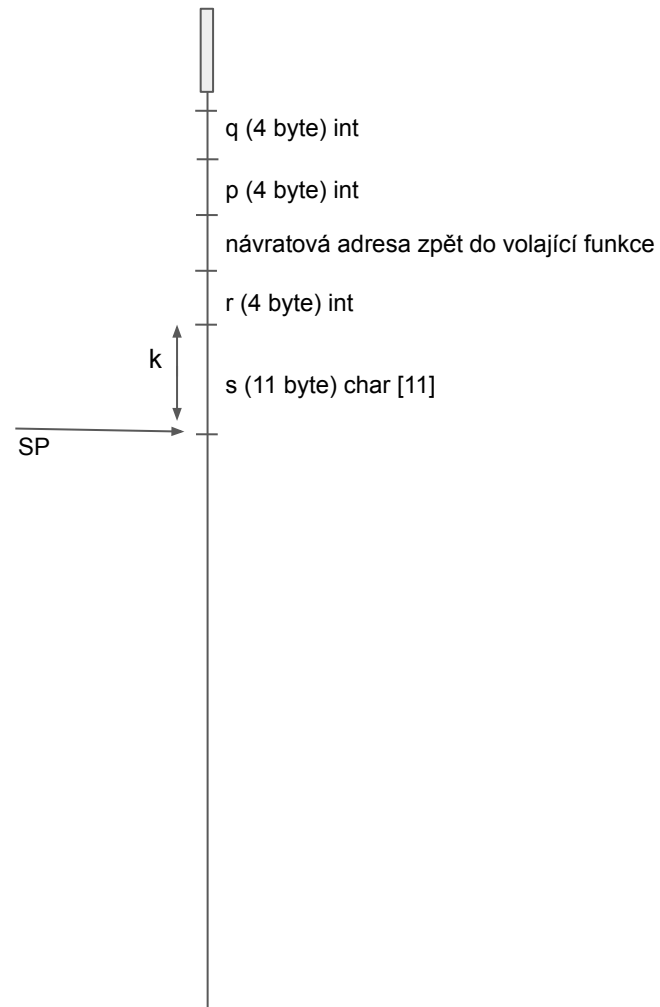

## Parametr

```
void fce(int p, int q)
```

```
LOAD AX, [SP + k]
```

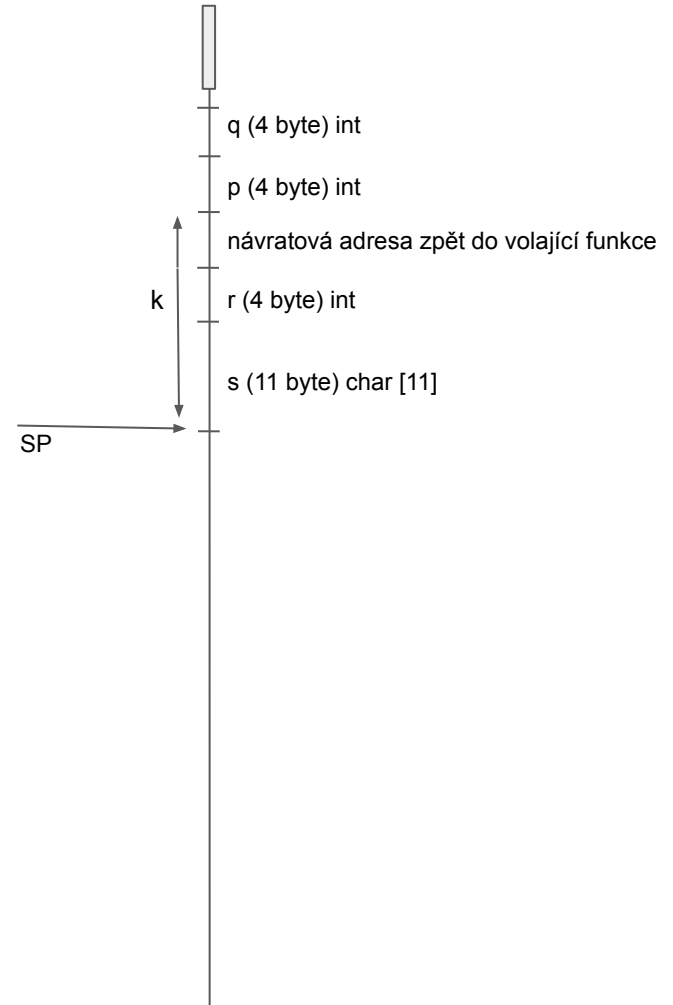

## Reference přes pointer

```
int * r = &q;
```

```
*r
```

```
LOAD BX, [SP + k]
```

```
LOAD AX, [BX]
```

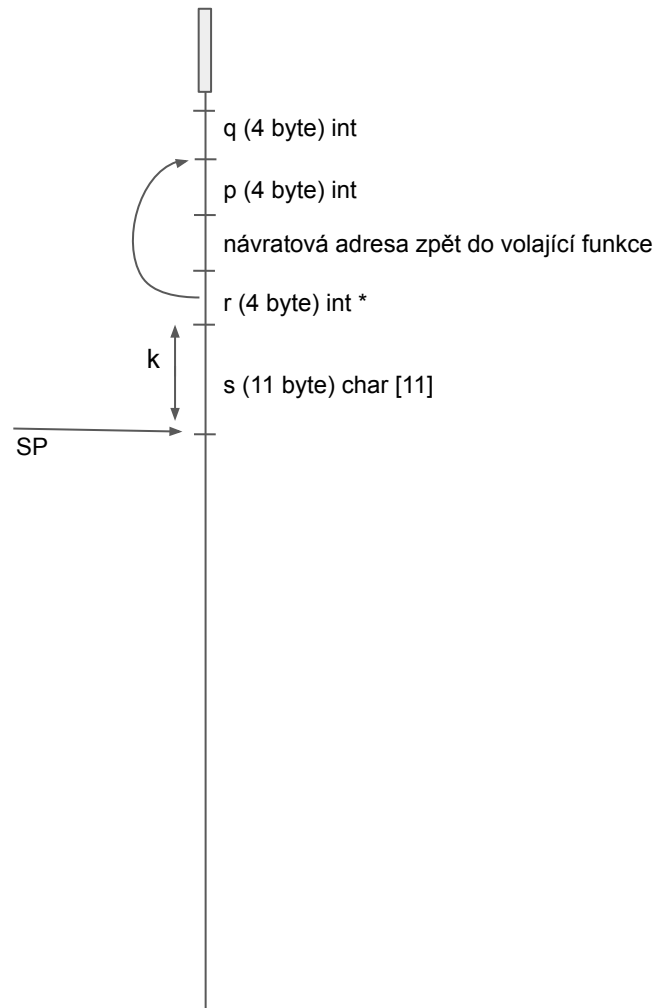

## Atribut třídy, prvek struktury (jako lokální proměnná)

```
struct x {  
    int r;  
    char s[10+1];  
} o;  
  
LOAD AX, [SP + (k1 + k2)]
```

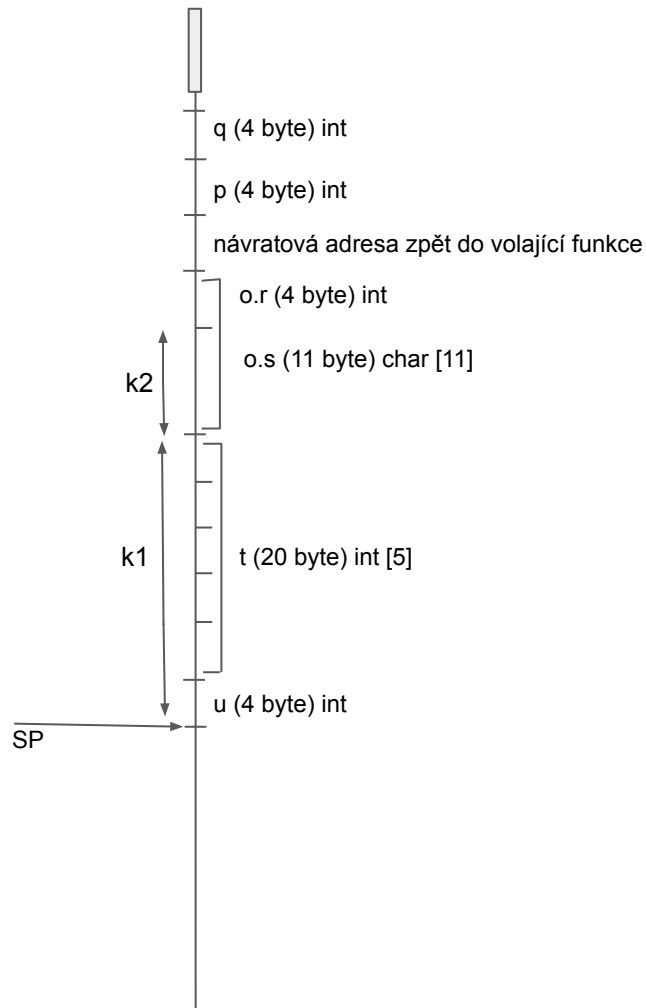

Prvek pole s konstantním indexem  
(jako lokální proměnná)

`t[3]`

```
LOAD AX, [SP + (k1 + 3*4)]
```

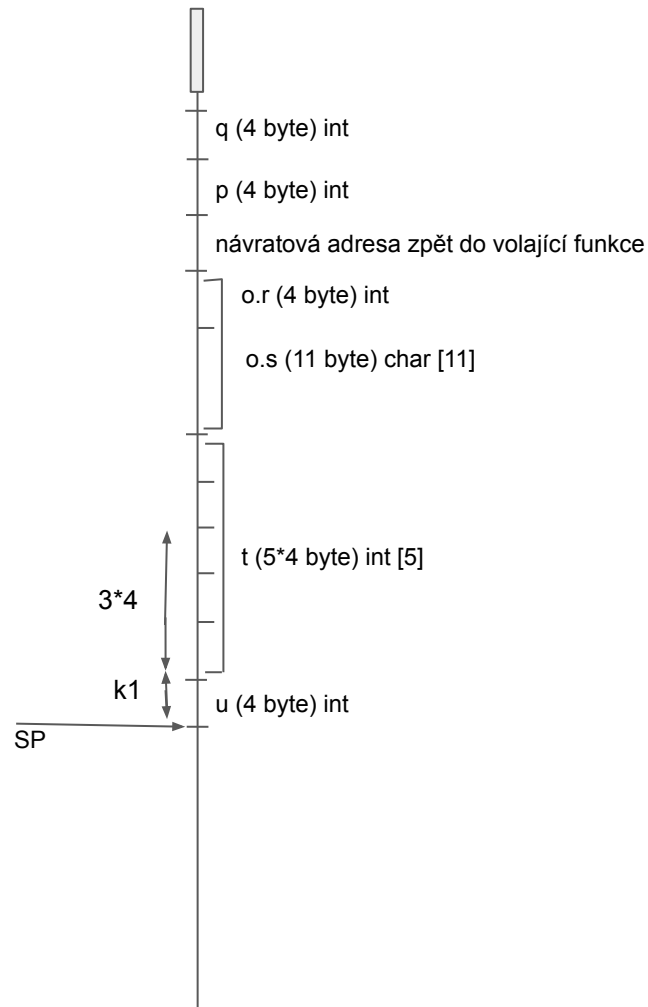

## Prvek pole s nekonstantním indexem (jako lokální proměnná)

```
int p = 3
```

```
t[p]
```

```
LOAD BX, [SP + k2]  
MUL BX, k3          k3 = sizeof(int)  
ADD BX, k1  
LOAD AX, [SP + BX]
```

alternativně poslední instrukce:

```
ADD BX, SP  
LOAD AX, [BX]
```

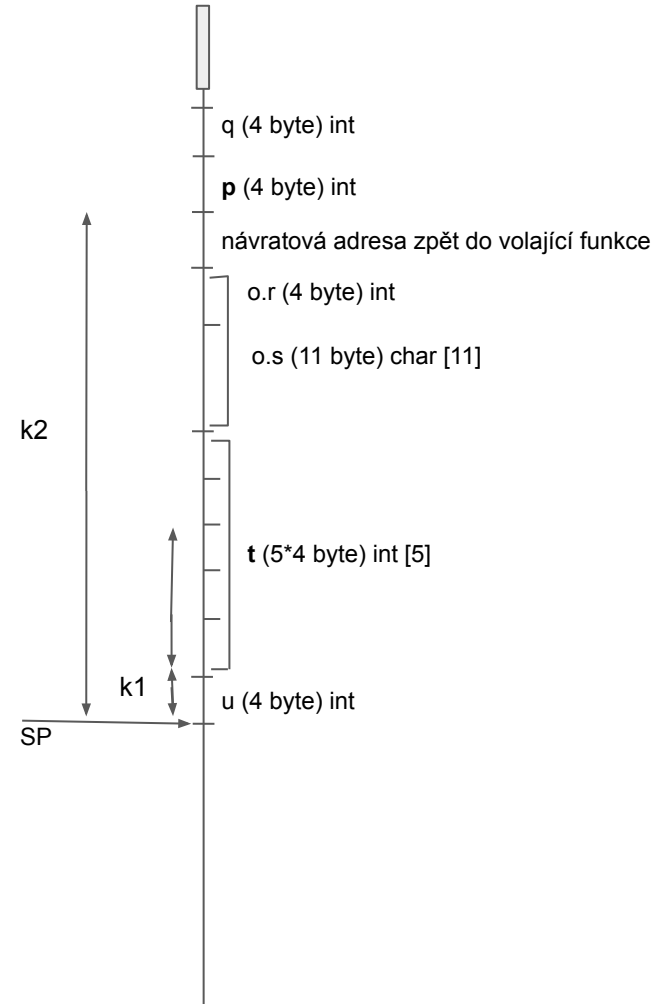

## Prvek pole s nekonstantním indexem (na haldě)

```
int * q  
int p = 3  
q[p]
```

```
LOAD BX, [SP + k2]  
MUL BX, k3          k3 = sizeof(int)  
ADD BX, [SP + k1]  
LOAD AX, [SP + BX]
```

```
alternativně poslední instrukce:  
ADD BX, SP  
LOAD AX, [BX]
```

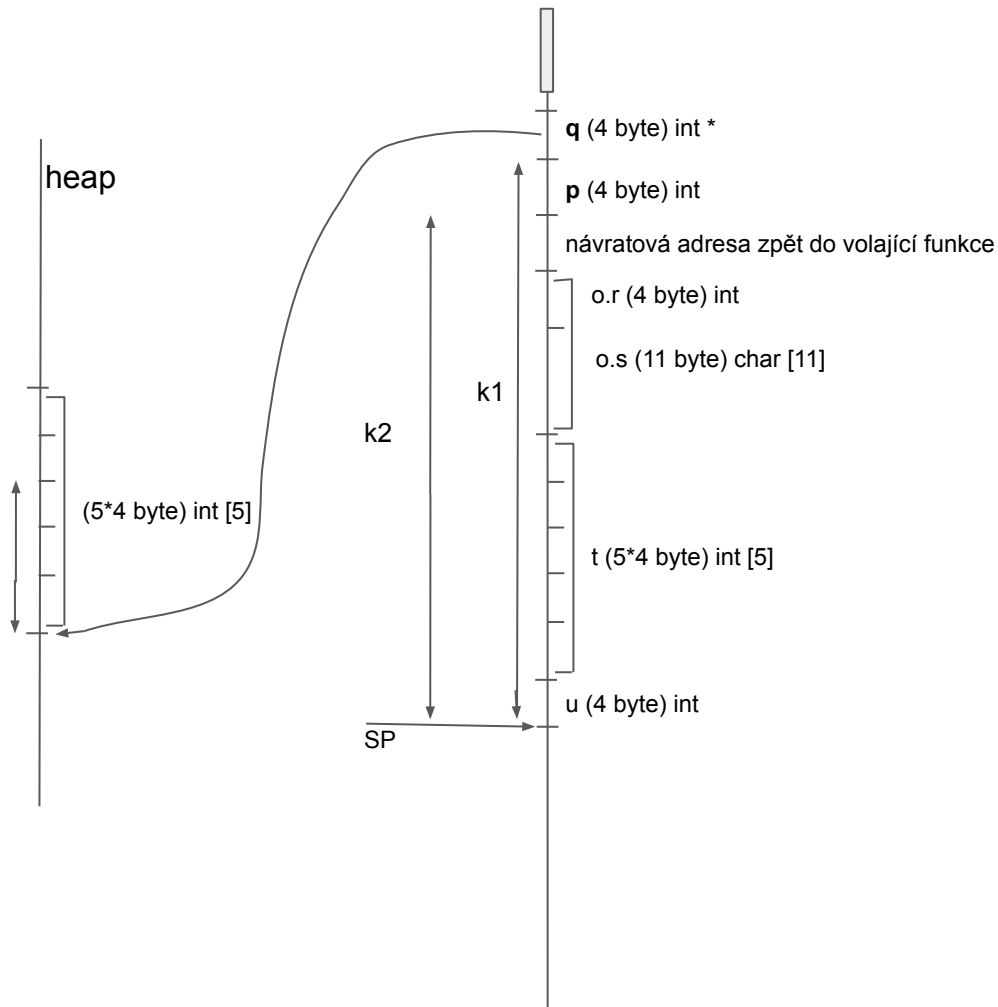

## Atribut třídy, prvek struktury (na haldě)

```
struct x {  
    int r;  
    char s[10+1];  
} o;
```

**q.r**

```
LOAD BX, [SP + k1]  
ADD BX, k2  
LOAD AX, [BX]
```

