

architektura

1. z hlediska funkce (samostatnost)

1. z hlediska stylu

1. z hlediska objektivit

produkce místo reprodukce

Vitruvius
(kol. 80/70 – po 15 př. n. l.)

De architectura libri X

- firmitas (pevnost, statika)
- utilitas (účelnost / účel)
- venustas (krása, proporčnost)

Leone Battista Alberti
(1404–1472)

De re aedificatoria libri X

1. architekt v dnešním slova smyslu

Adolf Loos
(1870–1933)

Ornament und Verbrechen

□ rmitas + utilitas = venustas



Adolf Loos

Obchodní dům
Goldman
& Salatsch,
Viedeň

1910–1911

□ rmitas < utilitas → funkcionalismus

utilitas < □ rmitas → konstruktivismus

celek → jednotlivosti

důležité → méně důležité

spodní → horní



Lord Burlington: Chiswick House (1725–1729)



Notre-Dame, Laon (1160–1225)

funkce

vnější prostor (umístění, poloha)

vnější hmota

půdorys

vnitřní prostor

vnitřní hmota

světlo

barva

funkce

architektura sakrální (církevní)

architektura civilní (světská)

architektura forti□kační (vojenská)

architektura voluptární (rekreační)

architektura sakrální

I. typ

podélný typ

(biskupské, farní a klášterní kostely)

síňový x halový x bazilikální

centrální typ

(baptisteria, martyria, memoriální kaple atd.)

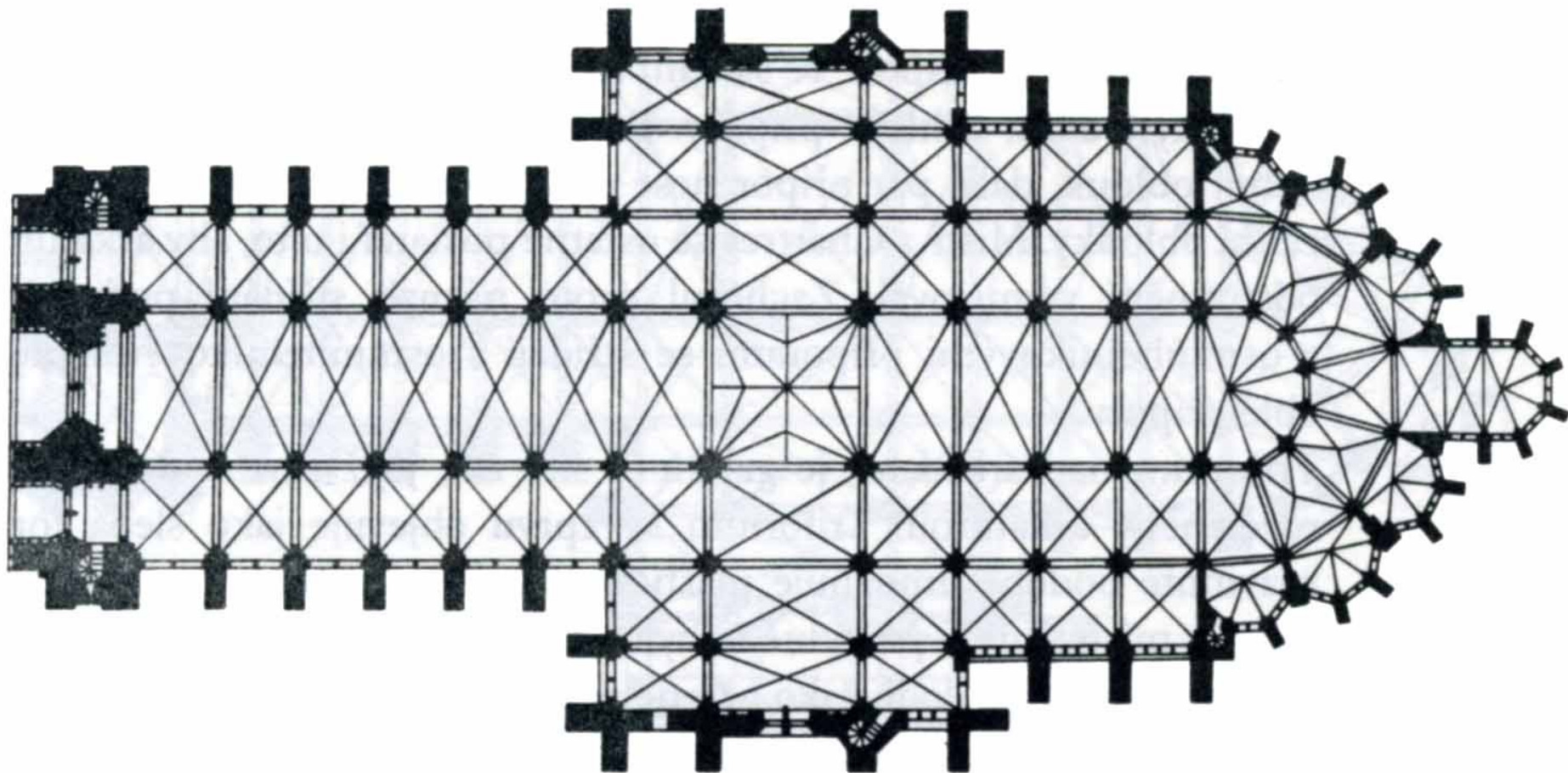

Notre-Dame, Amiens (po 1220)

Notre-Dame, Amiens

po 1220





Notre-Dame, Amiens

po 1220

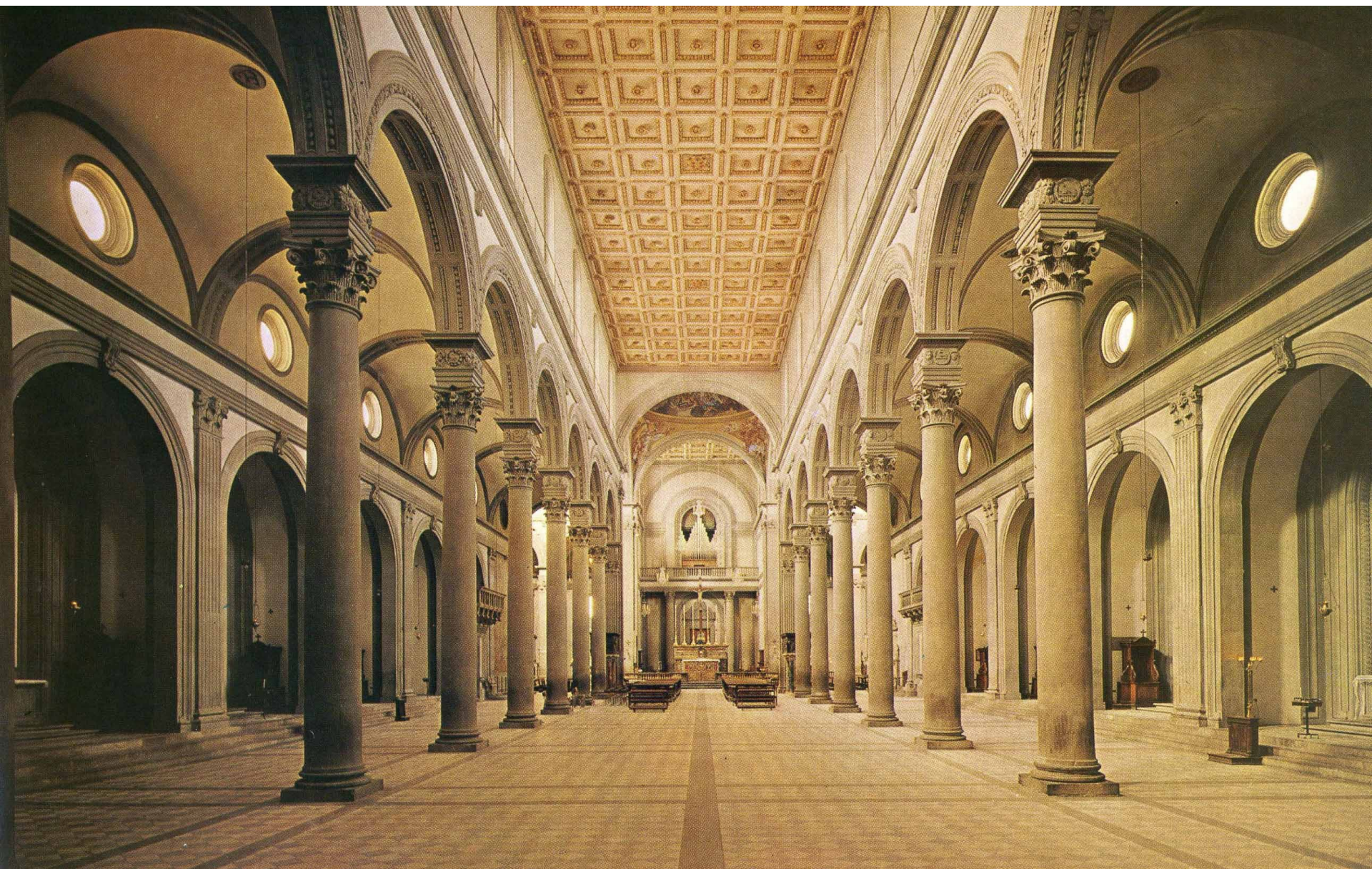

Filippo Brunelleschi: San Lorenzo (po 1419)

Klášter
Na Slovanech,
Praha

kol. 1370





C. D. Asam
a E. Q. Asam

Kostel sv. Jana
Nepomuckého,
Mnichov

1733–1734

Donato
Bramante

San Pietro
in Montorio,
Řím

1502



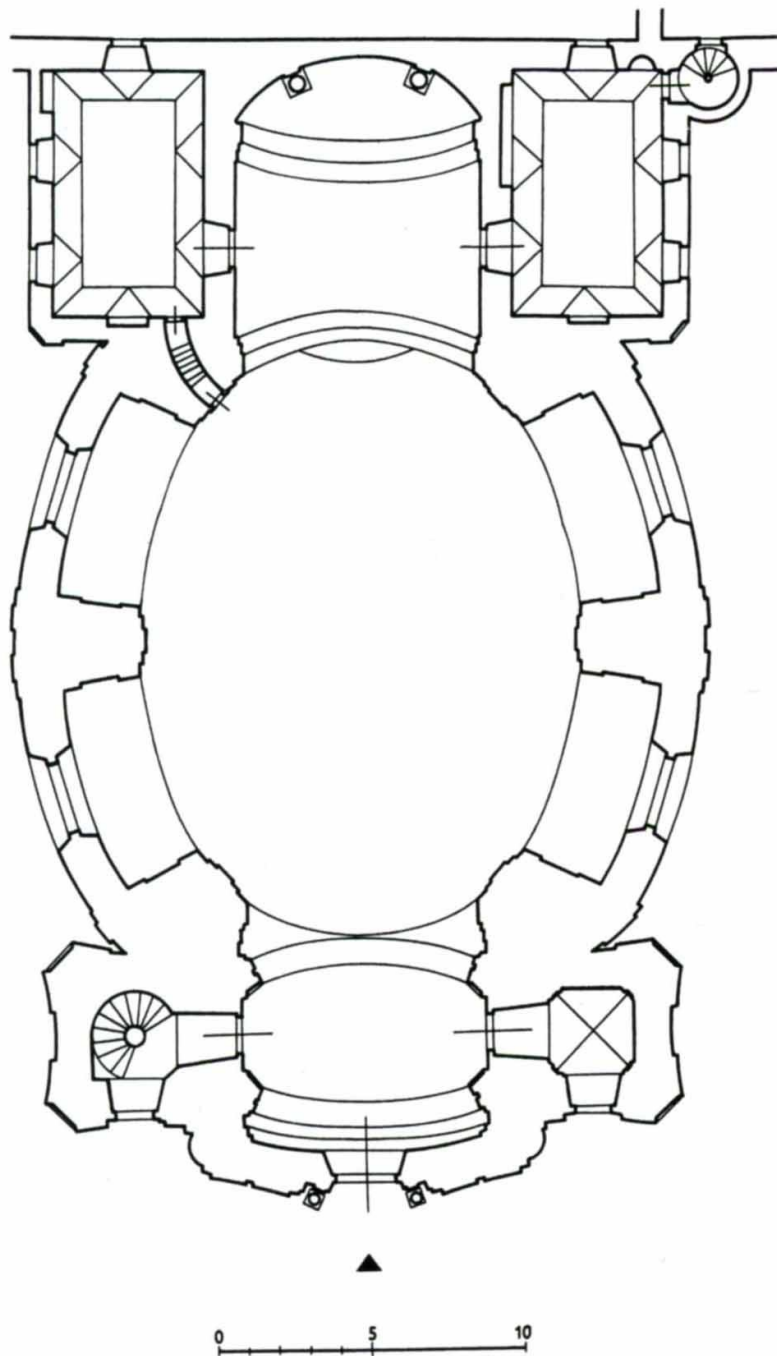

Ignác Josef Cyrani
z Bolleshausu

Kostel sv. Jana,
Kroměříž

1737–1768

architektura sakrální

II. funkce

biskupský kostel = katedrála

farní kostel

klášterní kostel

Kostel
sv. Alžběty,
Marburg

po 1235

*lectorium /
lettner*



architektura civilní

hrad

zámek

městský palác

veřejné budovy

*versailles > château fort >
> maison de la plaisance > maison*

palais > hôtel > maison

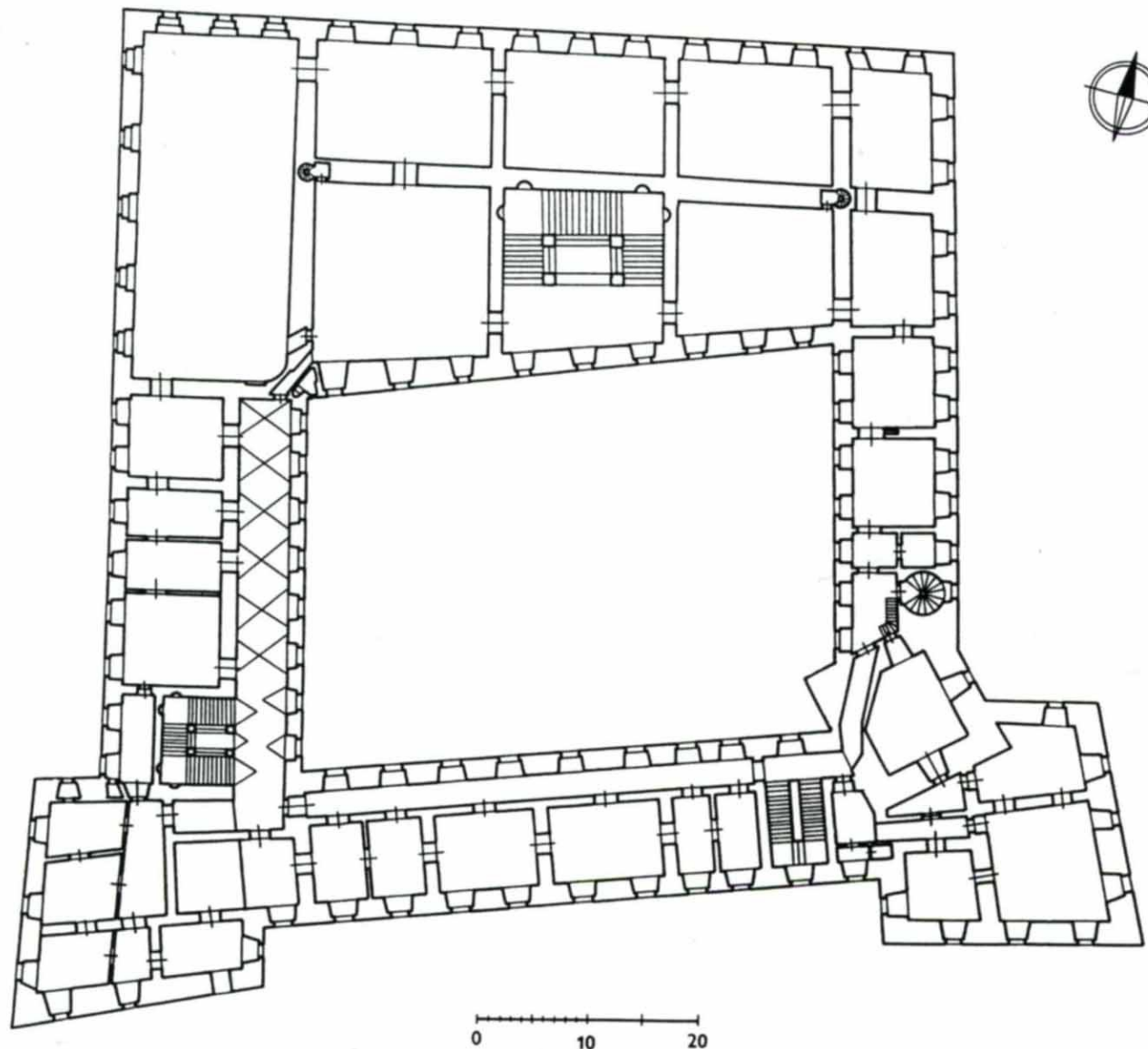

F. Luchese a G. P. Tencalla: Zámek, Kroměříž
1666–1698

hmota x prostor

tektonický x stereotomní

sloup x pilíř



Stonehenge,
Anglie

3100–1600
př. n. l.

Göreme,
Turecko

8. století

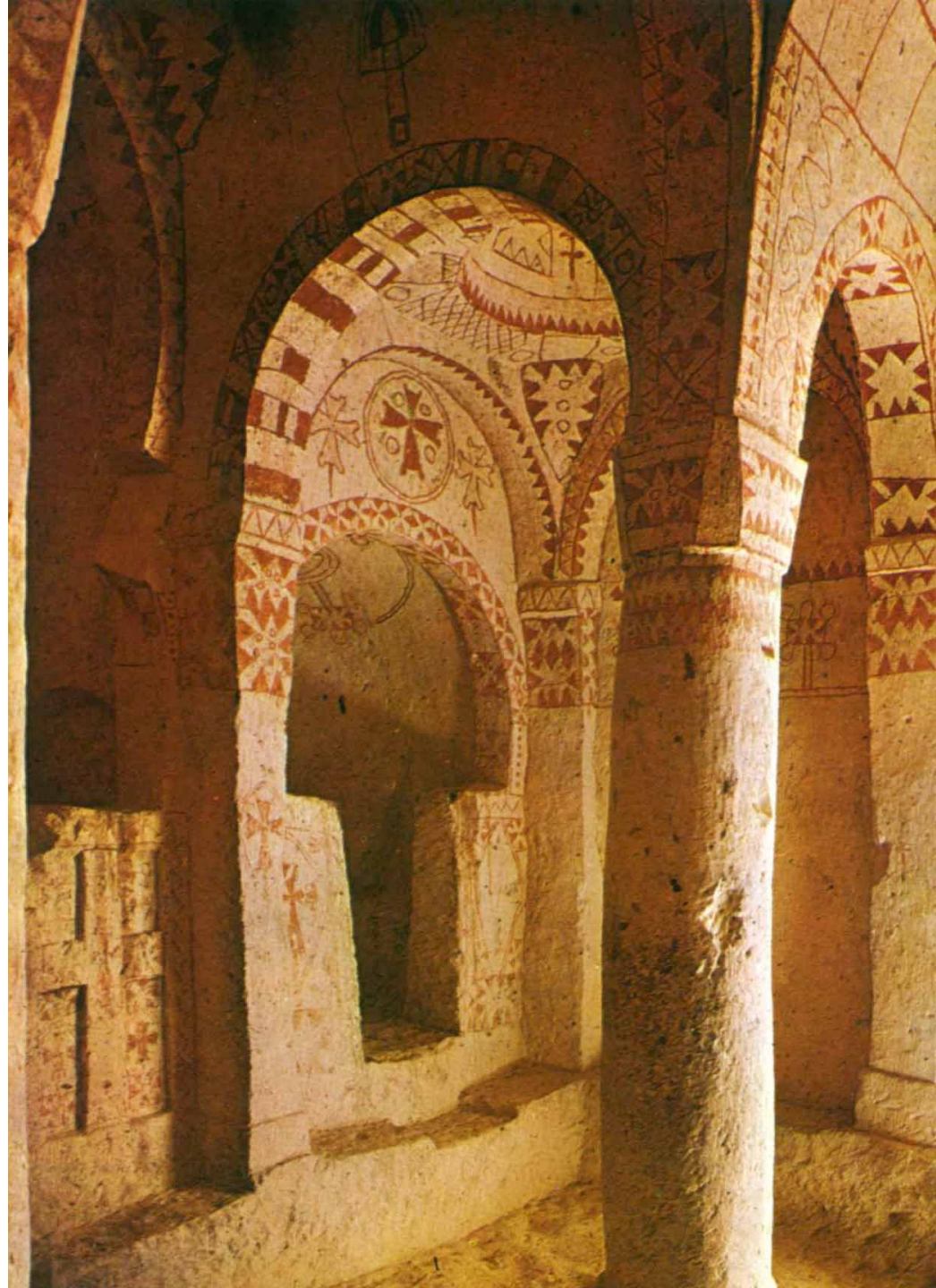



Bernward
z Hildesheimu

Kostel
sv. Michaela,
Hildesheim

1001–1033

G. P. Tencalla

Kanovnické
domy,
Kroměříž

1693–1698



aditivní x divizivní

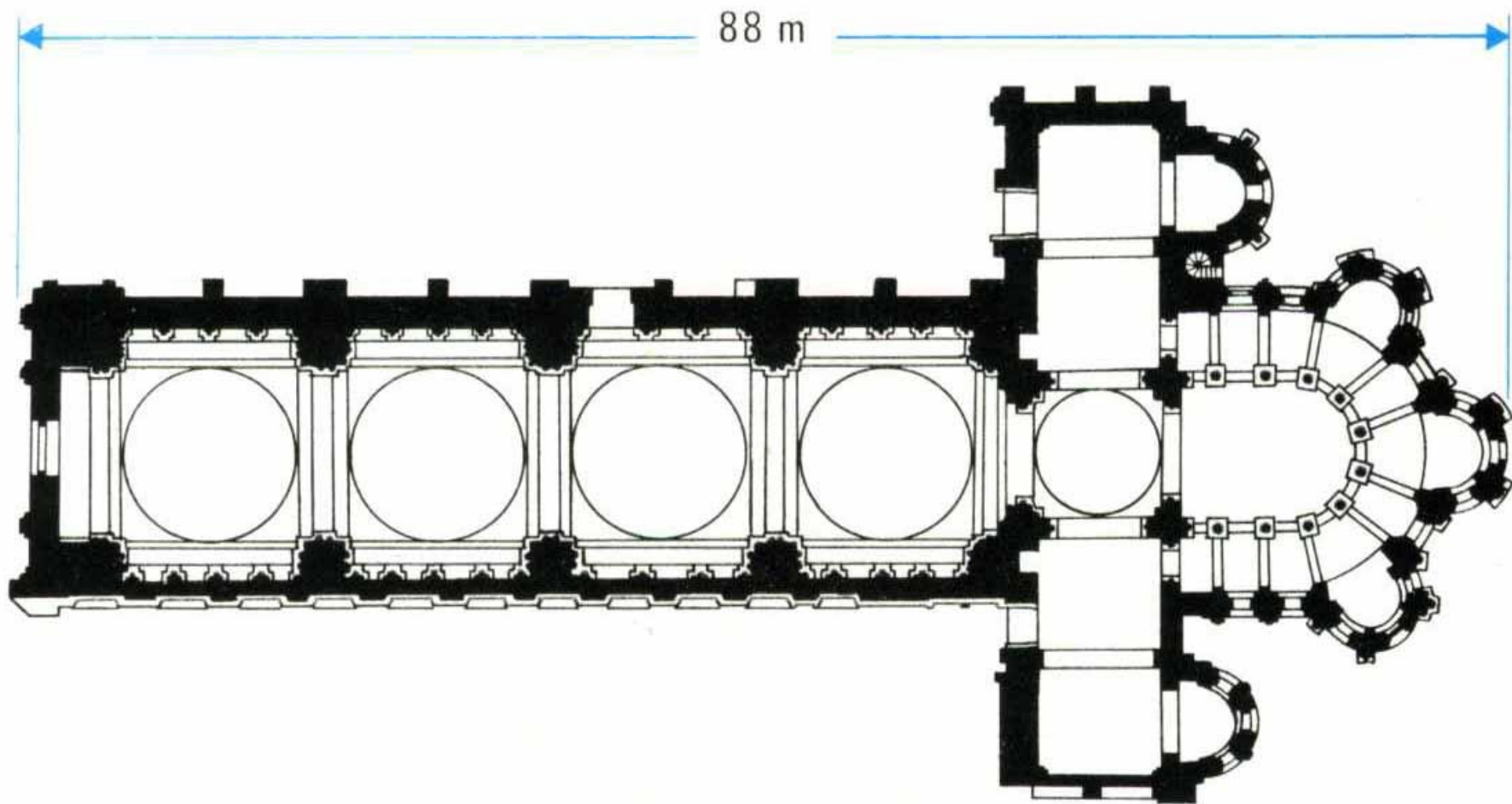

Fontevrault (před 1119)



Fontevraud

před 1119

*travé /
klenební úsek*

Katedrála
sv. Petra,
York

1291–1340





Philip Johnson: Vlastní dům, New Canaan
1949

světlo

světelný tok x světelné sjednocení



Filippo Brunelleschi: Santo Spirito, Florencie
(po 1434)



Saint-Denis

po 1231



G. P. Tencalla, D. Martinelli a L. S. Kaltner
Svatý Kopeček u Olomouce (po 1669)

Ignác Josef Cyrani
z Bolleshausu

Kostel sv. Jana,
Kroměříž

1737–1768



terminologie

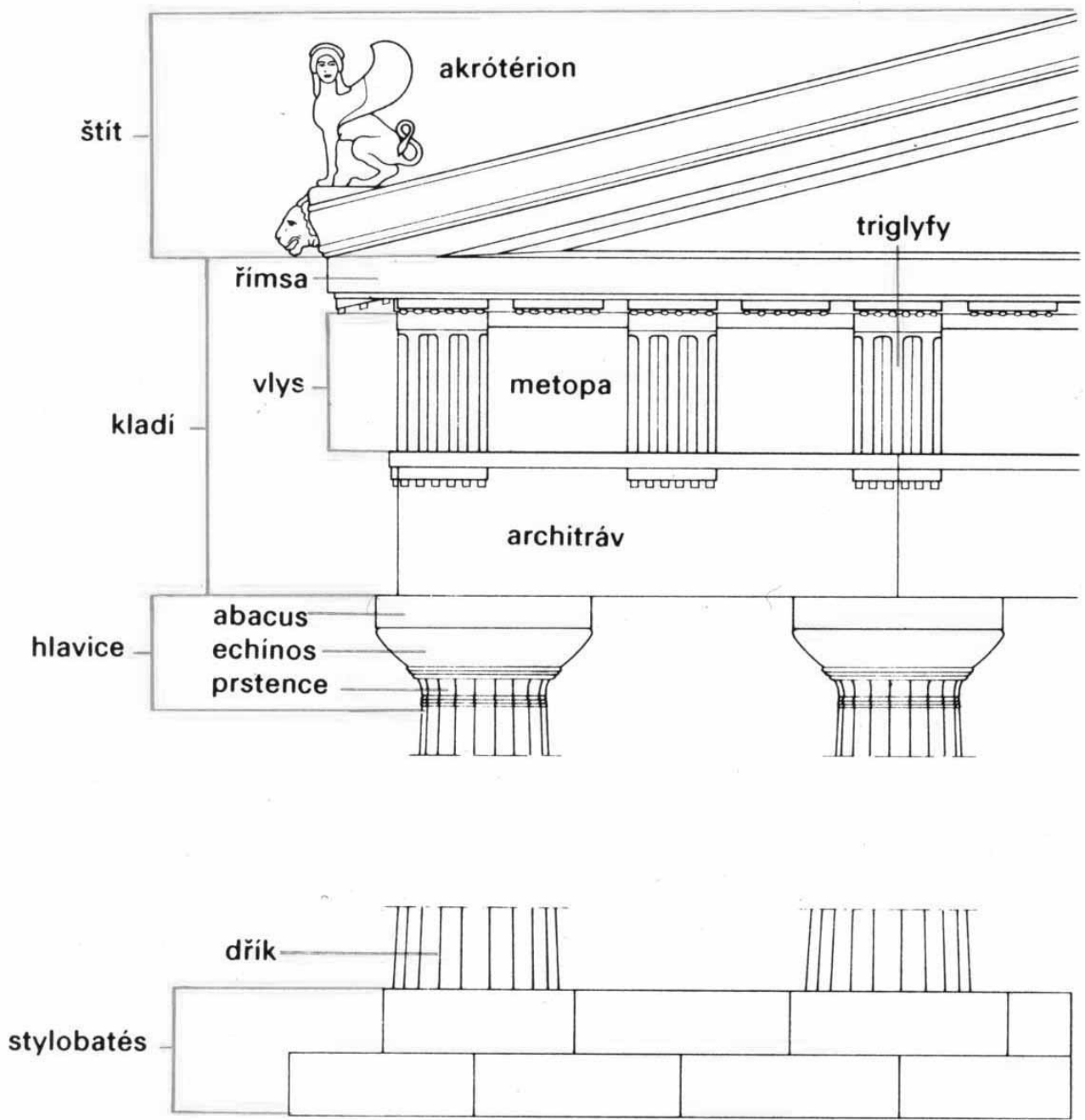

dórský řád

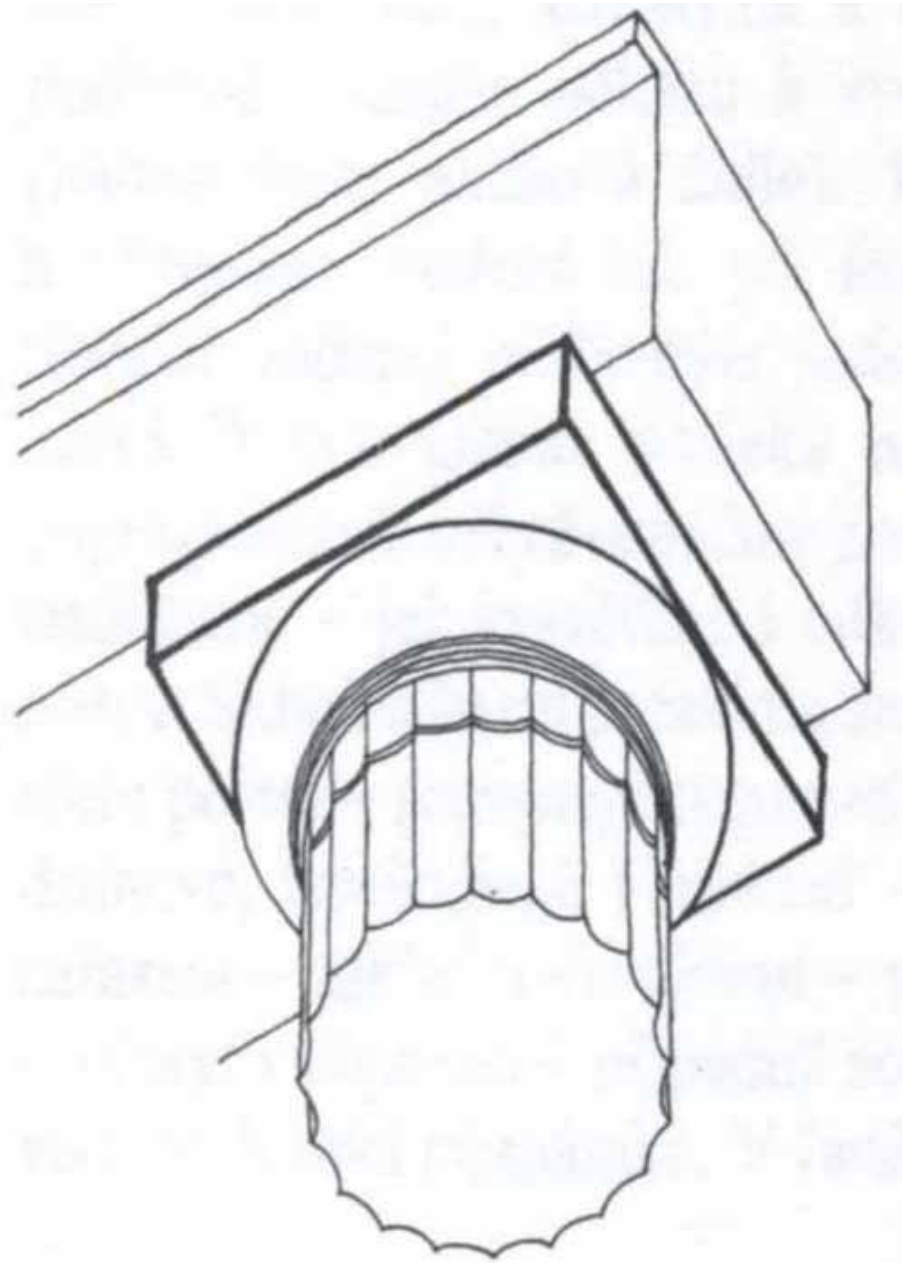

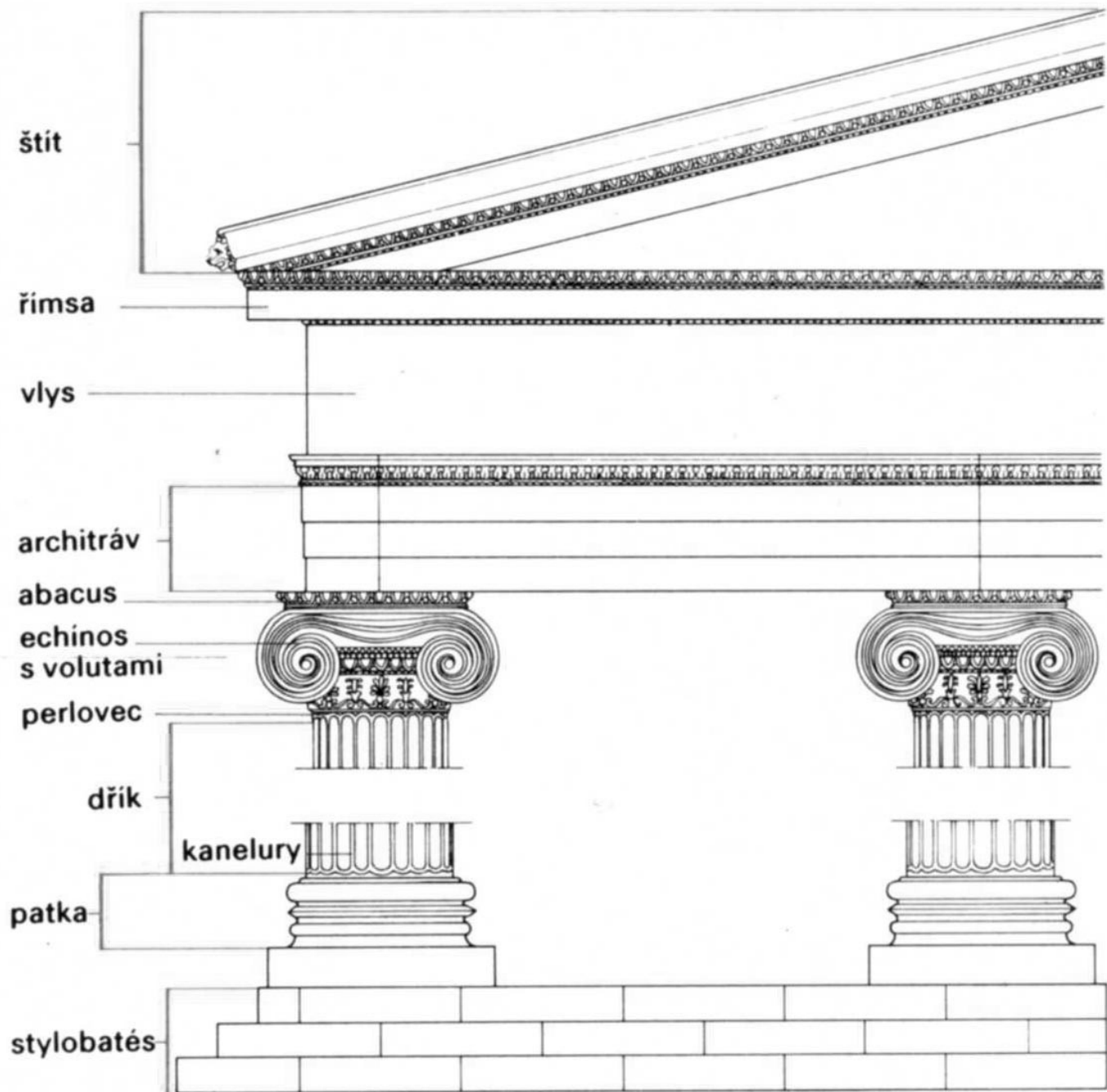

iónský řád

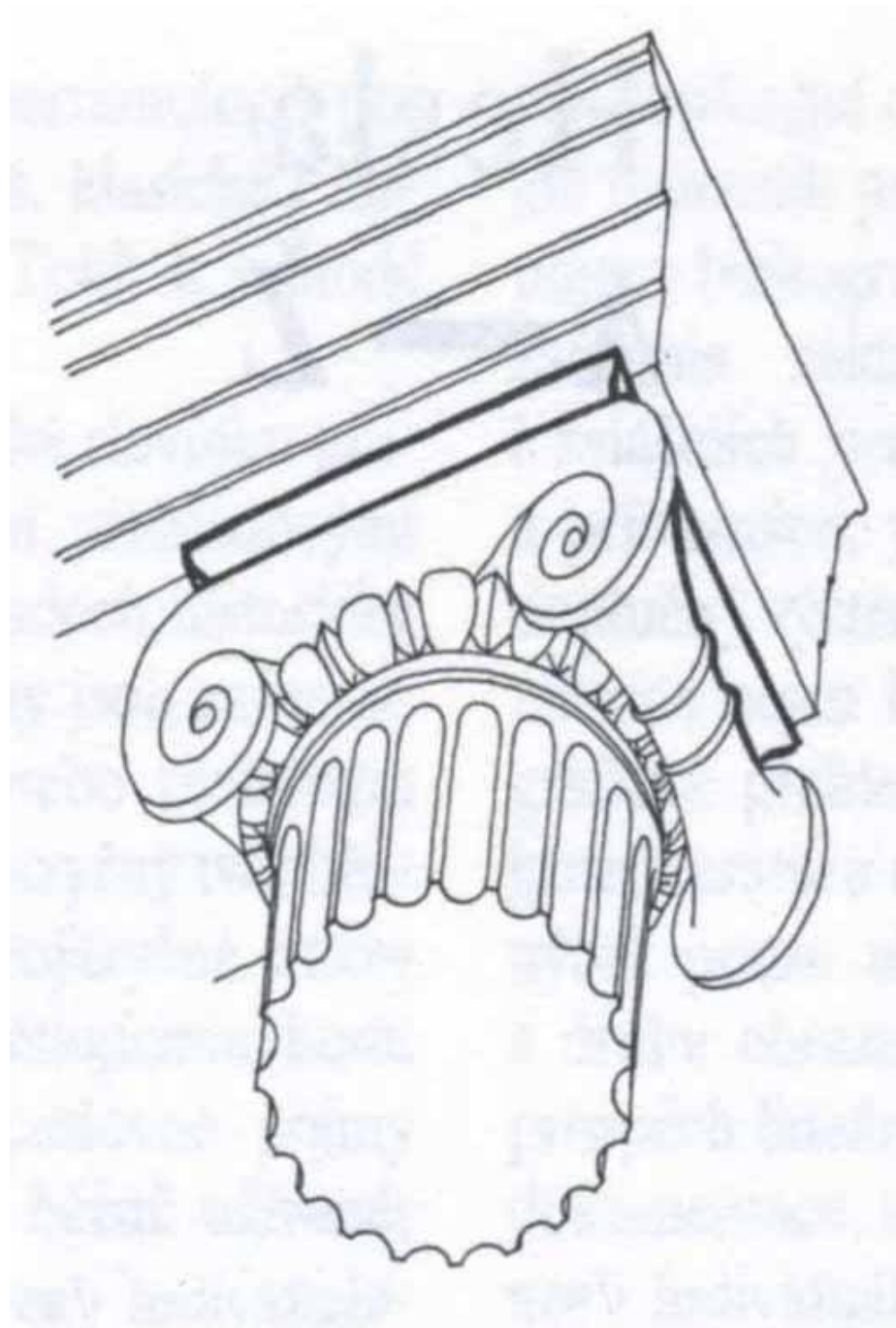

iónský řád

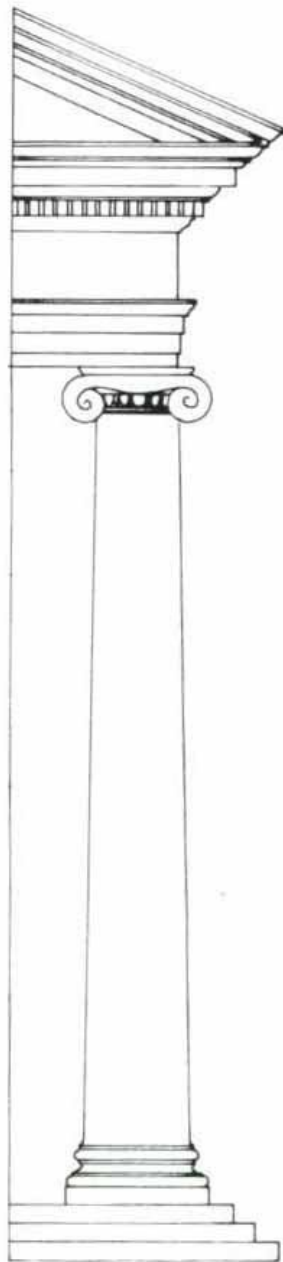

korintský řád

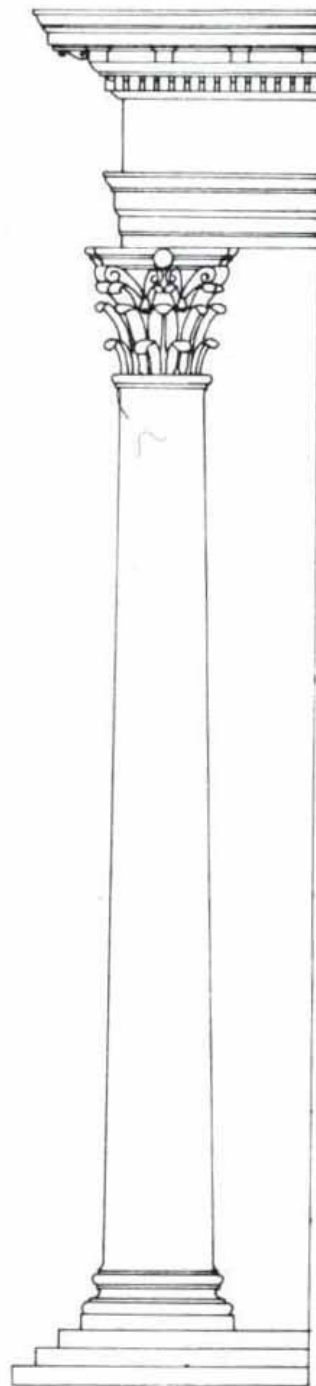

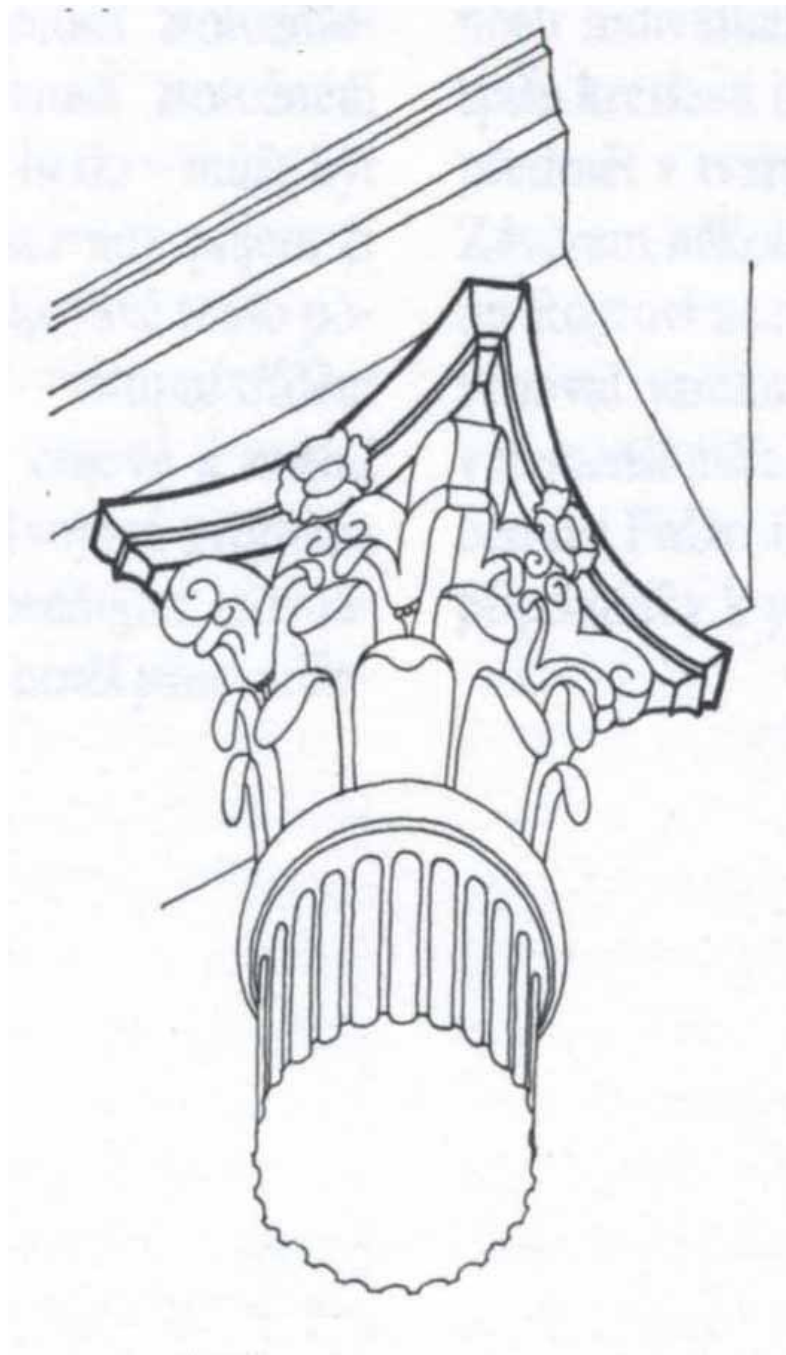

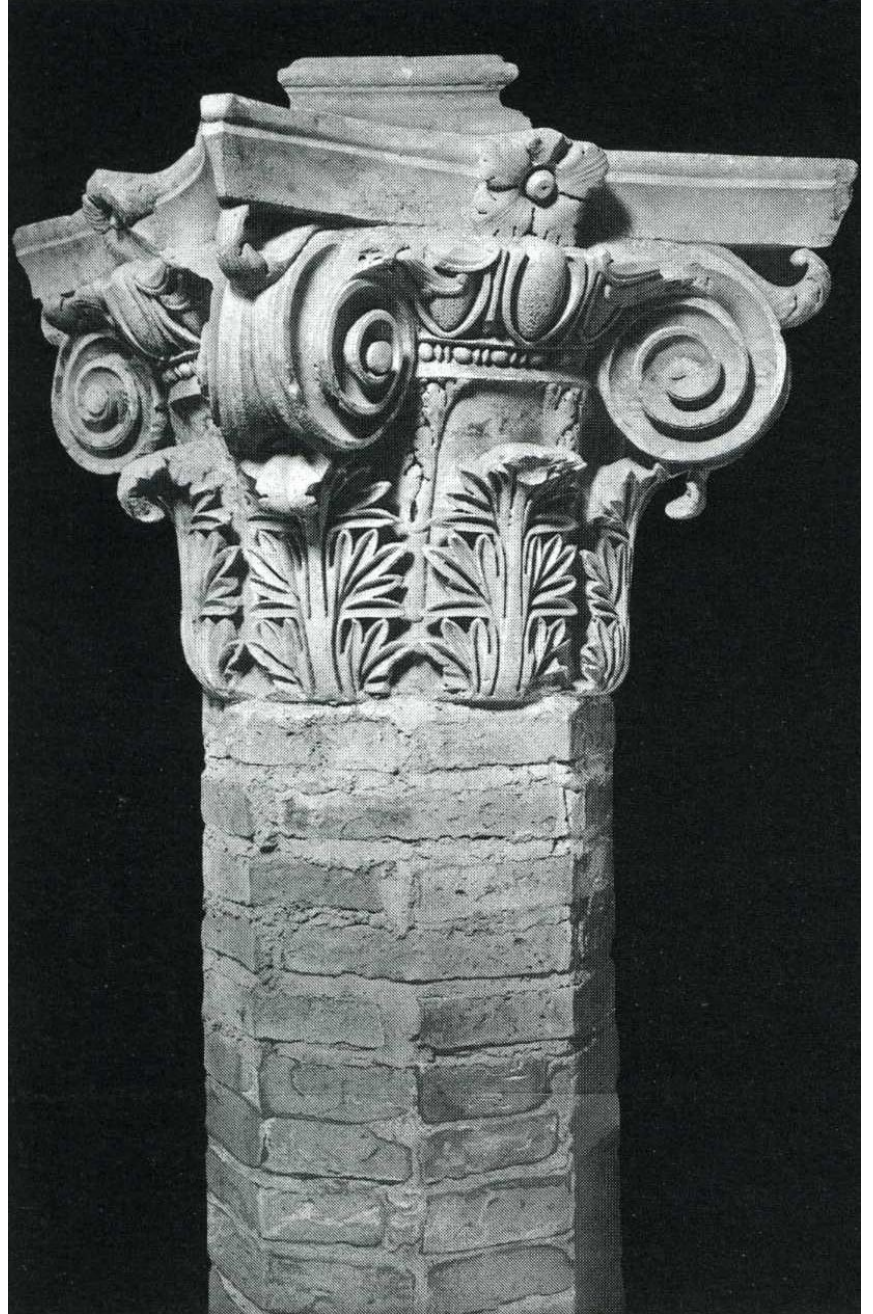

kompozitní řád

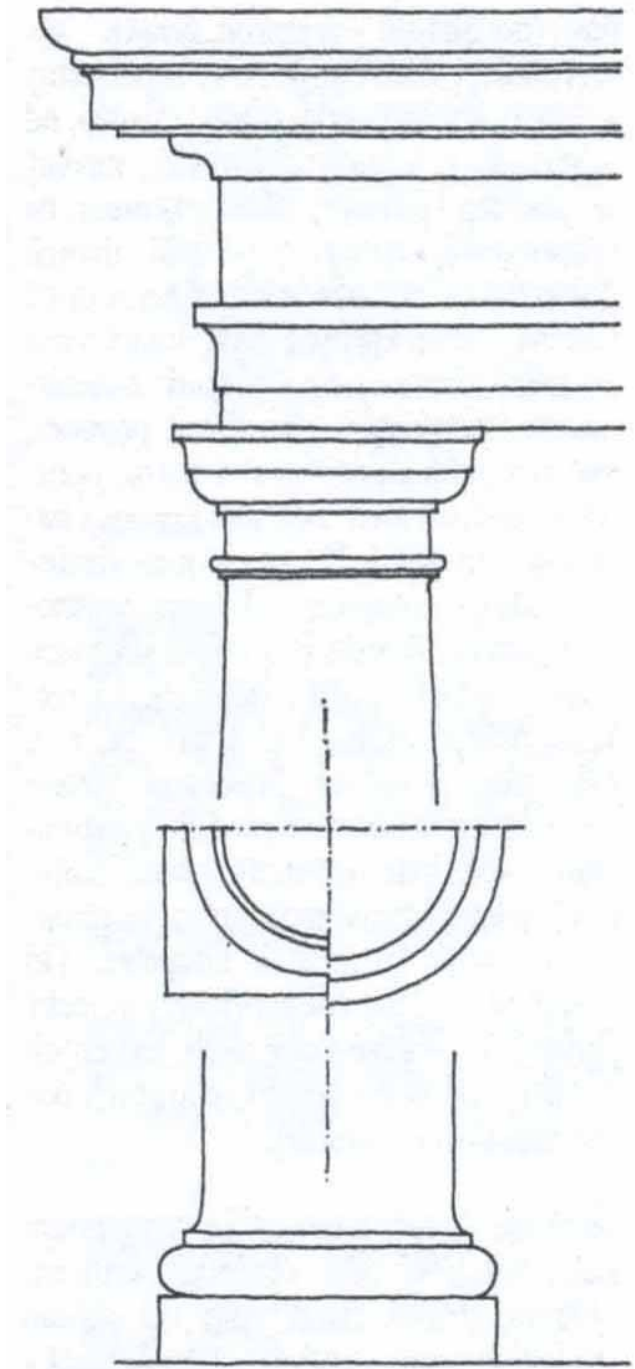

toskánský řád



Koloseum, Řím (před 82)
superpozice řádů

Antonio
da Sangallo

Palazzo
Farnese,
Řím

po 1514





F. Caratti: Černínský palác, Praha (1668–1677)
kolosální řád



Filippo
Brunelleschi

Santo Spirito,
Florence

po 1434



K. Dientzenhofer: Kostel sv. Markéty (1708/21)
zalamované kladí

Gianlorenzo
Bernini

Baldachýn
v bazilice
sv. Petra,
Vatikán

1624–1633

tordované dřívky

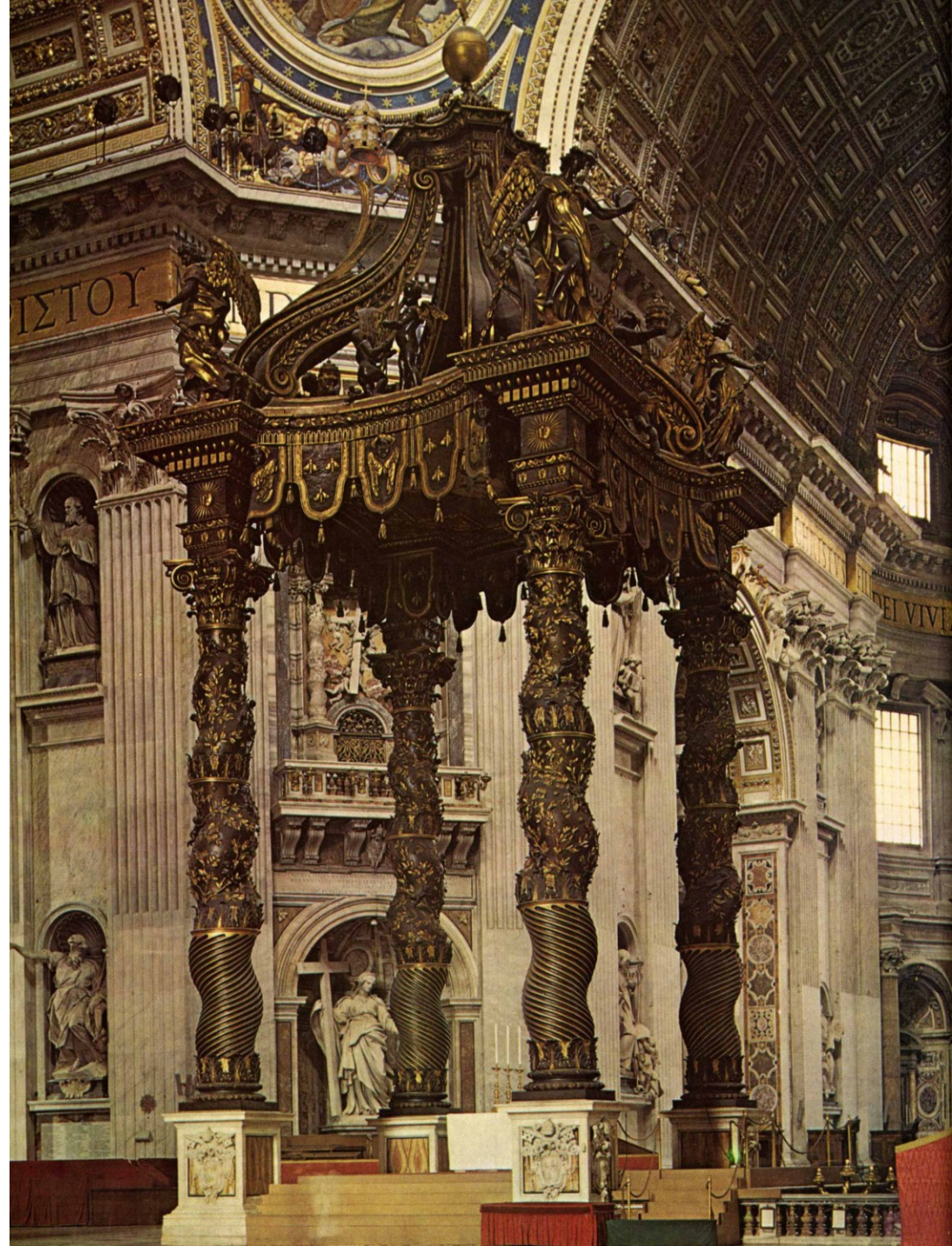

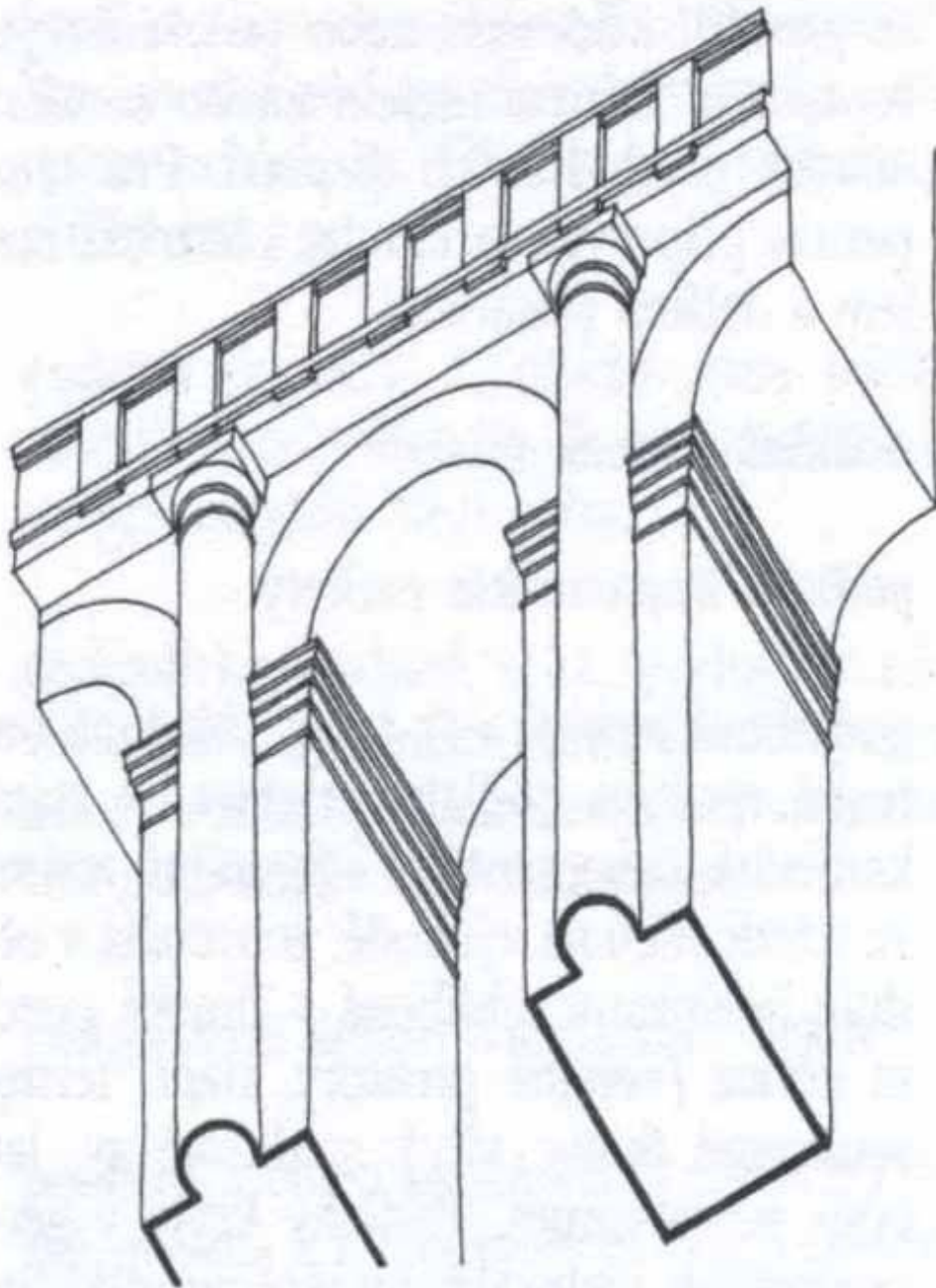

polosloup

pilastr

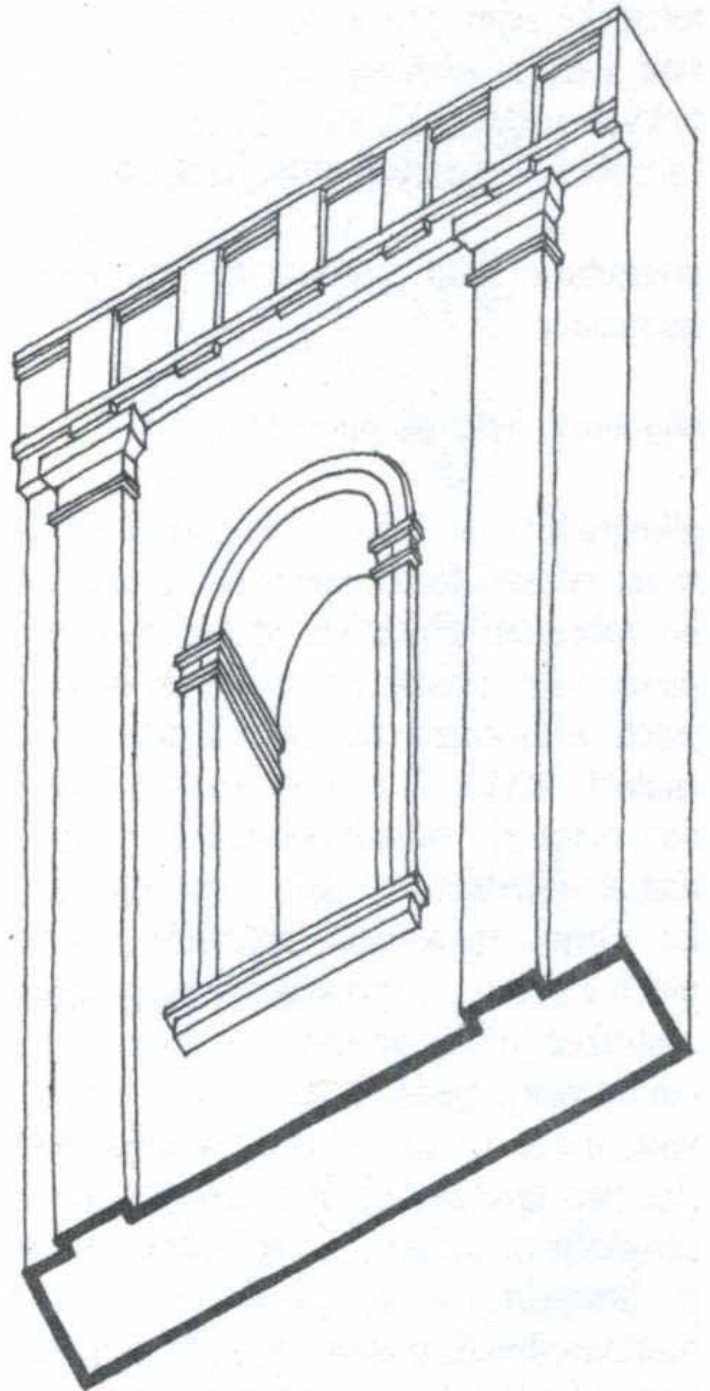



Erechtheion,
Athény

421–406 př. n. l.

karyatida

F. M. Brokof

Balkón
Morzinského paláce,
Praha

1714

atlas



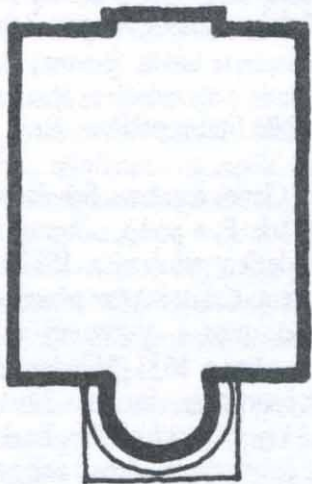
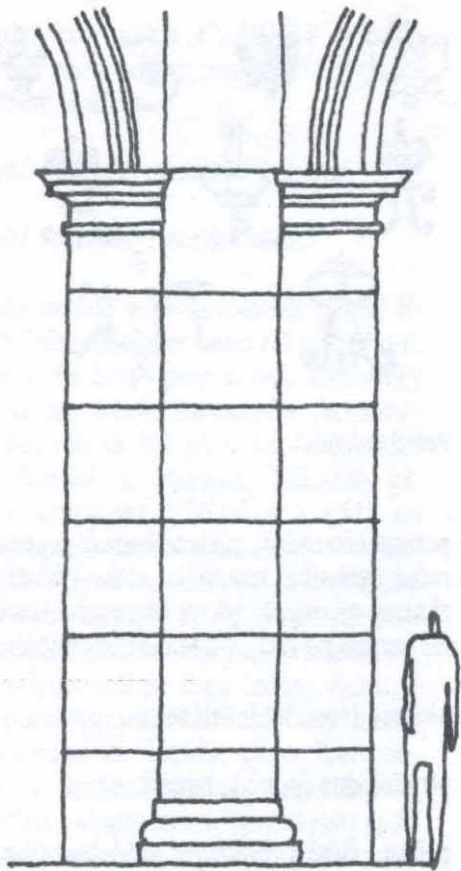

pilíř

lizéna

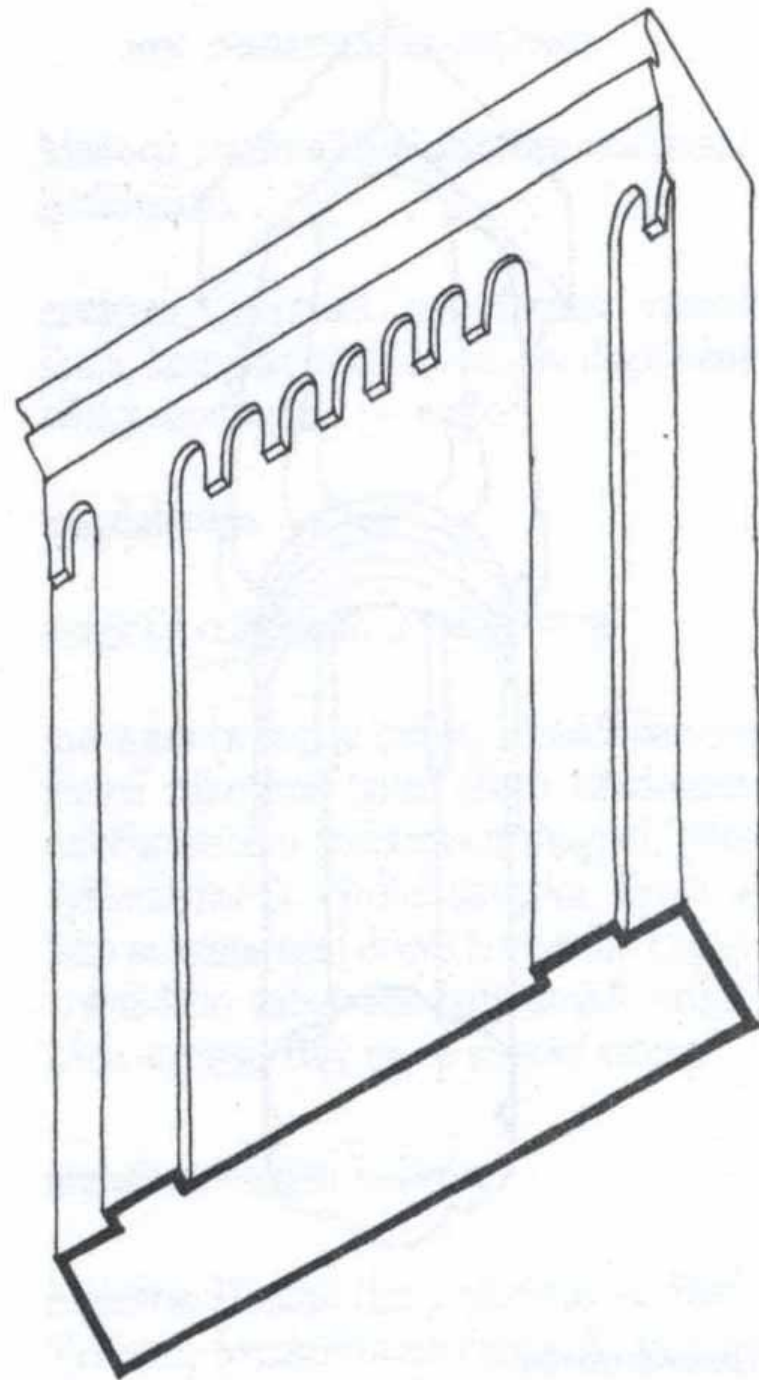



Mauzoleum Gally Placidie, Ravenna (kol. 450)



Palác
Althanů,
Znojmo

kol. 1780

*lizénový
rám*



Bramante: Santa Maria della Pace, Řím (1504)
arkáda x kolonáda



Iktínos a Kallikratés: Parthenón (447/32 př. n. l.)
peristyl

J. G. Soufflot

Panthéon,
Paříž

po 1756

portikus



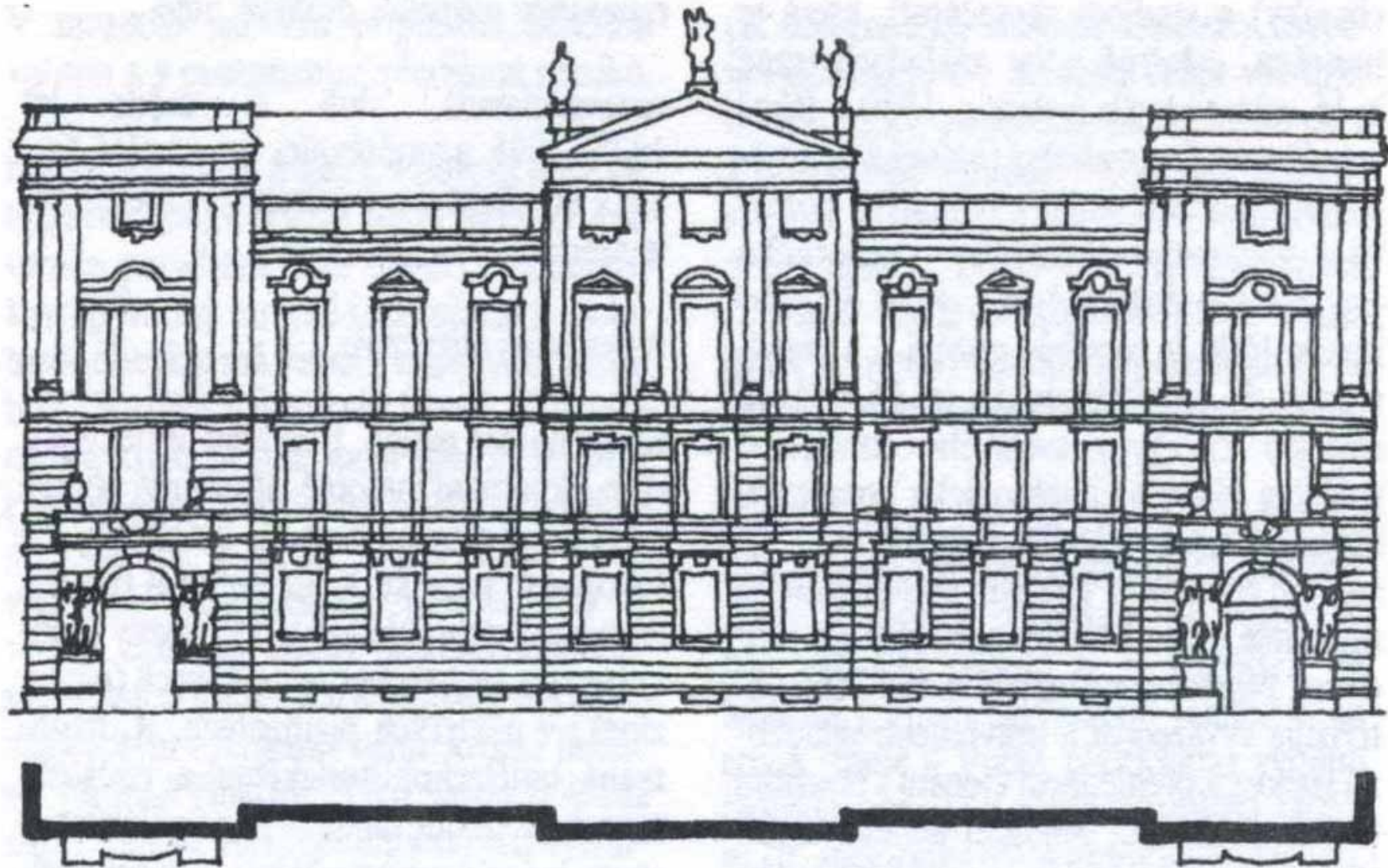

nárožní

*osový
rizalit*

nárožní

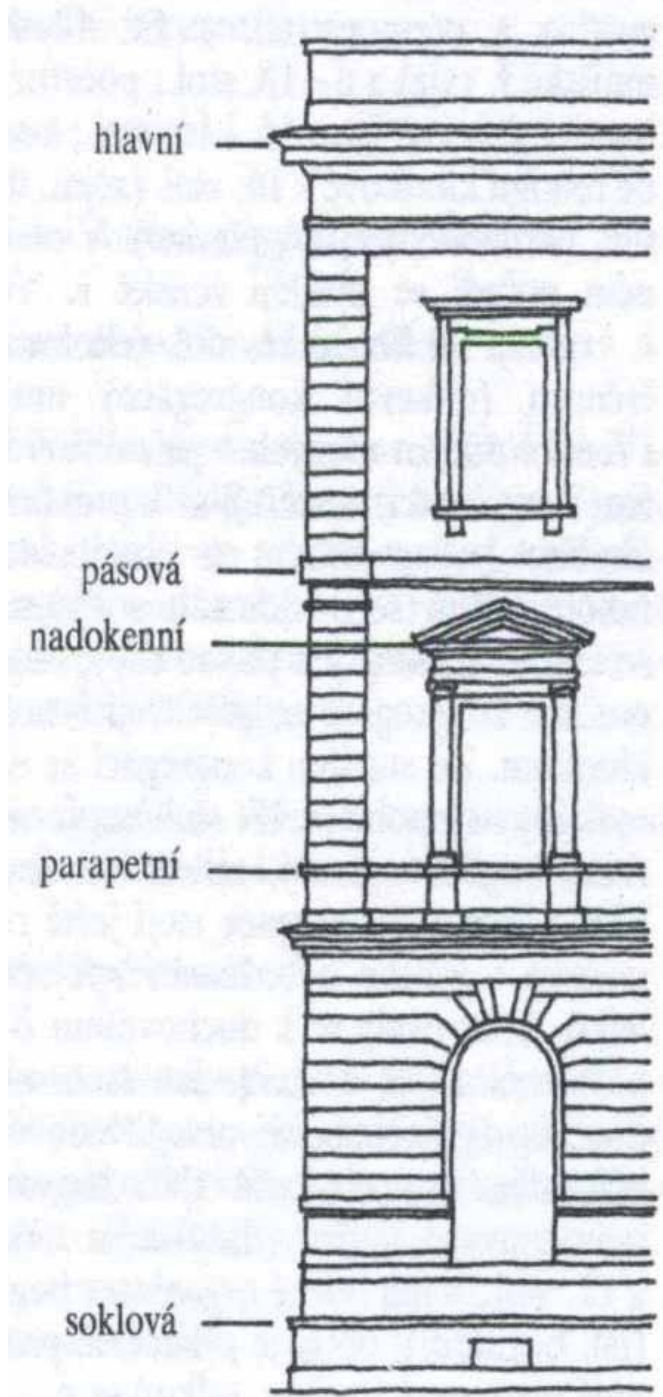

(kordonová) římsa

armování





rustika

bosáž





Michelangelo: Palazzo Farnese, Řím (po 1514)
fronton trojúhelníkový x segmentový

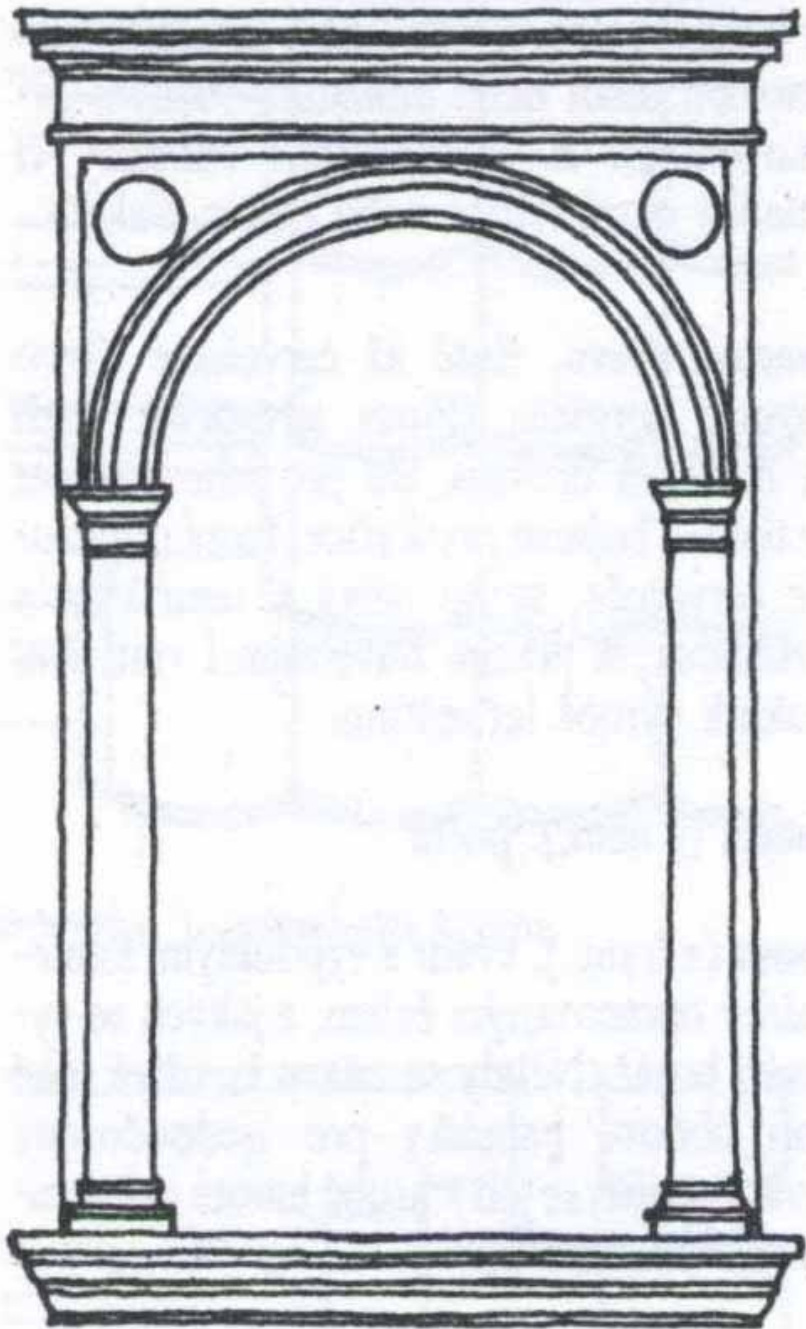

*bramantovské
okno*

cvikl

*šambrána /
okenní ostění*

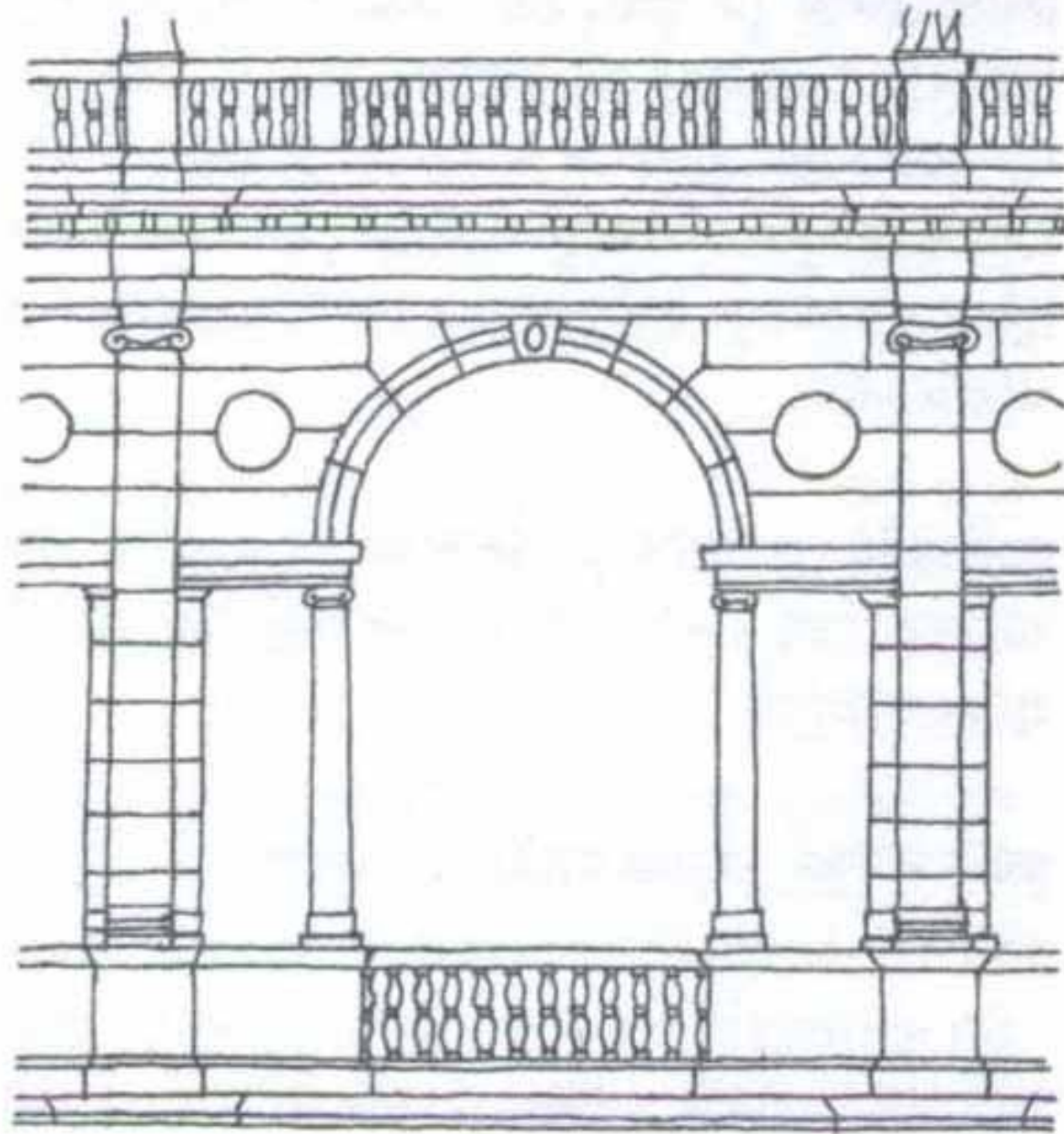

serliána → palladiovský motiv



Palladio: Palazzo della Ragione, Vicenza
po 1549



J. F. Engel: Chrám Tří Grácií u Břeclavi
1824–1825



V. Louis: Grand Théâtre, Bordeaux (1777/80)
francouzské okno

Domenico
Martinelli

Klášterní
Hradisko
u Olomouce

začátek 18. stol.

Fensterportal





kasulové okno

Baldassare
Longhena

Santa Maria
della Salute,
Benátky

po 1630

termální okno



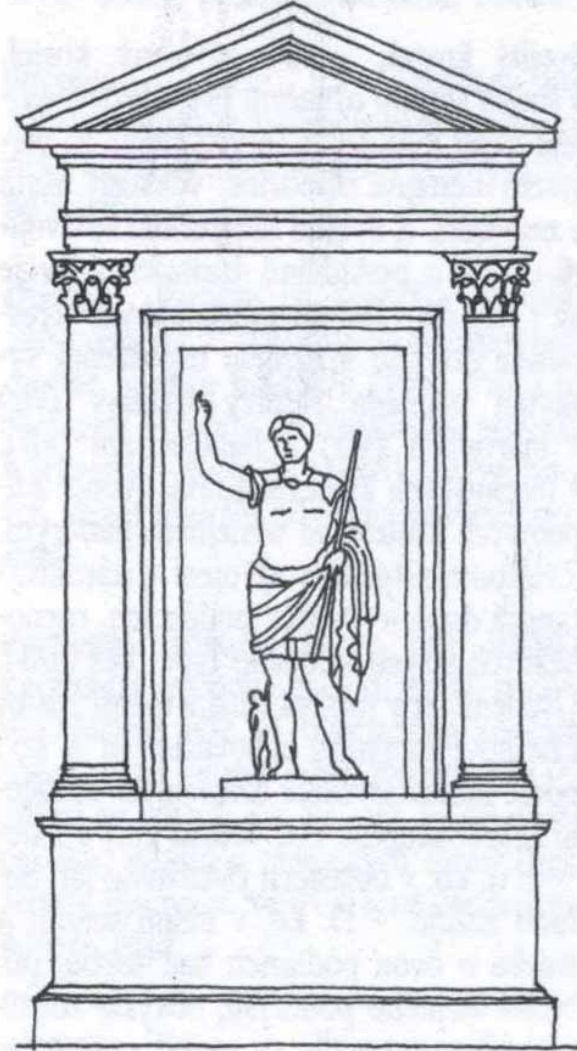

nika

edikula

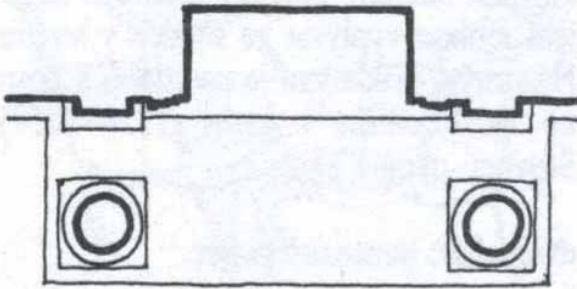

Donatello

Svatý Marek,
Or San Michele,
Florencie

1411–1413

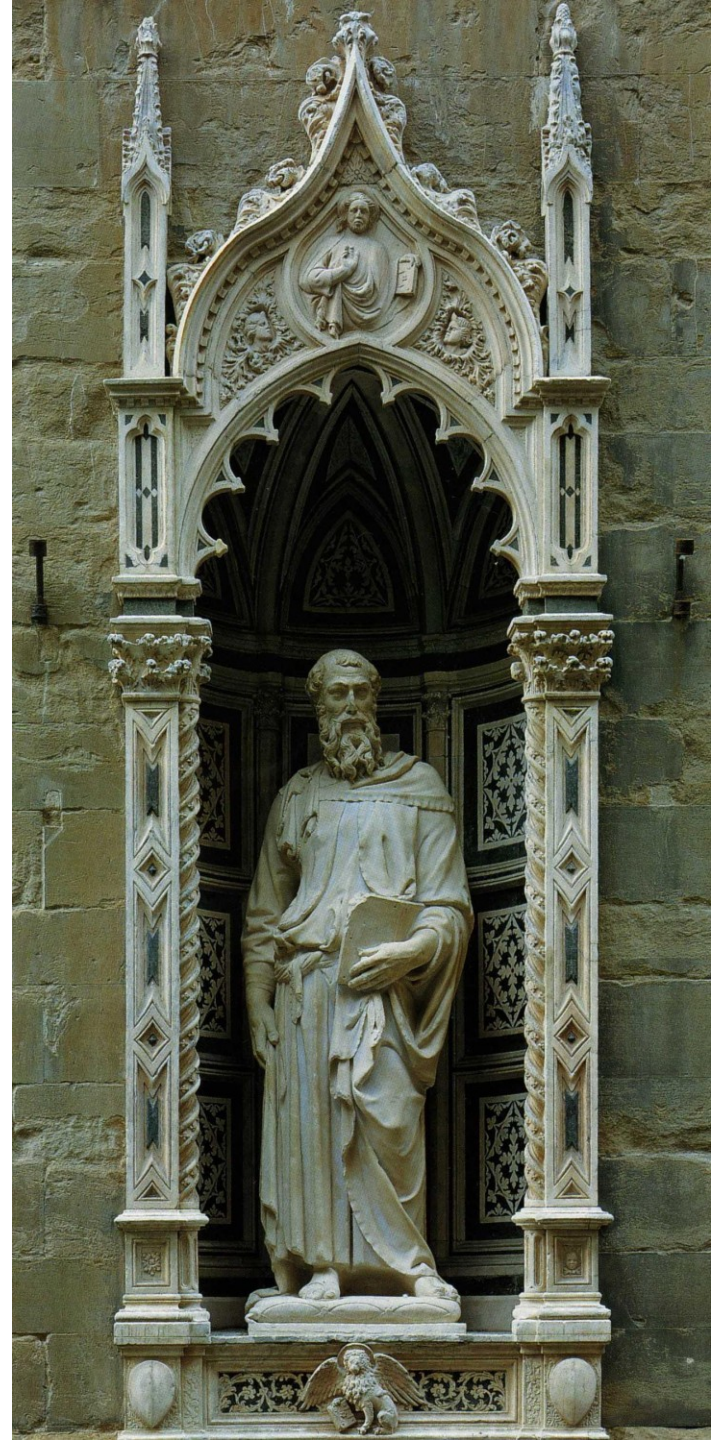

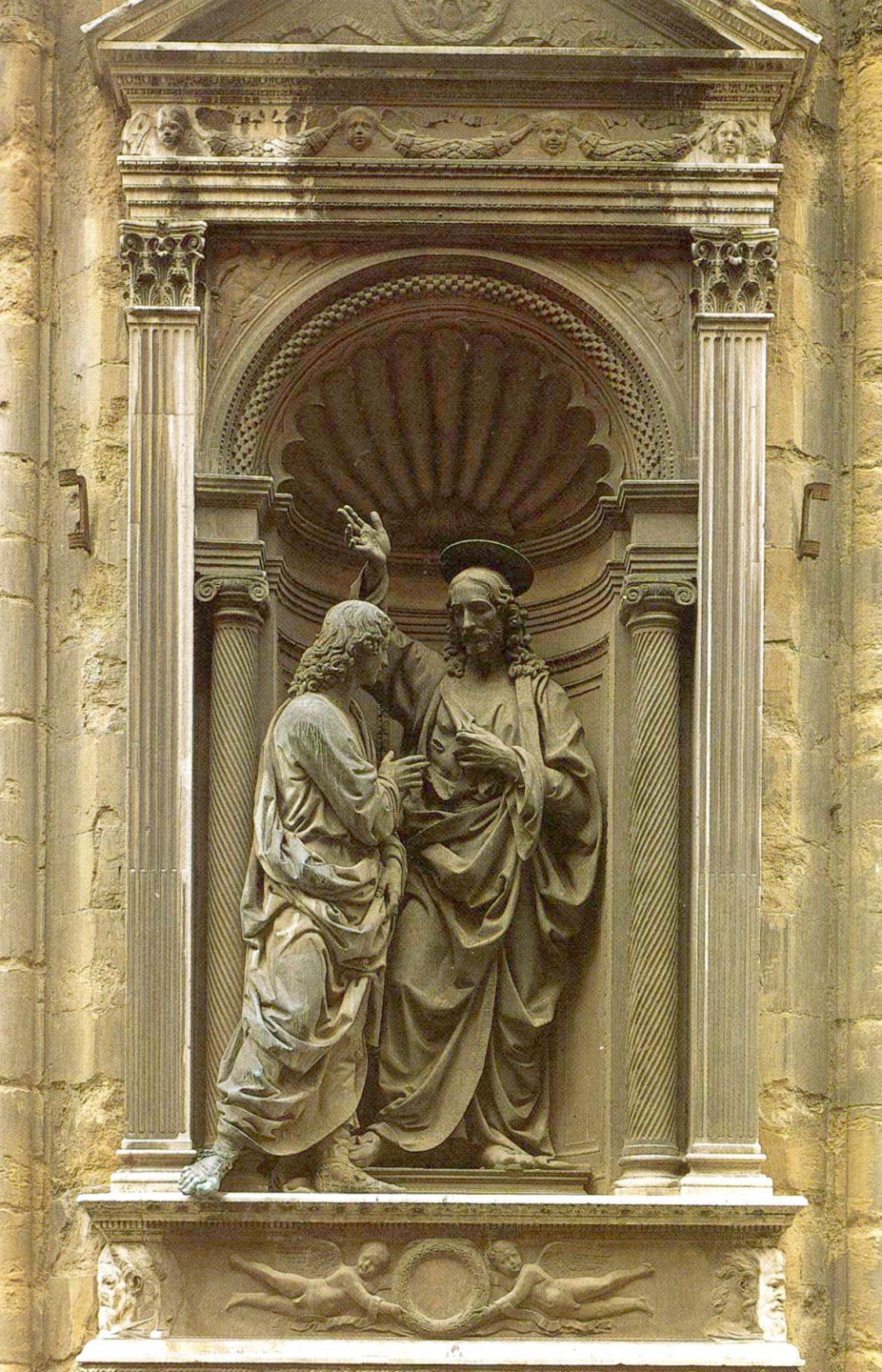

Andrea
del Verrocchio

Nevěřící Tomáš,
Or San Michele,
Firence

1467–1483

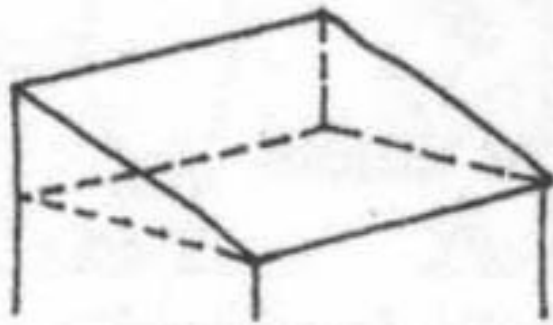

**střecha
pultová**

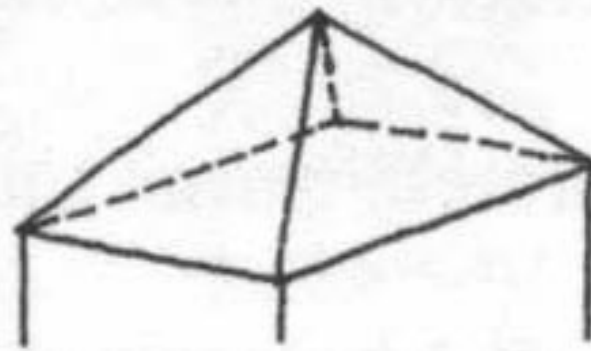

**střecha
stanová**

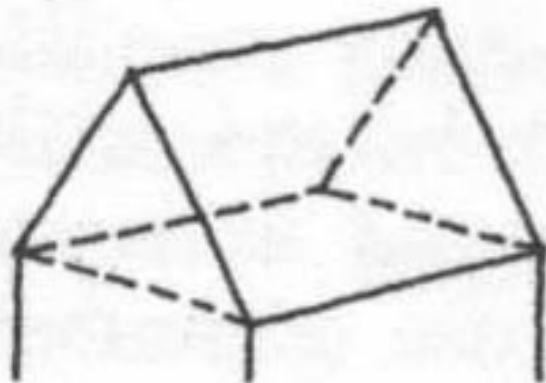

**střecha
sedlová**

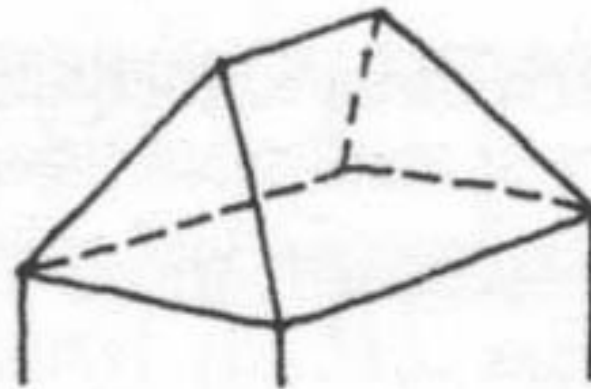

**střecha
valbová**

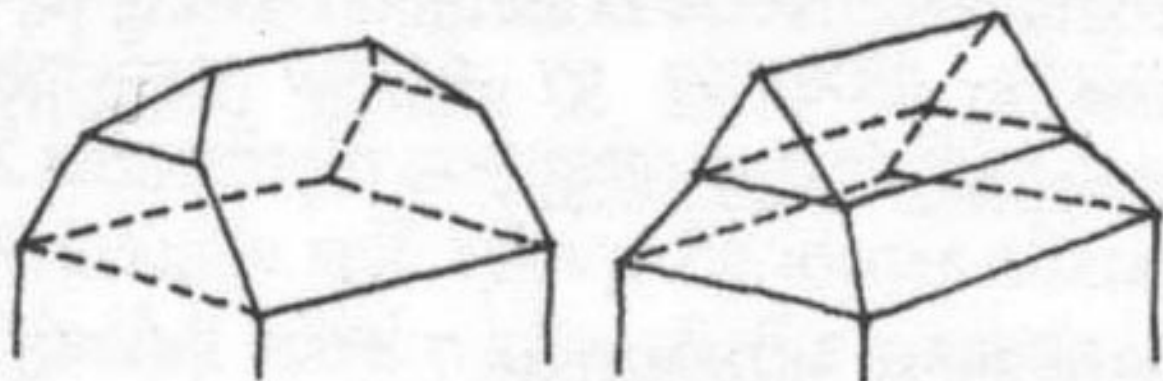

střecha, polovalbová (dvou typů)

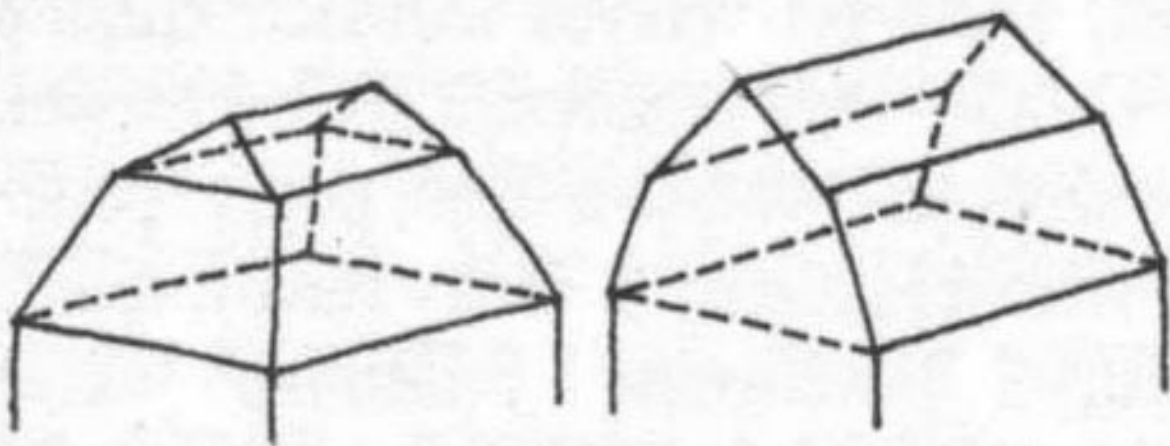

střecha, mansardová (dvou typů)

Jules
Hardouin-
Mansart

Versailles

1668

*mansardová
střecha*



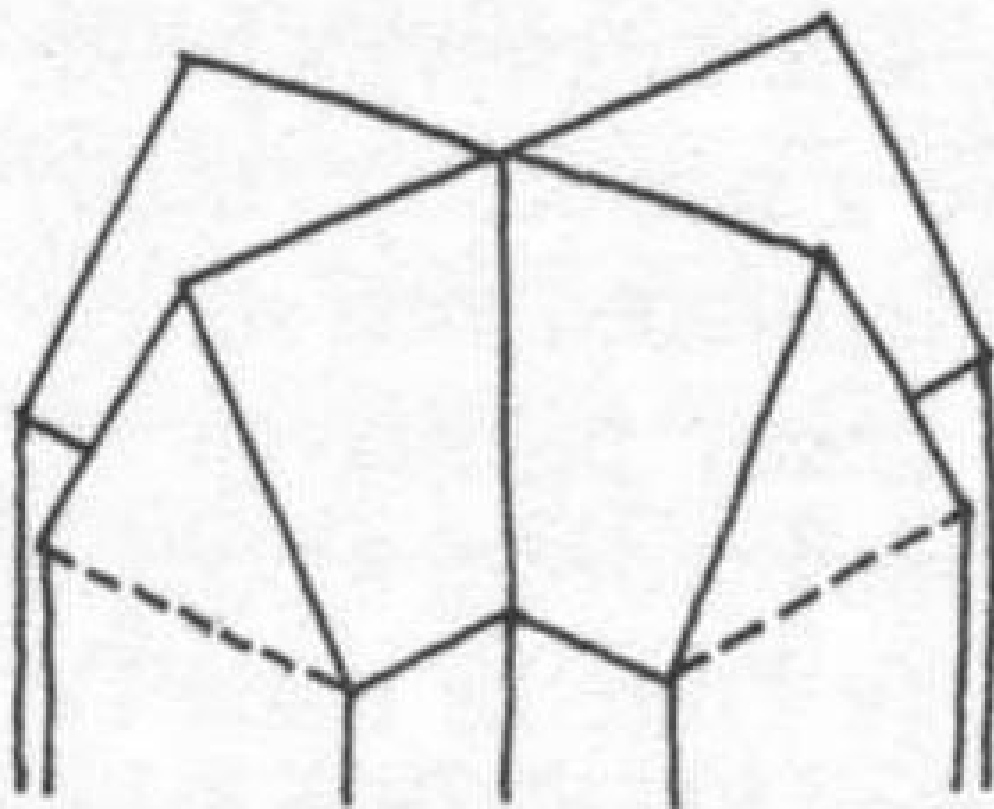

**střecha
křížová**

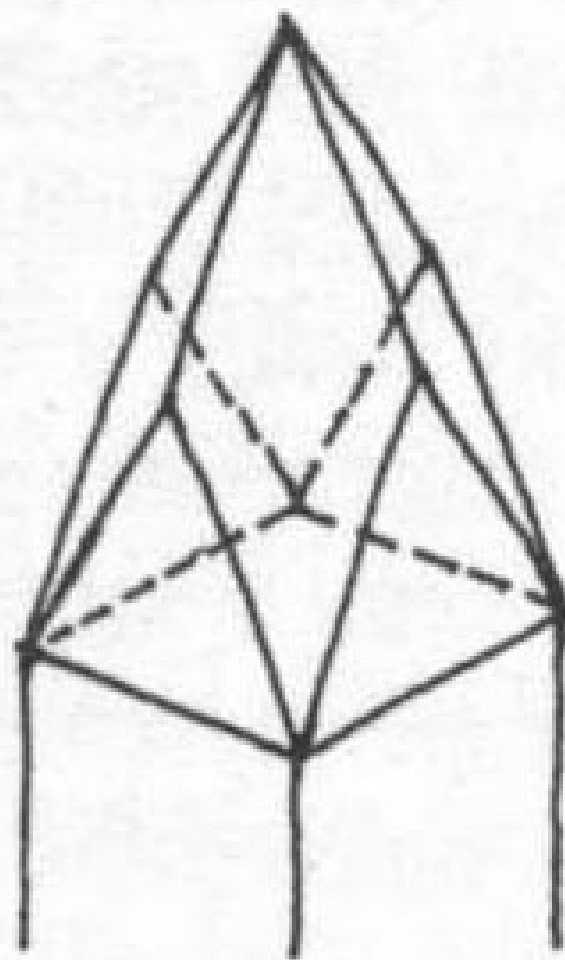

**střecha
routová**

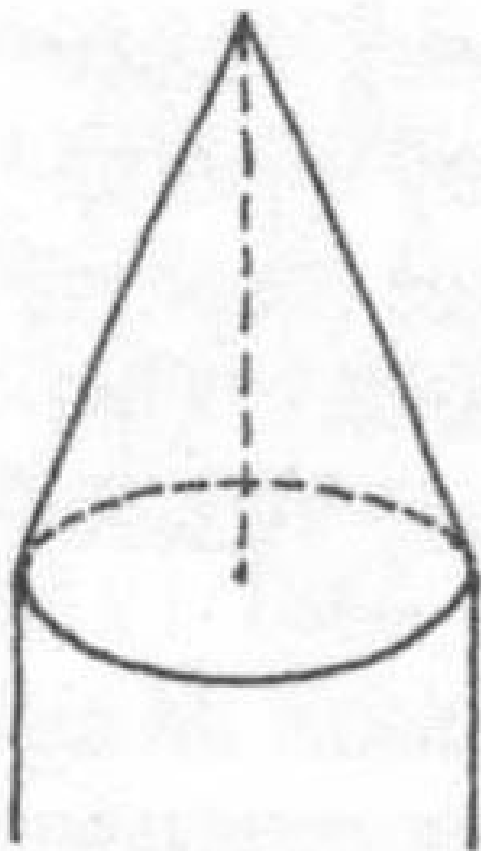

**střecha
kuželová**

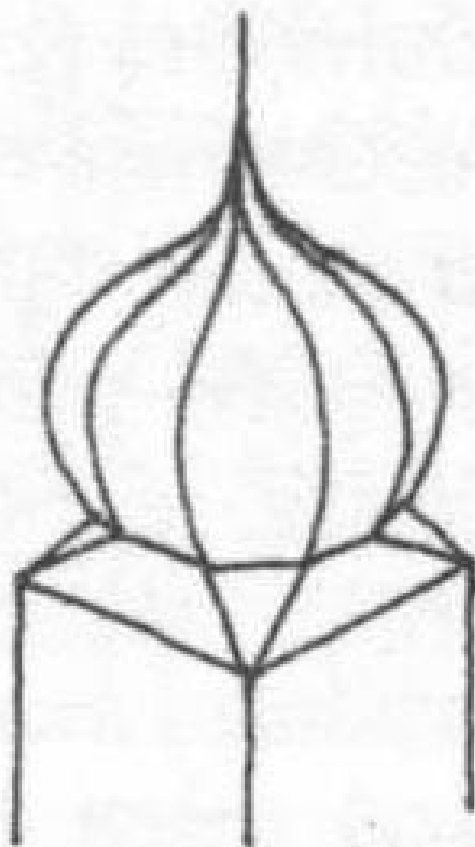

**střecha
cibulová**

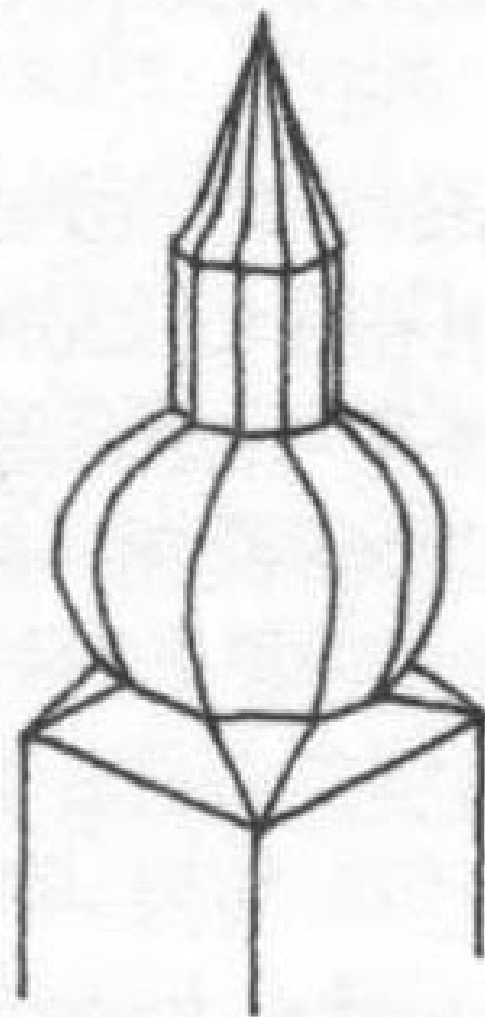

**střecha
cibulová
s lucernou**

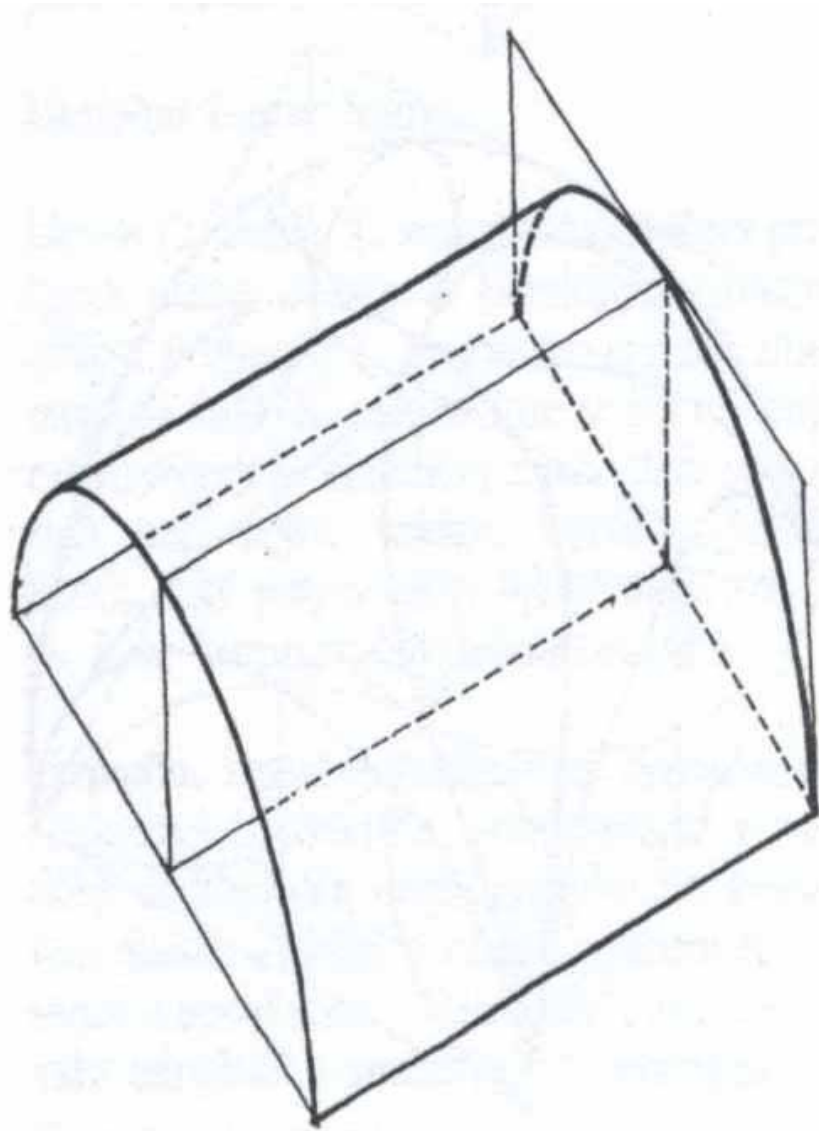

valená

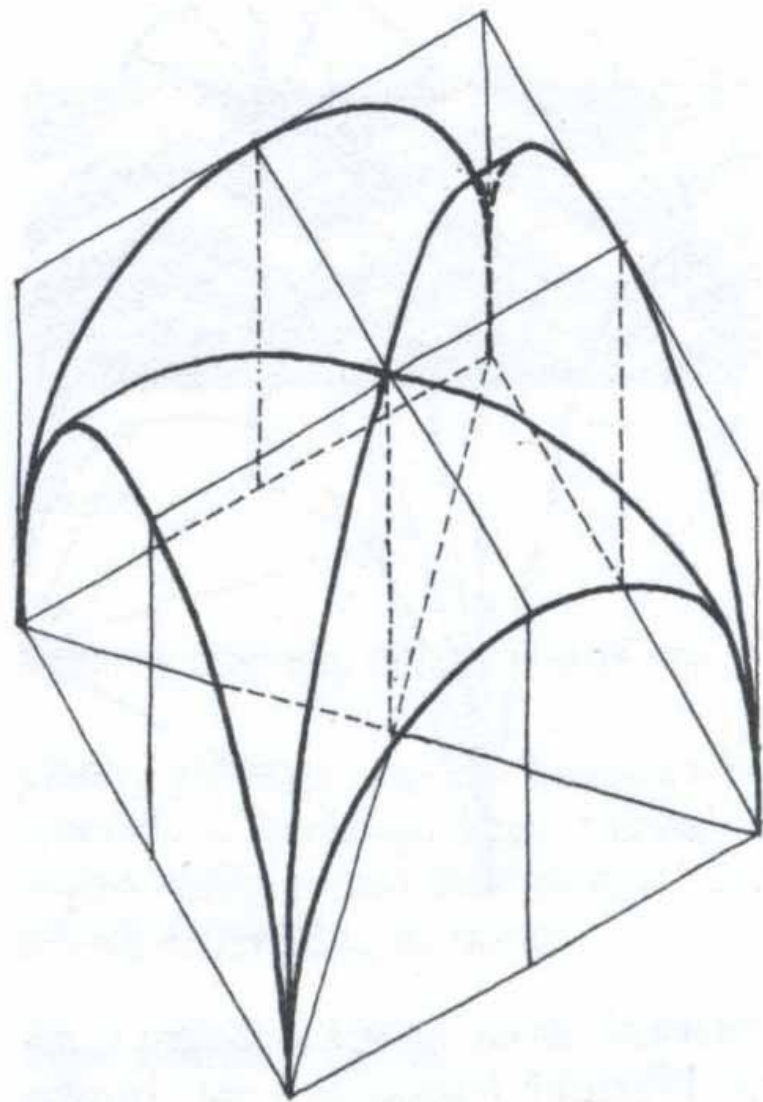

křížová

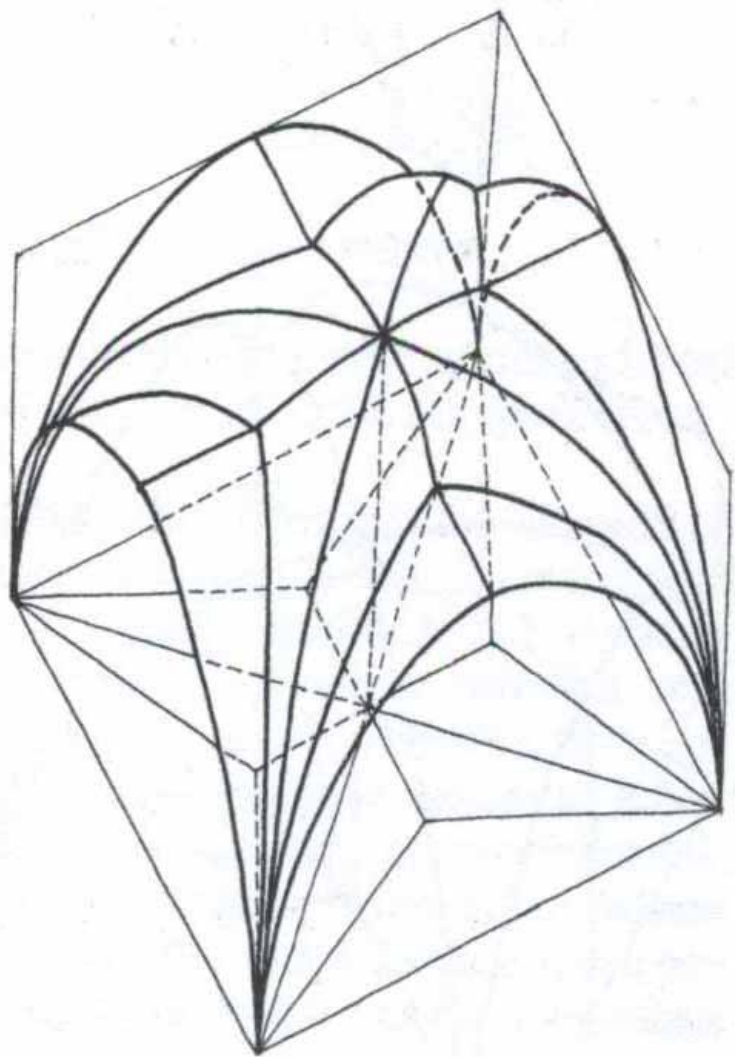

hvězdicová

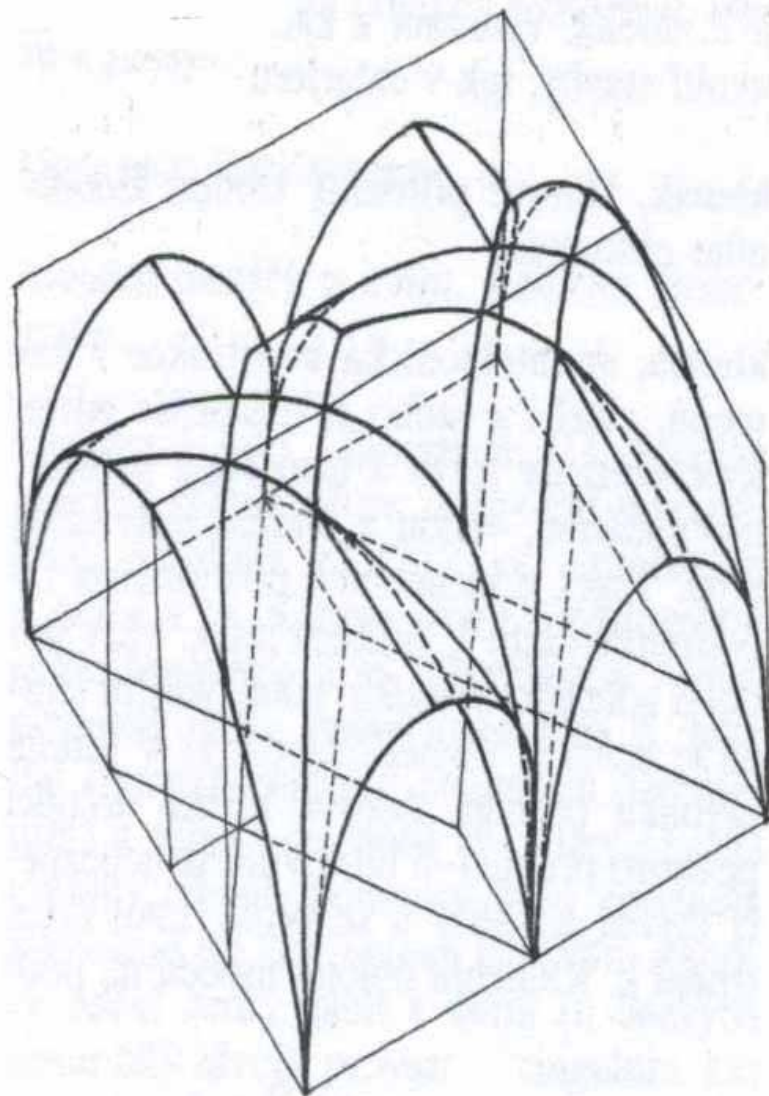

síťová



Kostel sv. Víta,
Český Krumlov

1407–1439

hvězdicová klenba

Petr Parléř

Katedrála sv. Víta,
Praha-Hradčany

1344–1386

síťová klenba

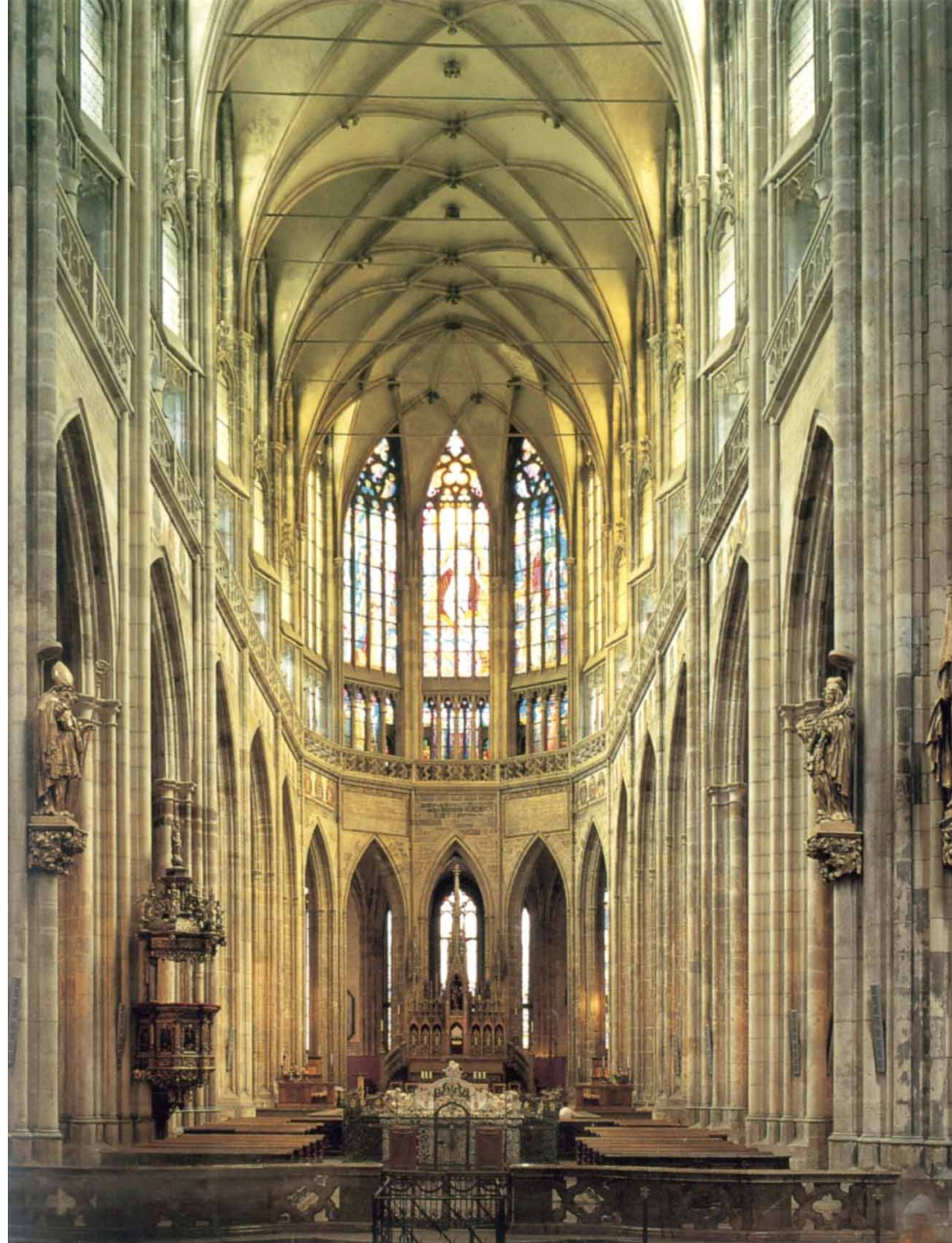

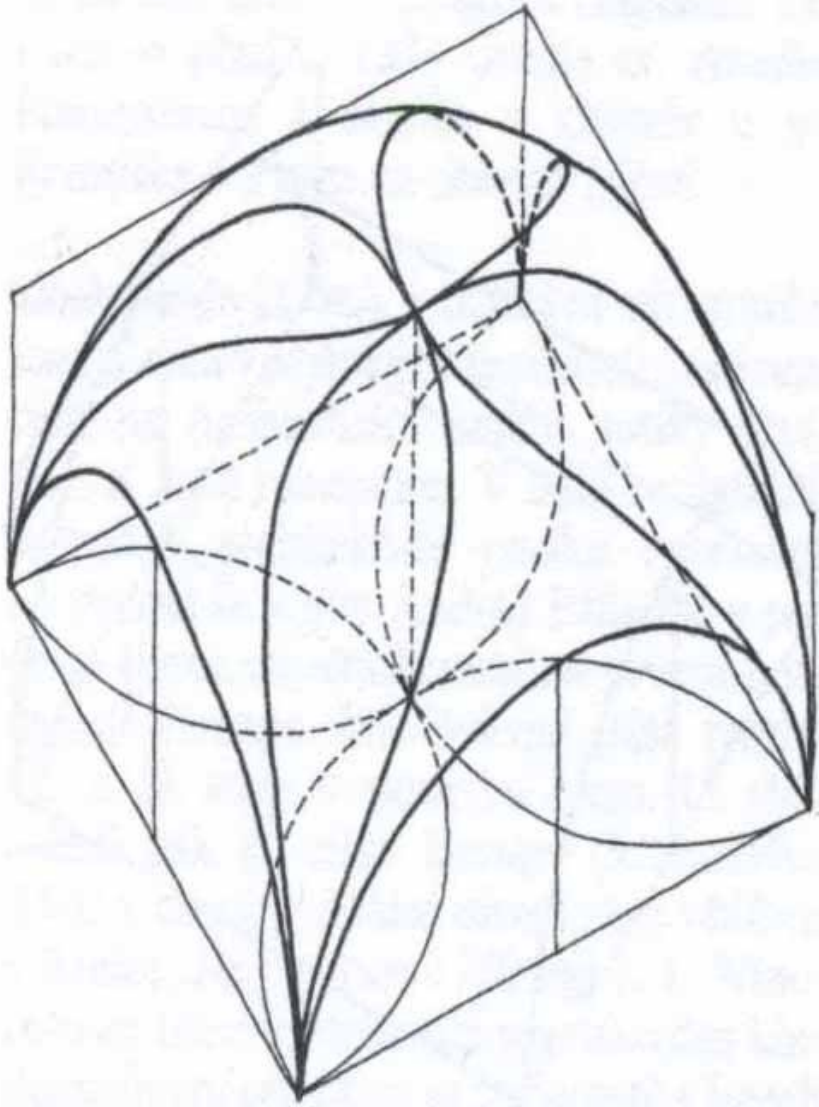

kroužená

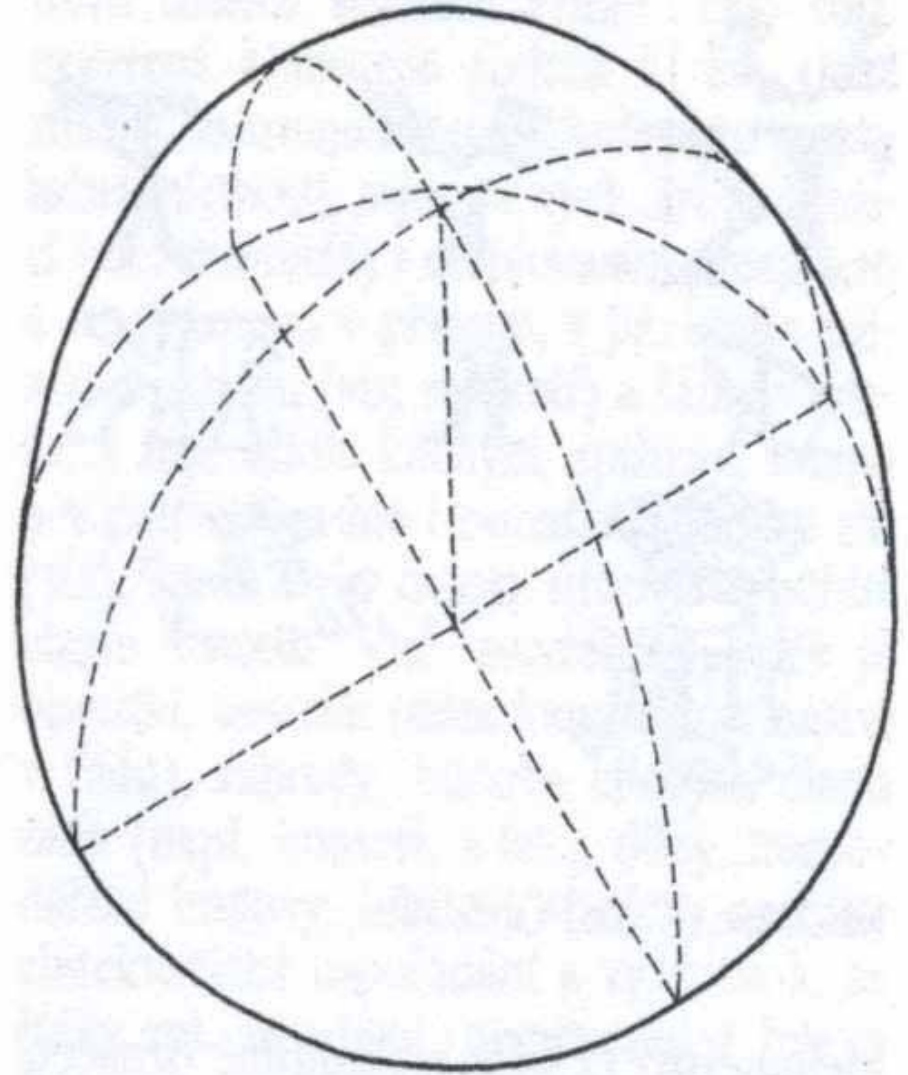

kopule/kupole



Benedikt Rejt

Vladislavský sál,
Praha-Hradčany

1493–1502

kroužená klenba

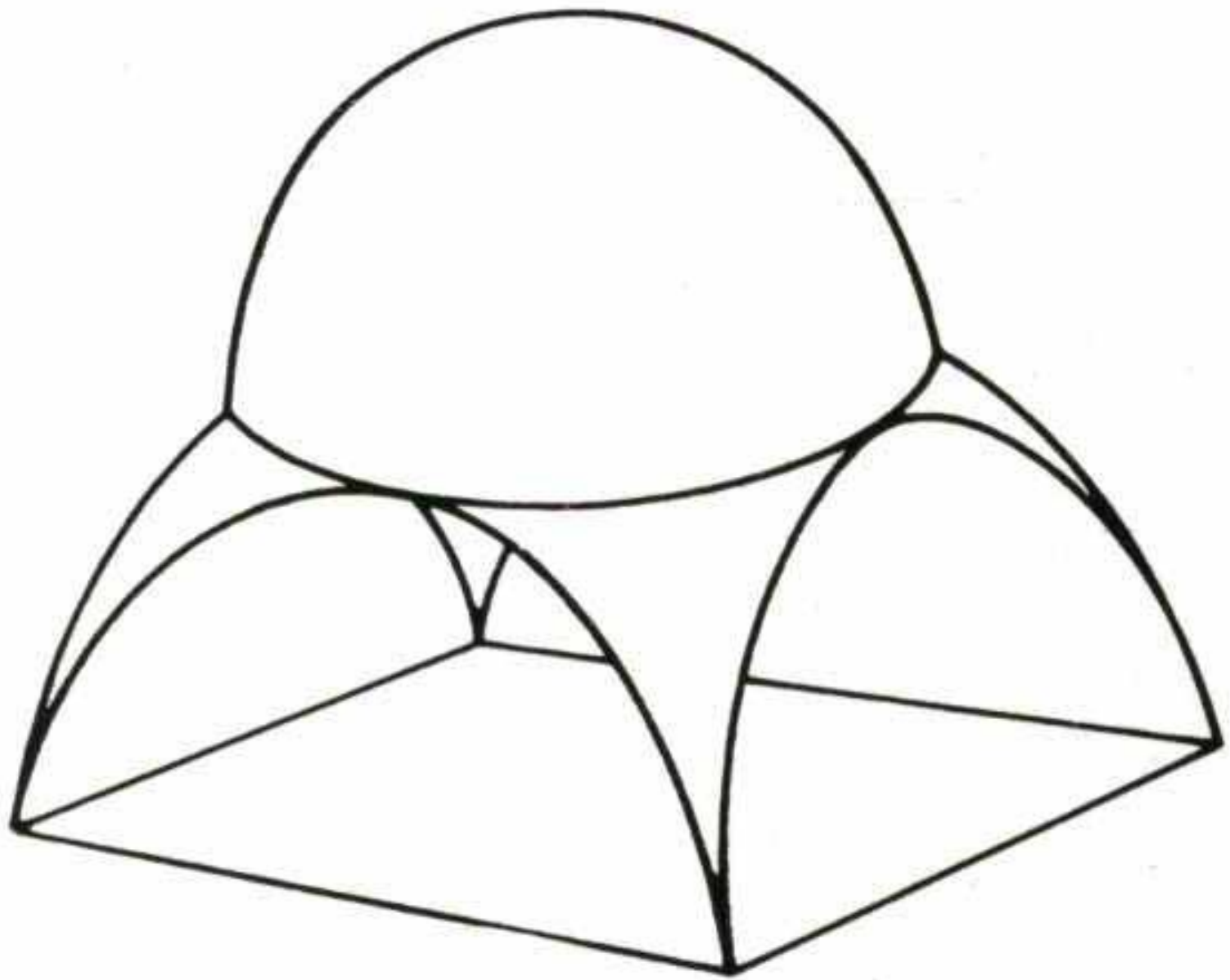

kupole na pandantivech

Michelangelo
Buonarroti
a Giacomo
della Porta

Kupole baziliky
sv. Petra,
Vatikán
(1547 a 1585)

tambur



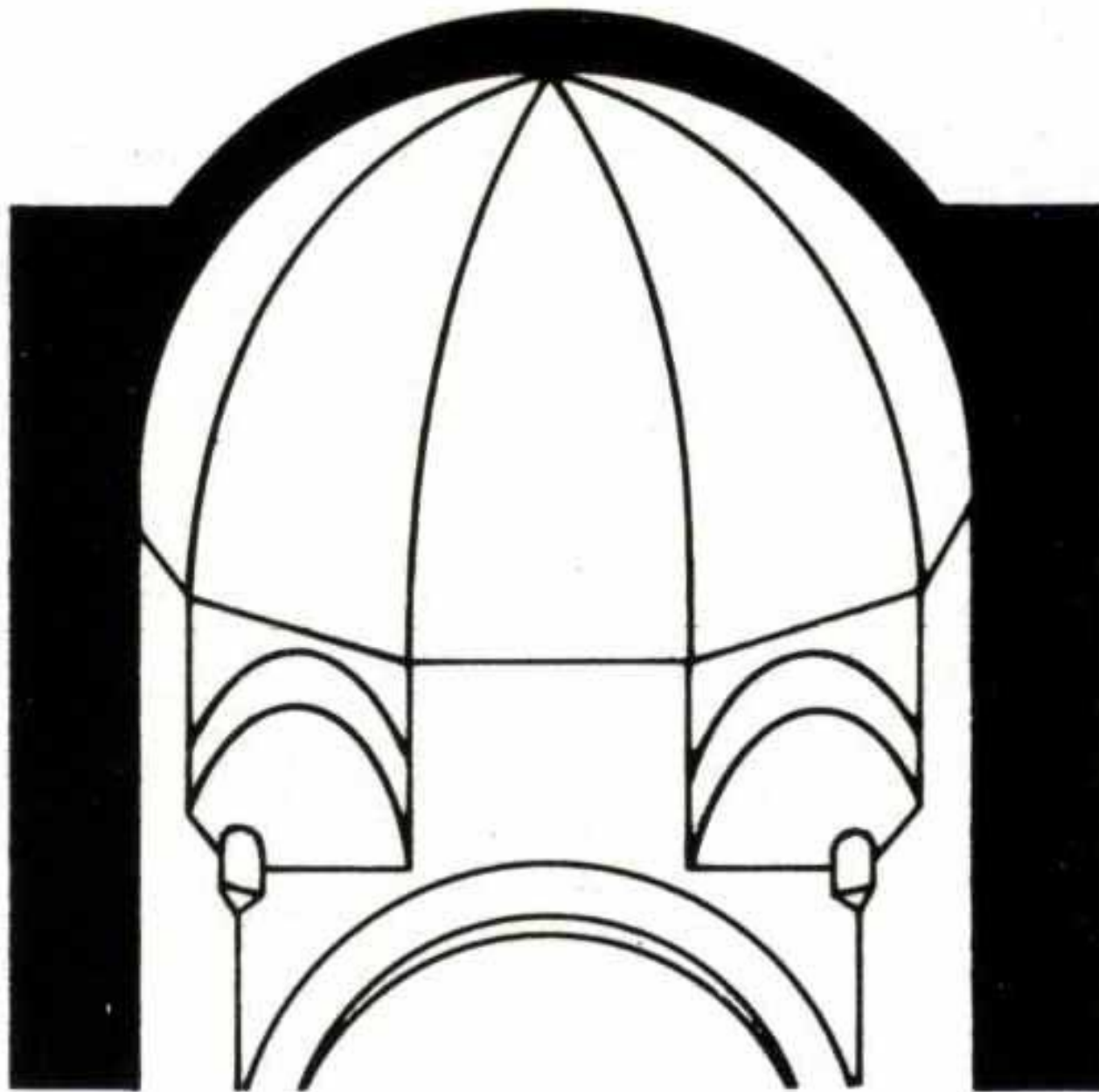

kupole na trompech



Cluny III

1088–1131



Dům čp. 46, Slavonice (kol. 1550)
sklípková klenba

opěrný systém

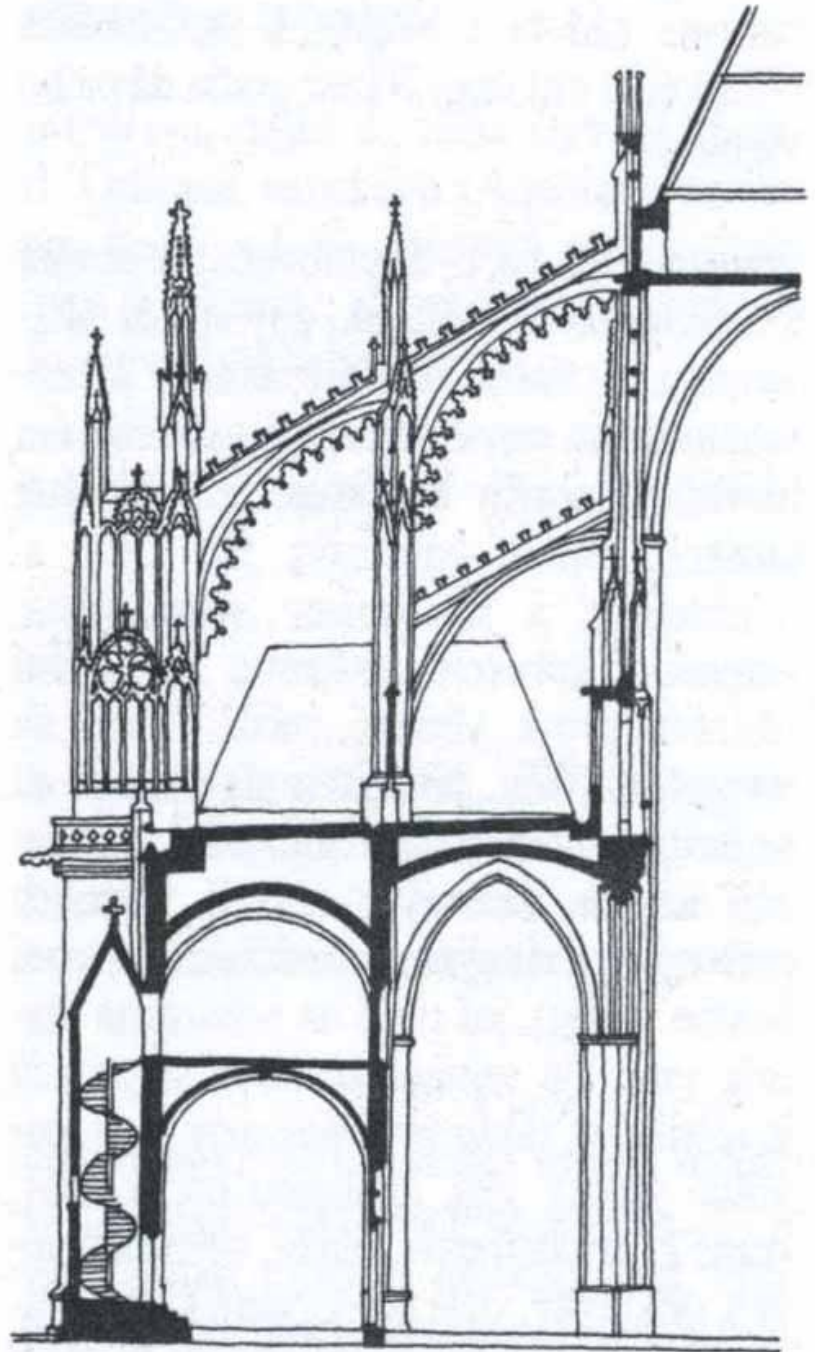

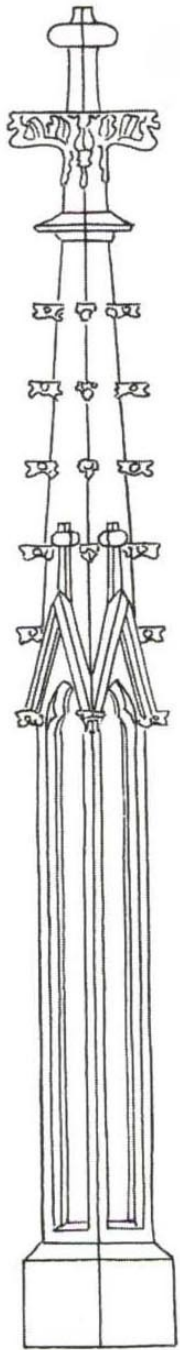

fiála

kraby

kytka

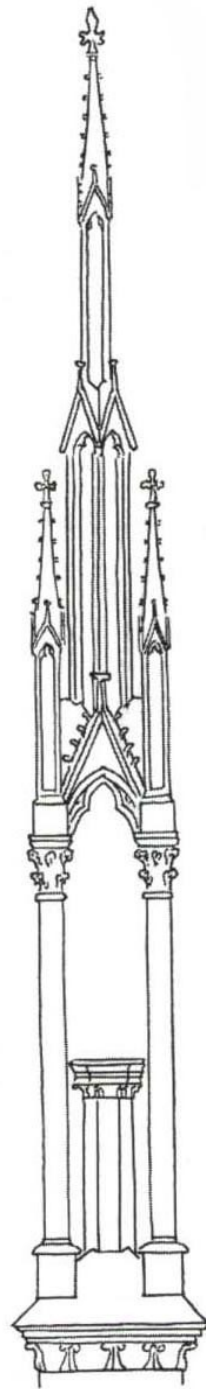

tabernákl

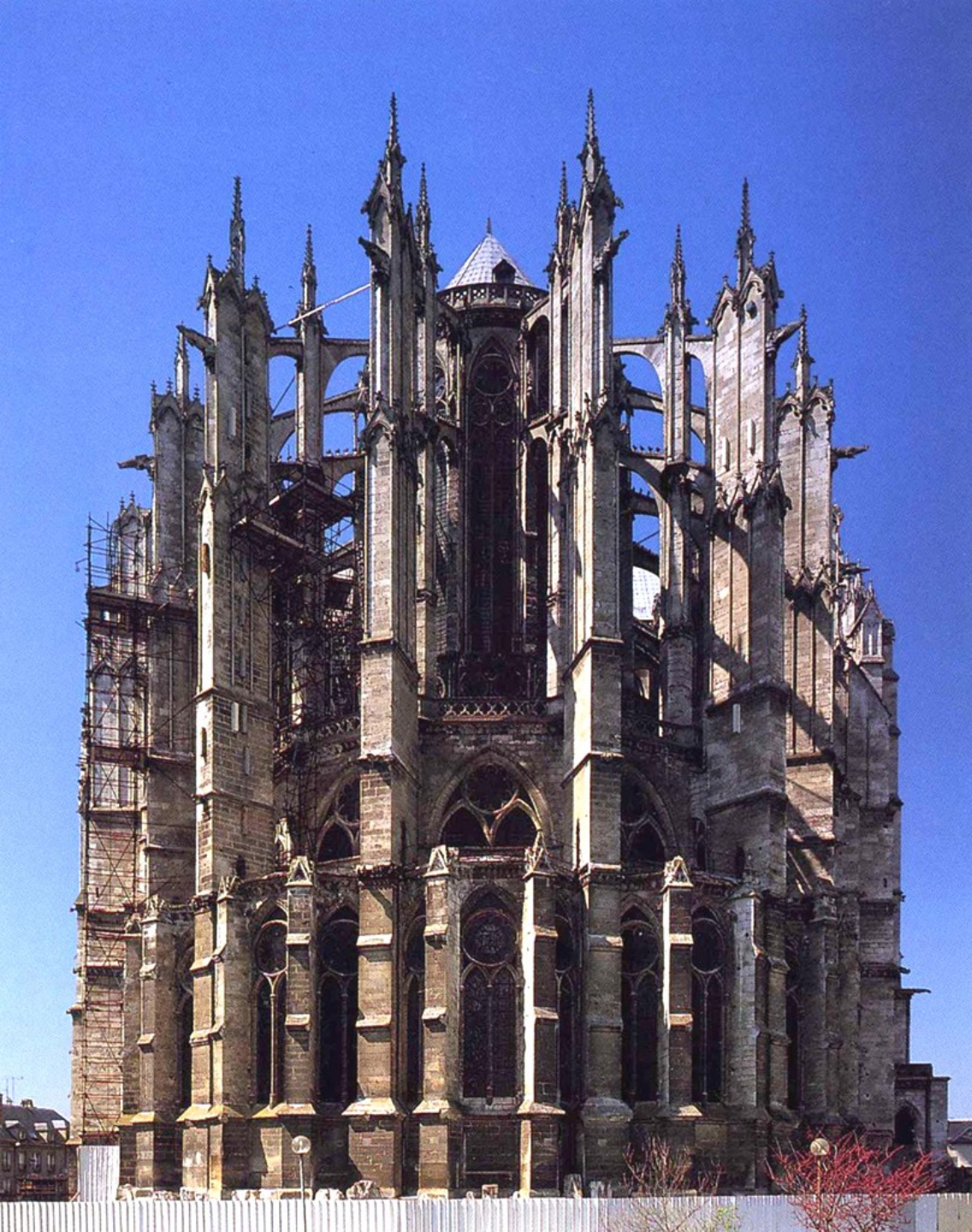

Saint-Pierre,
Beauvais

1225/1284

svazkový pilíř

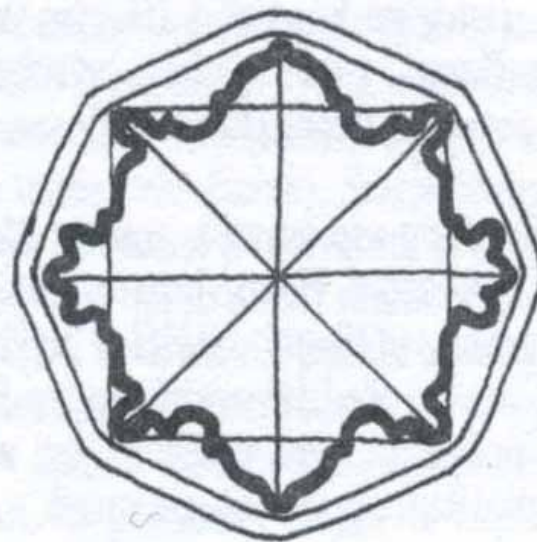
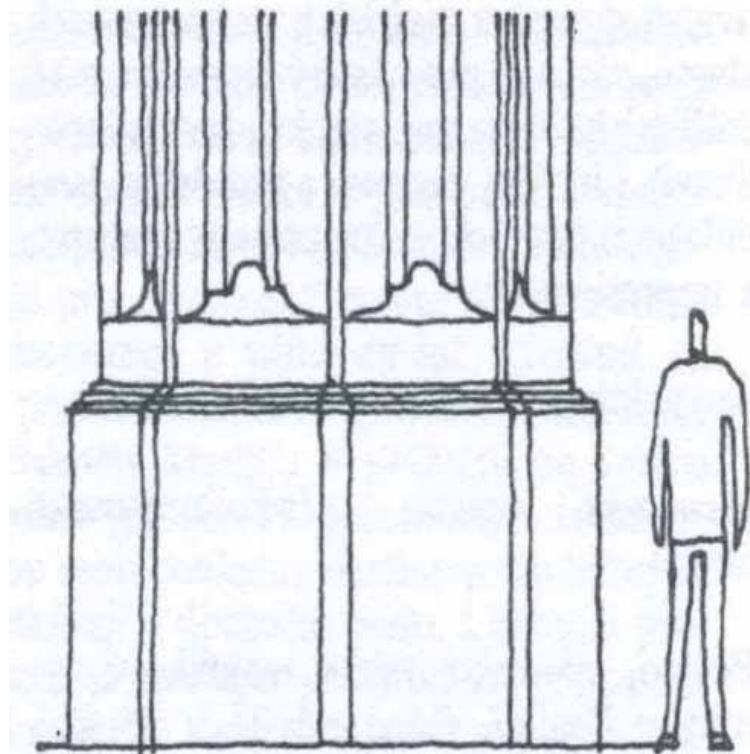

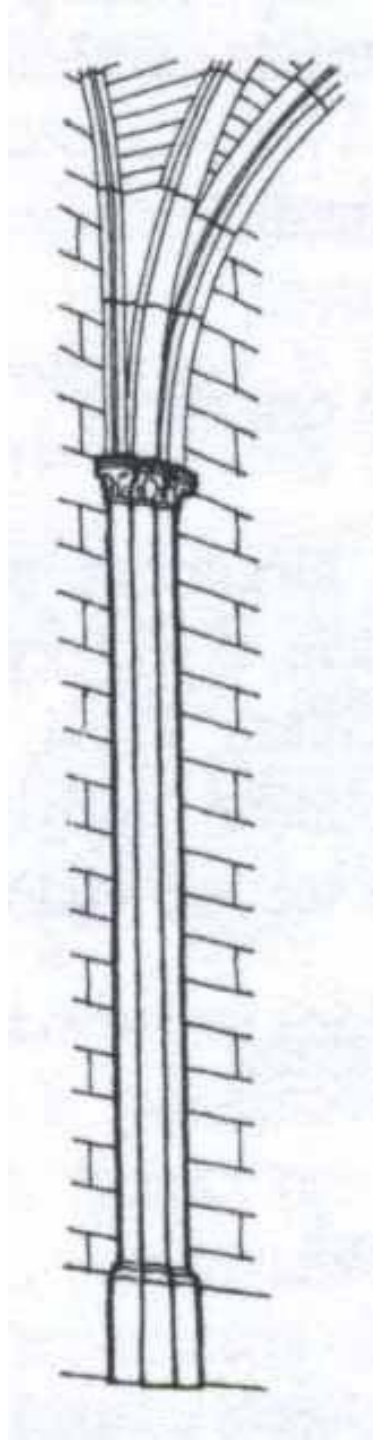

přípora

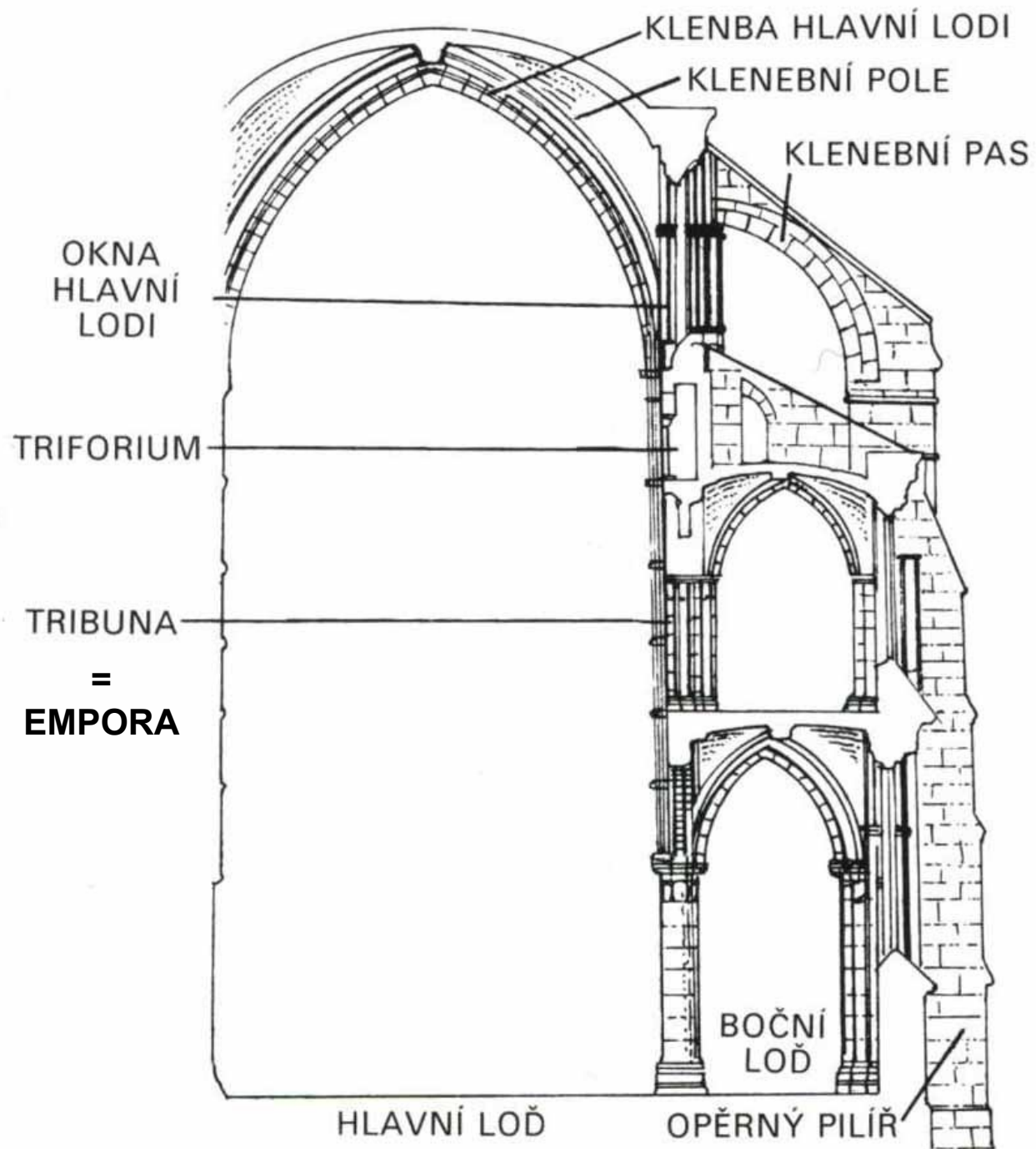

Saint-Gervais-
et-Protais,
Soissons

1180–1190





Kostel
sv. Trojice,
Kutná Hora

před 1420

konzola

Notre-Dame, Chartres

západní průčelí,
střední portál
1145–1155

tympanon

archivolty

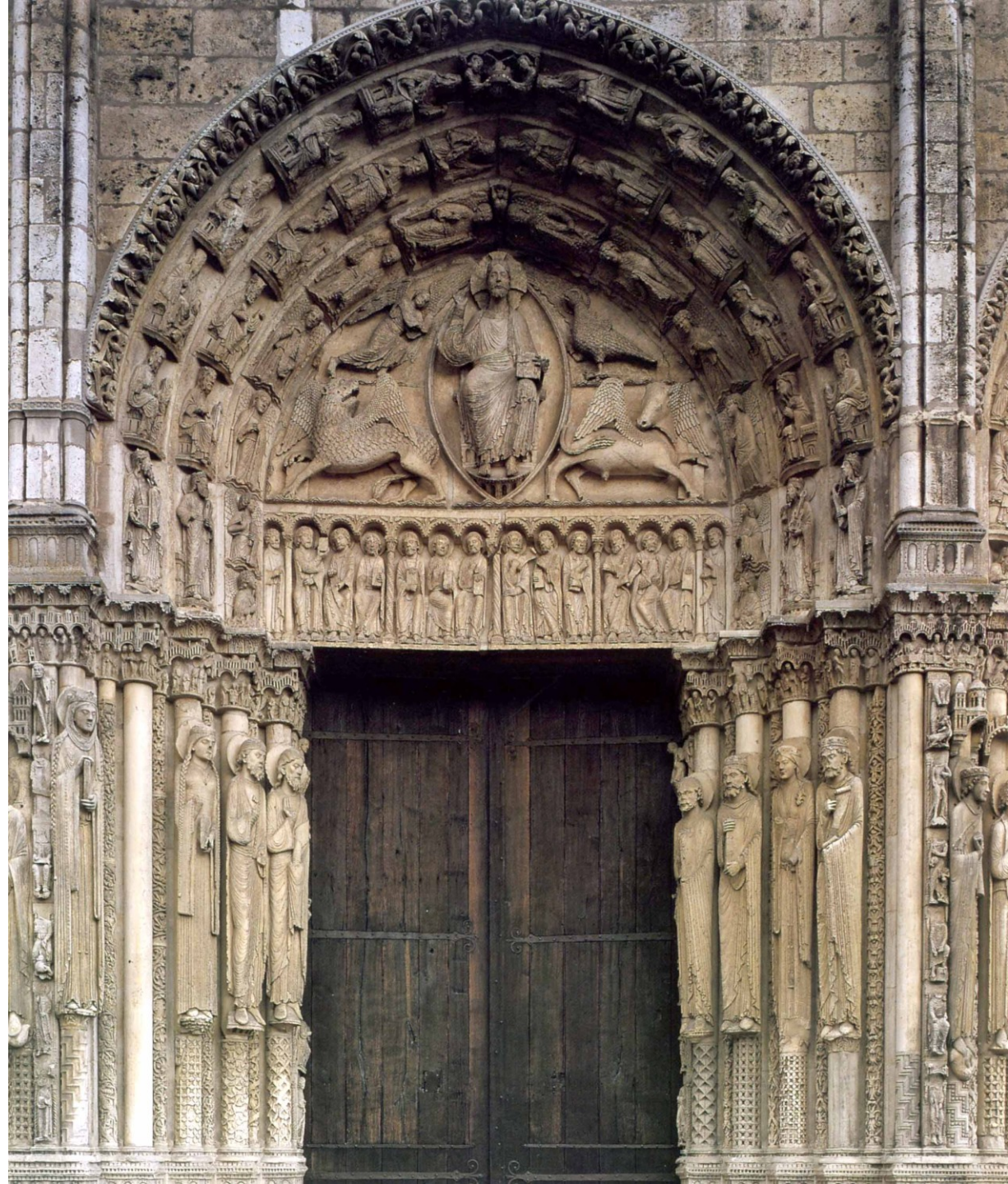

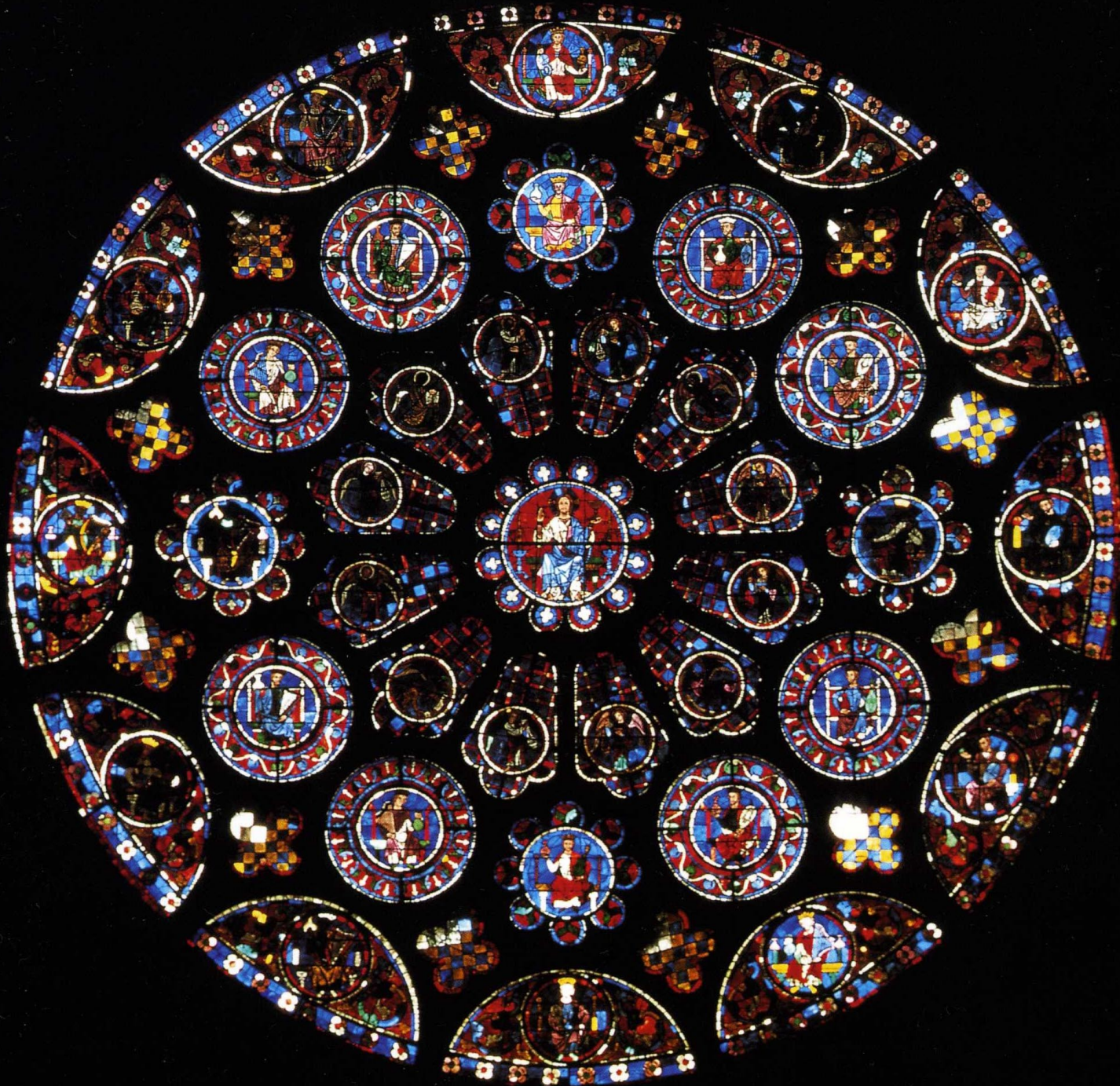

Notre-
Dame,
Chartres

kol. 1200

rozeta

kružba

jeptiška

nosy

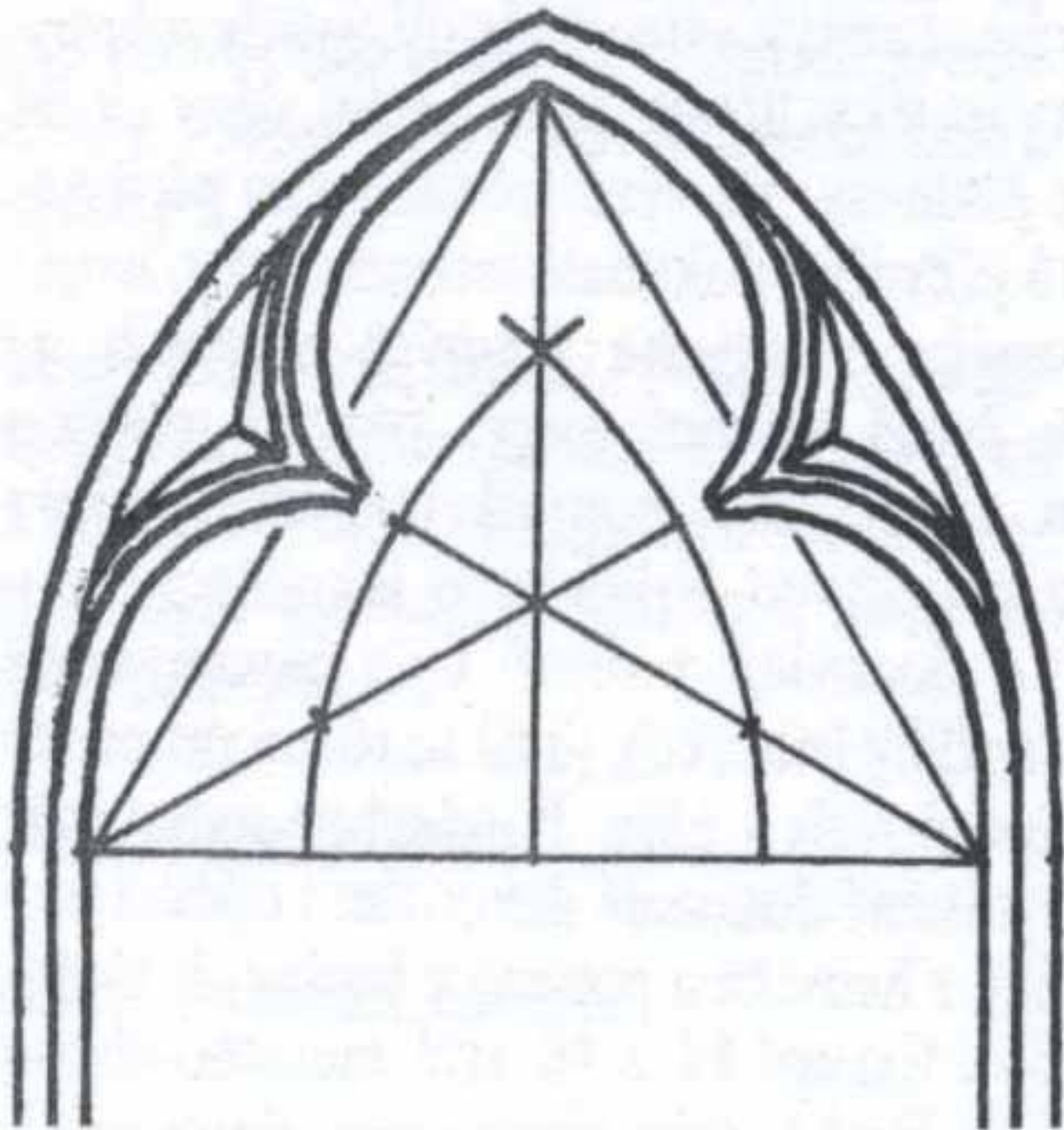



Petr Parlér

Kostel
sv. Bartoloměje,
Kolín nad Labem

1360–1378

*plaménková
kružba*

vimperk

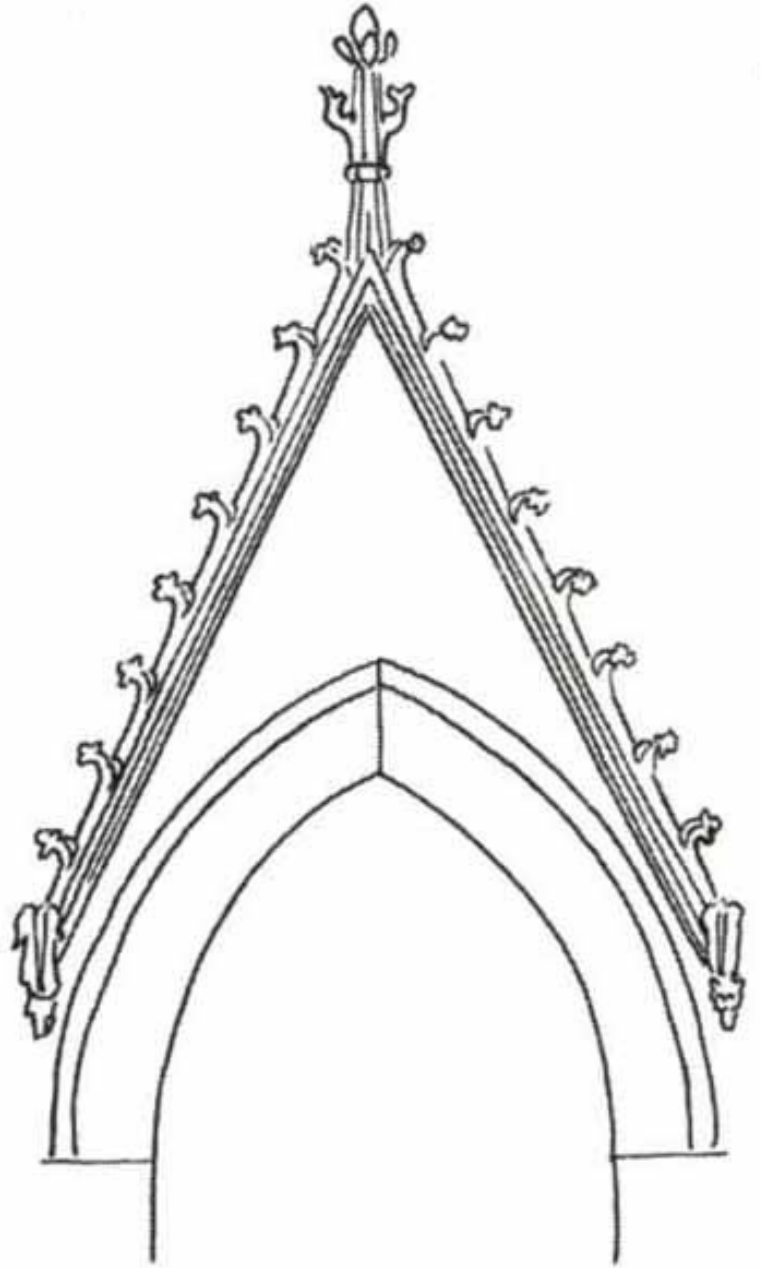



Notre-Dame,
Reims

po 1254