



PA152: Efficient Use of DB
5. Hashing

Vlastislav Dohnal

Outline

- Hash index
- Bitmap index
- Multi-attribute indexes
- Grid index

Hashing – concept

- Key-to-address transformation
 - A function returning an address for an input key value

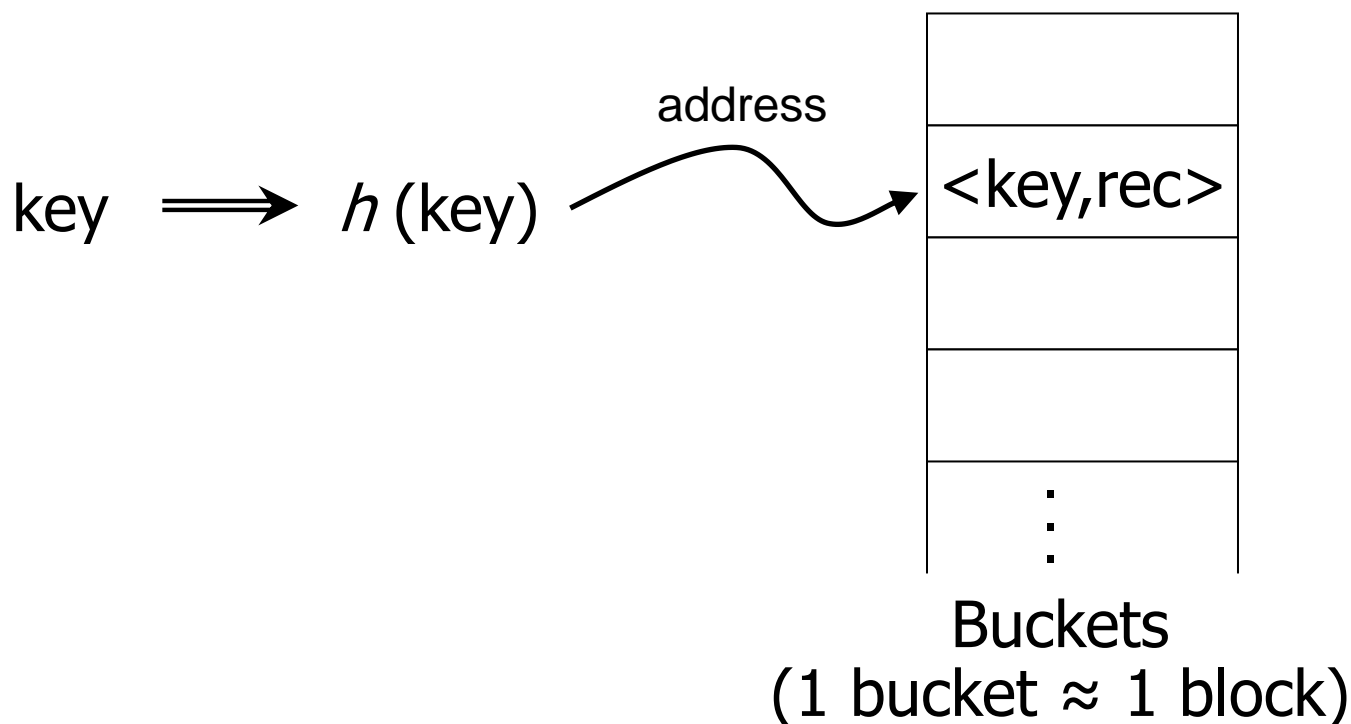

Alternatives

■ Direct addressing

□ Typically address of a block

- Good for hashed file

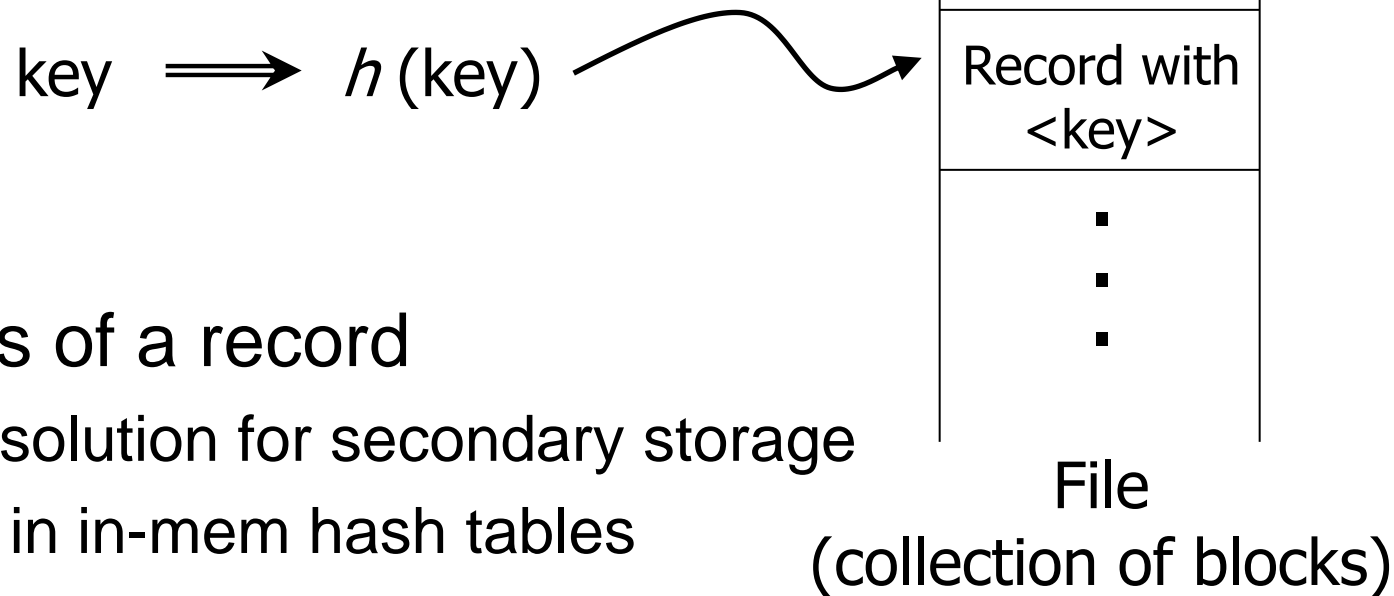

□ Address of a record

- Rare solution for secondary storage
- Used in in-mem hash tables

Alternatives

■ Indirect addressing

- Used in secondary indexes
- Has overhead

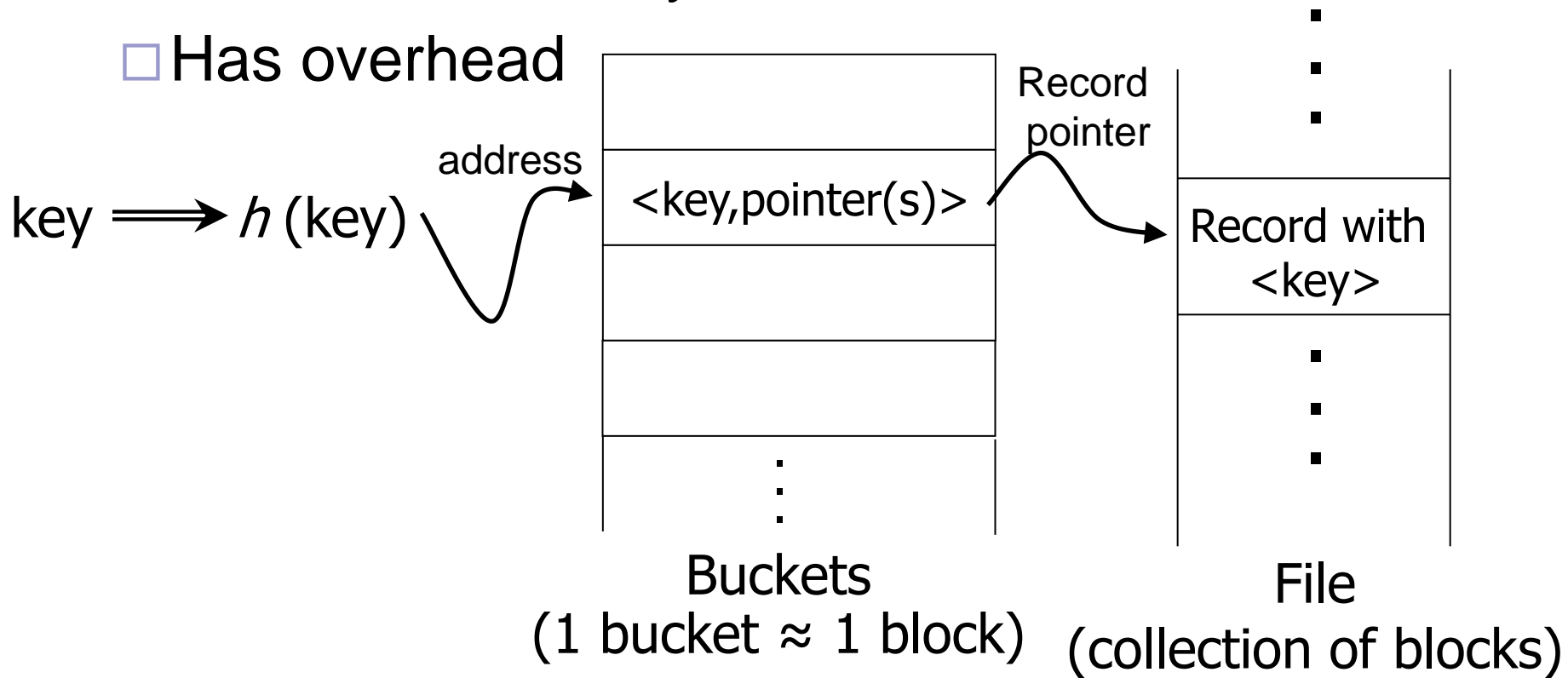

Hash Function – Examples

- Key value as a byte-array
 - n bytes
- Address space
 - B buckets
- Hash function $h(x_0x_1\dots x_{n-1})$
 - $(x_0+x_1+\dots+x_{n-1}) \bmod B$
 - $(x_0*31^{n-1}+x_1*31^{n-2}+\dots+x_{n-1}) \bmod B$
 - Applicable to variable-length values

Hash Function

- Properties:

- Uniform

- Equal occupation of all buckets

- Random

- Low correlation between its input and output

- „Big science“ → special literature

- Good hash function must be uniform

- Locality-sensitive hashing

- ...

Address Space

- Collection of buckets
- Bucket
 - Capacity larger than 1 record
 - Sort the keys?
 - Yes, if access should be faster
 - No, if updates are frequent

Terminology

- Hash function

- Collisions

- Another record present on the returned address

- No problem if more keys/recs can be stored

- Overflows

- Bucket capacity is exhausted

- Overflow blocks

- **Static vs. dynamic** hashing

- Address space cardinality can be modified

Static Hashing: Collision Solutions

- Closed addressing (= open hashing)
 - Returned address is fixed
 - On overflow, allocate a new block (overflow area)
 - Chaining overflow blocks
 - Used in secondary memory indexes/files
- Open addressing (= closed hashing)
 - Collision function is introduced
 - Linear, quadratic, double-hashing
 - Used in in-mem hash tables

Example

- Static closed addressing
 - Collisions handled by overflow blocks
 - Block capacity = 2 keys

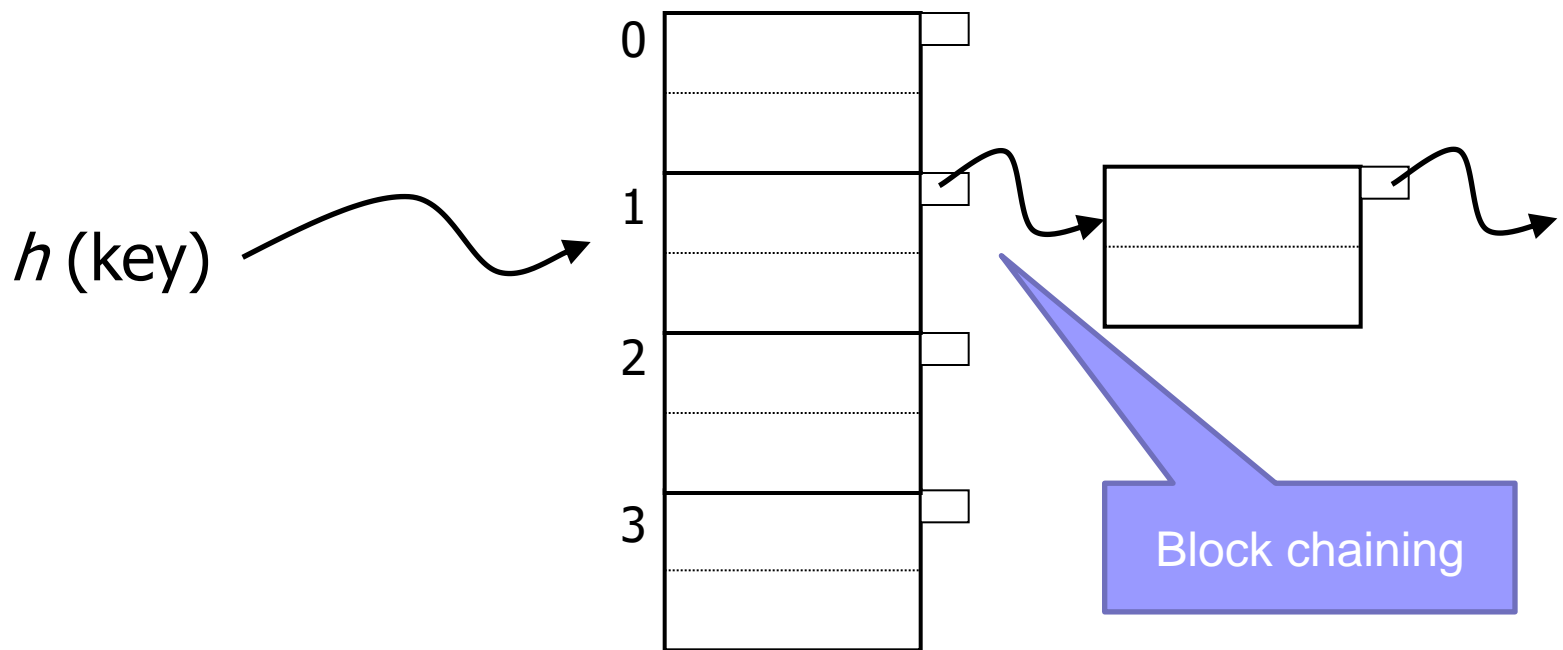

Example: Insert

- $h(„b“) = 2$

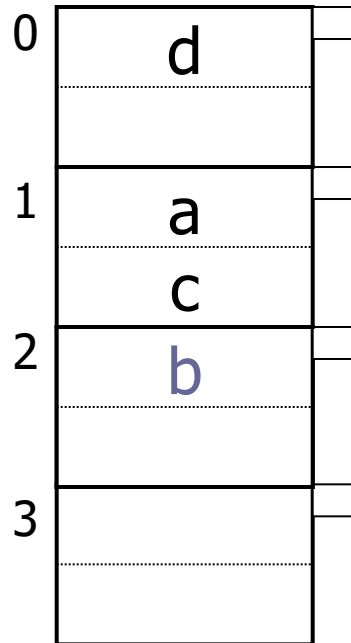

Example: Insert

- $h(„e“) = 1$

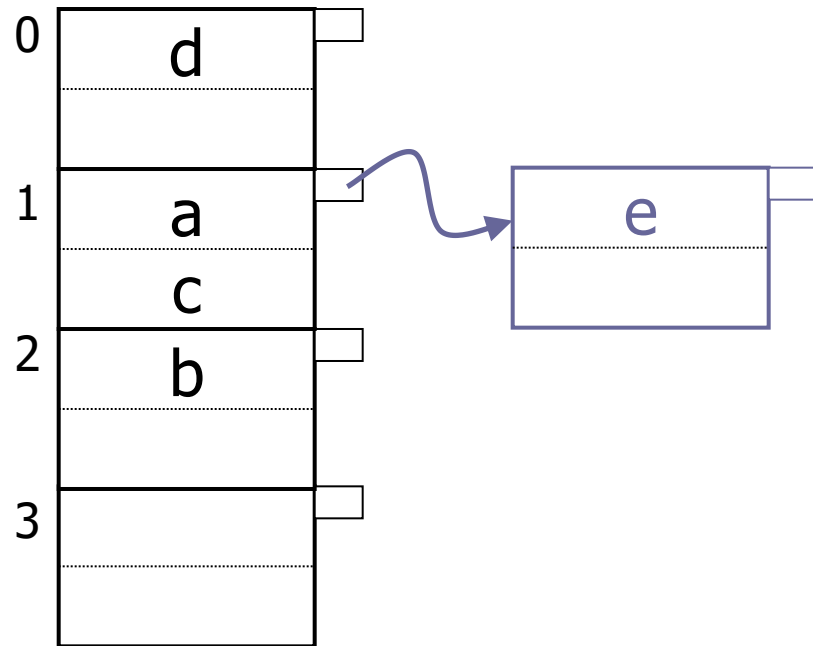

Example: Deletion

- Free overflow blocks up
- Delete „b”

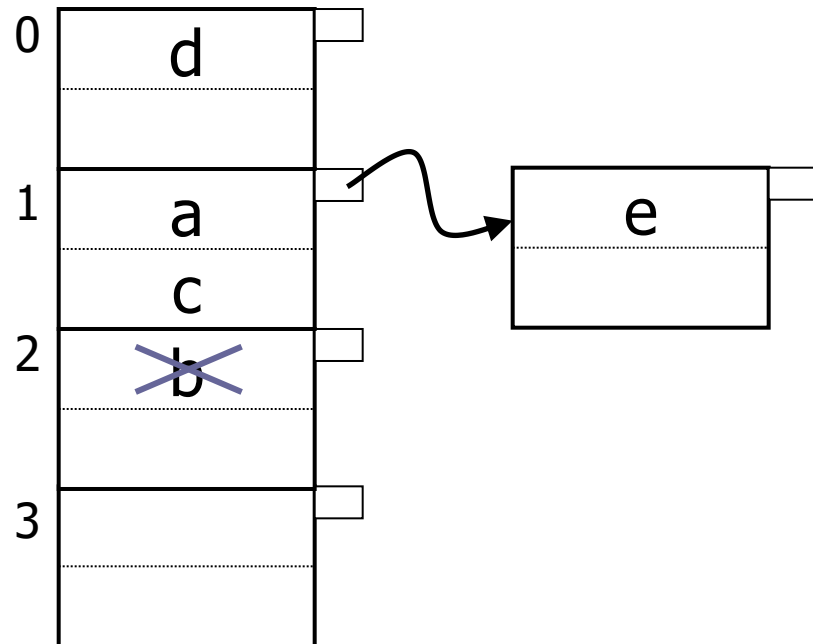

Example: Deletion

- Free overflow blocks up
- Delete „c”

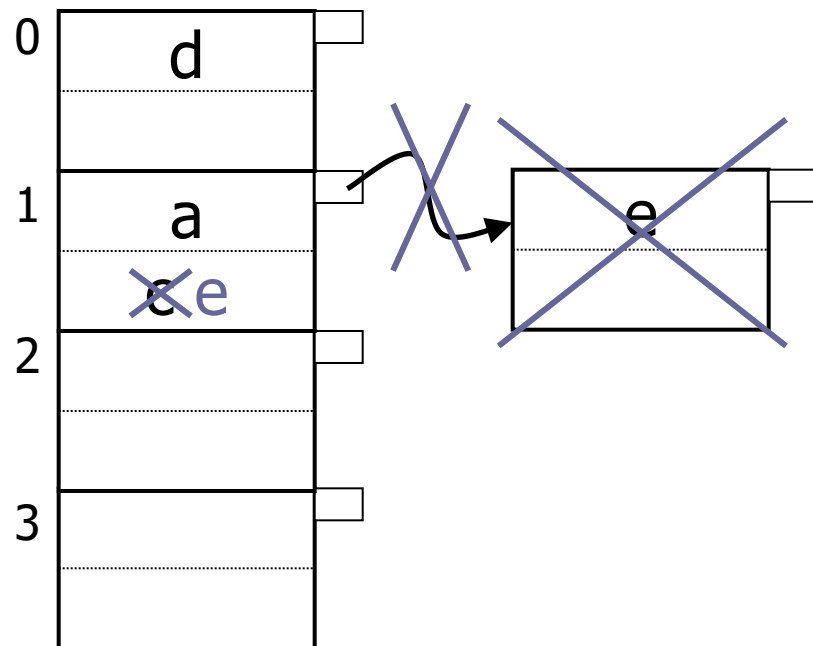

Example: Deletion

- Free overflow blocks up
- Delete „a”

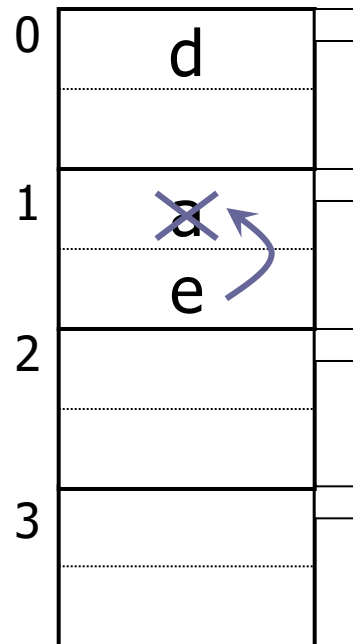

Rule of thumb

- Keep space utilization btw. 50% and 80%
 - Utilization = $\# \text{ stored keys} / \text{max. capacity}$ (in keys)
 - $< 50\%$ \rightarrow wasting space
 - $\geq 80\%$ \rightarrow too many collisions
 - Overflow areas degrade searching and insertion performance

Dynamic Data

- Static hashing

- Overflows → reorganization

- i.e., designing a new hash function

- **Dynamic hashing**

- Extendible

- Linear

Extendible Hashing

■ Idea:

- Use top i of b bits output by hash function
- Indirection added – directory
 - Size is power of 2

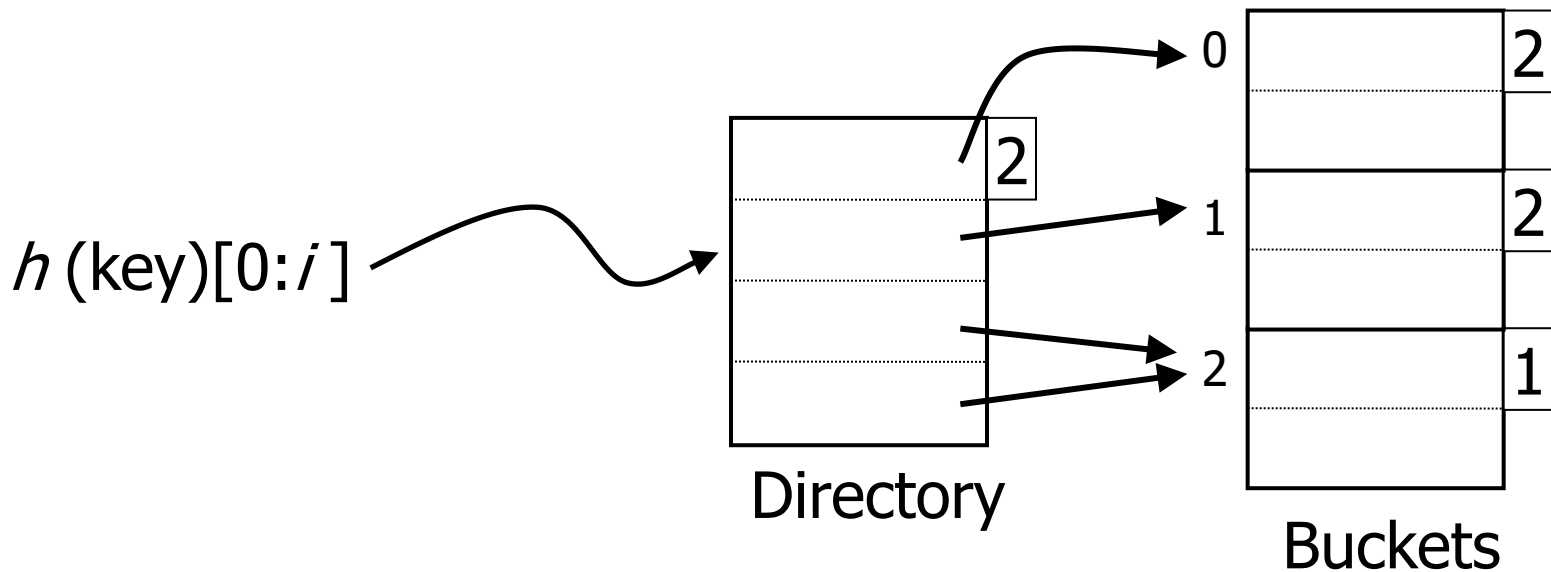

Extendible Hashing: Insertion

- Example: $h(x) = x$, i.e., identity
- Locate a bucket
 - is free space available?
 - Yes \rightarrow insert;
 - No \rightarrow so split the bucket & redistribute its content

■ Insert

- 0001
- 1010

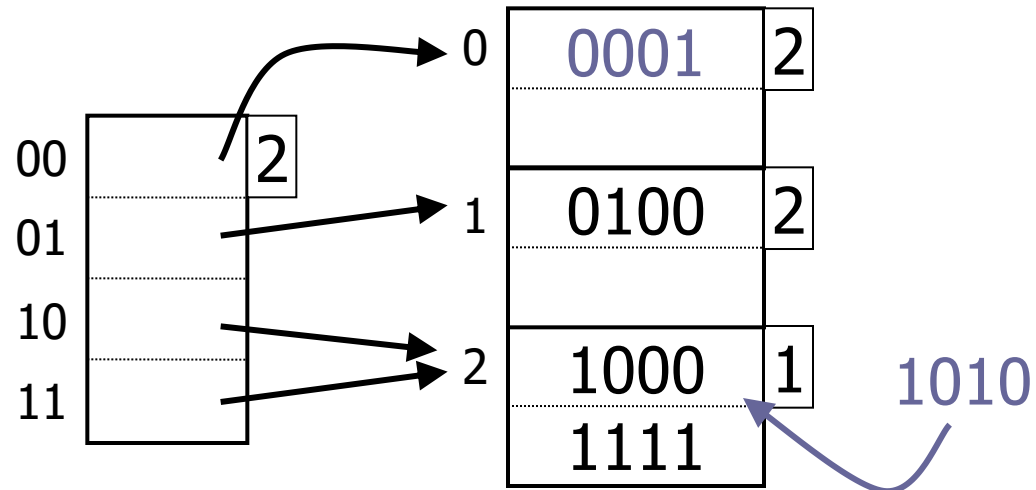

Extendible Hashing: Insertion

- Insert 1010
 - Split bucket

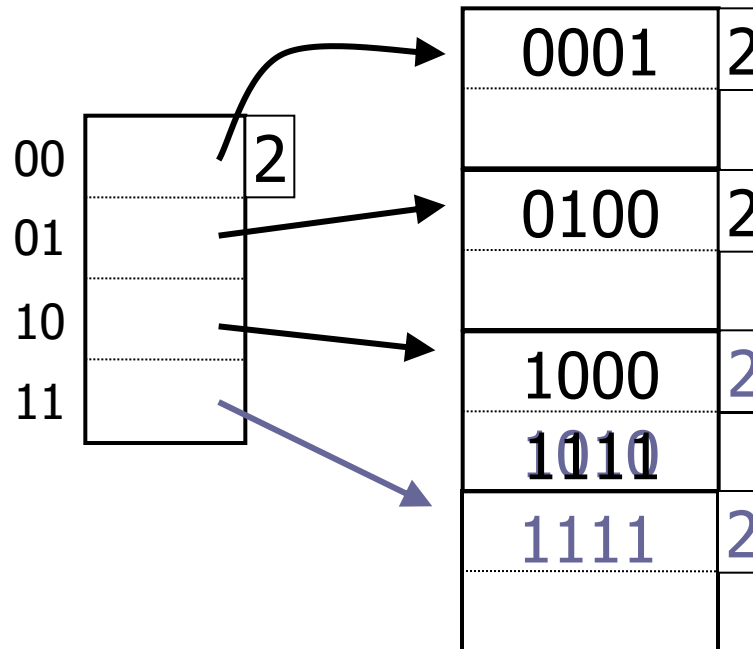

Extendible Hashing: Insertion

- Insert 1011

- Directory is full → double it (use one more bit)

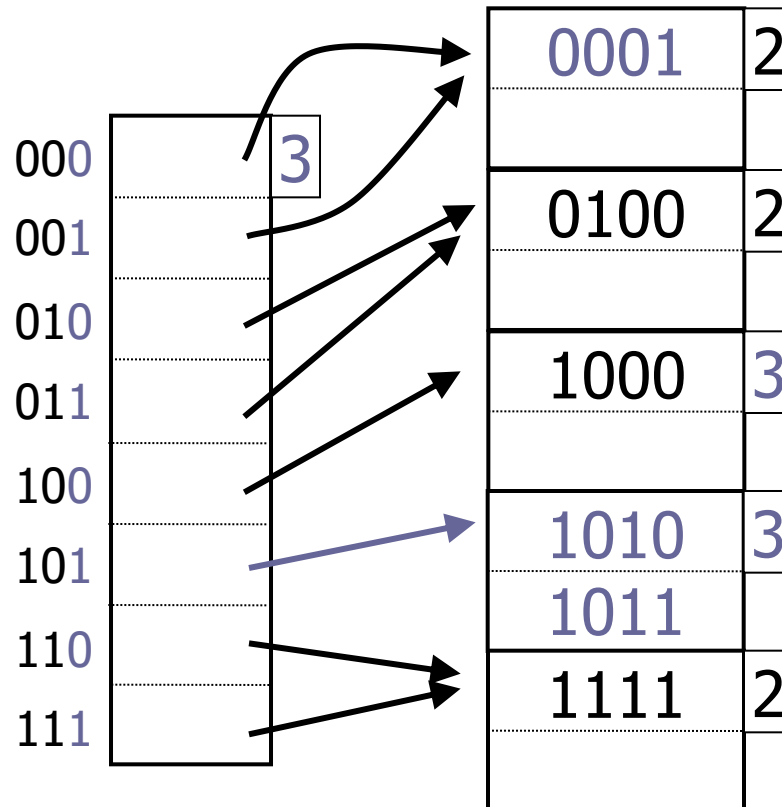

Extendible Hashing: Deletion

- Delete keys
 - Delete key
 - Bucket gets empty
 - No operation → assume new data arriving
 - Merge neighboring buckets
 - Of the same prefix (shorted by one bit)
 - Directory can shrink too

Extendible Hashing: Summary

■ Advantages (over static hashing)

- Handles growing files
- Wasting less space
- Local reorganization

■ Disadvantages

- Indirection
 - Not bad if directory in memory
- Directory doubles
 - May not fit in memory
 - Number of buckets grows linearly

Linear Hashing

■ Idea:

- Use i low order bits of address (of b bits)
- No directory
- File grows linearly

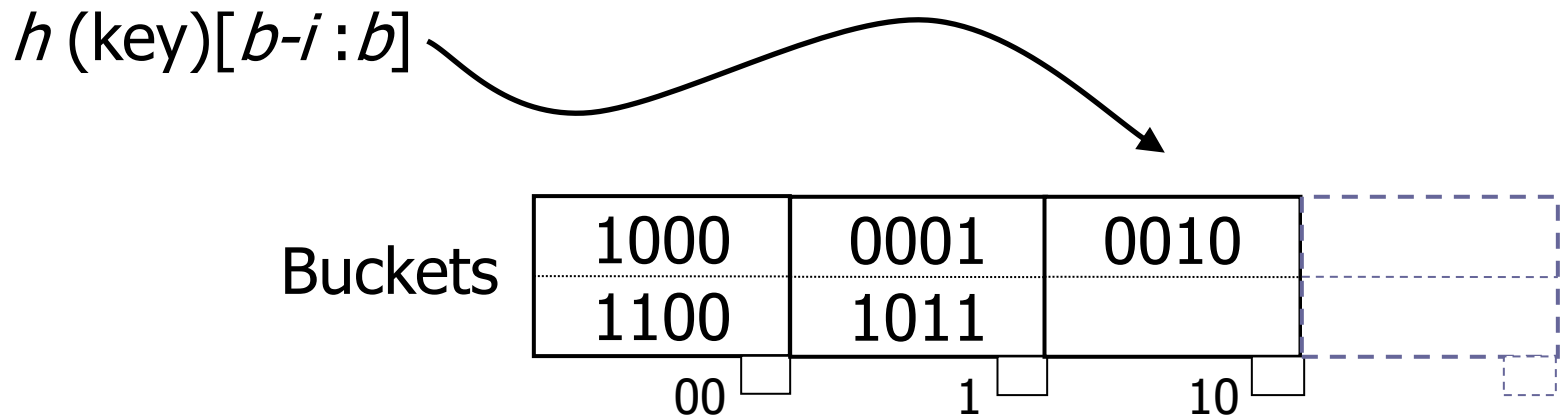

Linear Hashing: Insertion

■ Parameters:

- b – length of hash address
- i – suffix length $\Rightarrow h(k)[b-i:b]$
- n – number of allocated buckets

■ Insert 1011_b

□ $h(1011_b)[2:4] = 11_b = m$

- If $m < n$, insert into bucket m
- Otherwise, insert into bucket $m - 2^{i-1}$

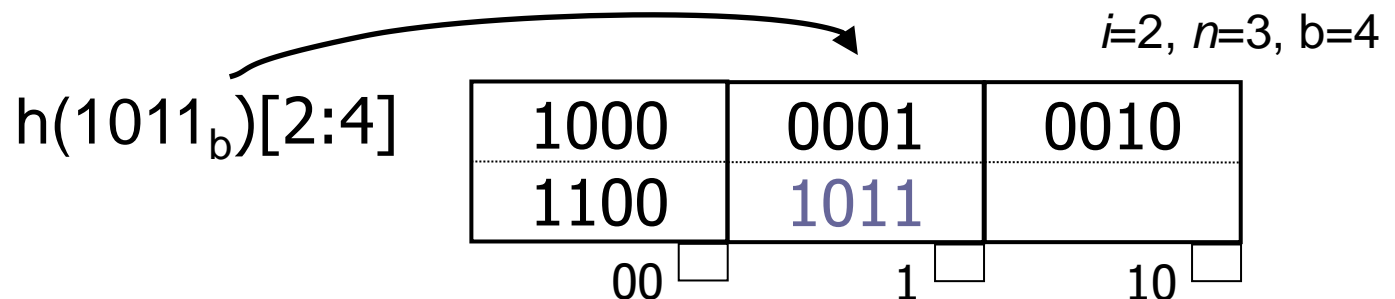

Linear Hashing: Insertion

■ Insert 1001

□ $h(1001)[2:4] = 01$

□ No room \rightarrow create overflow bucket

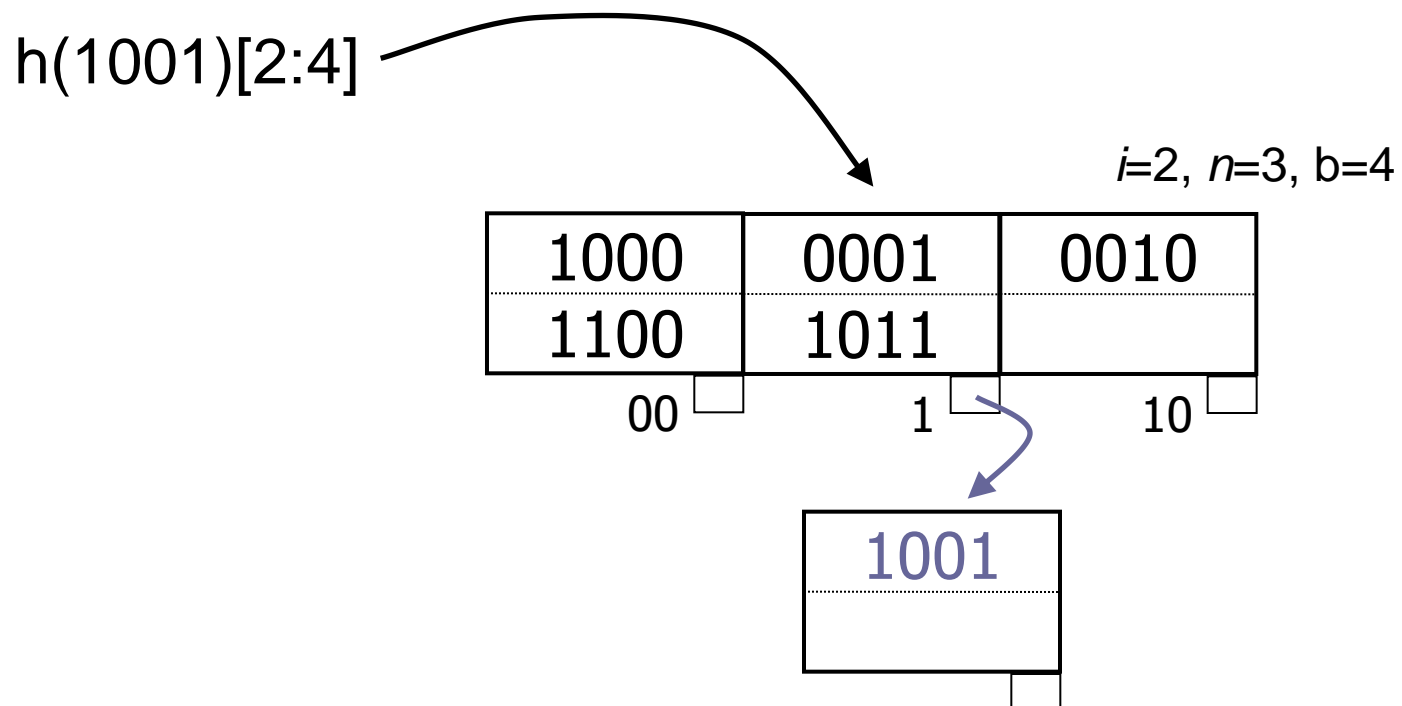

Linear Hashing: Bucket Splitting

- Keep track of bucket utilization

- $>80\%$, then split a bucket (its address is $0abcd\dots z$)

- Add new bucket \rightarrow address is $1abcd\dots z$

- Distribute keys from bucket $0abcd\dots z$ and its overflow to buckets $[01]abcd\dots z$

- This address $(n - 2^{i-1})$ is always split, i.e., $3 - 2^1 = 1$

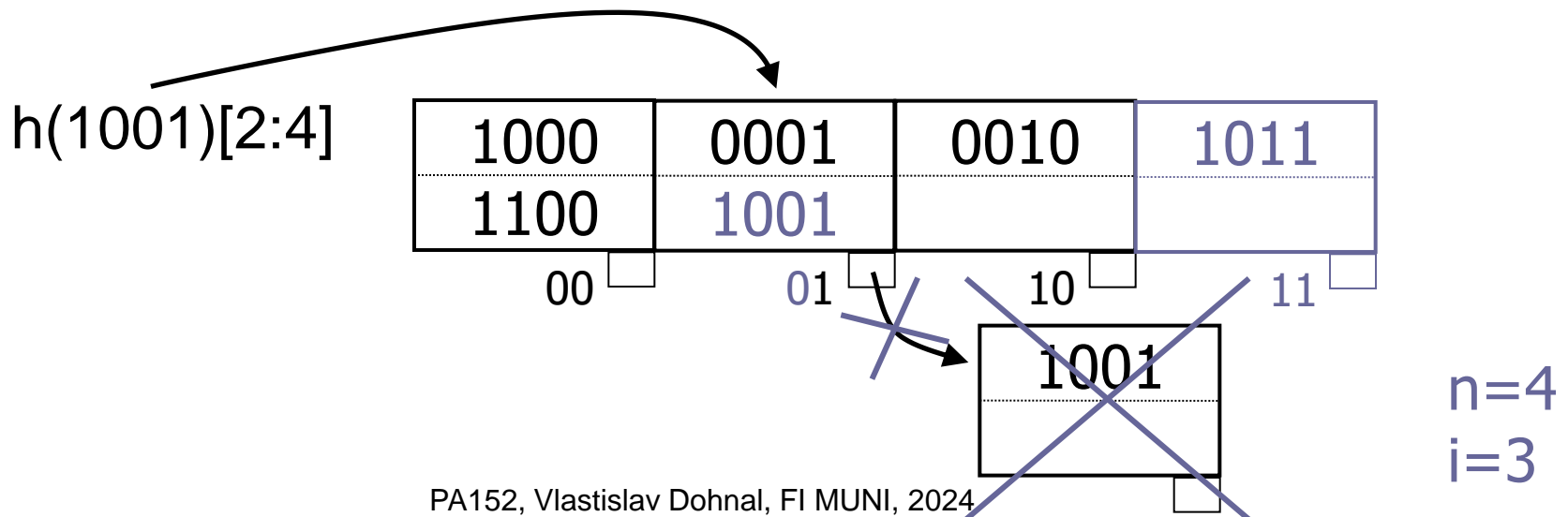

Linear Hashing

■ Inserting new keys

- May lead to overflow buckets

- Utilization exceeding 80%

 - Do the bucket split

 - The bucket being split may differ from the overflowing one!

- After allocating 2^i -th bucket, increment i

 - i.e., the bucket count exceeds $2^i - 1$

Linear Hashing: Summary

- Advantages (over static hashing)
 - Handles growing files
 - Less wasted space
 - Local reorganization
 - No indirection like extendible hashing
- Disadvantages
 - Overflow chains

Linear Hashing: Example

- „Bad“ data

- Last x bits do not distinguish keys

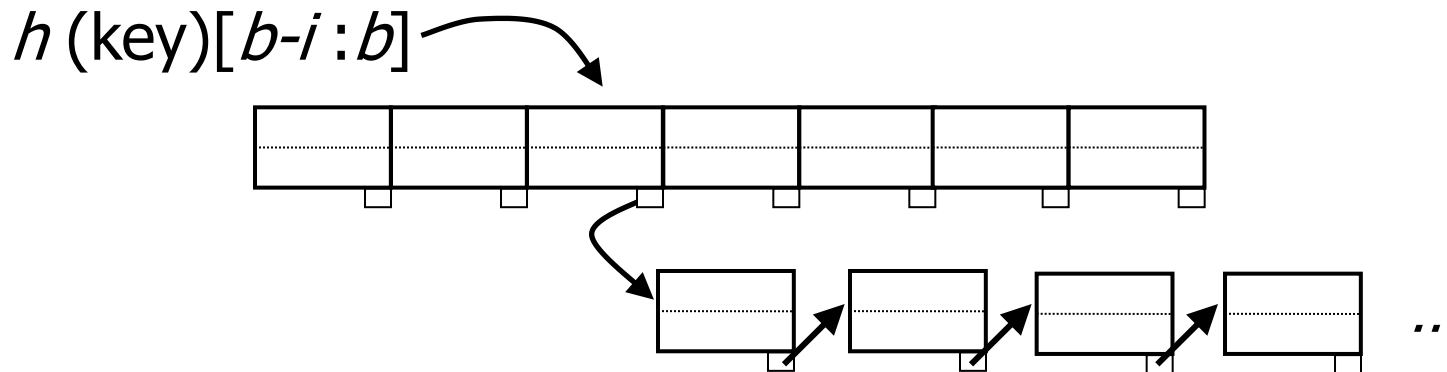

- One bucket “stores” all data; others are empty
 - Utilization is decreased by split
 - → need to track the length of overflow blocks!

Hashing vs. Indexing

■ Hashing

- Good for exact match

SELECT ... WHERE a=5

■ Indexing

- Good for range search

SELECT ... WHERE a>5

■ What if cardinality of ``a'' is low?

Bitmap (raster) index

- Attribute X has got h unique values
- Collection of h bit arrays
 - One array (vector) per value
 - Array length is equal to # records (n)
- Good for attributes with „few“ values
 - Up to 10% of records
- Queries:
 - WHERE $a = 5$ OR $a = 7$

Bitmap index: Example

- Relation $R(F, G)$

F	G
30	foo
30	bar
40	baz
50	foo
40	bar
30	baz
34	foo

- Bitmap index on G

<i>Value</i>	<i>Vector</i>
foo	1001001
bar	0100100
baz	0010010

Bitmap index: Summary

■ Disadvantages

□ Storage demands

- If *key* is the primary key, then
 $n(n + \log_2 n)$ bits

- Many records with the same value (many 1's)
or too many records in general

- Compress to the bit vector of blocks (instead of records)

□ Record updates

- New value → add new array
- New record → extend all arrays

Bitmap index: Summary

■ Advantages

- Fast bit operations (AND, OR)
- Applicable to ``range'' queries
- Easy to combine multiple indexes together
 - which are typically single-attribute indexes

Bitmap index: Compression

- Reduce individual arrays
 - Few 1's, many 0's
 - ends with one
 - trailing zeros are omitted
 - Can be filled up to # records
- Run-Length Encoding (RLE)
 - Split to blocks
 - Sequence of "*i*" zeros followed by *one*
 - Encode "*i*" binary
 - Code for "*i*" :
„number length + number itself“

Bitmap index: RLE

- Example of compression – 24 bits
 - Sequence: 0000 0000 0000 0110 0010 0000
 - 13x zeros, 1x one
 - 0x zero, 1x one
 - 3x zero, 1x one
 - 5x zero followed by nothing... → ignore
 - Binary:
 - $13_d \rightarrow 1101_b$
 - $0_d \rightarrow 0_b$
 - $3_d \rightarrow 11_b$
 - RLE code:
 - Sequence of „blocks“:
 - Binary number length in prefix code, binary number itself
 - Code: 11101101001011

Bitmap index: RLE

- Example of decompression
 - Code 11101101001011
 - Split into block and decompress...
 - Binary number length:
 - bit count (ones followed by one zero)
 - 11101101001011
 - Decoding parts
 - 11101101 → 0000 0000 0000 01
 - 00 → 1
 - 1011 → 0001
 - Resulting sequence:
 - 0000 0000 0000 0110 001
 - Missing trailing zeros filled up to # records

Bitmap index: Operations

- Bit operations

- AND, OR

- RLE strings

- Decompression is easy

- No need to decompress

- More complex implementation, but possible

- AND: sum of “*i*”s in codes must match

- OR: by analogy...

- 11101101001011 OR/AND 1101011101001010

Bitmap index: Implementation

■ Issues for efficient use:

1. Locate bit arrays for the passed key value
2. Having the array, how to get records?
3. Updating records, how to update index?

Bitmap index: Solutions

- Ad 1: (Locate bit arrays for the passed key value)
 - We have a bit array for each key value
 - B⁺-tree for keys
 - Pointers to arrays in leaves
 - Storing bit arrays
 - records of variable length
- Ad 2: (Having the array, how to get records?)
 - Get record r (ordinal number of record)
 - Secondary index for record numbers
 - Array of pointers to records (replacement of bit arrays)
 - List of block occupations in the number of records

Bitmap index: Solutions

- Ad 3: (Updating records, how to update index?)
 - Record numbers fixed (not seq. file / sec. index)
 - Delete record
 - tombstone in file and
 - clear a bit in the corresponding array
 - Insert record
 - append to end of file (a new record number)
 - append bit 1 to the corresponding bit array
 - if not existing, create new one

Bitmap index: Solutions

- Ad 3: (Updating records, how to update index?)
 - Record numbers are not fixed
 - Reorganize all arrays
 - i.e., remove one bit from each array
 - Update array of pointers to records
 - Rarely used

Bitmaps – data (TPC-H)

Settings:

```
lineitem ( L_ORDERKEY, L_PARTKEY , L_SUPPKEY, L_LINENUMBER,  
L_QUANTITY, L_EXTENDEDPRICE ,  
L_DISCOUNT, L_TAX , L_RETURNFLAG, L_LINESTATUS ,  
L_SHIPDATE, L_COMMITDATE,  
L_RECEIPTDATE, L_SHIPINSTRUCT ,  
L_SHIPMODE , L_COMMENT );
```

```
create bitmap index b_lin_2 on lineitem(l_returnflag);
```

```
create bitmap index b_lin_3 on lineitem(l_linestatus);
```

```
create bitmap index b_lin_4 on lineitem(l_linenum);
```

- 100000 rows ; cold buffer
- Dual Pentium II (450MHz, 512KB), 512 MB RAM, 3x18GB drives (10000RPM), Windows 2000.

Bitmaps -- queries

Queries:

□ 1 attribute

```
select count(*) from lineitem where l_returnflag = 'N';
```

□ 2 attributes

```
select count(*) from lineitem where l_returnflag = 'N' and  
l_linenumber > 3;
```

□ 3 attributes

```
select count(*) from lineitem where l_returnflag =  
'N' and l_linenumber > 3 and l_linestatus = 'F';
```

Bitmaps

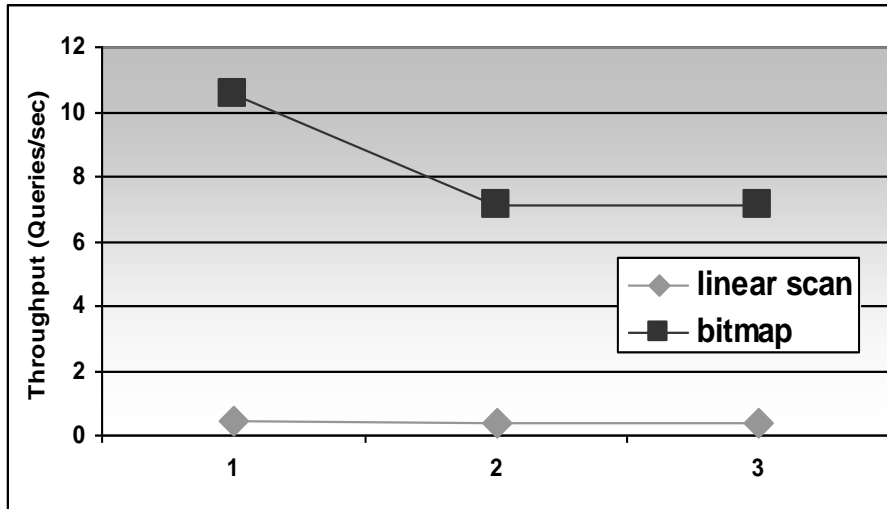

- Order of magnitude improvement compared to table scan.
- Bitmaps are best suited for multiple conditions on several attributes, each having a low selectivity.

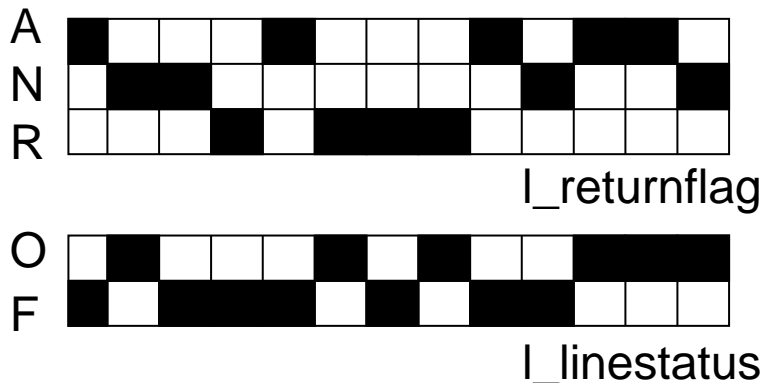

Multi-key / Composite index

- Index on multiple attributes
- Motivation:
SELECT name, salary FROM emp
WHERE dept='Toys' AND salary < 10000
- Alternatives:
 - a) Index on one attribute + filtering
 - b) Combine two indexes + intersection of candidate record pointers
 - c) Index in index
 - d) Concatenation of key values into one

Index on one attribute

- SELECT name, salary FROM emp
WHERE dept='Toys' AND salary < 10000
- Index on *dept*
 - Filter found records using *salary < 10000*

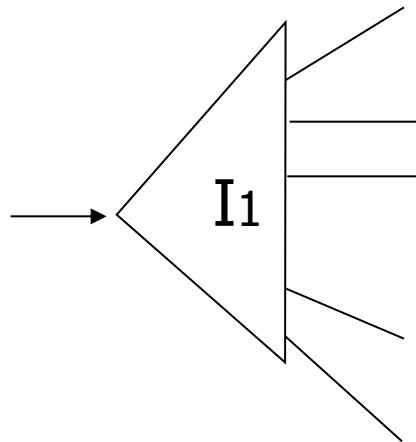

Combining Indexes

- Index on *dept*
- Index on *salary*
- Each index returns a list of candidate records
 - Intersection of lists → query result

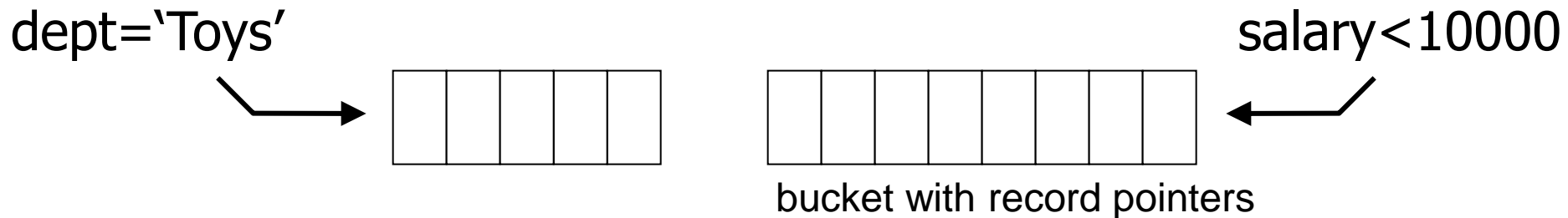

Index in index

- Index on the first attribute

- In leaves, pointers to embedded indexes on 2nd attribute

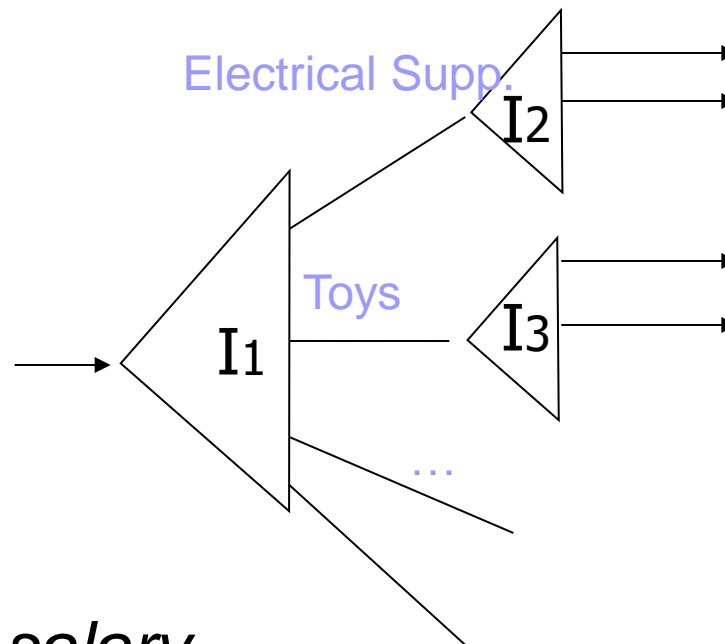

- I_1 on *dept*

- I_x , $x=2..k$ on *salary*

- I_2 contains only records having the same dept. value (Electrical Supp.)

Index in index: Example

- `SELECT name, salary FROM emp WHERE dept='Toys' AND salary < 10000`

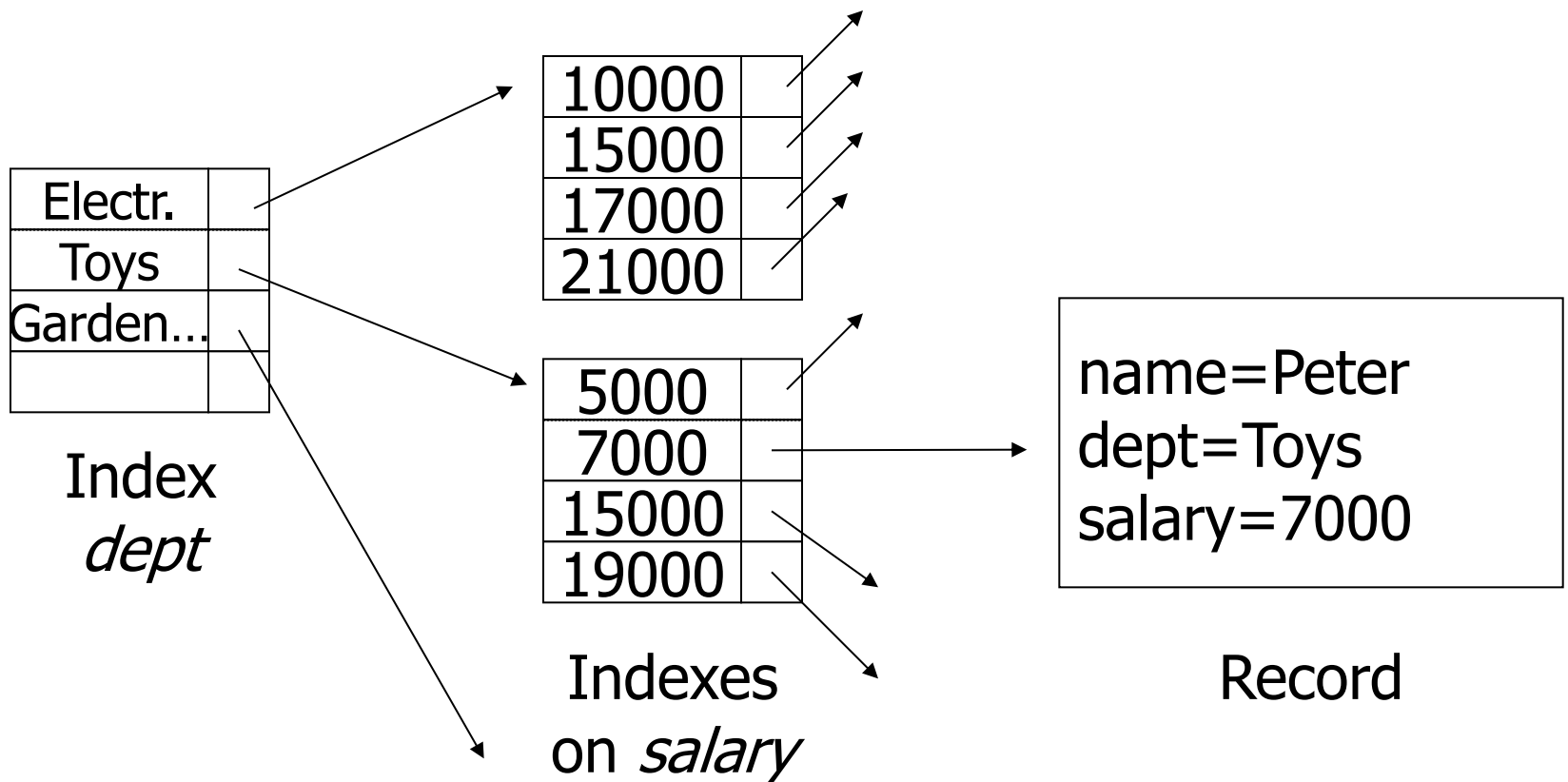

Index in index

- What queries can use this solution?
 - SELECT name, salary FROM emp WHERE
 - a) dept = 'Toys' AND salary \geq 10000
 - b) dept = 'Toys'
 - c) salary = 10000

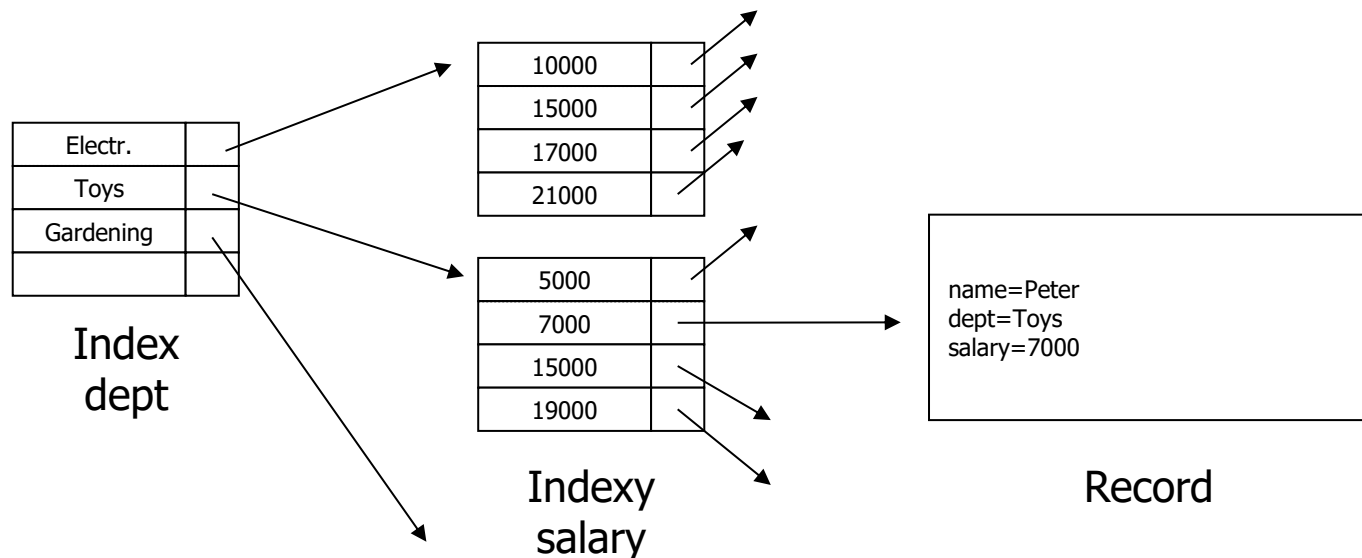

Concatenation of key values

- Analogous to an index on one attribute
 - Key values are merged
 - String concatenation, number multiplication, ...
- Indexing
 - rarely used unless (string) keys are compressed
- Hashing
 - Partitioned hash function

Partitioned hash function

■ Idea:

- Two keys
- Two hash functions
- One address

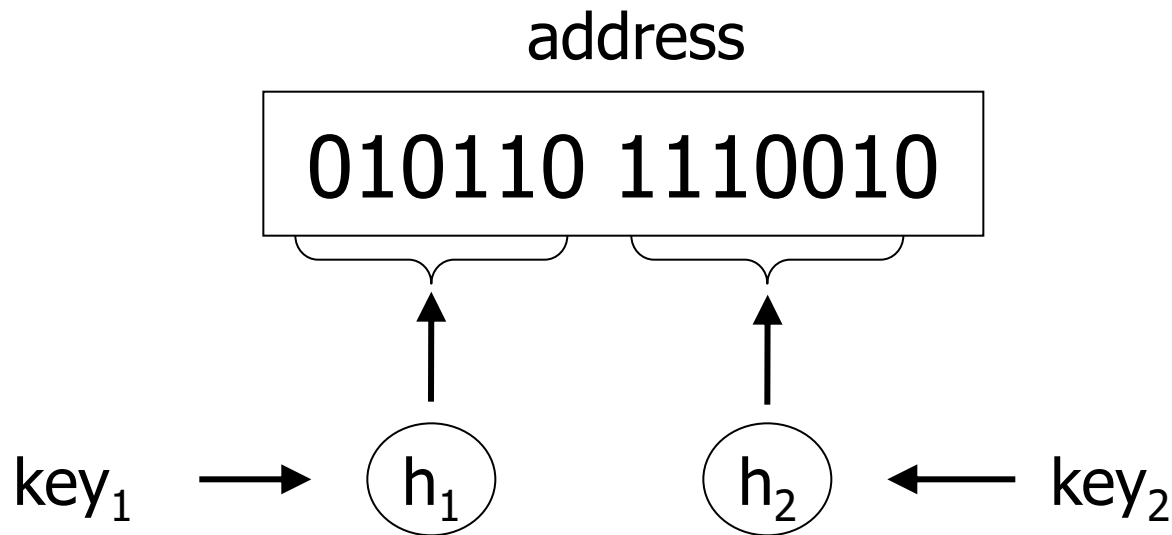

Partitioned hash function: Example

■ Dept

$h_1(\text{Electr.})=0$

$h_1(\text{Toys}) = 1$

$h_1(\text{Gardening}) = 1$

■ Salary

$h_2(10000) = 01$

$h_2(20000) = 11$

$h_2(30000) = 10$

$h_2(40000) = 00$

■ Records to insert

<Peter,Electr.,10000>

<Jan,Toys,10000>

<Alice,Gardening,30000>

000	
001	<Peter,Electr.,10000>
010	
011	
100	
101	<Jan,Toys,10000>
110	<Alice,Gardening,30000>
111	

Partitioned hash function: Example

■ Dept

$h_1(\text{Electr.})=0$

$h_1(\text{Toys}) = 1$

$h_1(\text{Gardening}) = 1$

■ Salary

$h_2(10000) = 01$

$h_2(20000) = 11$

$h_2(30000) = 10$

$h_2(40000) = 00$

■ Find

□ employess in Toys dept. with salary of 40000.

000	<Pavel,...> <Lukáš,...>
001	<Peter,...>
010	<Marie,...>
011	
100	<Anna,...>
101	<Jan,...>
110	<Alice,...>
111	<Veronika,...>

Partitioned hash function: Example

■ Dept

$h_1(\text{Electr.})=0$

$h_1(\text{Toys}) =1$

$h_1(\text{Gardening}) =1$

■ Salary

$h_2(10000) =01$

$h_2(20000) =11$

$h_2(30000) =10$

$h_2(40000) =00$

000	<Pavel,...>	<Lukáš,...>
001	<Peter,...>	
010	<Marie,...>	
011		
100	<Anna,...>	
101	<Jan,...>	
110	<Alice,...>	
111	<Veronika,...>	

■ Find

employees with salary 30000

Partitioned hash function: Example

■ Dept

$h_1(\text{Electr.})=0$

$h_1(\text{Toys}) = 1$

$h_1(\text{Gardening}) = 1$

■ Salary

$h_2(10000) = 01$

$h_2(20000) = 11$

$h_2(30000) = 10$

$h_2(40000) = 00$

■ Find

employes in Toys dept.

000	<Pavel,...>	<Lukáš,...>
001	<Peter,...>	
010	<Marie,...>	
011		
100	<Anna,...>	
101	<Jan,...>	
110	<Alice,...>	
111	<Veronika,...>	

Another Multi-key Index

- Grid index

- Idea:

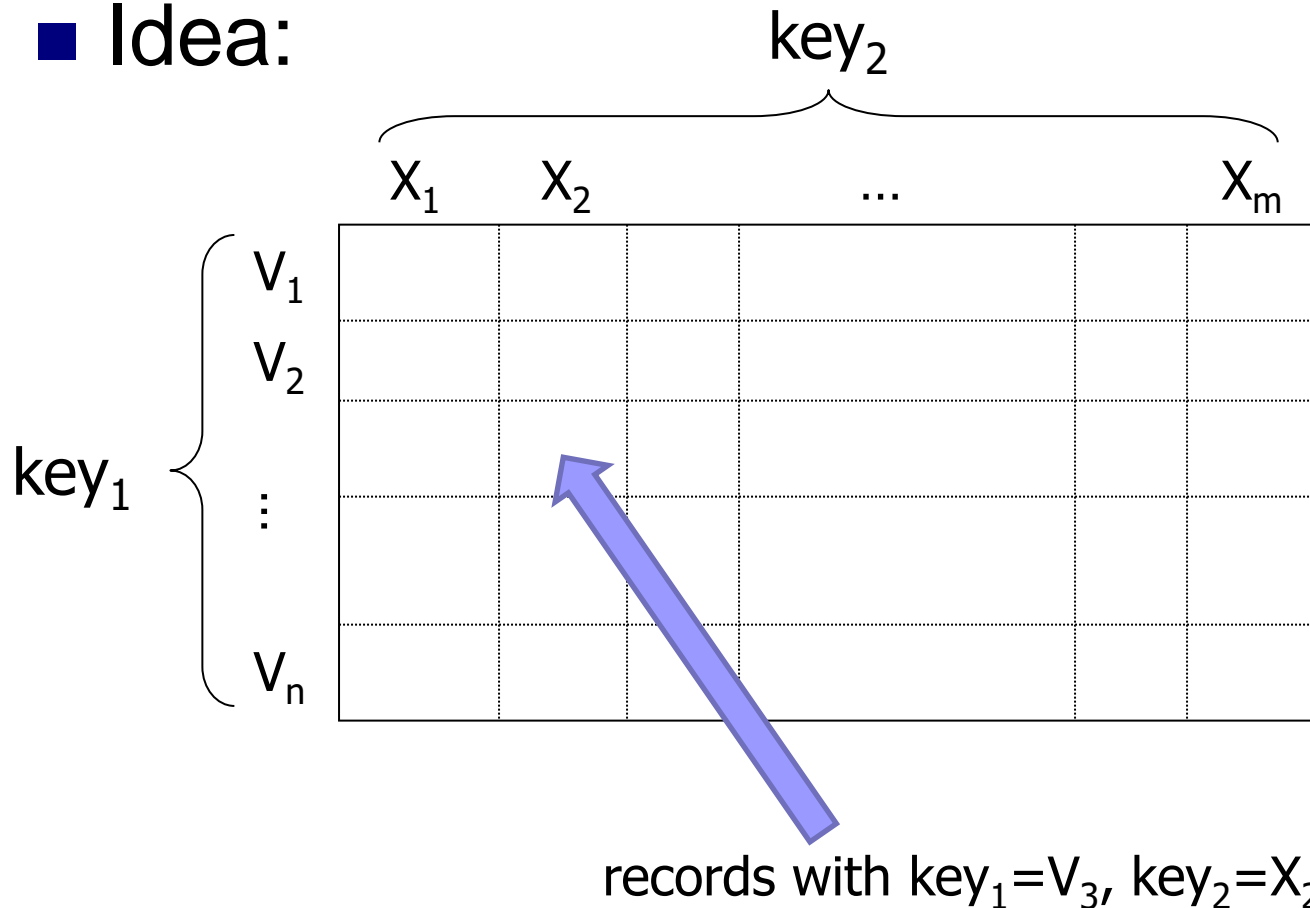

Grid Index: Properties

- Efficient for exact match queries

- $\text{key}_1 = V_i$ and $\text{key}_2 = X_j$

- $\text{key}_1 = V_i$

- $\text{key}_2 = X_j$

- Range queries

- $\text{key}_1 \geq V_3$ and $\text{key}_2 < X_3$

- Rectangular area

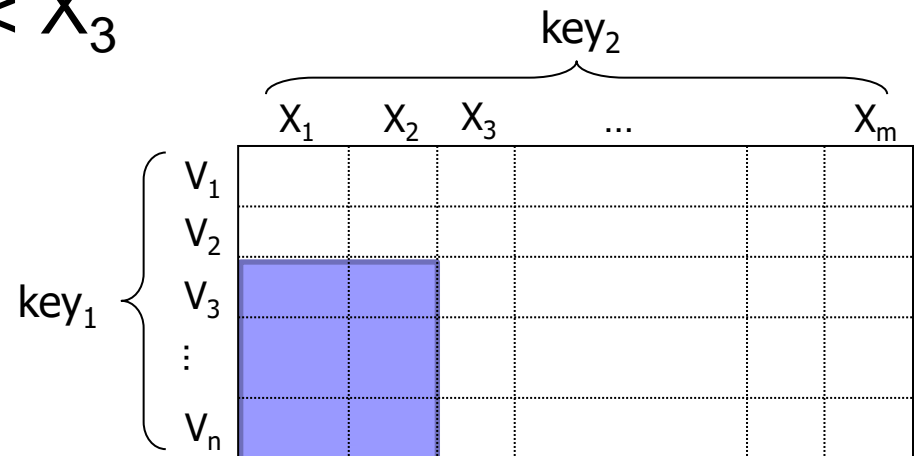

Grid Index: Implementation

- How to store grid on disk?

- one-dimensional array

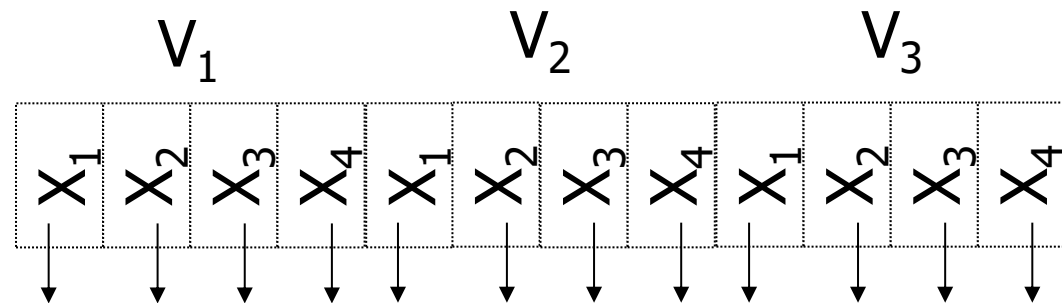

- Tradeoff: grid dimensions vs. cell capacity

- Disadvantage

- Grid dimensions must be fixed

- They are needed to calculate position of cell $\langle V_x, X_y \rangle$.

- Limited cell capacity

Grid Index: Implementation

- Use buckets, i.e., indirection
 - Grid cell points to a bucket

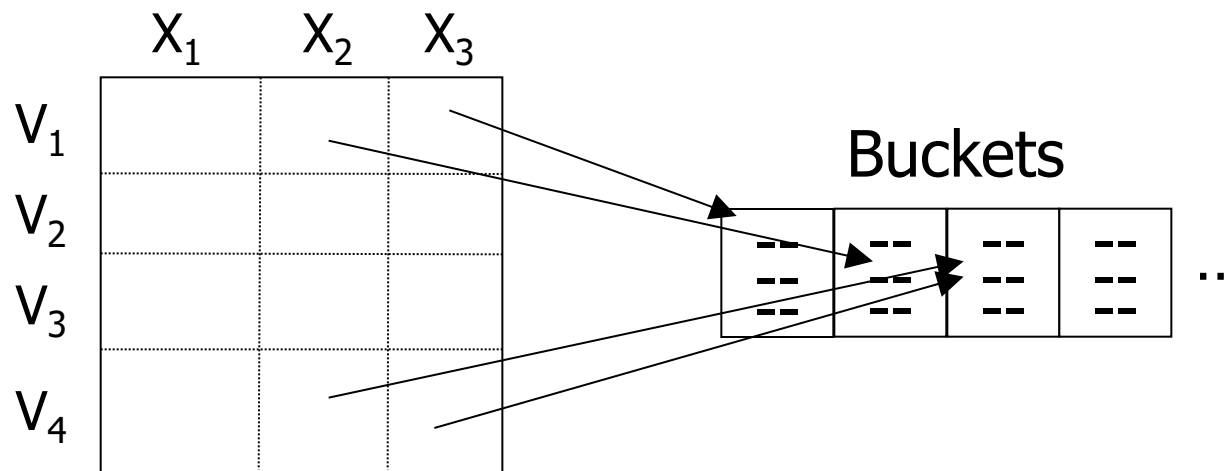

- Grid is fixed-sized
 - Overhead with indirection
 - Allows allocating buckets linearly.

Grid Index: Defining Grid

- Analysis of data and query types
 - Find out dimensions of the grid
 - Value on an axis can be an interval → binning
 - E.g., numeric domains

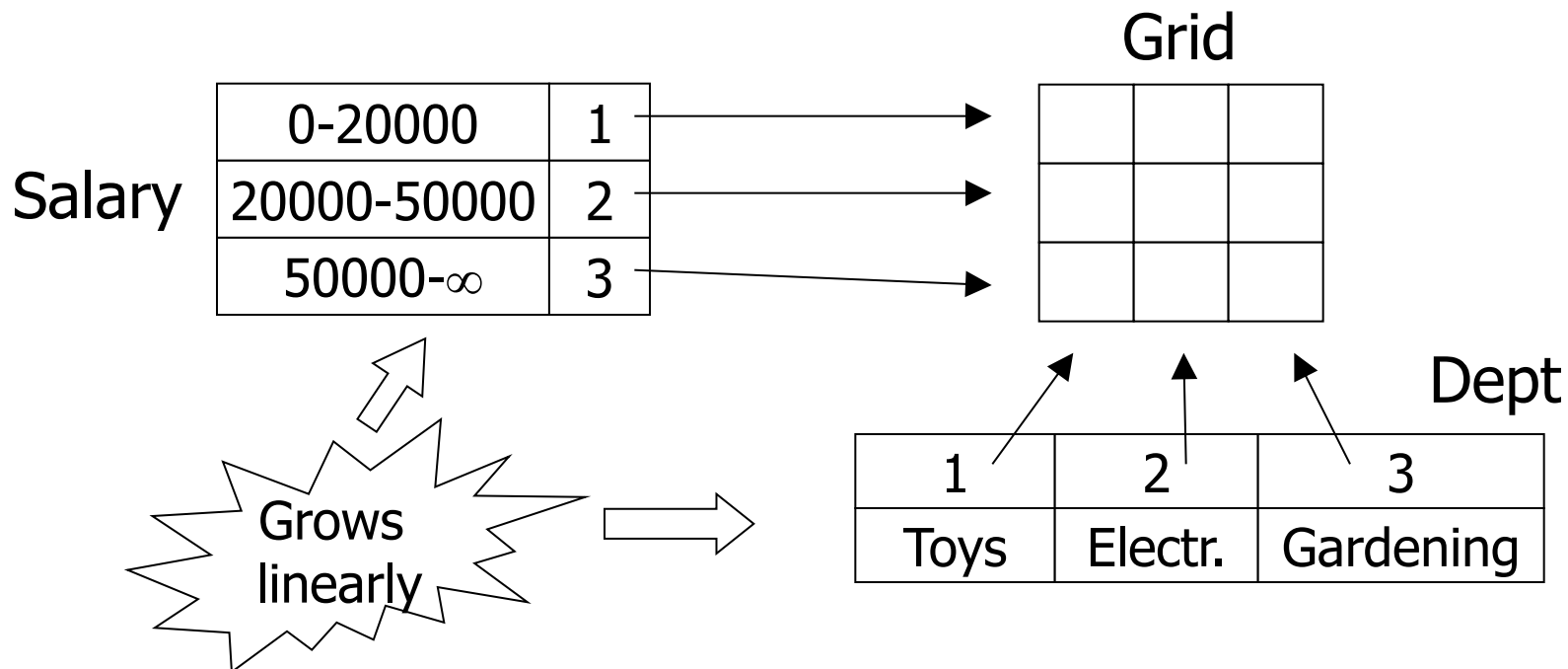

Grid Index: Summary

■ Advantages

- Good for multikey indexing

■ Disadvantages

- Grid size is fixed; may waste space
 - Alternative is a hierarchical grid
- Choice of grid intervals (quantization)
→ uniform data distribution

Index Design Guidelines

- Good selectivity (i.e., low value of selectivity)
 - Fraction of matching rows is small
- “Short” attribute values
 - Increase tree fan-out
- On “join” attributes
- Prefer more single-attribute indexes
 - for one multi-attribute one
- Few indexes for highly-updated tables
- No indexes for tiny tables

Lecture's Takeaways

- Techniques of hashing
- Recall handling duplicate keys
 - i.e., multiple records with the same key value.
- Alternative indexes
 - Bitmap index
 - do not mix up with bitmap scan in Pg's explain plan
 - Grid index
- Further terms (follows...)

Further Terminology

- Clustered index
 - = index-sequential file / B⁺-file
 - Records are stored in leaf nodes and cannot be accessed in any other way (than by this index)
- Non-clustered index
 - = secondary index / B⁺-tree
- Covering index
 - Query can be fully answered using the index only
 - i.e., records are not accessed.
 - MS SQL Server: *Index with included columns*
 - Not a multi-attribute index, but leaf node values are enriched with values of the included cols.
- Indexed view
 - materialized view with clustered index
- Multidim. data and indexes (R-trees, Quad Trees, kd-trees)