

Chapter 6

The Cockpit of Europe

In the Middle

Bohemia, the economic heart and core of the new nation of Czechoslovakia, had also been the industrial core of the Austro-Hungarian Empire. Since it occupied a key location in Central Europe and had had a turbulent history, Prussian Chancellor Otto von Bismarck called it the 'Cockpit of Europe', adding that 'the master of Bohemia is the master of Europe'. During the Austro-Prussian War of 1866, the Prussian Army marched into the Bohemian fortress of Austria winning the Battle of Königgrätz (today Hradec Králové) and establishing German dominance. However, even though the destructive Thirty Years War began in Bohemia in 1618, after 1866, this corner of the Austrian Empire remained untouched by war but failed to make Austria the 'Master of Europe'.

At the end of the First World War, Austria was stripped of Bohemia, Moravia, Slovakia, and Ruthenia, while Germany lost the Sudetenland, which were integrated into the new nation of Czechoslovakia. The post-war population of this new nation of over 13 million consisted of about 42 per cent Czechs (Bohemians and Moravians), 23 per cent Slovaks, 23 per cent Germans, 5 per cent Hungarians, 3 per cent Ruthenians, and the remainder other groups. This made the nation about 70 per cent Slavic and about 24 per cent Germanic, which created a potential boiling pot and made Belgium's ethnic divisions appear insignificant.

Despite ethnic differences, the new nation held together and grew into a major economic and military power in Central Europe, largely because of the

industrial resources already established in Bohemia and Moravia. The Sudeten Mountains formed a natural barrier along the frontier with Germany and Austria. However, territorial disputes with other neighbours cropped up. The most serious was with the Poles after in 1920 the League of Nations divided Teschen, giving the Czechs the district with the coal.

In 1920, Czechoslovakia formed the Little Entente with Rumania and Yugoslavia (formally ratified by all parties in 1921) to prevent a resurgence of Hapsburg power in Austria and to contain Hungary.¹ In 1921, the French signed a military alliance with Poland unsettling the Czechs who signed their own agreement with France in 1924 without military commitment. The Kellogg-Briand Pact of 1928 attempted to outlaw war altogether. Czechoslovakia, its neighbours, and over fifty other nations signed the pact. It is difficult to judge how reassuring this agreement was for the Czechs, but mistrust of the Poles continued and the rise of Hitler produced new concerns in 1934.² The German-Polish Non-Aggression Pact of January 1934 further alarmed the Czechs. The signing of the Rome Protocol in March 1934 aligned Italy, Austria, and Hungary and fanned the Czechs' fears. French influence began to wane in Central Europe, until the Soviet Union and France signed a pact of mutual assistance with the Czechs in May 1935. Believing they would have allies to bolster their faltering Little Entente, the Czechs supported the sanctions of the League of Nations against Italy during Mussolini's Abyssinian adventure.³ The Czechs became alarmed when Hitler ordered the reoccupation of the Rhineland in March 1936 and when Italy joined Germany to form the Axis powers. However, the Czechs, determined not to be caught flat-footed, took measures for their own active defence beginning in the early 1930s. Their army had dropped to just under 100,000 men in 1934, but Edouard Beneš (1884–1948) remedied the situation.⁴ Military service soon increased to two years and the military expanded.

The country had the Skoda Works, an armaments industry considered only second to Krupp in Germany.⁵ Engineer Emile Skoda's company, located at Pilsen, had been the arsenal of Austria-Hungary in the nineteenth century. The expanded company produced a variety of weapons, automobiles, and equipment. During the previous war, the Skoda factories had produced 305mm and even

420mm artillery pieces. Thus, the Czechs had the technology and ability to increase armament production in the early 1930s and become a major arms supplier. By 1934, the first Czech tanks rolled out of the Skoda factories. The Czech light and medium tanks were superior to the German Panzer I, which formed most of the Nazi armoured force in the 1930s.

The Czech government was not interested in an offensive war, but rather the defence of its nation. The 1930s era of the Great Depression in Europe coincided with a period of massive fortification building. The French began the decade with the construction of the Maginot Line to seal their German frontier. The Germans, at the same time, began work on the East Wall and on their West Wall in 1936. The Italians created their Vallo Alpino across their mountainous borders. The Belgians and Dutch prepared defensive lines. The members of the Little Entente joined the Czechs in this age of fortification building by creating the Carol Lines in Rumania and the Rupnik Line facing Italy in Yugoslavia. In 1934, a Czech military mission travelled to France for an inspection of the Maginot Line. The French dispatched General Belhague, one of the designers of the Maginot Line, and other French advisers to Czechoslovakia.

The Czechs had inherited no modern fortifications. The only fortifications they had were at Komarno, Theresienstadt, Josefstadt, and Olmütz. They rebuilt Komarno in the 1920s, but the others were obsolete. The Czech border with Germany spanned about 1,550km, the one with Austria, 550km, and the one with Hungary, 600km. Due to poor relations with Poland, the Czechs had to consider defending that 820km border. The main invasion routes included the Oppeln (Polish Opole)-Moravian Gate, the Glatz (Polish Klodzko) Basin-Brno, the Glatz (Klodzko) Basin-Prague, and Waldenberg (Walbrzych)-Prague, all located in Silesia south of Breslau. Thus, priority went to the defence of the sectors between Trutnov-Nachod and Opava-Ostrava since a successful German invasion force through that area could split the nation in two. The natural obstacle created by the Sudetenland surrounding Bohemia became the first line of defence against Germany. Successive lines were added as well. General Ludvík Krejčí (1890–1972),⁶ Chief of Staff from 1933 to 1938, told historical researcher Dr Peter Gryner in 1968 that the army intended to use these

successive lines and fall back into Moravia if need be. The army, he stated, was to make its last stand by withdrawing into the mountainous terrain of Slovakia. Thus, the Czechs' philosophy was similar to the Swiss because they considered abandoning the main population centres to hold a mountain fortress area as a last resort. The main difference was that the Czechs had the hope of receiving help from Rumania, one of their Little Entente allies, or even from the Soviets who had signed a mutual support agreement with France in 1935 undertaking to assist Czechoslovakia.⁷ According to General Julien Filippo, a French military advisor, the Czechs enlarged the airfields at Košice in eastern Slovakia and Uzhorod in Ruthenia to receive heavy Soviet transport aircraft and to serve as main bases for the Czech air force.

In 1935, General Krejčí first proposed a ten-year plan for the nation's defences. His superior, General Jan Syrový (1888–1970), pushed for the creation of a Czech Maginot Line.⁸ Work was well underway when the Austrian Anschluss in March 1938 left the Czech heartland almost surrounded by Nazi Germany. A bush-league Führer named Konrad Henlein had formed his own pro-Nazi political group in the 1930s with ethnic Germans in the Sudetenland. In 1938, under the influence of Nazi Germany, his group increased agitation activities to give Hitler an excuse for a move against Czechoslovakia. The Czech government could not afford to abandon its first line of defence to Hitler, so in May and again in the early autumn of 1938, it mobilized its well-armed military. The only serious weakness was that the nation's major fortifications had not yet been completed.

Defensive Lines

The first line of defence ran through the Sudetenland, which comprised several mountain ranges east of the Elbe River from around Dresden to Ostrava. These ranges include the Lužické Hory (Lusatian Mountains, an extension of the Ore Mountains), Jizerkské Hory, and Krkonoše (Giant Mountains) in the Western Sudeten; Orlické Hory (Eagle Mountains) in the Central Sudeten; and the Hory Jeseníky (Ash Mountains) in the east where the highest elevation was Praděd at 1,491m (4,892ft). The very rugged terrain on either side of the Elbe River,

known as Bohemian Switzerland, is formed by the Lusatian Mountains east of the river, and the Ore Mountains on the west. The highest mountain rises to 726m. It includes the Elbe (Czech Labe) River Canyon that cuts into the sandstone mountains. This region stretches from Děčín to Kyjov.

The Ore Mountains (Czech Krušné Hory, German Riesengebirge) create a natural border between western Bohemia and Germany west of the Elbe. The mountains of the Český Les and the Šumava Mountains form much of the border with Austria. The Šumava reach elevations of above 1,500m. The Eisentein Pass is one of the few natural access points through this barrier.⁹ The Carpathian ranges dominate much of Slovakia, although large parts of its southern frontier with Hungary are relatively open.

The heaviest Czech fortifications were built on either side of the Orlické Hory, extending from the vicinity of Trutnov-Nachod to Králiky-Ostrava. Small sections of the border with Austria south of Brno, Bratislava, and a small part of the Hungarian border received heavy fortifications, but no forts. Lighter defence lines covered the border across the northern part of Bohemia from the Ore Mountains to the vicinity of Trutnov-Nachod and most of the Austrian border. In the west, two lines of light fortifications ran from the southern border to the northern border, one covering Pilsen and the other covering Prague. The long vulnerable border with Hungary also had light border defences. The Carpathians and the defences near Ostrava covered the Polish border. Only the short 200km border with Rumania, Czechoslovakia's only ally, was open.

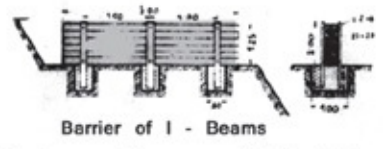
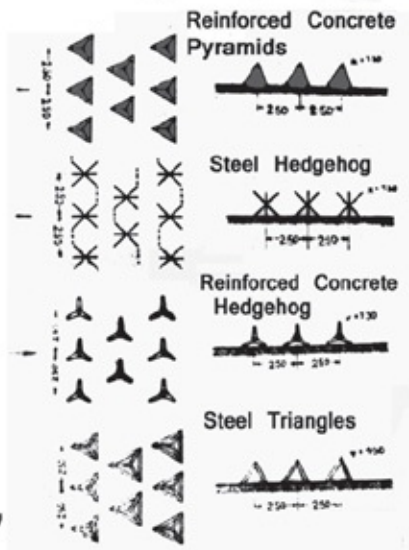
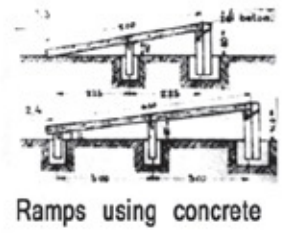
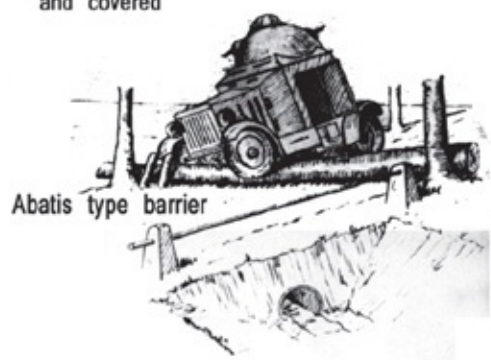
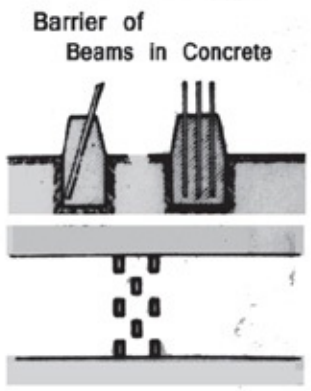
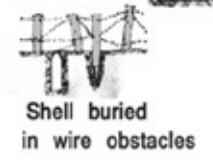
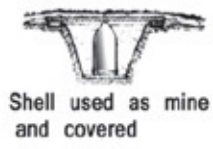
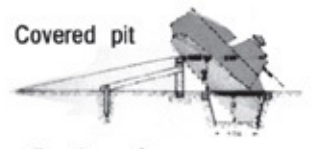
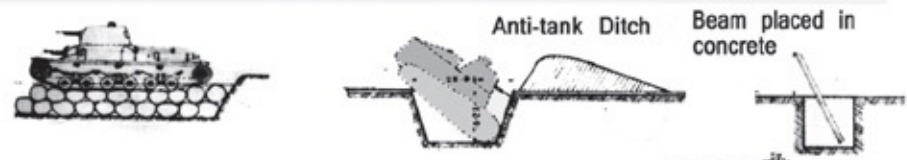
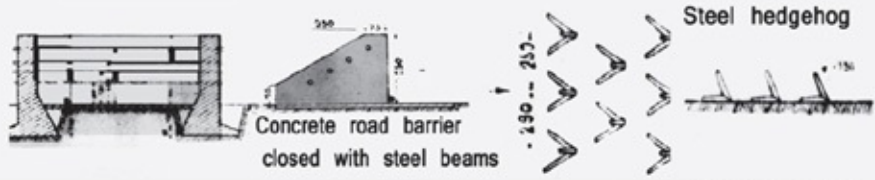

Various Types of Anti-Tank Obstacles developed by 1937

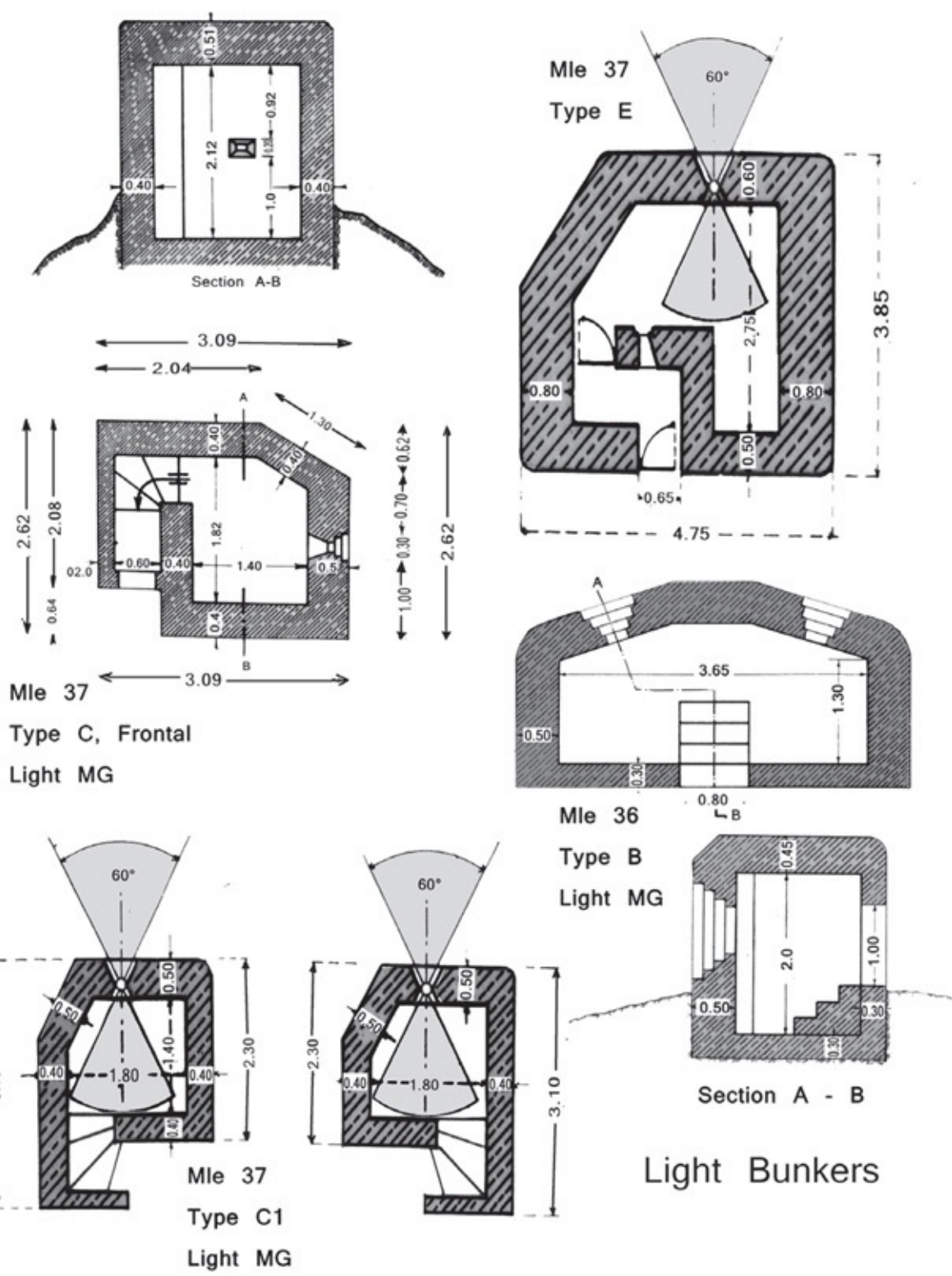

Examples of Mle 1936 and 1937 light bunkers for frontal fire.

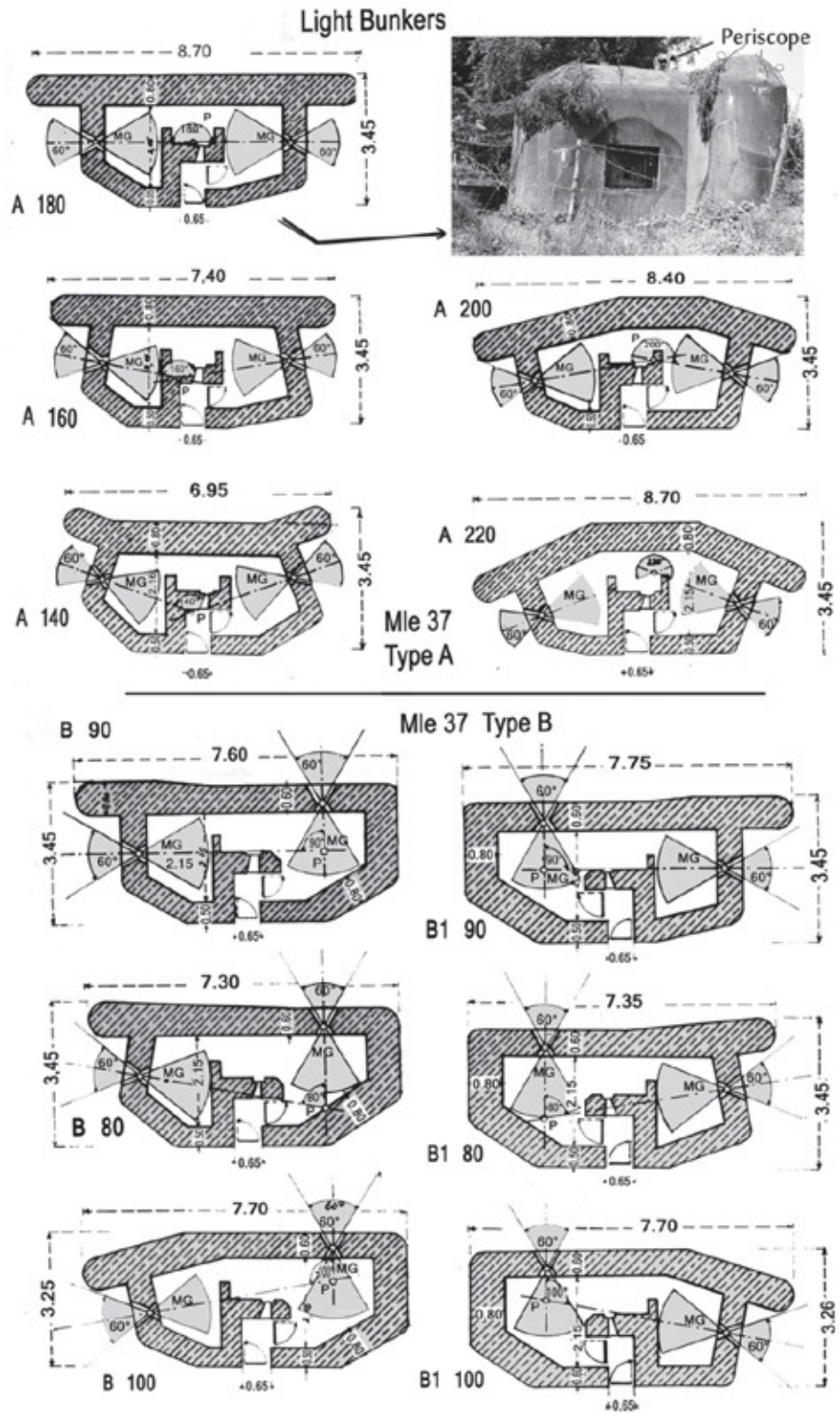

Examples of several types of Mle 1937 light bunkers.

The Czech Army engineers drew up the plans and directed the building of all fortifications. Officers oversaw the work of private construction companies and collaborated with several companies for the production of the required weapons and equipment. The government did not use foreign construction companies and avoided using non-Czech equipment and other components. Industrial Czechoslovakia had the ability to meet most of their military's needs. They even arranged to sell Czech-manufactured armoured clothes to their ally, Yugoslavia.¹⁰ The Ředitelství Opevnovacích Prací (ROP) – Directorate of Fortification Work – was set up to handle the administration of the fortification construction. General Charles Husárek (1893–1972) headed the ROP from its inception in March 1935 until the autumn of 1938 and set up a programme for four stages of construction. Not all historians agree on the years for each phase, but it appears that he intended the first phase to last from 1936 to 1941. The objective was to cover the frontier with Germany and exposed areas in the south with light defences and heavy fortifications in the most vulnerable sectors of the northern front. During the next stage, the Czechs concentrated on the exposed southern front of Slovakia and the creation of heavy fortifications in the lines of western Bohemia covering Prague and Pilsen. The following phases saw the completion of light defences in threatened areas on the frontier. In 1946, a second position in the north, further behind the main line, was to be added and additional positions were to be built in southern Moravia. During a final stage, which was to end in 1951, defences were to be built along the Polish border. The general's 15-year programme called for the creation of over 15,000 bunkers and heavy fortifications to encircle the nation.

The Czech Army built some bunkers within a year of Hitler seizing power in Germany. The first official design was the light Model 36. Light or heavy machine guns were placed on simple mountings such as wooden tables.¹¹ The crews ranged from two to seven men, depending on the design of the bunker, which had no poison-gas protection since they had no ventilators or airtight doors. The bunkers came in types A to F, but few of the last three types were ever built.¹² The A and B had two embrasures, C, the largest, had three and E only one. However, little information is available on types E, D, and F. The

embrasures were for frontal fire. Although they were concealed by the terrain and had minimal exposure, these bunkers were of little military value because they were located near the border in the Sudetenland where the ethnic Germans knew their locations. These Model 1936 bunkers offered little protection to the crews because the front walls were no thicker than 0.5m or 0.6m and the roof, 0.4m and 0.55m. At best, they could withstand a 75mm round if it did not hit the embrasure. In 1938, a German agent reported that during live-fire exercises the crew of one of these bunkers fainted from the gases of the expended rounds because these bunkers had no ventilation. The Czechs built over 860 of the Model 1936, before they switched to the new light bunker Model 1937 type, which was more substantial, to form continuous lines of defences. There were five types of Model 37 bunkers.

Model 37 Bunkers

<i>Type</i>	<i>Embrasures</i>	<i>Crew</i>	<i>Notes</i>
A	2 flanking embrasures	7	85 per cent of the Mle 37s built
B	1 frontal and 1 flanking embrasure	7	For closing valleys and defiles
C	1 frontal embrasure	3	To close gaps in line
D	Flanking embrasure	4	Built in pairs, 8 per cent of the Mle 37s built
E	1 frontal embrasure	4	

These casemates had ventilators and gas protection and most included a periscope. Type A had wing walls to protect its two flanking embrasures from frontal fires. The entrance in the rear formed an 'L' shape protected by an internal small arms embrasure. Most historians estimate that Type A accounted for about 85 per cent of all Model 37s built. Type B was similar to the Type A, but had one wing wall because it had one flanking embrasure and one frontal embrasure. Type C, the simplest and smallest model, was intended for frontal fire. Type D was about half the size of a Type A and had only one flanking embrasure. It was often built in pairs that covered each other. Type E was a larger version of Type C but had a protected entrance that Type C did not have. Most of the Model 37s had 0.8m thick front walls and 0.5m thick ceilings and rear walls. The reinforced versions had 1.2m front walls, 1.0m ceilings, and

0.8m rear walls.¹³ Over 9,000 bunkers of this type were built.

Neither the Model 1936 nor the Model 1937 bunkers formed a strong barrier except in rugged terrain. Light bunkers covered much of the Czech border with Germany and Austria. They included wire and antitank obstacles that were worthless if they were not covered by friendly fire.

The Czechs intended to build a line of large structures they called 'forts' in the heavily fortified lines between Trutnov and Ostrava, along the Austrian border south of Brno, and along the Hungarian border. These 'forts' were similar to the French CORF casemates¹⁴ of the Maginot Line, which filled the gaps between the Maginot forts. For this reason, we shall refer to them as casemates. The Czechs also identified them as independent infantry blockhouses. These casemates normally consisted of two levels, except where the water table did not permit, and supplied flanking fire with infantry weapons. Each was equipped to operate independently for up to a month. French influence through military advisors appears to have been heavy, especially since the Czechs were in a hurry to protect their borders and had little time to experiment while the peril from the Nazis grew. The casemates included an engine room, ventilators and filters, crew quarters, a water reservoir, and a communications room. The weapons embrasures on each flank were protected by a diamond fossé in front of them. The entrance had an air lock for gas protection. These casemates usually included a couple of cloches for observation and for infantry weapons to the front. In some types, only one firing chamber covered one flank. Like the French CORF casemates, these structures were infantry positions armed with machine guns and antitank guns. A special type of casemate mounted a pair of 90mm mortars.¹⁵

The strength of these casemates varied. In most cases, the roofs were 2.5m thick or more and the frontal walls were 2.75m thick. In addition, they were covered with about 4.0m of rock from the backfill. The side and rear walls were 1.5m thick. The strength of many of these casemates were rated II or III, but some were as weak as 2 (see the table on p. 183 on Reinforced Concrete Strengths).

One interesting heavy fortification the Czechs drew up plans for was a large

three-level artillery casemate. According to Martin Ráboň and Tomáš Svoboda, authors of *Československá Zed*,¹⁶ the advantage of this special independent artillery casemate was twofold: it could be used in terrain with a high water table that prevented the construction of subterranean forts; and most importantly, it was more economical than a fort. The facade looked much like a fort artillery casemate with three 100mm howitzer positions protected by a fossé. One of the main differences was that the embrasures allowed the guns a 60° instead of a 45° degree field of fire. On the upper level, to the rear of the guns, and on the flank, there was an armoured door and an entrance large enough for a truck. An adjacent troop entrance included a decontamination area. A machine-gun position covered the entrance, and on the opposite side of the entrance, there was a firing chamber for a combination antitank gun/machine gun. Beyond the entrances, there were ammunition magazines, a lift, and a stairway. The middle level included more munitions magazines, quarters for the garrison, and latrines. The lowest level housed additional quarters – including the commander's, the engine room, fuel storage, comms room, and the ventilator and filter room. This type of casemate would have required a garrison of about 120 men. Ráboň and Svoboda have identified nine proposed locations for these positions. Most were to be built in South Moravia and a couple in the north to replace a fort. However, the Czechs never had time to build any.

Czech Independent Infantry Casemate

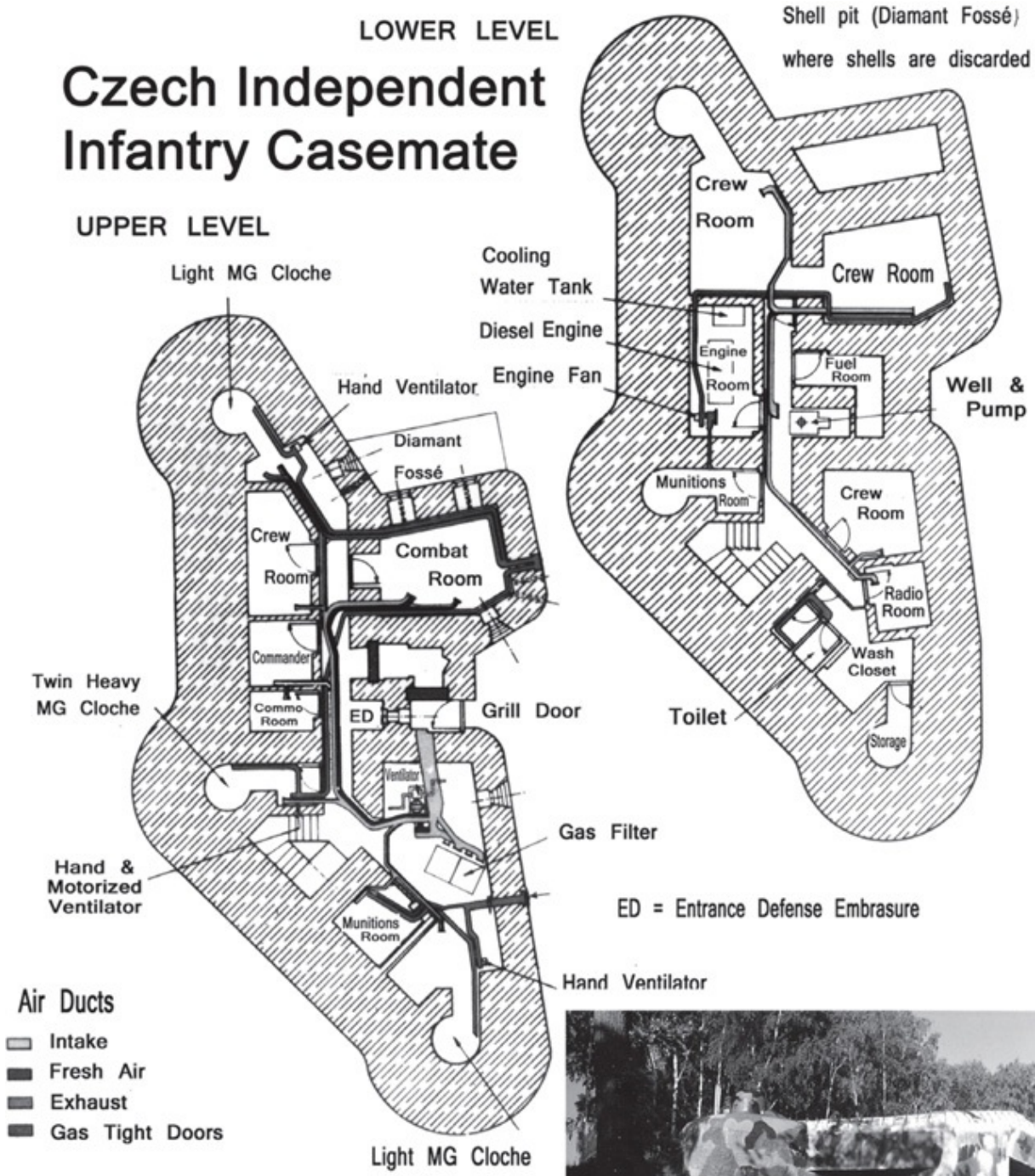

Casemate Brezinka near Nachod



The independent infantry casemate formed the backbone of most Czech defensive lines since the small number of forts were concentrated in a single area.

In April 1935, the Czechs created Fortified Sectors similar to those in France. The 15 sectors included ženijní skupinová velitelství (ZSV), Engineer Group HQ, set up between April 1935 and April 1938. Construction began within a month or a few months after the group became operational, but five of these groups were dissolved before construction could begin.

Fortified Sectors: Large Bunkers and Casemates Built

<i>Sector/Engineer Group HQ (ZSV) or Engineer Group (ZS)</i>	<i>Number of Sub-Sectors</i>	<i>Number of Large Structures Built (Planned) by Autumn 1938</i>	<i>Notes</i>
Moravska Ostrava ZSV II	5	41 (48)	Includes subsectors for 2 Tvrz.
Opava ZSV IV	6	26 (101)	Includes subsectors for 2 Tvrz.
Staré Mesto ZSV I	3	8 (84)	Includes subsector for 1 Tvrz.
Králiky ZSV III	7	56 (57)	Includes subsectors for 3 Tvrz.
Rokytnice ZSV X	4	39 (39)	Includes subsector for 1 Tvrz.
Náchod ZSV V	6	37 (100)	Includes subsectors for 2 Tvrz.
Trutnov ZSV VI	9	38 (122)	Includes subsectors for 3 Tvrz.
Liberec ZSV VII	6	0 (30)	West of subsector Trutnov
Moravia (South) ZSV XI	3	6 (68)	South of Brno
Bratislava ZS 21	–	8 (26)	Plus some modernized 1935 bunkers
Komano*	–	3 (5)	

* The only relatively modern fort the Czechs had in the 1920s.

Source: Martin Ráboň, *Přehled Tezkeho Opevnění* (self-published, Military Club, Brno, 1994).

ROP created a table of resistance strengths similar to the one the French used for their own fortifications. Roman numerals identify the concrete requirements for heavy fortifications and Arabic numerals for the lighter defences. Most casemates used strength II and a significant number had strength III. Combat blocks of the Tvrz. (forts) used IV.¹⁷

Reinforced Concrete Strengths: Czech Compared to French Maginot Line

<i>Czech Strength</i>	<i>Front Wall</i>	<i>Rear and Side Walls (French)</i>	<i>Roof</i>	<i>Resists Weapons of Czech (French)**</i>	<i>French Protection*</i>
I	1.75m	1.00m	1.50m	210mm (150mm)	1
II	2.25m	1.00m	2.00m	280mm (240mm)	2
III	2.75m	1.25m (1.00 to 1.30m)	2.50m	305mm (300mm)	3
IV	3.50m	1.50m rear 1.25 m side (1.30m)	3.50m	420mm (420mm)	4
1	1.20m	0.80m	1.00m	155mm	–
2	1.75m	0.80m	1.50m	180mm	–

* French Maginot artillery forts (Gross Ouvrages) mostly had Strength 4 for their combat blocks, while the smaller infantry forts (Petits Ouvrages) usually had 3. The French referred to it as ‘protection’ instead of ‘strength’.

**The difference in resistance between the Czech and French may be attributed to the type of concrete mixture. In the opinion of Dr Peter Gryner, the ‘Blue Concrete’ used by the Czechs gave greater resistance strength. Gryner also claims that the engineers used gravel between layers of concrete. According to a German intelligence report of 1938, cork was used for sound insulation.

The armour strength rated for turrets and cloches had a ROP code:

<i>ROP Code Number</i>	<i>Armour Thickness</i>	<i>Czech Strength</i>
1	15cm	1
2	15cm	2
M	20cm	I
S	20cm	II
V	30cm	III
W	30cm	IV

Most cloches mounted a light Mle 26 machine gun and a periscope in the roof for observation. Cloches (and cupolas) of this type came in all the listed categories of resistance, ranging from 15cm to 30cm. The smallest weighed 13 tons and the largest about 65 tons. The cupolas – the Czechs used the term ‘offensive cloche’ – for the heavy Mle 37 machine gun were similar, but only came in strengths of I to IV. They usually had one or two embrasures for a machine gun and two small observation ports. One type had a single embrasure

for a twin heavy machine gun with two observation ports similar to the French model. In artillery observation cloches, there was a periscope in the roof and optical equipment through the embrasures (up to four embrasures), but there were no weapons.

Machine Guns Mounted in Trz

MG Cloches

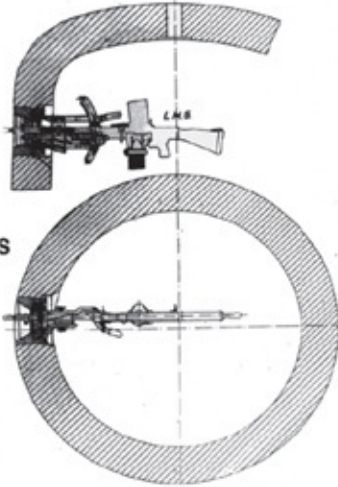

Light MG in Cloches

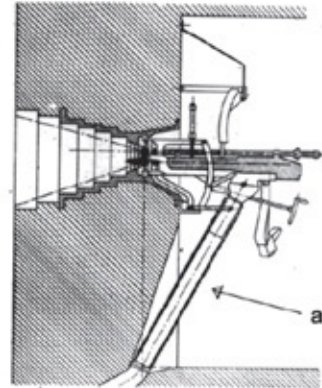

Twin Machine Gun in Casemate



Infantry Casemate with Cloche for a heavy machine gun

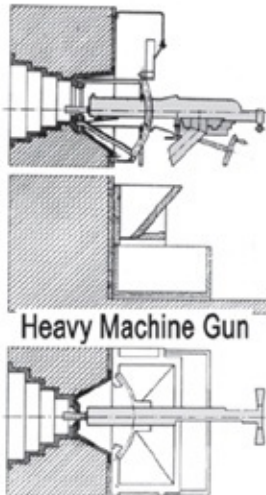

Heavy Machine Gun

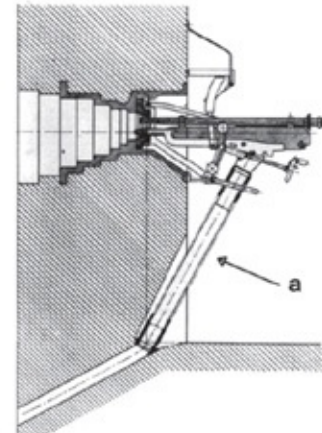
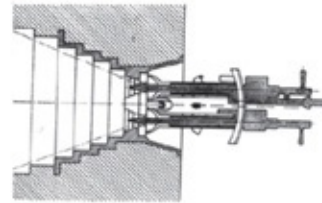

Heavy Machine Gun in Casemate



Cloche for Light Machine Gun before installation

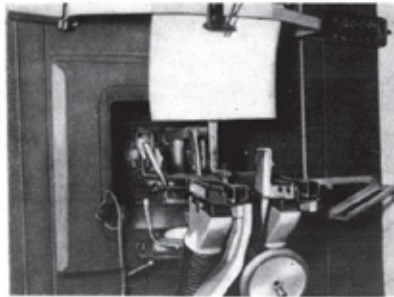

a = tubing carrying expended shells & gases into opening in wall leading into fossé. Similar method used in Maginot forts.

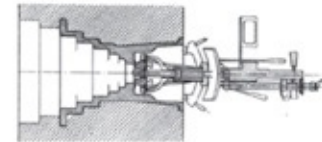

Photo of Heavy Machine Gun in casemate with overhead map and pointer

Examples of cloches and machine-gun positions.

Important features of the Czech defences were obstacles of various types. Barbed wire fences and entanglements encircled most fortifications and covered large sections of the border. German intelligence agents, V-Men, investigating the Czech defences tried to determine if some of the border wire was electrified. Electrification did not seem to be practical because it was not effective except in preventing illegal border crossings or securing storage areas and secret sites. In battle, a bombardment would quickly disable the electrical function with a few breaches in the wire. In some rough terrain unsuitable for tanks, the barbed wire ran through steel posts with concrete bases that the enemy could not easily remove.

Direction of Attack



Barrier of Concrete & Iron
Hedgehogs - Older Layout

Iron Posts for Barbed Wire
with concrete bases

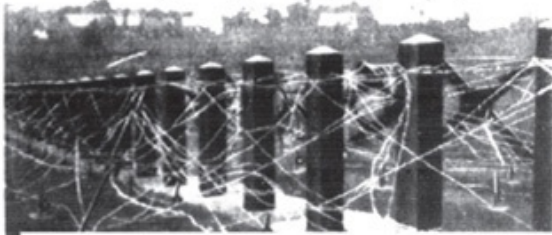
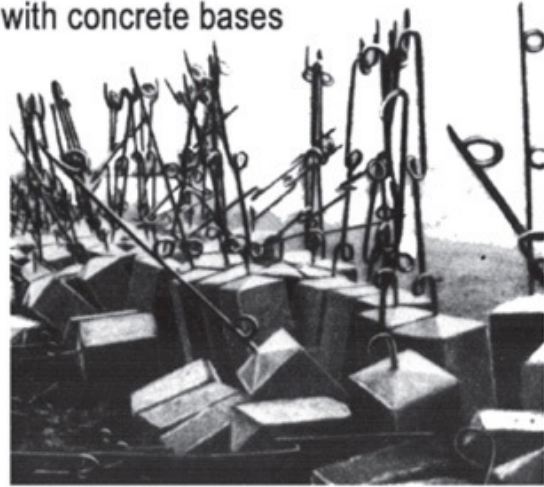

Barrier of Reinforced Concrete Posts

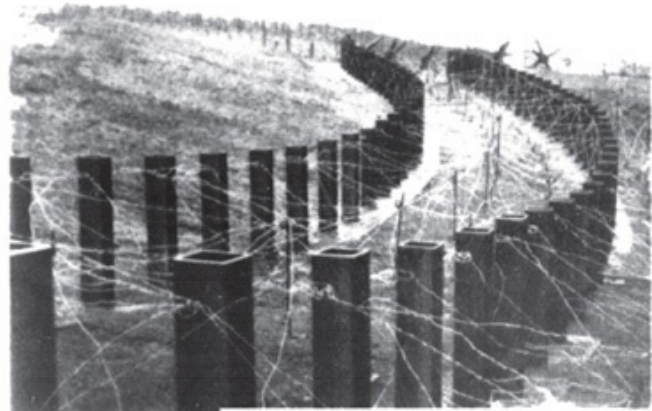

Tank and Infantry Barrier



Barrier of Ferro-concrete Hedgehogs

CZECH ANTI-TANK and INFANTRY OBSTACLES

Various types of Czech obstacles taken from German documents prepared after the occupation.

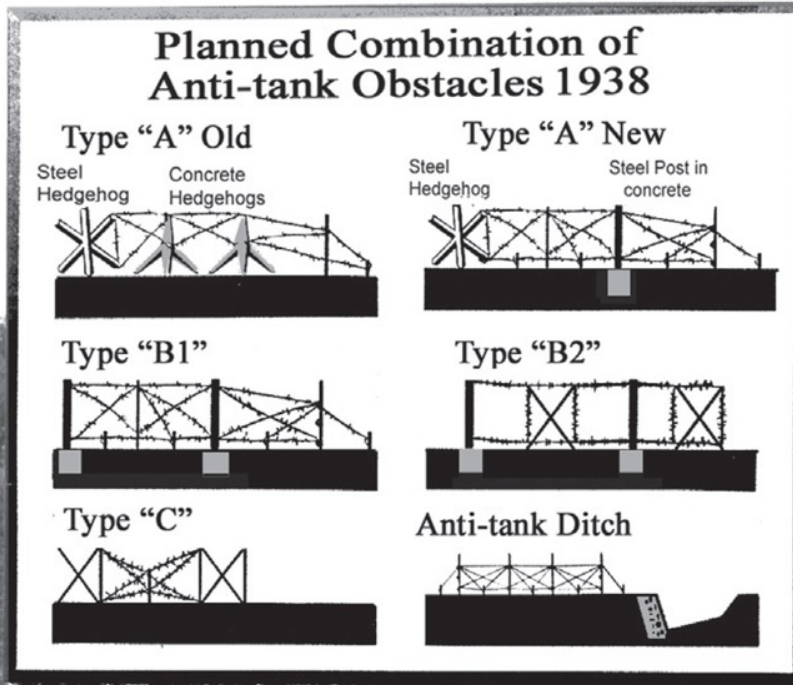

Sign at Dubrovnik showing types of AT obstacles.

The most important type of obstacles closed roads to vehicles and barred tanks from the countryside. By the fall of 1938, an almost continuous line of antitank obstacles was put in place in the sectors for heavy fortifications of the Beneš Line in the north. Some passes along the German border were outfitted with concrete walls to block traffic in time of war. This type of roadblock sometimes consisted of several sections of wall set up to form a chicane in front of another wall with a gap that could be sealed with other obstacles in time of war. The most famous of the obstacles was the hedgehog developed to stop tanks in 1936. The first type of hedgehog, a concrete version with three legs forming a base, had a ring on the arm that projected upward, which allowed troops to move the obstacle into position. The ring could also be used to attach barbed wire. It was supposed to be able to stop a tank, but it did not turn out to be as effective as hoped. These concrete hedgehogs were deployed in a continuous barrier of one to three rows to which steel ones were sometimes added. The steel hedgehogs usually consisted of three L-shaped steel brackets connected by sheet metal with rivets and bolts, and looked like the 'jacks' that children play with. The brackets were about 1.8m long and the hedgehog weighed over 180kg. They were used to close gaps or form a continuous line. At first, the Czechs deployed a row of concrete hedgehogs in front of a row of steel ones. Barbed wire was strung between and in front of these antitank barriers. Sometime after 1936, the concrete hedgehogs were replaced with steel posts sunk into concrete. As a rule, a row of steel posts was placed in front a row of steel hedgehogs. These obstacles were supplemented with copious amounts of barbed wire. The army used similar obstacles to back antitank ditches.¹⁸ The various combinations of antitank obstacles were labelled Type 'A' Old, 'A' New, 'B1', 'B2', and 'C'.

Czech Weapons and Armour for Fortifications

The Skoda Works were instrumental in making the Czech Army one of the best equipped in Europe by supplying it with modern weapons ranging from rifles and machine guns to artillery and tanks. Skoda also developed a number of special fortress weapons, including three types of breech-loaded mortars. However, the 90mm and 120mm mortars were not yet ready for service in 1938.

Skoda also created a special fortress model of antitank gun, the 47mm,¹⁹ which was adapted to the mount for a heavy machine gun. Before 1940, the Germans removed these 47mm cannons and their cloches to install them in their own fortifications.

The Zbrojovka Brno (ZB) Company manufactured automobiles and firearms. In 1923, its designers created the light air-cooled machine gun ZB vz 26, which evolved into several other types, including the Bren gun in England. The French FM 24/29, which became the primary infantry weapon in French fortifications, was also based on the ZB vz 26. ZB also developed the heavy machine gun Mle 35 on its own initiative in 1930 to replace the water-cooled Austrian Schwarzlose Mle 7/12 (produced as the Mle 7/24 by the Czechs) from the Great War period.²⁰ Mle 35 was modified in 1935 for ROP and became Mle 37. The Czechs exported these machine guns, some versions of which were built under licence in Great Britain (the BESA used in armoured vehicles), while the German Army used them after occupying the Czech nation.



German Post card from Nov. 1938 stating the Czech fortifications similar to the Maginot Line (on the back).



Frei trotz aller Tyrannie!

Models of a Czech interval casemate different than the one in the post card. (Prague Museum)



Courtesy of Bernard Lowry

A model of a Czech infantry casemate at Prague Museum and a 1938 German postcard showing a line of Czech bunkers. (Photographs and postcard courtesy of Bernard Lowry)

<i>ROP Code</i>	<i>Czech Abbrev.</i>	<i>Item with Czech Abbrev.</i>	<i>Manufact. Code</i>	<i>Notes</i>
	LK	Light machine gun		
	TK	Heavy machine gun		
	PTK	Antitank cannon		AT gun
N		LK mle 26	ZB vz. 26	
D		TK mle 37	ZB vz. 37	
M		Twin TK mle 37	ZB vz. 37	
U		50mm Mortar	Skoda B10	Fortress breech loaded
G		90mm Mortar	Skoda B7	Fortress breech loaded
		120mm Mortar	Skoda B12	Fortress (turret) breech loaded
Q	d4	47mm PTK	Skoda A6	Fortress AT gun
L1	d4-l	47mm PTK and TK	Skoda A6	Fortress AT gun mounts MG
L2	d3-k	37mm PTK and TK	Skoda A10	Fortress AT gun mounts MG
X		76.5mm Cannon	Skoda E5	Listed as 8cm (or 80mm)
Y		100mm Howitzer	Skoda F3	Fortress model

<i>ROP Code</i>	<i>Item with Czech Abbrev.</i>	<i>Range in Metres (Min/Max Range)</i>	<i>Rounds per Minute</i>
N	LK mle 26	1,600	600
D	TK mle 37	2,500	550
M	Twin TK mle 37	2,500	750
U	50mm Mortar	60/800	40
G	90mm Mortar	300/4,400	25–30
	120mm Mortar	250/7,500	12
	37mm PTK	6,000	
Q	47mm PTK	5,800	35
X	76.5mm Cannon	12,500	15–20
Y	100mm Howitzer	11,950	15–20

Like the French, the Czechs used a minimum of weapon types in their fortifications. Both used a light machine gun and a set of twin machine guns, but the Czechs also used a heavy machine gun.²¹ Both used 37mm and 47mm antitank guns, but the French switched to the larger 47mm weapon before 1936. The Czechs continued to use the 37mm mainly as a matter of economy, but they installed them only where tanks were not likely to appear.²² The French used the 75mm cannon and howitzer as the main artillery for the Maginot forts, but the Czechs worked on a 76.5mm gun and a larger 100mm howitzer. In 1938, tests showed that only the larger howitzer was more suitable for their purposes. However, neither weapon was ready in time. The French also used a special 135mm weapon that was more similar to a howitzer than to a mortar. It was mainly an antipersonnel weapon and probably similar to the Czech 120mm mortar. The Czechs produced a 90mm mortar for casemates similar to the 81mm mortar the French used in casemates and turrets. They intended to use them only in casemates, but not in those at Tvrz. Finally, both used their own version of a 50mm breech-loaded mortar in cloches.

All the machine guns used the same calibre of ammunition, 7.92mm, which simplified logistical support. The fort artillery required only two types in addition to rounds for the 47mm guns and the 50mm mortars.

Three Czech companies handled the construction of cloches, turrets, and other armoured components: Vitkovické Iron Company (VZ),²³ Třinecké železářny Mining Metallurgical Society Třinec (BH),²⁴ and Skoda Pilsen (S). Of over 790 cloches and turrets the army ordered from these companies before September 1938, several were actually delivered and installed. In addition to the armoured embrasures placed in the concrete walls of a casemate for mounting weapons, the Czech industries produced the armoured ventilation air intakes and exhausts that fit into the roofs like cloches. These intakes came in three different sizes ranging in diameter between 17.5cm and 35cm.

The Czech Army maintained a simple codename system for identifying the armament used in its fortifications. This system is used in most books today to describe 1930s-era weapons. The weapons table (below) displays the ROP codes. The table below includes ROP codes for fortifications.

<i>ROP Code</i>	<i>Item Czech Term and/or Abbrev.</i>	<i>Item</i>	<i>Notes</i>
CE	Kasemate pech. Srub	Infantry casemate or blockhouse	
EC	Kasemata del. Scrub	Artillery casemate or blockhouse	
OR	Kul. Otocna vez	MG turret	
RO	Delova Otocna vez	Artillery turret	
AJ	Zvon	Cloche*	For close defence and observation
JA	Kopule	Cupola (cloche)*	For long-range fire
TO		Heavy fortifications	
LO		Light fortifications	
	Zp – (pozorovací zvon)	Observation cloche	
	Zlk – (zvon pro lehký kulomet)	Cloche for light machine gun	
	Zk – (zvon pro těžký kulomet)	Cloche for heavy machine gun	
	Kk – (kopule pro těžký kulomet)	Cupola for heavy machine gun	See note*
	K2k – (kopule pro dvojče těžkých kulometů)	Cupola for twin heavy machine guns	See note*

* The Czechs identified cloches with long-range weapons (heavy or light machine guns) as ‘cupola’ instead of ‘cloche’. These were considered offensive positions.

The Skoda Works prepared for the construction of the machine gun and howitzer turrets for the forts during the second part of 1938, a little late for the Munich Crisis. Skoda was also to produce the fortress weapons, except the machine guns. The artillery turret was to mount a pair of 120mm howitzers, after the smaller weapon failed to meet requirements. The armour, similar to the French, was made of nickel-chromium-molybdenum steel that increased its strength. However, none of the artillery weapons or turrets was ready at the end of 1938. Skoda managed to build a single machine-gun turret, which was not installed in any fort.

The Czechs divided cloches, which came in several sizes, into two categories: cloches and cupolas. They used the term ‘zvon’ (bell) for observation and/or defensive weapons – usually light machine guns and 50mm breech-loaded mortars. The term ‘kopule’ (cupola),²⁵ on the other hand, referred to the domes used for long-range or offensive fire with heavy machine guns and usually included only one or two weapons embrasures.

The machine-gun turret housed a pair of heavy machine guns and rotated but did not retract. There were four gun/howitzer turrets, which would have mounted a pair of guns and retracted, under construction at Skoda when the Germans took over. One was about 85 per cent complete and a second nearly 70 per cent complete. The 120mm mortar position, first conceived as a turret, evolved into something best described as an armoured shield. It would have appeared as a large fixed armoured dome, much larger than a cloche that would have housed a special mounting for a pair of 120mm mortars inside. The mortar tubes attached to a circular piece in the roof of the shield rotated with the mortar mounting so that the weapons turned within the position. Only a wooden mock-up was completed.

Czech Turrets Versus Maginot Line Turrets

<u>Czech</u> <u>French</u>	<i>Interior Diameter</i>	<i>Roof/Wall Thickness</i>	<i>Weight</i>	<i>Remarks</i>
<u>100mm How</u>	3.2m	350mm/300mm	420 tons	<i>Retractable</i>
75mm Gun*	3.4m	350mm/300mm	265 tons	Retractable
<u>120mm Mort.</u>	3.5m	<i>Up to 400mm</i>	154.5 tons	<i>Fixed</i>
81mm Mort.	1.75m	300mm/300mm	125 tons	Retractable
135mm LB**	2.3m	300mm/300mm	165 tons	Retractable
<u>Machine gun</u>	1.5m	300mm/300mm	83.7 tons	<i>Non-retractable</i>
Machine gun***	1.38m	300mm/300mm	96 tons	Retractable

* This was for the 75mm Mle 1933. The Mle 1932R had 300mm thick roof armour and a diameter of 2.44m.

** LB or Lance Bomb was a weapon with characteristics similar to a mortar and howitzer, but fired a round that left behind a shell like a howitzer.

*** The French also had mixed arms turrets for a MG/25mm gun combination. There were two types of these and one was a conversion of the MG turret (see *Maginot Line: History and Guide* for more details).

In the French Maginot Line forts, rotating eclipsing turrets were used with the exception of some old Mougin turrets in the Alps. The Czechs, like the French, appropriated limited funds and strove to produce the most economical weapons. ROP planned to install twelve of the 120mm mortar positions in the forts and five more in independent artillery bunkers in South Moravia. It also planned to use five machine-gun turrets in the forts and an unspecified number

in several independent infantry casemates. Each of the fifteen forts was to have one howitzer turret, except for Babi, which was to have two.

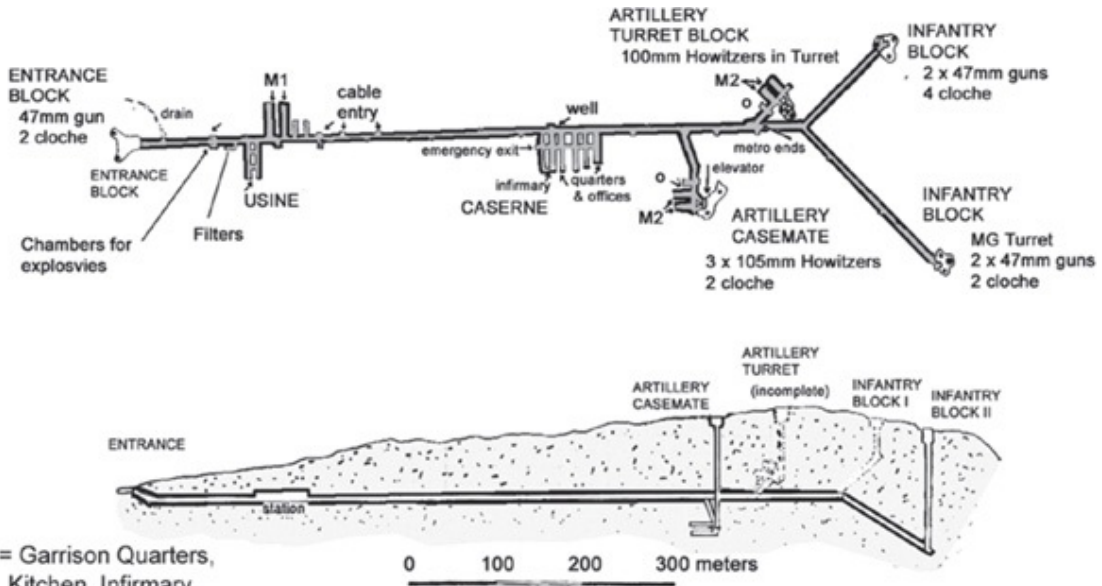

Caserne = Garrison Quarters,
Kitchen, Infirmary
M1 = Main Magazine
M2 = Magazine below
Artillery Blocks
o = offices
Usine = Engine Room & Fuel Stores
WC (latrines) at Caserne & and in &
below all Blocks.

CZECH FORT HURKA (BERGHÖHE)

Still Unfinished in September 1938

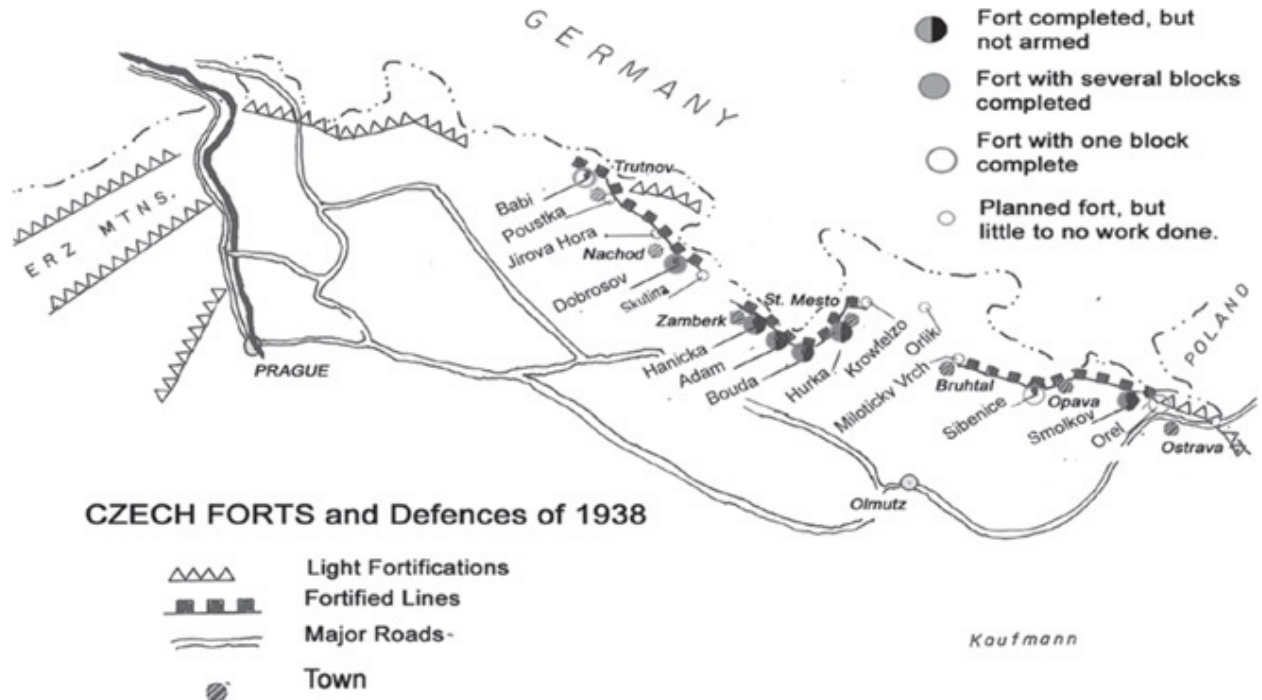

CZECH FORTS and Defences of 1938

- Light Fortifications
- Fortified Lines
- Major Roads
- Town

A plan of Fort Hurka and a map of the Czech Main Line showing the status of the forts in 1938.

The Beneš Line: The Czech Maginot Line

The Czechs began the construction of a 200km-long line of heavy fortifications in the style of the Maginot Line between Ostrava and Trutnov. The fortified line also included a number of light and medium bunkers that formed a complete barrier of interlocking fields of fire and covered a line of obstacles. This line and the planned forts were within 10km of the border. However, in a few cases, the tvrz. (forts)²⁶ were to be located within 2km or even 1km from the border and some fields of fire from their artillery covered a few kilometres of German territory.²⁷

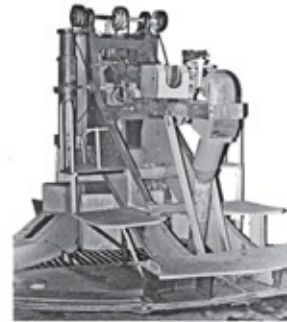
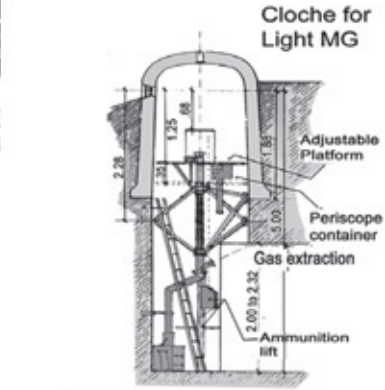
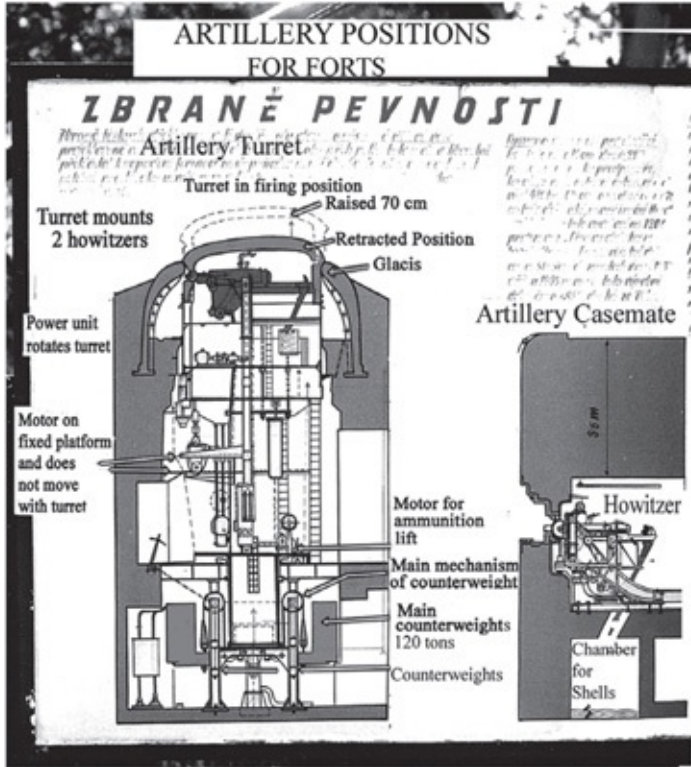

100mm Howitzer Casemate Mount

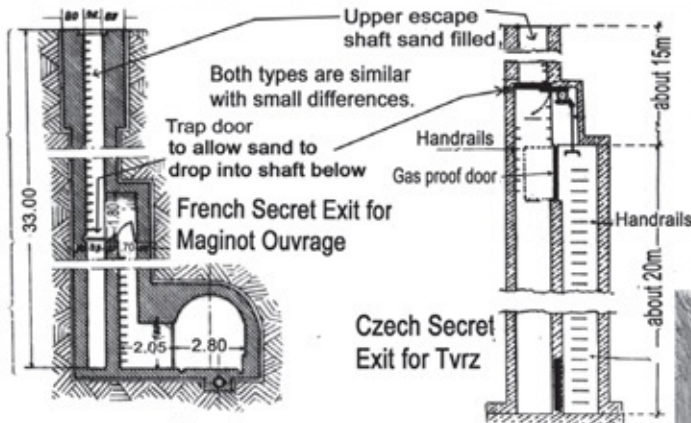

Components of a Trvrz

Exit found on many casemates with a fossé and may be on upper or lower level of block

This type exit is virtually the same as the French and used for patrols and guards on the fort's surface.

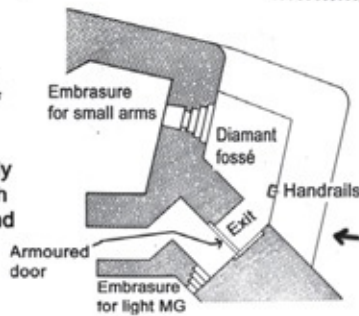

Similar exit

Blocks of Czech Tvrz of Bene's Line

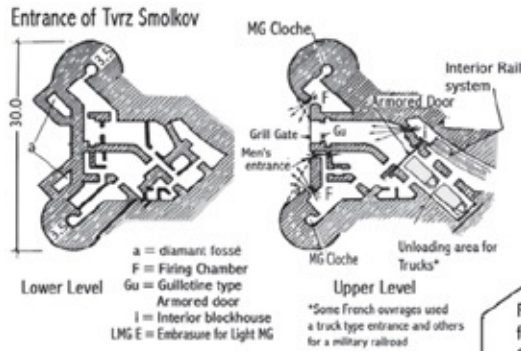

Blocks of French Ouvrages of Maginot Line

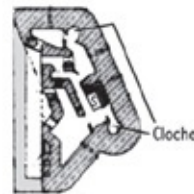
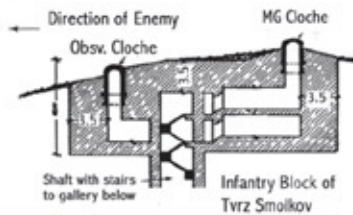
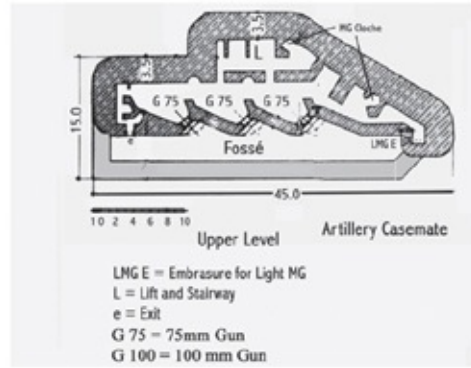
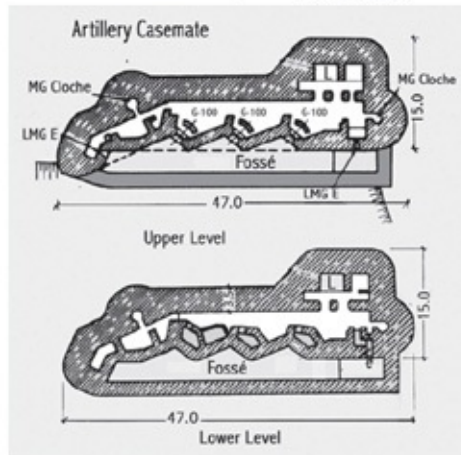

French and Czech Infantry Blocks came in several types. Some like the Czech example had only Cloche, others, like the French example had a Casemate position and cloche

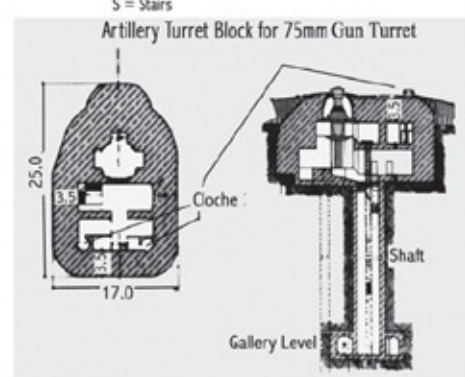
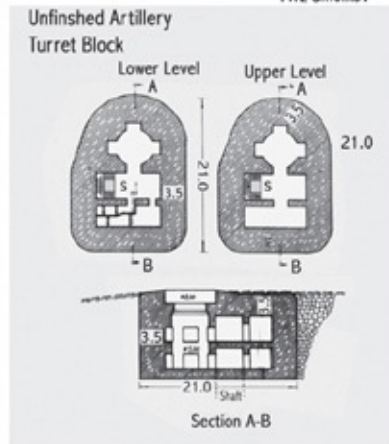

Kaufmann

The construction of the first five forts began in 1936. It included Forts Smolkov in February, Hurka and Adam in August, Hanička in September, and Bouda in October. The project was expected to end in mid-1939. Contracts went to Czech construction companies. Today, the Czechs claim that security was tighter than it had been in France. It appears that much of the German intelligence came from ethnic Germans in the Sudetenland and observation posts across the border since the Czechs built many of their fortifications within view of observers in Germany. The second phase of construction began in 1937 at Dobrošov, Babi, and Skutina between September and November, and Sibenice in April 1938. Completion of these forts was estimated for the autumn of 1940 and early 1941. The first five forts neared completion by the end of the summer of 1938, but lacked much of their equipment and artillery.

Czech Forts of the B'enesLine as Originally Planned

<i>Trz. (Fort) – Construction Work (Minus Armour)</i>	<i>Number of Blocks</i>	<i>Cloches/B10/B12/OR*</i>	<i>Garrison (Estimate)</i>
Orel – no work done	6	12/1/1/0	405
Smolkov – completed	5	11/1/0/0	394
Sibenice – not completed	8	15/1/1/0	615
Milotičky Vrch – cancelled	5**	9/1/1/0	?
Orlik – no work done	5	9/1/1/1	?
Kornfelzov – cancelled	7**	14/1/1/0	561
Hurka (Vysina) – completed	5	10/1/0/1	424
Bouda – completed	5	11/1/0/0	316
Adam – completed	8	16/1/1/1	611
Bartosovice – cancelled	?		
Hanička – completed	6	14/1/0/0	426
Skutina – not completed	6***	13/1/1/0	484
Dobrošov – not completed	7****	15/1/1/0	571
Jirova Hora – no work done	9	20/1/1/0	650
Poustka – no work done	10	18/1/1/1	700
Babi – not completed	11*+	23/2/2/1	778
TOTAL Planned: 16 (incl. 3 cancelled)	Over 100	210+/16/12/5	6,900+

* Cloches /B10 (Howitzer Turret)/B12 (120mm Mortar/OR (MG turret).

** Some work done.

*** Work on two blocks.

**** Work on three blocks and galleries.

*+ One block near completion, another barely begun, and work on galleries.

Czech Forts of the Beneš Line as Planned

<i>Trz. (German Name)</i>	<i>Work Begins (Estimated Completion)</i>	<i>Artillery Casemates (Main Wpn)</i>	<i>Artillery Turret (Main Wpn)</i>	<i>Infantry Block** (Main Wpn)</i>	<i>Entrance Block (Main Wpn)</i>
Orel	Project postponed	–	Mortar Howitzer	3 (47mm)	1 (47mm)
Smolkov (Harbiner Berg)	26 February 1936 (Early 1939)***	1 (3 x 105mm)	Howitzer	1 (47mm) 1 obsv.	1 (47mm)
Sibenice (Galgenberg)	30 April 1938 (Early 1941)****	2 (3 x 105mm)	Mortar Howitzer	3 (47mm)	1 (47mm)
Milotičky Vrch	Work not begun	–	Mortar Howitzer	1 (47mm) 1 (JM)	1 (47mm)
Hurka (Berghöhe)	8 August 1936*** (Autumn 1939)	1 (3 x 105mm)	Howitzer	1 (47mm) 1 (MG Tur)	1 (47mm)
Bouda (Baudenkoppe)	1 October 1936*** (Autumn 1939)	–	Howitzer	2 (JM) 1 (cloche)	1 (MG)
Adam (Adamsberg)	10 August 1936*** (Autumn 1939)	2 (3 x 105mm)	Mortar Howitzer	2 (47mm) 1 (MG Tur)	1 (47mm)
Bartosovice	Cancelled*				
Hanička (Panske Pole/Herrenfeld)	14 September 1936*** (Autumn 1939)	1 (3 x 105mm)	Howitzer	3 (MG)	1 (MG)
Skutina	18 November 1937	1 (3 x 105mm)	Mortar Howitzer	2 (47mm)	1 (47mm)
Dobrošov (Dobroschow)	13 September 1937**** (Autumn 1940)	2 (3 x 105mm)	Mortar Howitzer	2 (47mm)	1 (47mm)
Jírova Hora	Work not begun	2 (3 x 105mm)	Mortar Howitzer	4 (47mm)	1 (47mm)
Poustka	Work not begun	2 (3 x 105mm)	Mortar Howitzer	4 (47mm) 1 (MG Tur)	1 (47mm)
Babi (Trautenbach)	16 October 1937**** (Autumn 1940)	2 (3 x 105mm)	2 Mortar 2 Howitzer	3 (47mm) 1 (MG Tur)	1 (47mm)

* Replaced with Hanička.

** Some of these infantry blocks included 47mm and JM (JM = Twin Machine Gun). MG Tur = Machine-gun Turret.

*** Largely completed but still needing outfitted and turrets are artillery pieces not installed.

**** Largely unfinished with some blocks and tunnels in various stages of completion. Cloche – only cloches (most blocks had cloche for observation and weapons). Artillery casemates were to have 3 x 105mm howitzers. Artillery Turrets had a 100mm howitzer, and Mortar Turrets had a 120mm mortar. Note: The forts with German names included were the only ones that had enough work done on them to be recognizable as forts, although Babi had only a single block built and little else.

Sources: Eduard Stehlik, *Lexikon Trzů: československého opevnění z let 1935–38* (Fort Print, 1992) and Emil Trojan, *Betonová Hranice: Concrete Frontier: Czechoslovak Frontier Defences* (OFTIS Company, 1995).

At Dobrošov, only one artillery casemate block and two infantry blocks were completed, but excavation of the tunnel system was far from complete. At Skutina, one infantry block was near completion, but excavation on the entrance

block was only in the early stages. At Babi, one infantry block was almost finished and work on the tunnel system was still underway. The military had to postpone construction of Orel, although one separate infantry block was ready by 1938.

Tvrz Bouda - Entrance



Tvrz Dobrosov - Arty Case.



Bouda - Inclined access to Main Gallery



Unfinished Gallery of Dobrusov



Tvrz Hanicka - Arty Case.*

Tvrz Babi - Unfinished Gallery

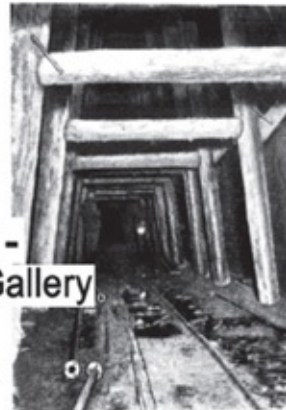

* One embrasure changed to car entrance by secret police in Cold War



Obsv. Block at Hanicka



Inf. Casemate at Babi



Unfinished entrance to Babi

Photographs of blocks and positions in Czech Tvrz. (Forts). (J.E. Kaufmann)

The design of the tvrz. was similar to the French gros ouvrage (large fort) of the Maginot Line, but it incorporated some of the more economical elements found in the French second phase of construction – the so-called Maginot New Fronts. Each fort was to have one entrance block for both munitions and troops.²⁸ The French built petits (small) and gros (large) or artillery ouvrages. The Czechs planned to construct only artillery forts seeing no point to a small fort without artillery. The tvrz. of six or more blocks were considered large whereas those with less than six were small even though all were artillery forts. Like in the French artillery forts, a main magazine also identified as the M-1, was located a short distance from the entrance block. The subterranean caserne often was several hundred metres away from the entrance and M-1 and generally near the centre of the fort. In the Maginot ouvrages, the combat blocks were normally concentrated in one or two groups, but occasionally there was an isolated combat block still linked by a gallery to the fort complex. The Czech forts seldom show a distinct grouping but in many cases they can be loosely divided into two groups, although there is not as wide a separation between these groups as found in the French ouvrages.

The distance between the caserne and the entrance block varied from 200m to 450m, whereas in most French ouvrages the distance was usually 100m to 300m. The Czech caserne was usually more centrally located and further from the M-1 magazine than in the French ouvrages. The distance between the entrance block and the combat blocks varied from 100m to 800m but was generally at least 300m, while the spacing in most French ouvrages was generally much greater at between 600m and 1,100m.

The distance between combat blocks in a group was normally between 100m to 150m, and about 200m for the projected tvrz. planned that were not built. Most Maginot ouvrage blocks had a separation of from 100m to 200m.

<i>Trz. (Fort) Planned (Completed Forts Below were Not Armed)</i>	<i>Distance from Entrance to Caserne*</i>	<i>Distance from Entrance to Combat Blocks*</i>	<i>Distance Between Most Grouped Combat Blocks**</i>
Orel – no work done	200m	400m	100m
Smolkov – completed	200m	200m	100m to 150m
Sibenice – not completed	550m	500m and 800m	300m
Hurka (Vysina) – completed	450m	700m	100m
Bouda – completed	300m	600m	100m
Adam – completed	200m	100m and 300m	150m
Hanička – completed	300m	300m and 500m	100m
Skutina – not completed	600m	600m and 900m	200m to 300m
Dobrošov – not completed	400m	400m and 600m	200m
Jirova Hora – no work done	400m	100m and 700m	200m
Poustka – no work done	200m	300m and 400m	200m
Babi – not completed	300m	500m and 300m	100m

* Distances are approximate.

** Not all groupings are distinct and distances are approximate and only represent majority of blocks in each group.

Source: Stehlik, *Lexikon Trzi*.

The entrance blocks were similar to the one of the French ‘New Fronts’ with a grating door at the front of the entrance hall and an armoured gate less than 2m behind it. A mechanism raised the armoured gate from below the floor to seal the entrance in front of it. About 10m behind the gates was a sliding armoured door that split in two sections as it retracted into both sides of the wall, also similar to the French. Between these armoured doors was a weapons position. Behind the sliding door, trucks were to unload in a 15m-long corridor adjacent to the gallery entrance where rail cars could be loaded. The rail cars used a track system that ran through the main gallery. However, there is no evidence anything more than manpower would be used to move these cars, whereas in the Maginot ouvrages there was often a small locomotive. Most entrances had a cloche for observation and a light machine gun on each side, like the French ones. On either side of the entryway, there was a casemate position for either machine guns or a 47mm antitank gun, and in front of most of these embrasures, there was a fossé diamant (diamond or angular shaped ditch) for protection. Only the entrances of Bouda and Hanička lacked an antitank gun. A tube in the wall known as a grenade launcher, similar to the French, served to drop grenades into the fossé. The

entrance blocks also had a lower level that included a filter and ventilator room, crew rest area, a radio room, WC, munitions, and other storage areas. Water emptied out of the fort through a drainage tunnel often located below or near the entrance, under the gallery floor. These drains could sometimes be used as an emergency exit if well protected, although where the water actually exited the size narrowed down.

Czech cable entries, exterior transformers near the entrance for using the local power grid, and underground telephone lines with inspection points were similar to the French. A short distance from the entrance block, in the main gallery, there was a pair of chambers on either side with space for explosives ready to detonate and seal the gallery. In many cases, the main gallery was below the level of the entrance block. At Bouda, for instance, it was reached by means of an incline; at Hanička, it was accessed via a staircase or a lift. The type of access was determined by the position of the entrance vis-à-vis the main gallery, which was usually at a depth of 30m. The French preferred a level approach, but used all three methods, depending on the terrain, which dictated the requirements.

The engine room (*usine*) and a chamber for filters and ventilators were located a short distance from the entrance, which facilitated the removal of exhaust fumes from the diesel engines. Most forts had three or four engines, no more than two of which were in service at the same time. Next came the M-1, the main munitions magazine for the fort. The caserne with crew quarters, kitchens, washrooms, offices, and other facilities occupied a central location, which was not the case in most French forts. All the forts required a water supply (cisterns and a well), fuel stores, and sufficient storage space for food, equipment, and other supplies. They also needed adequate radio and telephone communication, and effective internal communications. The filter and ventilator system were to keep the fort's subterranean sections and blocks protected from a gas attack in addition to circulating fresh air. Fresh air entered and foul air exited through a system of armoured air vents on the blocks. These items were necessities in any modern fort built in the twentieth century after the First World War.

Tactical needs and the terrain dictated the placement of combat blocks, whether grouped or not, so there was no standard layout for a tvrz. However, the designers followed certain principles such as placement of the entrance, magazines, caserne, etc. The features of the combat blocks, like those of the entrance blocks, followed the French formula of relative standardization, but the Czech engineers modified each to take advantage of the terrain and added their own innovations. Standard combat blocks were either infantry or artillery. Observation blocks were placed where needed. In one instance only, the observation block was actually connected to the underground system. The infantry blocks generally had two to three cloches and casemate positions on one or both flanks. Plans called for only five forts to have infantry blocks with a machine-gun turret. The number of infantry blocks, including a machine-gun turret, varied from one to five per tvrz. Only one fort, Smolkov, was to have only one and one fort, which was not built, was to have as many as five. Most forts numbered three infantry blocks. All the forts included a turret for a pair of 100mm howitzers, and all but Bouda, Hanička, and Hurka were to include an armoured shield for a pair of 120mm mortars. These three forts were also three of the five actually built. Every fort was to have an artillery casemate mounting three 100mm guns except for Orel, Milotičky Vrch, and Bouda. Babi, where only one infantry casemate was completed, would have had four infantry blocks, two howitzer turrets, two mortar turrets, and two artillery casemates, making it the largest tvrz. had it been built. It would also have been the last fort on the west end of the Beneš Line.

The Number of Cloches (Czech Cloche and Cupola) for Fifteen Planned Forts

<i>Forts</i>	<i>Arty Casemate</i>	<i>Gun Turret</i>	<i>Mortar Turret</i>	<i>MG Turret</i>	<i>Infantry Block</i>
No. of cloche	1	7	7	—	—
1 cloche	1	6	5	1	1
2 cloche	14	3	—	4	4
3 cloche	—	—	—	1	28
4 cloche	—	—	—	—	6
Total of 90	16	16	12	6	40

Notes: Of the projected forts, Orlik had no entrance planned and, apparently, its blocks would not be linked

underground since its purpose would have been to serve as a training site. No work was done on this fort.

Fort Smolkov was to have an observation block with two cloches. Four other forts were to have observation blocks without an underground gallery connection.

The Five Forts with Concrete Work Completed in 1938

<i>Forts (Five Completed Forts)</i>	<i>Arty Casemate</i>	<i>Gun Turret</i>	<i>Mortar Turret</i>	<i>MG Turret</i>	<i>Infantry Block</i>
Number of cloche*	–	2	1	–	–
1 cloche	–	2	–	3	–
2 cloches	5	1	–	–	1
3 cloches	–	–	–	–	6
4 cloches	–	–	–	–	2
Sub Total	5	5	1	3	9
Other forts**	1	–	–	–	4
Total of 28	6	5	1	3	13

* Includes both defensive cloche and offensive cupola.

** Not including the five completed forts, Dobrošov, Skutina, Sibenice, and Babi under construction had only about six blocks completed.

The types of cloches used on the blocks varied according to several standards, again following the French lead. The Czechs created a heavier and more solid cloche than the French did. The most common types were for a light machine gun, general observation, and a heavy machine gun. Several blocks of the tvrz. usually had an artillery observation cloche. The cloches mounting machine guns often had 360° coverage, which caused them to protrude above the block and to become exposed. However, they had the advantage of covering the front of the block. Infantry casemate positions normally had one embrasure for a light machine gun and one for a twin machine gun and a 37mm antitank gun similar to those in the French forts. The main difference was in targeting. The Czechs used a different system than the French. A pantograph, similar to the one used in Switzerland, was located above the machine gun to show where it was aimed. These casemate positions generally had fields of fire to the flanks and rear, preventing exposure to direct enemy artillery fire.

The retractable artillery turret planned for every tvrz. was to mount two 100mm howitzers and have avant-cuirasse (glacis armour) for additional protection like the French and Belgian turrets. The cupola for 120mm mortars

was an armoured shield, most of the which was embedded in concrete with the exposed part presenting a low profile and forming an avant-cuirasse with a diameter of 4.9m. A pair of 120mm mortars was to be set in a rotating embrasure in the centre of the fixed armoured shield and placed at a 45° angle. To adjust for range, the Czech gunners attached a varying number of charges to the mortar bomb and regulated the amount of gas released.

The artillery casemate mounted three 100mm howitzers, with angled embrasures similar in design to those of the Maginot Line, giving a 45° field of fire. A pair of cloches and a defensive embrasure covering the fossé gave defensive fire. The two-level block was accessed by a stairway and two lifts. One level had a protected emergency exit, which makes these casemates difficult to distinguish from their French cousins. However, the French guns could only fire to the flank with a 45° field of fire. An enemy in their field of fire was only presented with a small profile of the facade at which to fire back thanks to this design. For a full view of the facade, the enemy would have to position his guns behind the fort. The location of some Czech artillery casemates gave an oblique angle that covered part of the front and a flank. This angle in some cases may have exposed a small part of the casemate's facade to enemy frontal fire, whereas the French Maginot casemates were completely hidden from the front. Often, when two artillery casemates were not located so that their exposed facade faced the rear, their fields of fire crossed each other, a method not used in the Maginot Line. Thus, the Czechs had decided to expose the facades of some of their artillery casemates to enemy fire, but it may be that the terrain in front of the facade blocked them from direct fire. This innovation was an improvement over the French set-up.

All the artillery blocks had an M-2 magazine below them, like in the French Maginot Line. In the access gallery below, one or two lifts served to carry ammunition up to the block. The motor to operate the lifts was in a room next to them. The M-2 consisted of two large storage cells. The M-2 for the 120mm mortars consisted of only one large cell. Near the M-2, there was a group of offices, including radio and telephone communications rooms. Across from these offices was a niche for a ventilator. The galleries normally had a set of airtight

gas-proof doors. In the artillery block above, there was an M-3 magazine to maintain a ready supply of ammunition for the guns. Resupply for the M-2 magazine came from the main magazine, the M-1, linked to it by the railway running through the gallery. The M-1 consisted of several large cells, the number of which depended on the size of the fort. Infantry blocks did not require an M-2 magazine nor a lift, but the Czech designs included one nonetheless.

Some of the blocks for a machine-gun turret, which consisted of two levels, had a firing chamber for a 47mm antitank gun/heavy machine-gun combination and a twin machine gun. If there was a firing chamber, a fossé diamant was built in front of the embrasures. An embrasure for a light machine gun on the side covered the fossé. The other rooms in the block included one for communications, an ammunition magazine, a machine-gun ammunition magazine, an airlock, and a stairwell to the lower level. The turret was similar to the French, but it did not retract. The lower level contained a rest area and WC for the crew and usually a ventilator and filter. Plans show a small engine room and fuel storage apparently used to operate the turret and local power needs, whereas the French did not maintain separate power facilities in their blocks. Crewmembers could operate turrets manually if the power failed. Concrete thickness, rockwork back fill and most other elements were similar to the French designs. These blocks could include one or two cloches.

The three-gun artillery casemate followed a pattern closer to the second-generation French of this type. The upper level had room for little more than the gun positions and their ready ammunition, the stairwell, two lifts for ammunition, a water reservoir for cooling the guns, and a flanking chamber for a light machine gun to cover the fossé. The crew quarters, WC, and air filters and ventilators were on the lower level. These casemates usually had two cloches. The crew for the block and in the gallery below numbered about eighty-five men, including three officers.

The artillery turret block was somewhat similar to the machine-gun turret block except that the turret required a large amount of space. The counterweight for eclipsing the turret was below the first level, which contained the turret control room. A single lift located in the centre of the stairwell served for

hauling up ammunition. The upper level included an M-3 magazine for the 100mm howitzers and a storage area for machine-gun ammunition. In the turret control room were niches for ready ammunition. There was also a water reservoir and food stores on this level. The lower level had the filters and ventilator, quarters for the crew and commander, and latrine facilities. One chamber was located below this level that received expended shells from the turrets' guns from a chute leading from the guns down to this isolated room. The crew for this type of block was about fifty-five men including in the gallery below.

The block for the 120mm mortars in an armoured shield had a design somewhat similar to the other turret blocks. Since the mortars rotated on their mount within the armoured shield, a control room was not required. The upper level beneath the mortar position had an M-3 and a small engine room. Mortar ammunition was also stored near the stairwell and next to the crew quarters with bunks for six men. The filters and ventilator were on the lower level next to the quarters for two NCOs. The block also had a small supply store and the block commander's room. The crew and those in the gallery below amounted to about forty men.

The Czechs, unlike the French, did not create mixed infantry and artillery blocks. The only turret blocks that included casemate positions were those mounting a machine-gun turret. The infantry casemate blocks either had one or two firing chambers on each flank. They included similar facilities on both levels as the artillery blocks with some variation. The upper level comprised the firing chambers, munitions storage, communications room, the commander's room, a gas lock near the stairwell, and access to the cloches. Published plans indicate that the stairs went around a lift shaft in these blocks. There does not seem to be any logical reason why the Czechs would include an expensive feature like a lift when the French did not. At the lower level, there were crew quarters and other facilities. Often, there was also an exit that opened into the fossé for patrolling the surface of the fort. The majority of these blocks had three cloches, a few had four, and a small number had only one. The smaller infantry casemates with only one firing chamber had crews of about twenty-five men,

while those with two firing chambers may have needed up to forty men.

Entrance blocks had crews of about twenty men. The garrison required a number of specialists to operate and maintain the machinery and the engine room. The caserne area also needed other troops ranging from cooks to quartermasters. Since none of the forts was ready and none fully occupied, it is reasonable to assume that the Czechs would have used a system similar to the French according to which the garrison was divided into shifts like on a ship.

Each fort was to include an earth-covered, secret emergency exit that consisted of a vertical shaft filled with sand that could be released into another shaft below, allowing the men to climb out. Other features included emergency lights, internal defences, a ventilation system for protection against gas, medical facilities, kitchens, etc.

Although the Czechs built their forts rather quickly, the large armoured components and the special artillery pieces were not ready in time for the 1938 crisis. The antitank guns, machine guns, armoured embrasures, and cloches were ready for mounting, but in September 1938, the barely completed forts still missed essential components, much of their equipment had not yet been installed, and their interior work was unfinished.

Ready for War

The well-armed Czech military, with a core of veterans from the Great War, was ready to fight in the autumn of 1938. Among the elite troops were not only those who served in tanks, but also the fortress troops. Unfortunately, the weakest link was the Beneš Line and other fortifications that were months away from completion. At the time of the Munich Crisis, only five forts had been completed in the Beneš Line (Smolkov, Hurka (Výšina), Bouda, Adam, and Hanička) and were ready for their garrisons, but they still had no artillery or turrets or guns in place. The best the Czechs could do was to place a battery of 75mm guns in front of the artillery casemates. To the west of Ostrava, where the Germans planned a main thrust, Smolkov, a line of casemates, and the partially completed Orel stood in the way. Further to the west, there was a lightly fortified gap in the Beneš Line. Beyond it, there was a second fortified region extending from St

Mesto to Trutnov. The remaining four relatively complete ouvrages supported the line of casemates. However, the tvrz. not only lacked turrets, but several were missing entire blocks. Most tvrz. as well as many independent infantry casemates still had no cloches, including offensive cupola-type cloches. According to Libor Boleslav, a Czech researcher, only 383 cloches had been installed in over 500 completed fort blocks and infantry casemates. Since most casemate designs mounted two, it means that less than half of these structures actually had cloches in place.

The Czech strategy was simple. Although their military was modern and well equipped with tanks, artillery, and aircraft, taking the offensive offered no advantages unless it was a war directed against Hungary. After the annexation of Austria to the Third Reich early in 1938, the Czechs had a much longer border with Germany to defend. Any Czech offensive against Germany would be into terrain as rough as the one the Germans faced to invade Czechoslovakia. At the time, both armies were about equal, and terrain favoured the defender. In addition, since Germany had a larger population and greater resources than Czechoslovakia, an offensive war was out of the question, especially since the Czechs refused to trust Poland. Thus, a defensive strategy combined with reliance on their French and Soviet allies to turn the tide was the best choice. The mountainous terrain turned the nation into a virtual fortress, like Switzerland. However, behind this barrier, in Bohemia and Moravia, the terrain was more open making it easier to assemble and move reserves to critical points using interior lines of defence. The Czechs have been criticized for spreading their military along the mountainous border instead of concentrating their forces in a more central position. Loss of the highly defensible terrain would have put the Czechs at a serious disadvantage. If it happened, they planned for a fighting retreat across Bohemia and Moravia toward Slovakia. This border region was not like the Alps, but the heavily wooded mountains were sufficient to give the defender decisive advantage. However, the Czech terrain required more troops for defence than the much higher Alpine ranges of Northern Italy, Switzerland, and Southeastern France. The loss of the Sudetenland after Munich in 1938 proved the point, when the Czech Army had not been significantly weakened,

but was left holding terrain with few defensive advantages.

At mobilization, the Czech 1st Army deployed seven infantry divisions in Northern Bohemia and the 2nd Army put four additional divisions in Northern Moravia. Most of the Beneš Line fell under the 2nd Army. The 4th Army had one mechanized, one motorized, and six infantry divisions to secure the southern front. The 3rd Army, with three divisions, held Slovakia and the defences on the Hungarian border. The strategic reserve consisted of three mechanized divisions ready to react to any enemy breach of the line in Bohemia or Moravia. Border Defence Battalions and Border Infantry Regiments protected the twelve border areas (sectors numbered 31 to 42) with seven additional Defence Groups, since 1935. The following year the army grouped them into larger commands. The fortress troops and border units had ethnic Germans removed to prevent problems.

The occupation of Austria earlier in 1938 showed that the German panzer divisions, which were still forming, had to work out problems. In September 1938, about 1,200 German tanks in 3 Panzer divisions and a couple of light divisions were ready to fight. However, only about seventy of the tanks were Panzer III armed with 37mm guns and the remainder were Panzer I armed with machine guns and Panzer II with a 20mm gun. The Czechs had about 540 tanks, including 2 models that were eventually used by the Germans in their own Panzer divisions for more than 2 years after the takeover of Czechoslovakia in 1939. All the Czech tanks had a 37mm gun, but their armour was lighter than the Panzer III. As for other military equipment, the Germans held the advantage in aircraft, but not much else.

The German High Command was uneasy about the Czech fortifications and ordered its intelligence services to investigate them. In July 1938, their agents reported an acceleration and expansion of construction since the autumn of 1937 from the Ore Mountains to the Eagle Mountains, mainly on machine-gun bunkers. Much of the Abwehr (German Intelligence) information was fragmentary. It included reports on the construction of 'Werkgruppe Adam and Berghöhe' and Baudenkoppe (Bouda), which noted that the missing positions were concreted, probably referring to the turrets that had not been installed.

Other documents gave details on the construction of major positions at five sites in southern Moravia. The Abwehr wanted to know if the fortifications mounted 47mm, 75mm, and 100mm weapons and if the turrets would have 80mm (75mm) or 47mm guns. According to one report, a turret position poured at Wittkowitz (Czech Vítkovice located west of Trutnov) had a diameter of 6m for the turret emplacement. This might have referred to Babi, but the work there had not progressed that far yet.

Earlier in 1938, in March, the Abwehr had received reports on armour used in the Czech fortifications with details on the three types of cloches and the three manufacturers. According to one of these reports, Czechs added cork between the concrete and the armour for soundproofing. The agents also reported that the concrete had been poured for the blocks, but that no 'iron' (their term for the turrets) had been installed. The agents also described the manufacturing process of cloches and details of armour plates for embrasures produced at Vítkovice. Reportedly, the factory operated in three shifts, seven days a week, and produced sixty embrasures a day.

The agents gained information on forts and individual casemates including that the underground telephone cables that linked the positions were buried at a depth of 2m and protected with stone packing. They reported that no searchlights had been installed yet, but that the Czechs reinforced their obstacles with additional wire entanglements, double rows of concrete hedgehogs in some sections between Schatzlar and Goldenols (north of Trutnov and near the border) and other places, and that most of the Czech positions had consisted of little more than light machine-gun bunkers since 1936. They were aware of a major 'fortress' (Babi) being built behind this position. They also reported on new obstacles being deployed in the Glatz Basin from the vicinity of Forts Adam to Fort Hurka. According to them, this line of obstacles included a 4m wide antitank ditch, a 2m-high and 0.4-m thick concrete wall, a row of concrete hedgehogs, and in places the double steel beams 30cm thick. At that time, they found no wire obstacles or antitank minefields in the vicinity.²⁹ However, Czech sappers were training in the use of these mines and had already excavated the holes for them in some places. The Czechs had prepared bridges, road crossings,

and other critical points to receive demolitions. Although the German agents reported that there were no electrical barriers, rumours about 'high-voltage obstacles' persisted. One of the V-Men reported seeing a Czech experimental stone barricade built in 5 hours with rammed earth and layers of brick (20,000 bricks).

The reports of July and August also suggested methods of eliminating the Czech bunkers. One agent wrote that even though the concrete bunkers were extremely strong, their Achilles' was the permanently mounted gun with a narrow field of fire. In addition, he pointed out that the manually operated ventilation was inadequate. The grenade launchers in the walls presented another weak point. The best way to deal with the Czech positions, the intelligence agents thought, was for assault troops to work their way right up to the bunkers taking advantage of the dead space. After reaching the bunker, they would have to block quickly the outside of the grenade launcher tube with something as simple as a rock. Thus, if the crew dropped a grenade it would explode inward killing them. Another suggestion was to take a pickaxe and break through the periscope opening, assuming that no one would be targeting the soldier doing this. Alternatively, the assailants could cover the machine-gun embrasure with a simple board. The agents also thought that a trooper could work his way to the door and throw a grenade in. Smoke, gas grenades, or flamethrowers, they thought, would easily eliminate the crew.

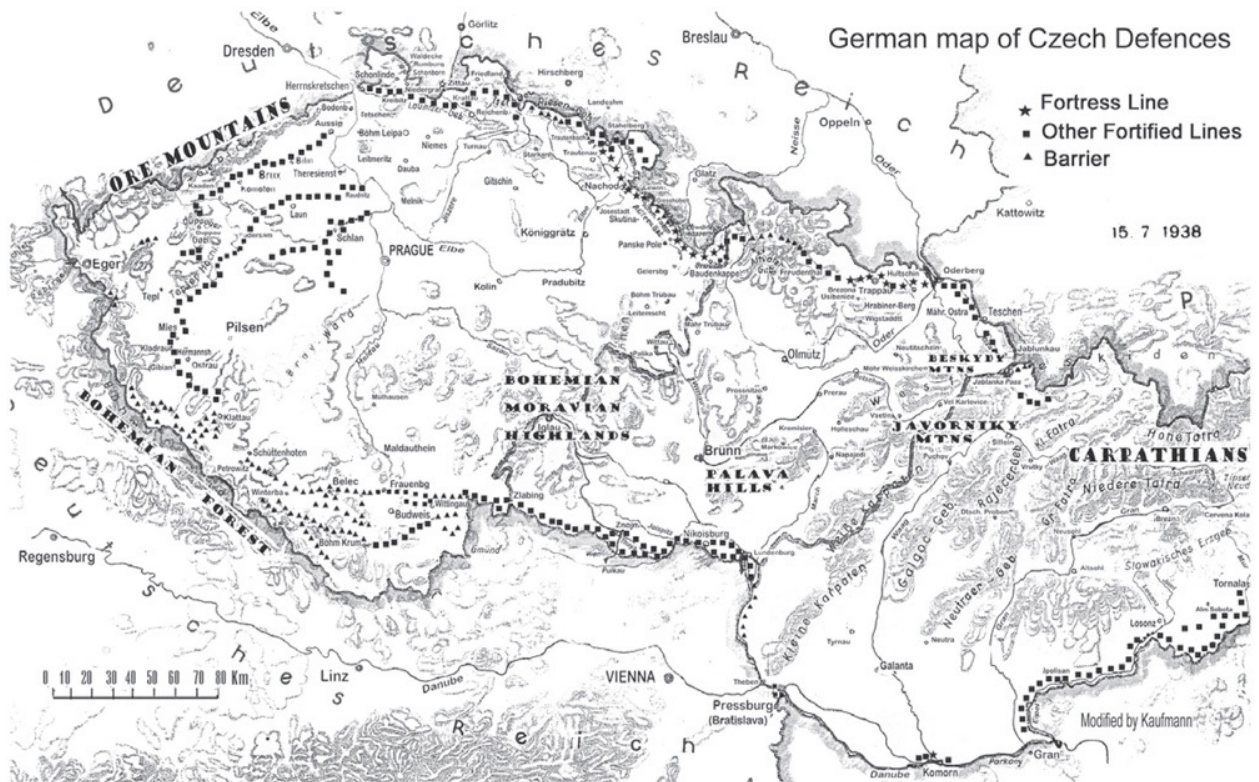

Czech defences based on a German intelligence map of 1938. The main line of defences and its location of forts are correctly marked along with most other border fortifications.

In August 1938, the German Army scrambled to assemble more details on the Czech fortifications. A report of 5 August included a description of new machine-gun bunkers in Lundenburg (Czech Břeclav) near the Austrian border in Moravia given by a deserter. They had walls 1m thick and were about 2.5m below ground. Their width was from 6m to 8m. The armament consisted of either one heavy or two light machine guns mounted on carriages. Each bunker included a ventilator, 2 periscopes, a crate with spare parts for the machine guns, 10 crates of munitions (12,000 rounds) and 4 boxes of M34 hand grenades (twelve grenades in each). These bunkers gave only flanking fires covering the distance between bunkers, which was 200m to 300m. The area between bunkers had been cleared and obstacles and wire had been added. The Czechs stored additional barbed wire in the barracks for use when war was eminent. They had crews of six men: two for each machine gun, two for the periscope, one with a rifle and grenades to defend the entrance, and one to operate the ventilator, which had to be done continuously to avoid suffocation. Normally, four men lived close by in a tent and one of them stayed on guard duty. One man was supposed to remain in the bunker, the deserter also reported, but the smell of creosote made it unbearable. The Czech Army had posted guards at each bunker on the first line and partially guarded the second line, up to 5km to the rear. At this time, additional bunkers were being built.

The members of the German High Command had mixed post-war opinions on the strength of the Czech fortifications. General Alfred Jodl claimed they were a serious obstacle, whereas General Wilhelm Keitel thought that the German 88mm flak guns would easily penetrate the bunkers. General Heinz Guderian was not impressed either. Later Keitel, like Erich von Manstein, claimed that Germany did not have the means to take on these fortifications. Today it is obvious that the far from complete Czech fortifications were, as Jodl stated, a rowboat compared to a battleship when matched against the Maginot Line. However, that rowboat could have impeded the German advance. Manstein's post-war reminiscences probably can give the most accurate glimpse of the German military establishment's view of the Czech fortifications and army in 1938.

The German plan, Case Green, called for several thrusts into Bohemia and Moravia. Since in normal circumstances an attacker should outnumber the defender, especially if the terrain was mountainous and/or included fortifications, the Germans had to commit almost their entire military force against the Czechs. This plan would have left the still unfinished West Wall lightly manned, pointed out General Wilhelm Adam, the German commander in the West. With barely more than a dozen divisions to hold it, the West Wall would not be able to resist a French offensive, Adam asserted. If the Soviets, who had made arrangements with the Rumanians for such a contingency, sent troops to support their ally, the Wehrmacht would get bogged down in the mountains surrounding the Czechoslovakia and get stuck in a stalemate. The German High Command realized the entire plan was too risky and some of its members plotted to remove Hitler if he decided to go to war. Earlier in late May 1938, when a crisis had developed during rioting in the Sudetenland, the Czechs had mobilized spoiling a key element to Hitler's plan, a pretext for war that would have allowed him to strike before the Czechs could assemble their forces. He wanted victory within a week, but the crisis rallied the French and British, forcing him to back down.

Dr Peter Grynier best summarized the events that followed. In August, when Hitler prepared again for action, Adam warned him that his limited forces might not be able to hold the West Wall. At a conference on 3 September, Hitler decided that the plan needed to be revised since it called for the German 2nd Army to strike the heavily fortified area where the Czechs were sure to have a force to counterattack. He was afraid that, like at Verdun, the 14th Army would get bogged down in Southern Moravia and fail to split the country. He wanted the main effort to centre on the 10th and 12th Armies advancing through the Bohemian Forest. Less than a week later, Hitler changed his mind again wanting the 2nd and 14th Armies to launch the main thrusts. Within days, he made demands, precipitating a new crisis. The Czechs began to mobilize on 23 September as French and British leaders flew back and forth from Germany. The negotiations culminated in the Munich Conference on 29 September. The Czechs were ready to fight and the Soviets were prepared to send 2 divisions and 300

tanks into Slovakia via Rumania, if the Western Allies decided to fight. Instead, the British and French backed down and forced the Czechs to cede the Sudetenland to Germany.

Speculation favoured an Allied victory, even if their military leaders performed in the same lethargic way they did in 1939. After the loss of the Sudetenland, the Czechs were left virtually defenceless and although their military remained strong, they were going to have to manoeuvre against a German invasion force in an unfavourable position. On 15 March 1939, German forces marched into the remnants of the Czech nation unchallenged. Weapons of the Czech Army found their way into German service including artillery and tanks. The tanks helped fill out several new German Panzer divisions. The Germans began removing some of the cloches for transfer to their own fortifications. Later, they built special bunkers specifically designed for the Czech 47mm antitank gun. They also conducted artillery tests against the Czech fortifications to develop techniques for attacking the French and Belgian fortifications. The Czech nation was the main obstruction to German expansion while it was allied with France, but that changed with a bloodless Nazi takeover.

Czech Army on Mobilization – September 1938

1st Army at Kutna Hora (about 50km east of Prague)

–I Corps at Votice – Border Area 32

2nd Division near Pilsen

5th Division at Pisek

Group 4 HQ at Votice

– Border Zone XI – Group 1 HQ at Rakovnik

– II Corps at Mlada Boleslav – Border Area 33

3rd Division at Mseno

17th Division at Ryschonov

– Border Zone XII – Border Area 34 and 35

– 18th Division near Bustgehrad (a few km west of Prague)

1st Fast Division (GR) at Pacov and 4th Division at Hradec Králové

and 13th (motorized) Division (GR) at Humpolec mobilizing

2nd Army at Olomouc

- IV Corps at Litovel – Border Area 36
- 7th Division at Zabreh
- Border Zone XIII at Hranice – Border area 37
- 8th Division at Moravsky Beroun
- 12th Division at Vsetin and 22nd Divisions at Zilina mobilizing
- 16th Division (GR) at Ruzomberok

3rd Army at Kremnica

- VII Corps at Vrable – Border Area 39
- Border Zone XV at Banska Bystrica – Border Area 40
- Border Zone XVI at Kosice – Border Areas 41 and 42
- 10th Division at Krupina
- 11th Division at Lovinobana
- 3rd Fast Division (GR) at Levice

4th Army at Brno

- VI Corps at Sobeslav – Border Area 31
- 4th Fast Division at Sobeslav
- III Corps at Hihlava
- Group 2 at Zeletava
- 14th (motorized) Division at Trest
- 19th Division at Trebic
- Border Zone XIV at Brno – Border Area 38
- 2nd Fast Division (GR) at Jarmoerice
- V Corps at Klobouky

6th Division at Pohrellice

20th Division at Mutenice

9th Division at Nove Mesto, 15th Division at Senica, 21st Division at Veseli

GR = General Reserve of the Army High Command.

Source: Pavel Sráamek, *Když Zemřít, Tak Čestně* (Friends of Czechoslovakian Fortification Publishing Co., 1998).



Maps showing the location of Czech forces in 1938.