



LÉKAŘSKÁ FAKULTA MASARYKOVY UNIVERSITY
Interní hematologická klinika LF MU a FN Brno
Centrum molekulární biologie a genové terapie



Metody analýzy microRNA

MUDr. Mgr. Marek Mráz

- Lidské miRNA geny: **cca 1000**

microRNA (miRNA)

- ❑ krátké RNA molekuly
~22 nukleotidů
- ❑ komplementární vazba k
cílové mRNA
- ❑ inhibují translaci a snižují
stabilitu mRNA

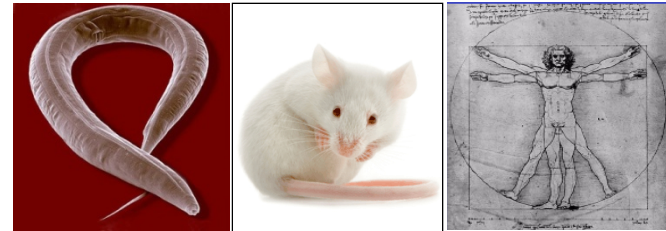

**Stovky evolučně
konzervovaných microRNA**

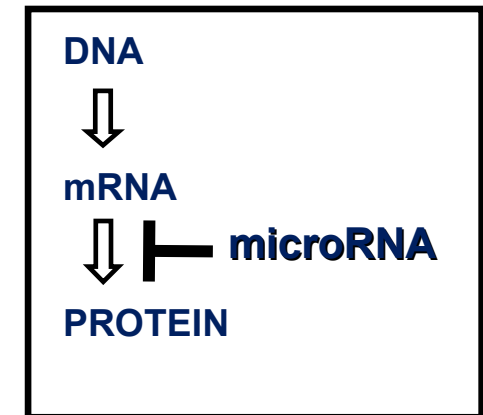
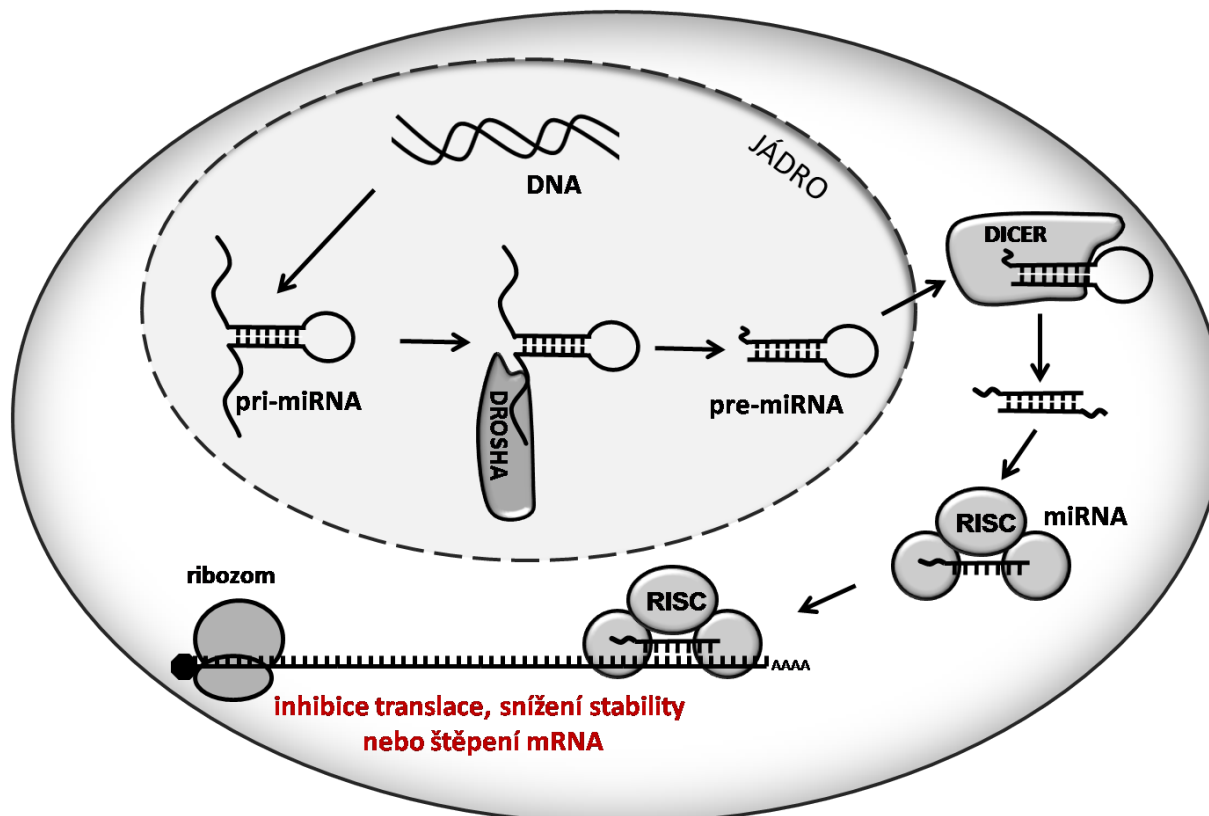

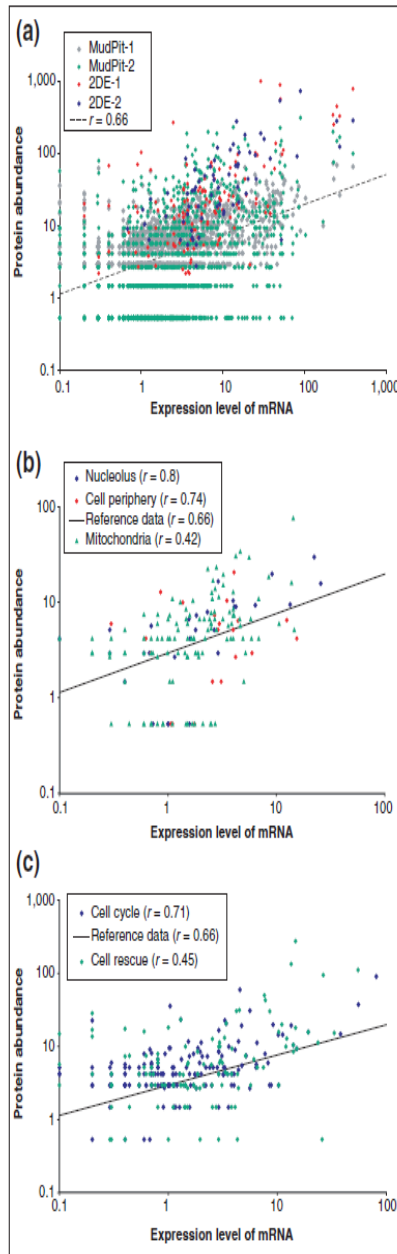

mRNA neznamená, že v buňce bude i protein

Historicky vždy velká neshoda mezi daty z expresních čipů a expresí proteinů (Western Blot)

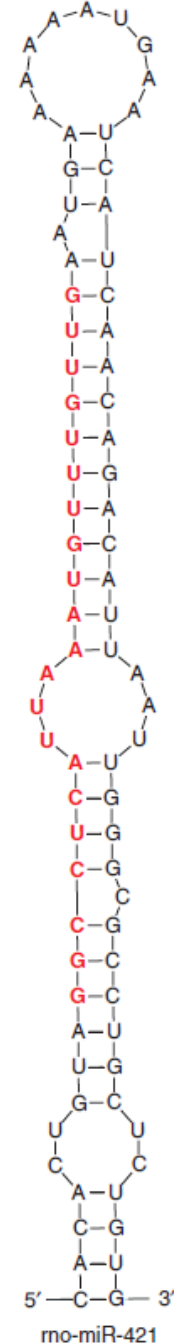
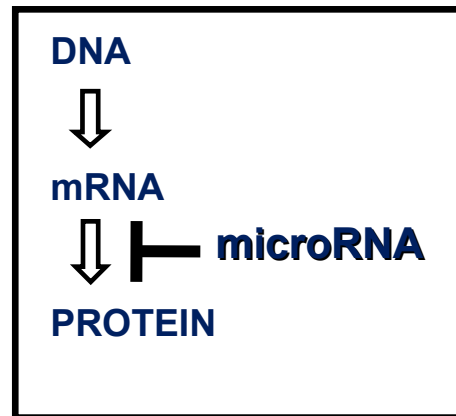

1/ Izolace a stabilita microRNA

Problémy: velikost 22nt, celkově cca 0,01% z celkové RNA

Izolace:

TRIzol/TriReagent
miRvana (Ambion)
PureLink (Invitrogen)
a další

Obohacení:

PAGE
FlashPAGE Fractionator
(Ambion)

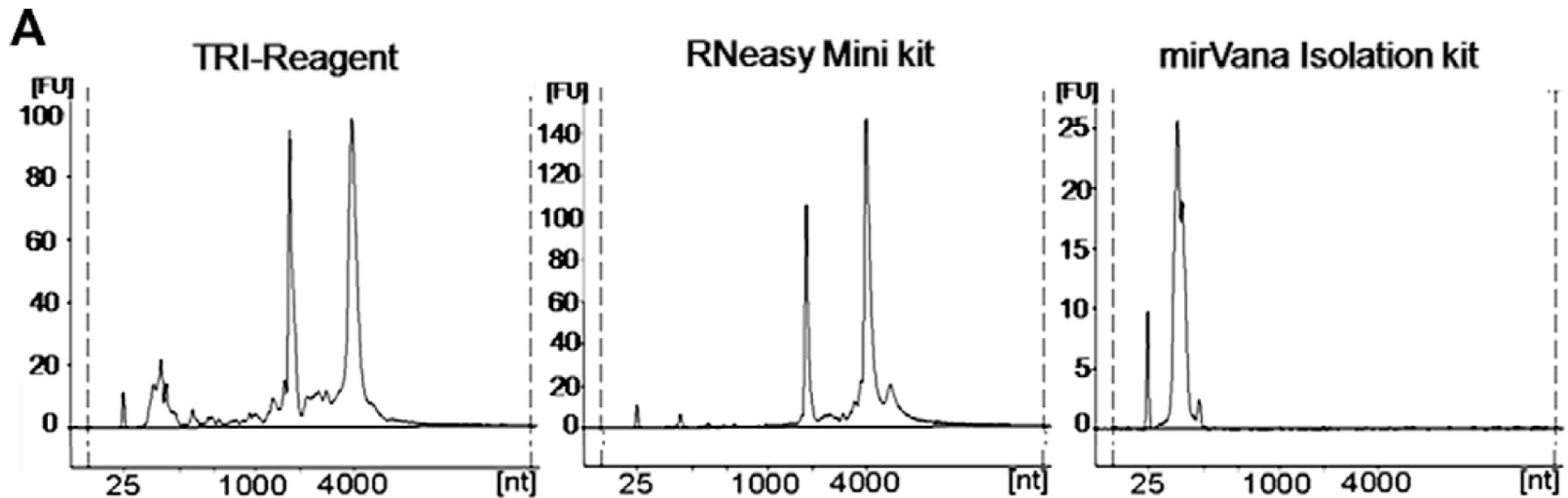

Mraz et al., 2009

Izolace:

TRizol/TriReagent
miRvana (Ambion)
PureLink (Invitrogen)
a další

Izolace:

TRIReagent/TRIzol
is the „gold standard“

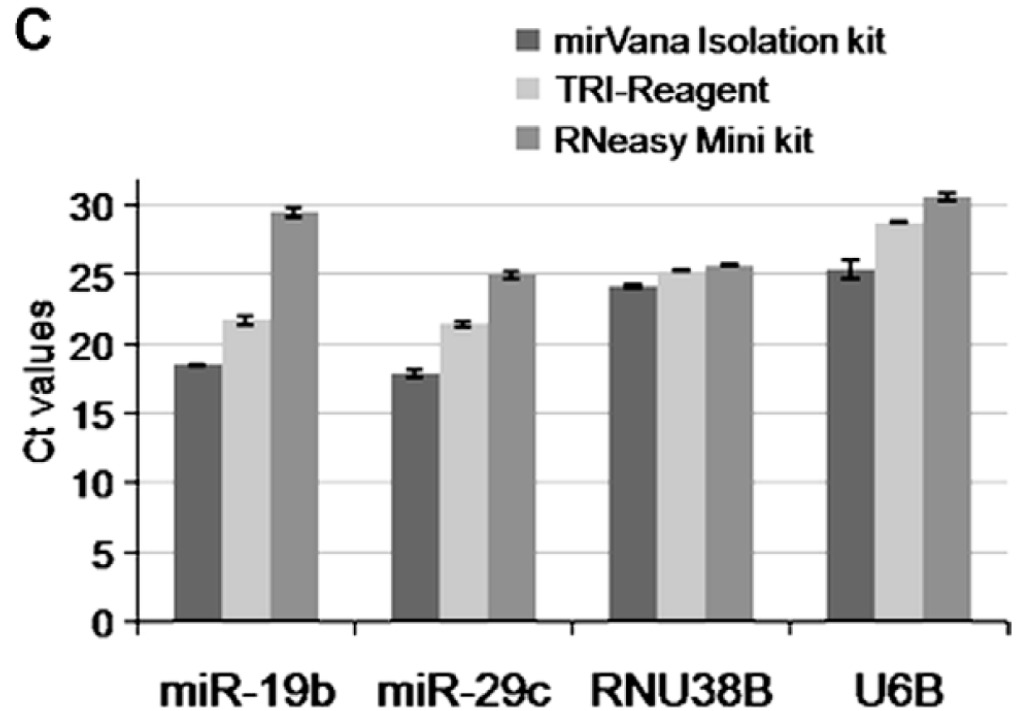
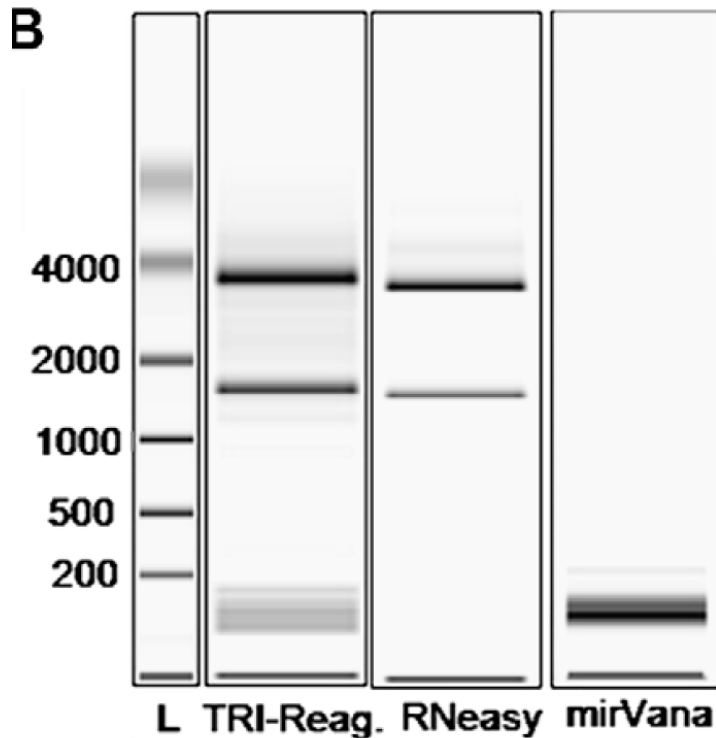
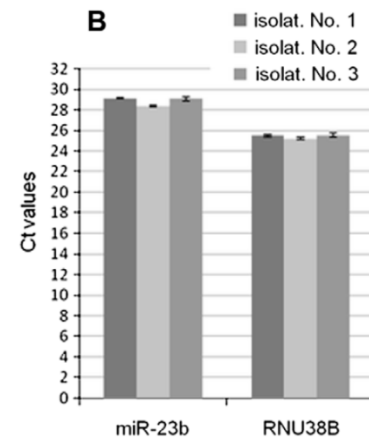

Obohaceni:

PAGE

FlashPAGE Fractionator (Ambion)



flashPAGE™ Protocol

1. Pipet flashPAGE™ Lower Running Buffer into the lower buffer chamber of the apparatus
<30 seconds
2. Insert a "ready-to-use," pre-cast flashPAGE™ Gel Cartridge
<5 seconds
3. Add flashPAGE™ Upper Running Buffer to the upper buffer chamber of the gel cartridge
<30 seconds
4. Add your RNA or DNA sample (with flashPAGE™ A40 Dye Marker)
<1 minute
5. Run gel at 70 V on any standard power supply
~12 minutes
6. Collect PAGE-purified nucleic acid from lower buffer chamber*
<30 seconds

Less than 15 minutes

Traditional PAGE Purification

1. Prepare gel solutions
30 minutes
2. Cast gel
2 hours
3. Pre-run the gel
30 minutes
4. Load sample
1 minute
5. Electrophorese
30-60 minutes
6. Stain gel to visualize region of interest
10 minutes
7. Excise desired size fraction
5 minutes
8. Soak crushed gel with elution buffer
overnight
9. Collect first elution and elute again
2 hours

22-24 hours

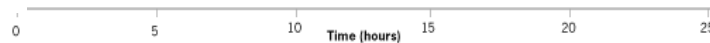

15min

20hours

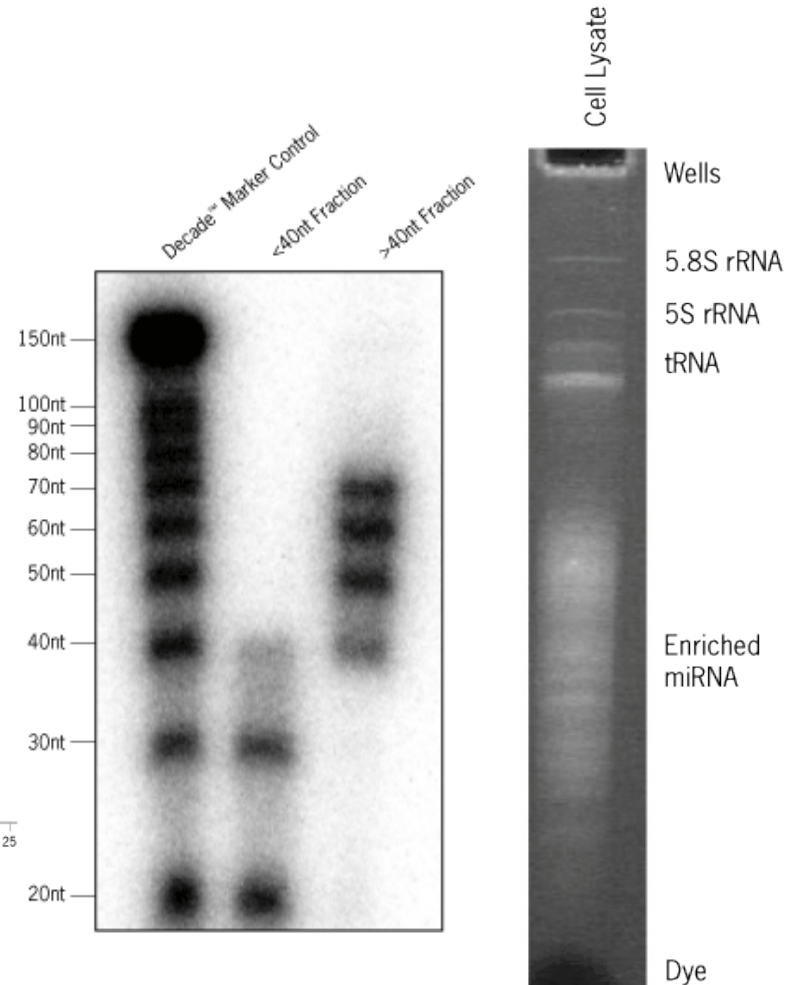

Stabilita microRNA :

Stabilita po izolaci

Stabilita v FFPE (formalin-fixed parafin-embedded tissue)

RNA

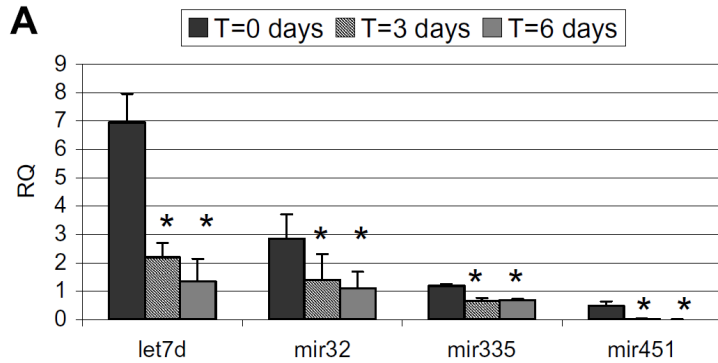

cDNA

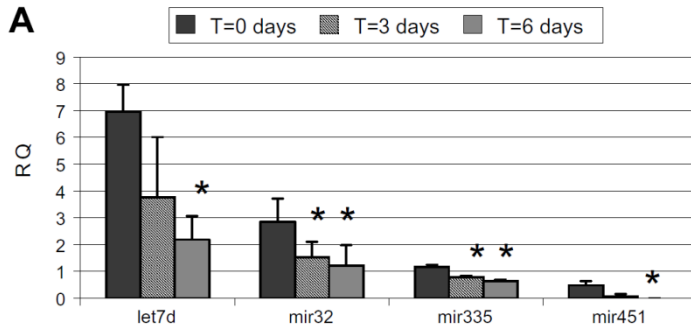

Bravo et al., 2007

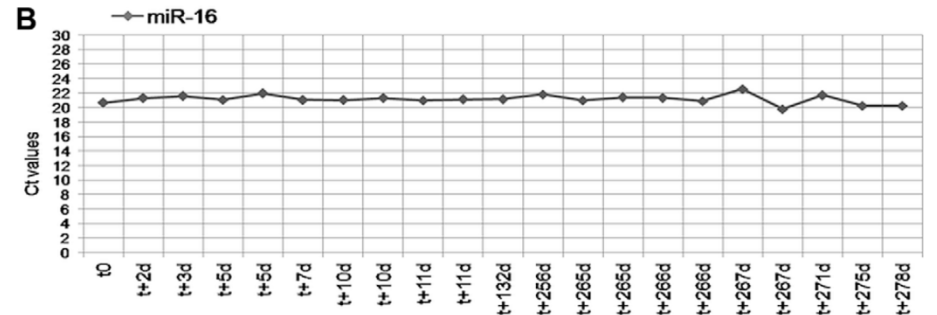
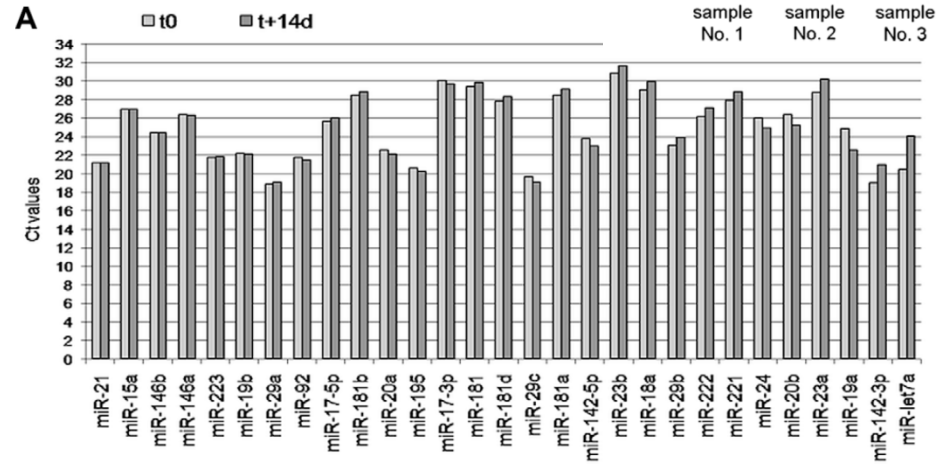
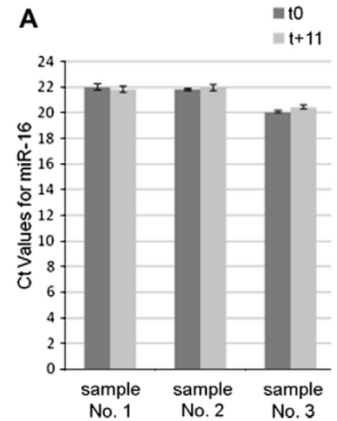

Mráz et al., 2009

Stabilita microRNA :

Stabilita v FFPE (formalin-fixed parafin-embedded tissue)

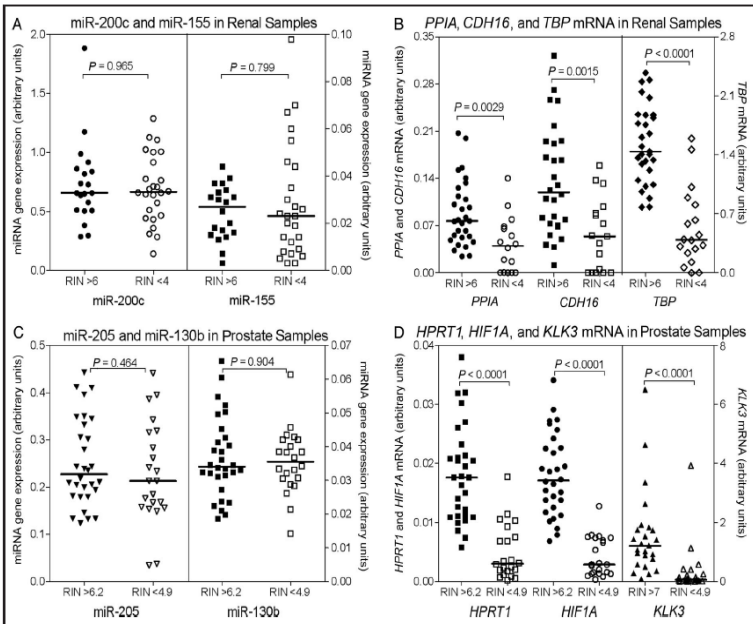
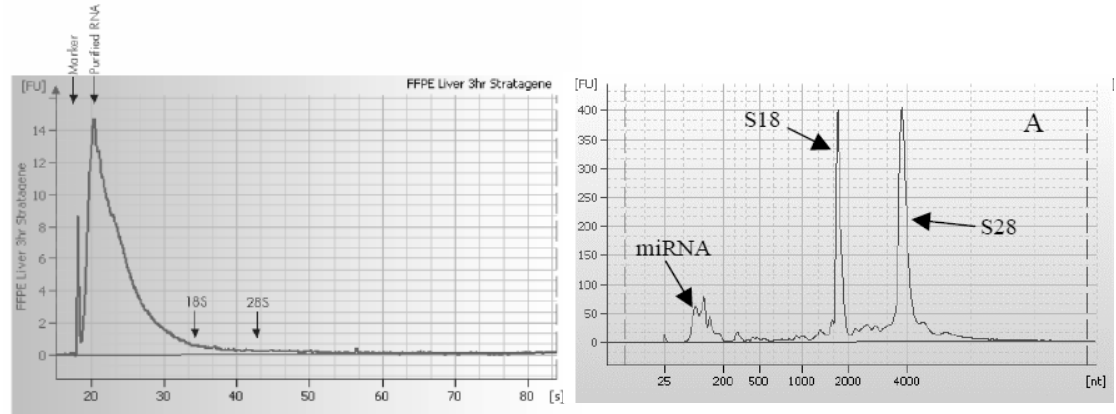
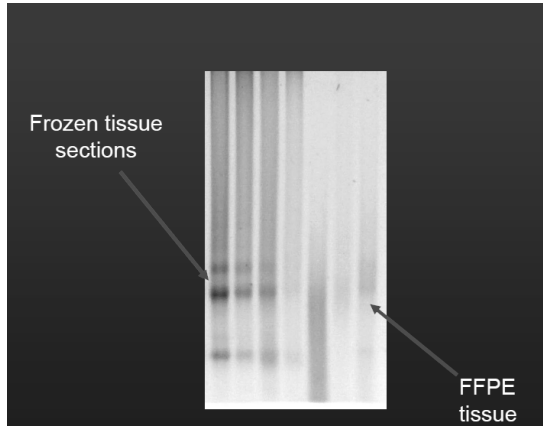

Fig. 4. Amounts of miRNAs and mRNAs in human nonpathologic, nonmalignant samples of renal and prostate tissues according to the RIN values of the isolated RNA.

The RIN study groups did not contain the same number of samples because of the limited availability of tissue material for testing. Amounts of miR-155 and miR-200c (A) and mRNAs encoded by the *PPIA*, *CDH16*, and *TBP* genes (B) in RNA samples with RIN values <4 (miRNA, n = 26; mRNAs, n = 18) and >6 (miRNAs, n = 20; mRNAs, n = 29) from renal tissue samples. miR-130b and miR-205 (C) and mRNAs encoded by the *HPRT1*, *HIF1A*, and *KLK3* genes (D) in RNA samples with RIN values <4.9 (n = 22) and >6.2 and >7.0 (n = 30 for miRNAs, *HPRT1* mRNA, and *HIF1A* mRNA; n = 25 for *KLK3* mRNA) from prostate tissue samples. Data are expressed as the median gene expression in arbitrary units. Statistical significance was evaluated with the Mann-Whitney U-test.

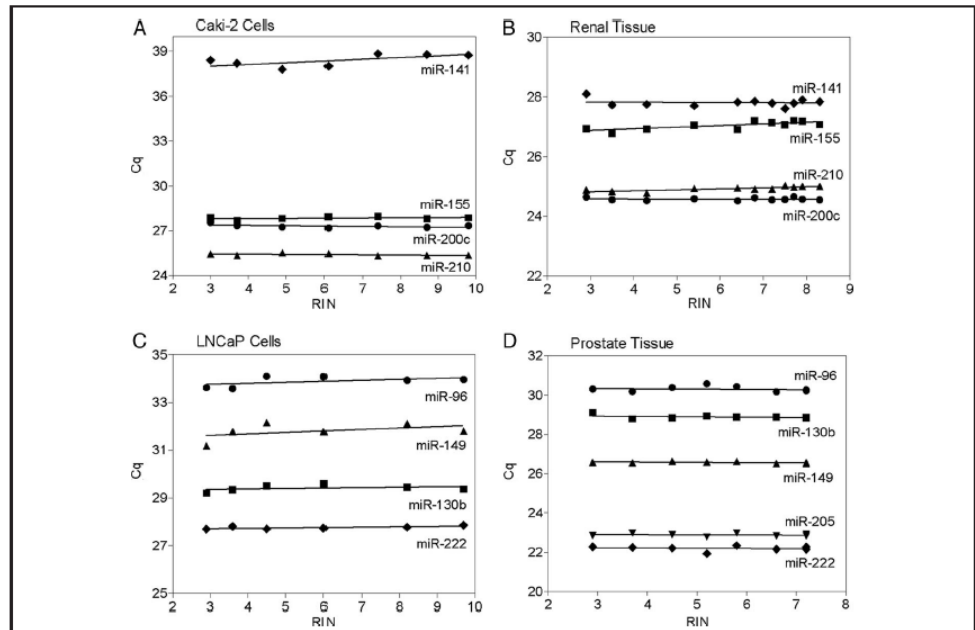
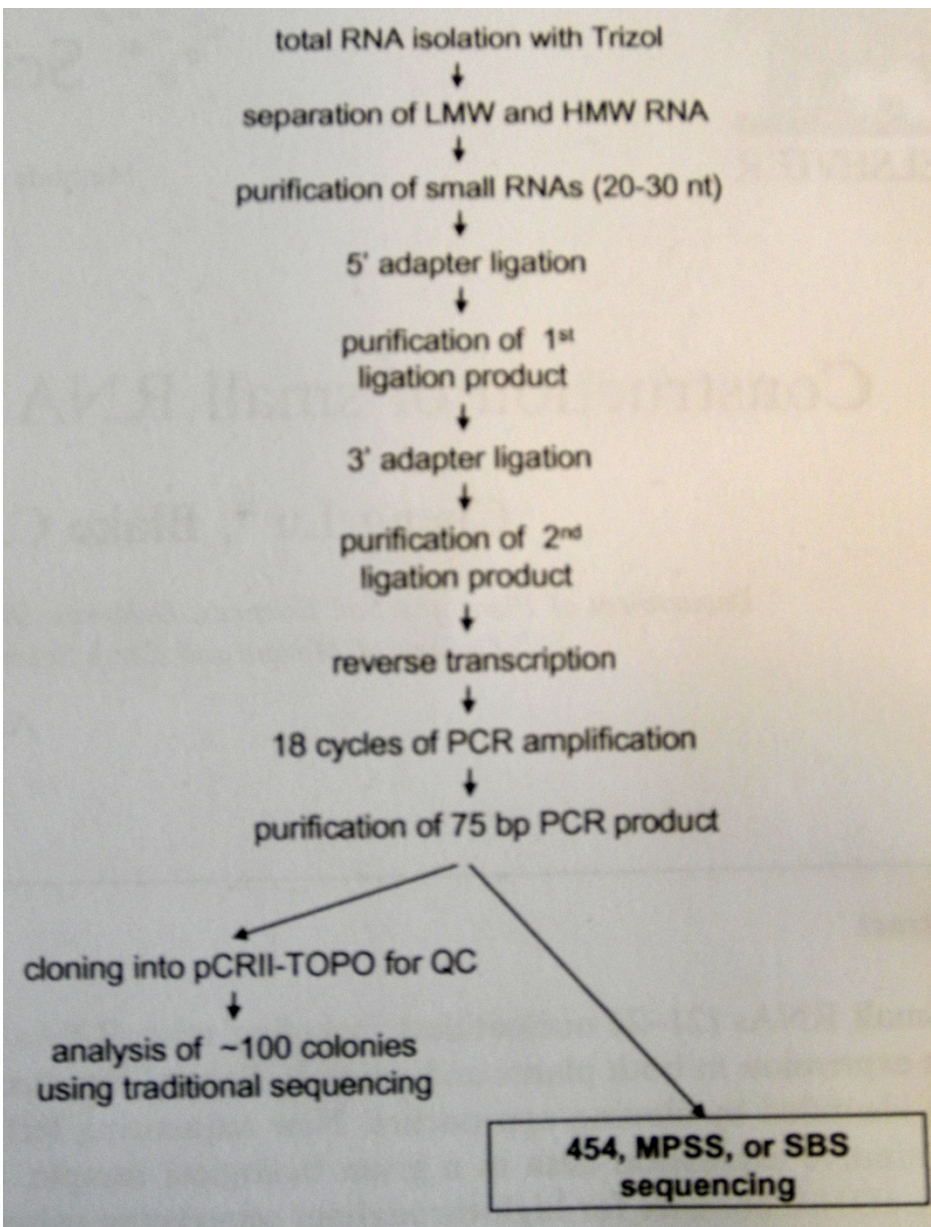

Fig. 2. Influence of RNA integrity on miRNA gene expression.

(A), miR-141, miR-155, miR-200c, and miR-210 in RNA samples from ccRCC cell line Caki-2. (B), miR-141, miR-155, miR-200c, and miR-210 in RNA samples from the renal tissue pool. (C), miR-96, miR-130b, miR-149, and miR-222 in RNA samples from PCA cell line LNCaP. (D), miR-96, miR-130b, miR-149, miR-205, and miR-222 in RNA samples from the prostate tissue pool. For further details, including regression line characteristics, 95% CIs of the slopes, and P values indicating significant deviations from 0, see Table 5 in the online Data Supplement.

Analýza microRNA

- Identifikace miRNA (deep sequencing, cloning a Northern blot)
- Real-Time PCR
- Microarrays



**Konstrukce cDNA knihovny
malých RNA**

Cloning nebo deep sequencing

Validace pomocí Northern blot

Real-Time PCR

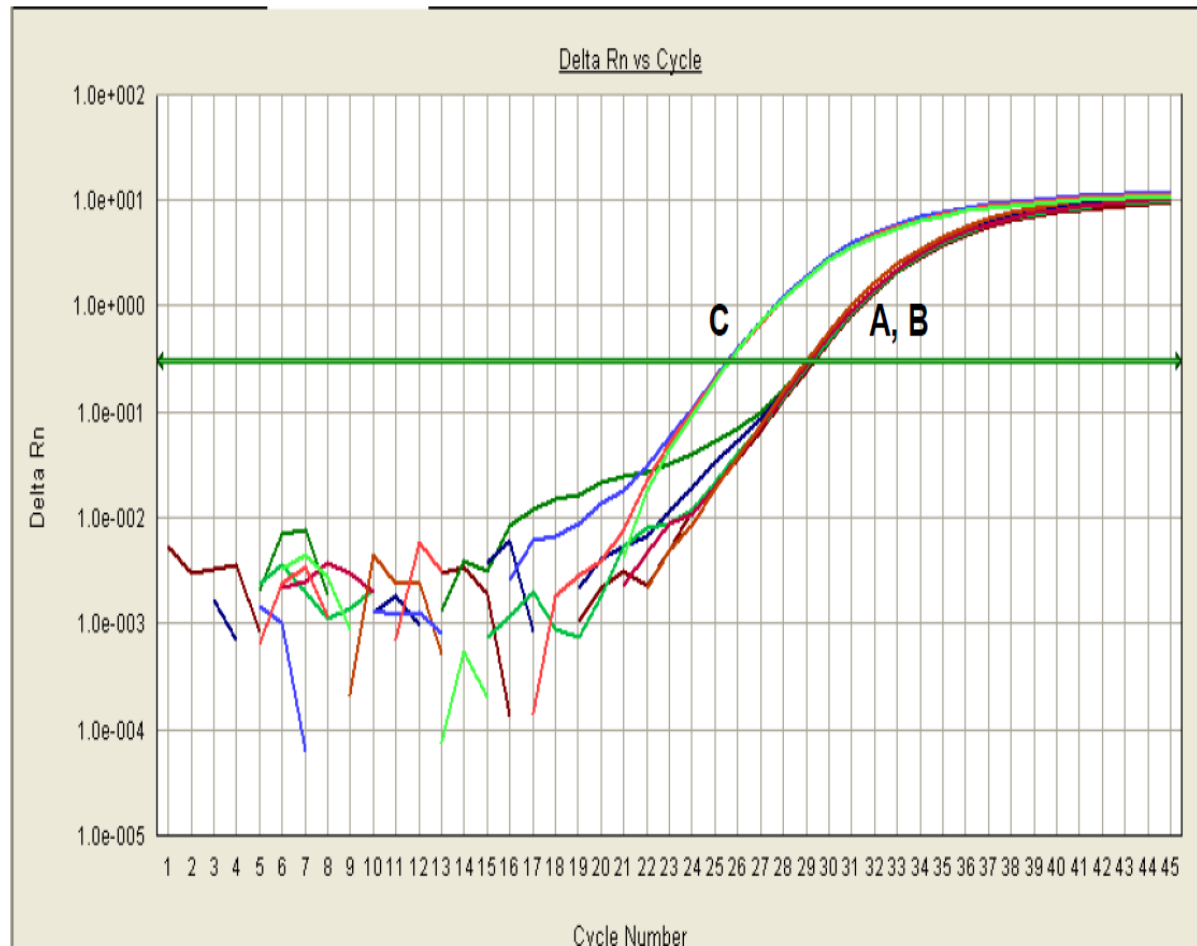
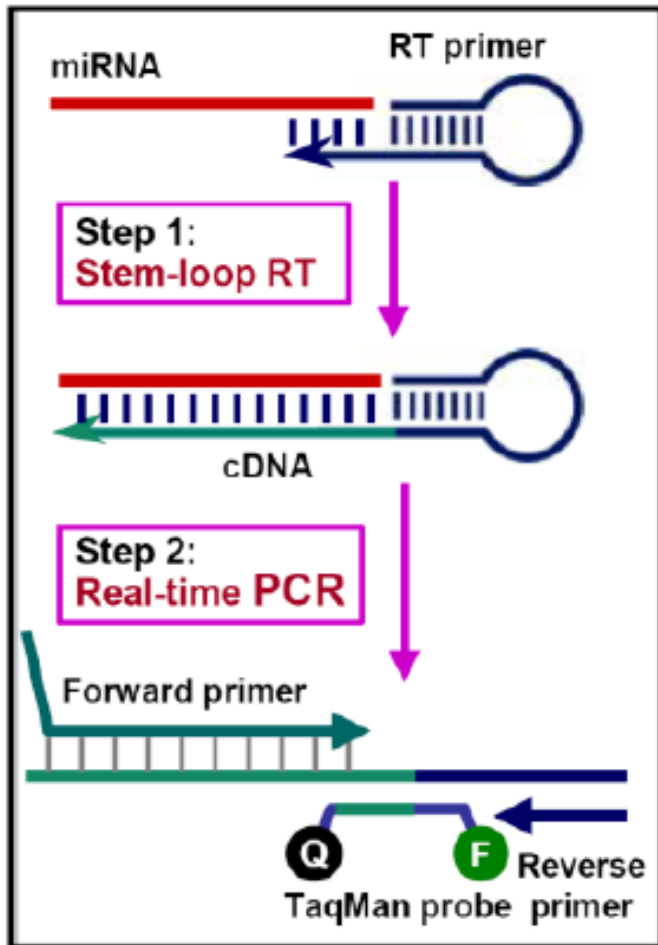
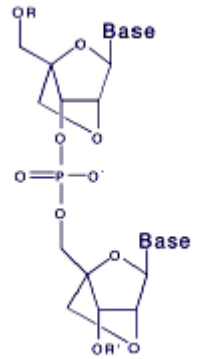

Chronická lymfatická leukémie a microRNA

- nejčastější leukémie dospělé populace !!!
- Projevy: krvácení, anémie, zvětšení uzlin a sleziny, infekce, hubnutí
- nádorovými buňkami jsou B lymfocyty (hromadí se v periferní krvi)
- prognóza onemocnění velmi variabilní (měsíce vs. desítky let)
- patogeneze není prakticky známa

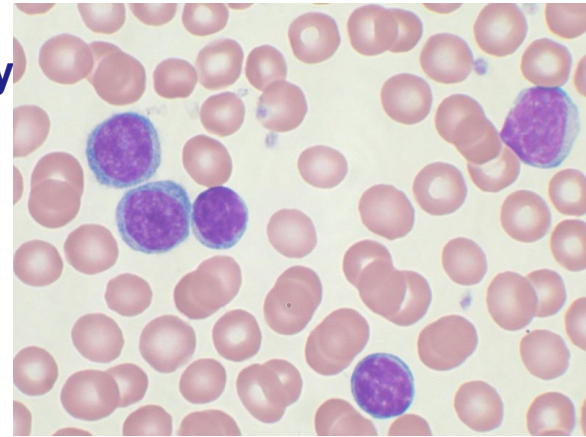

Value	Stage	Risk	Median Survival
Lymphocytosis (wbc > 15,000/mm ³)	0	Low	12.5 years
Lymphocytosis + nodal involvement	I	Int	8.5-9 years
Lymphocytosis + organomegaly	II		5-6 years
Anemia	III	High	9 months
Thrombocytopenia	IV		9 months

CLL a microRNA

❑ 13q14 lokus je často deletován u CLL a *miR-15a-16-1* leží v této oblasti. (Calin et al., 2002)

❑ *miR-15* a *miR-16* reguluje Bcl2. (Cimmino et al., 2005; Calin et al., 2008)

❑ Exprese microRNA rozlišuje mezi jednotlivými subtypy CLL : nemutované IgVH a mutované IgVH. (Calin et al., 2005; Marton et al., 2008; Zanette et al., 2007; Fulci et al., 2007)

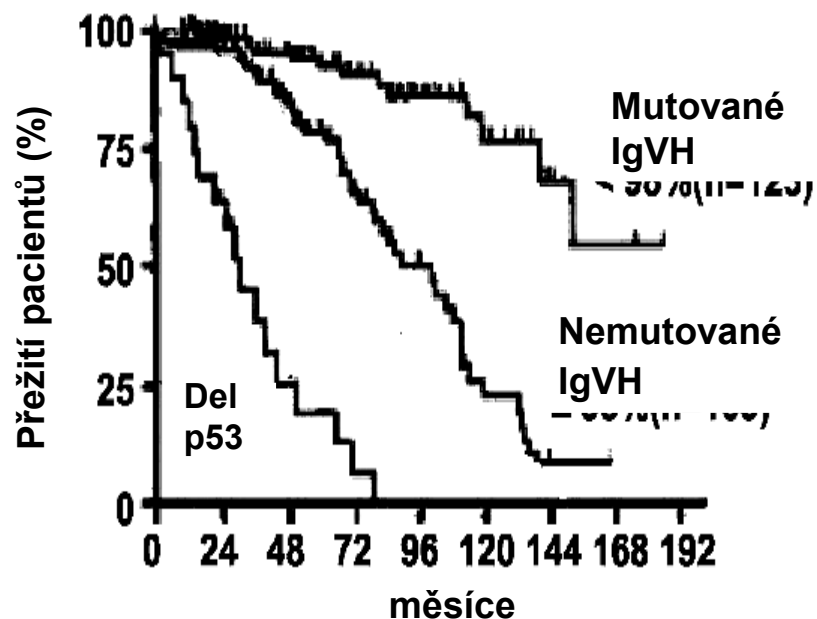

Stilgenbauer a Dohner, 2005, upraveno

p53 abnormalities => very aggressive CLL

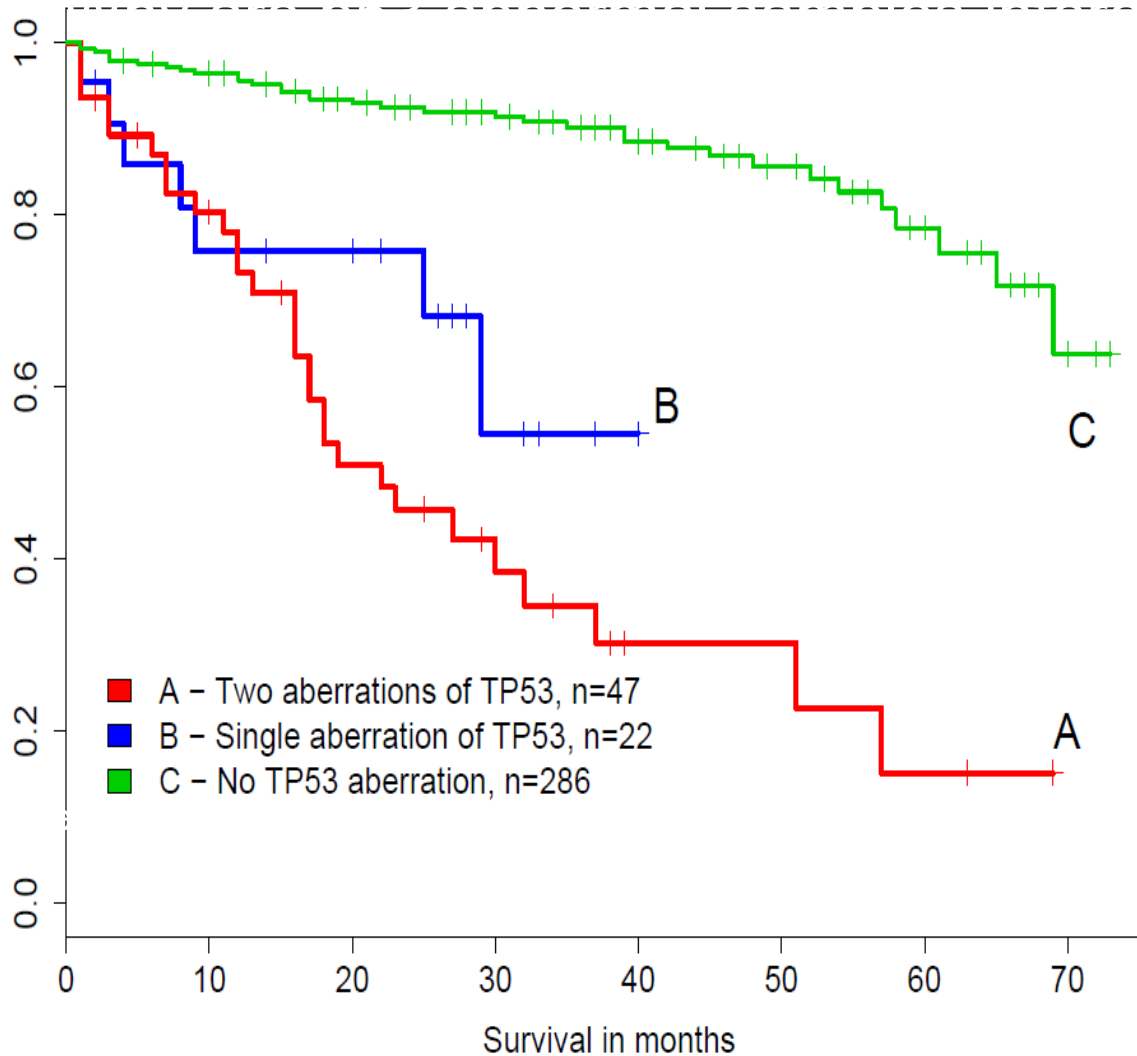

PŘEHLED METOD:

30 PACIENTŮ (♂/♀: 0,9; medián 63 let)
del/mut TP53 n=12 wt TP53 n=18

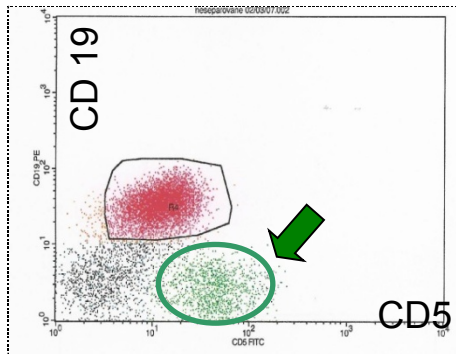

SEPARACE

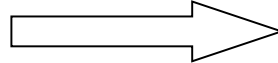

RosetteSep

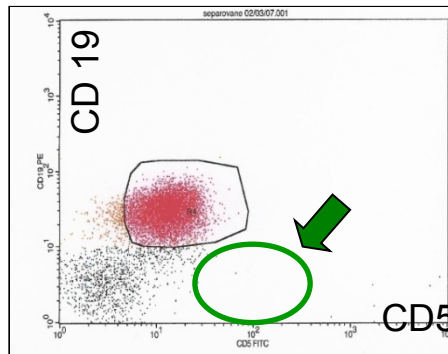

**PO SEPARACI
(PODÍL $\geq 95\%$
CLL
buněk)**

Real-Time PCR (TagMan ABI)
35 microRNA bylo vybráno
pro další studování

Pacienti s funkčním p53 mají ~ 10 násobně vyšší expresi *miR-34a* (p=0,000001)

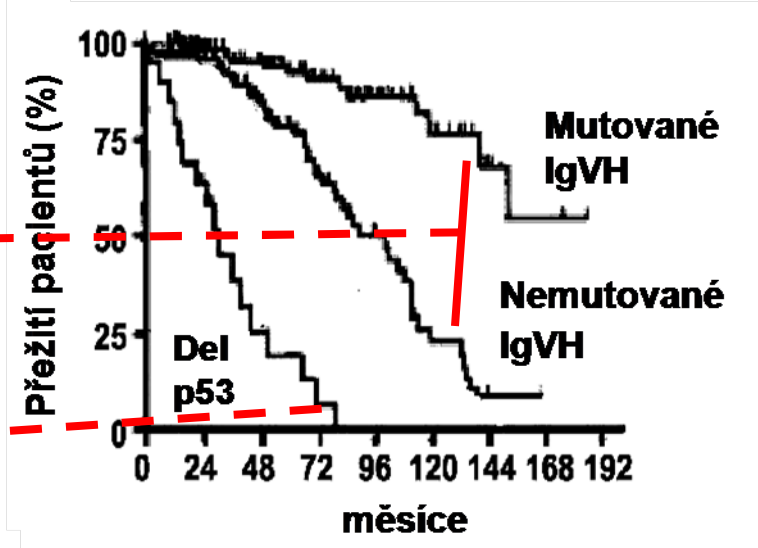
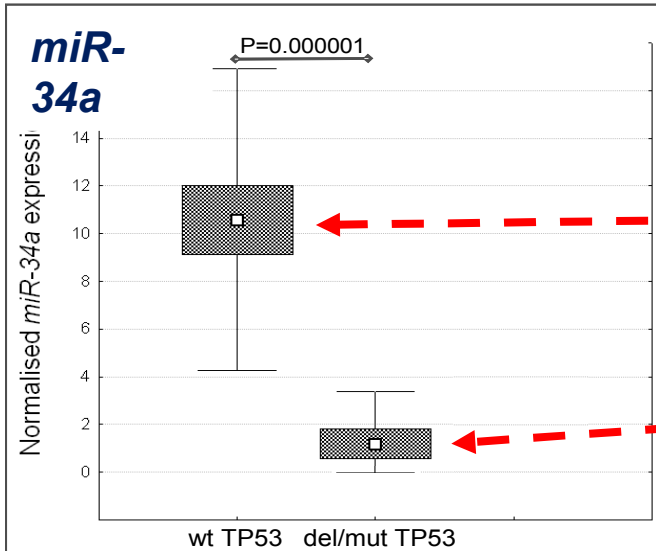

Normalised miRNA 34a expression

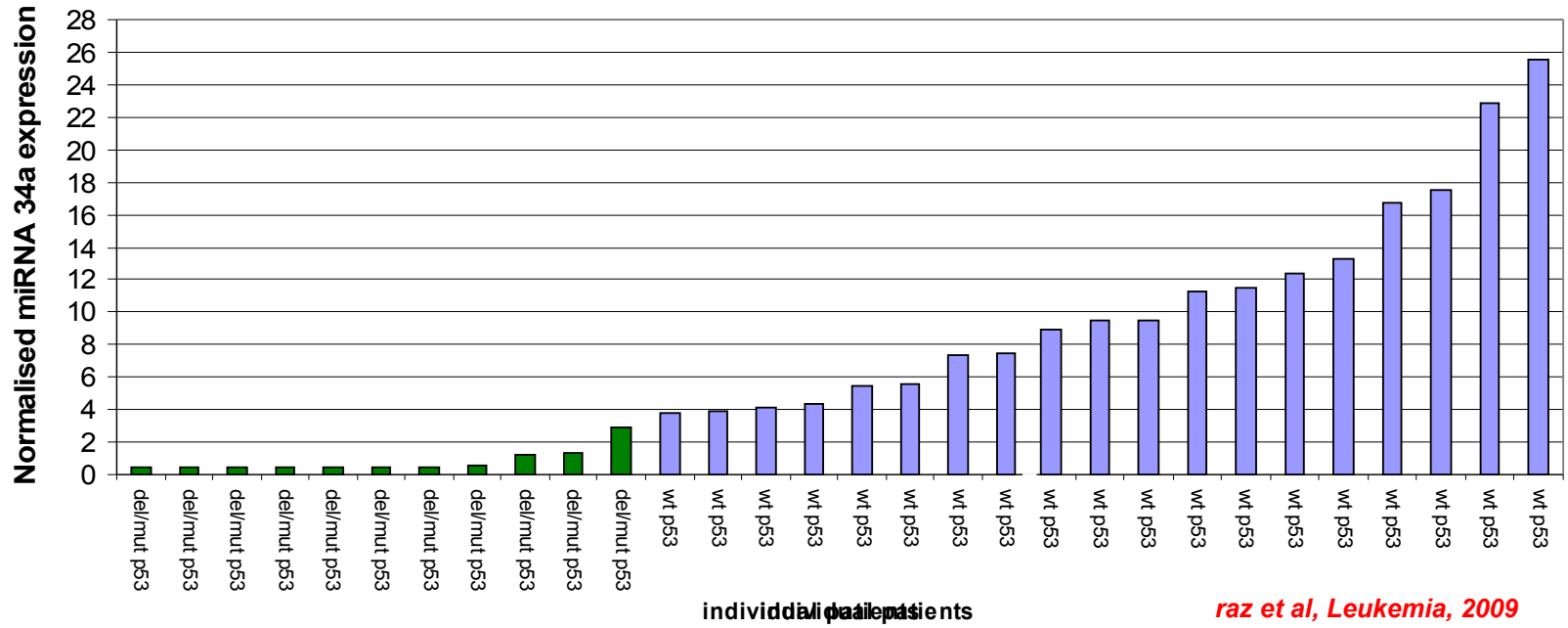

raz et al, Leukemia, 2009

miR-34a a regulace apoptózy

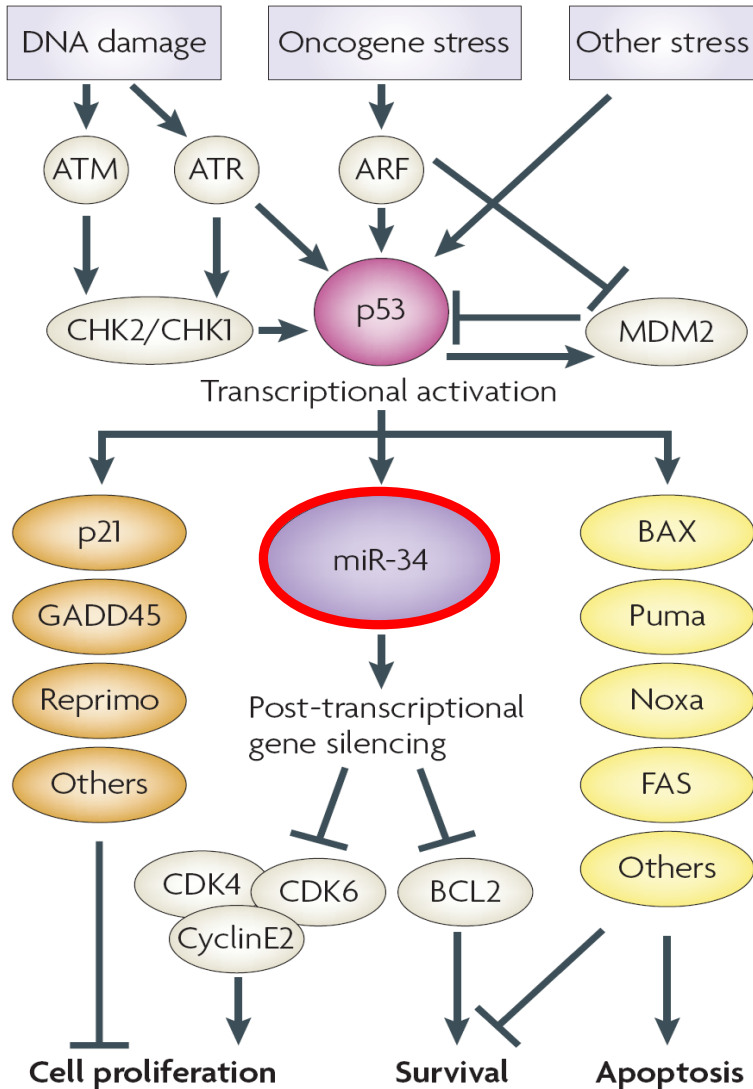

❑ *He et al., NATURE 2007:*
miR-34a je transkripčně aktivovaná proteinem p53 (studium buněčných linií)

❑ *Bommer et al., CURR. BIOL. 2007:*
miR-34a ovlivňuje BCL2 (studium buněčných linií)

❑ miR-34a je abnormálně exprimována u CLL pacientů s abnormalitou p53 (**Mraz et al., 2009;** **Mraz et al., 2009**)

❑ první potvrzení významu miR-34a přímo in vivo u pacientů

❑ je známa úloha BCL2 v patogenezi CLL, možný význam deregulace miR-34a

miR-29c

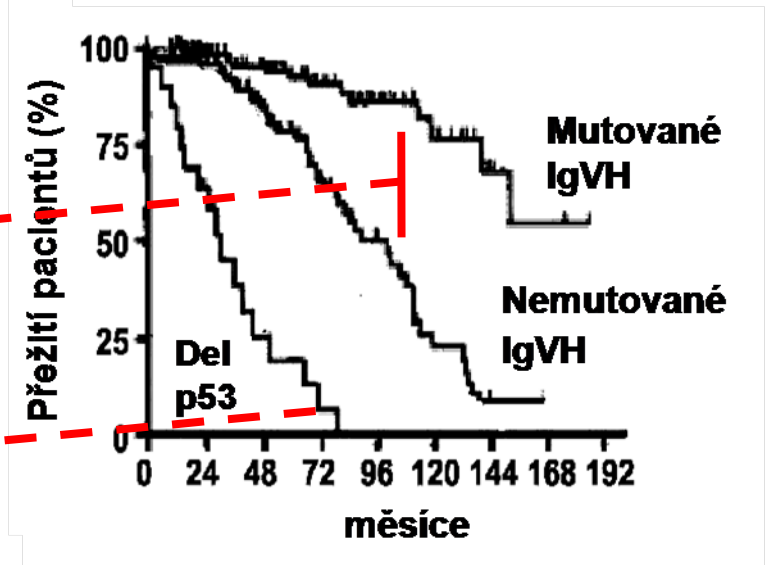
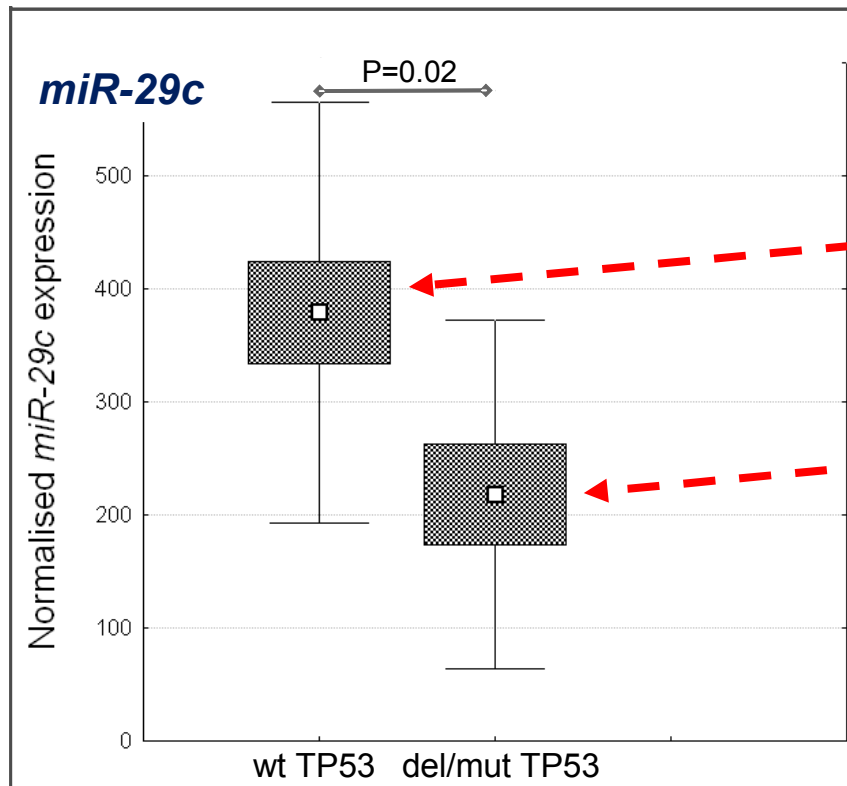

Stilgenbauer a Dohner, 2005, upraveno

- ❑ miR-29c reguluje expresi Tcl1 a Mcl1
- ❑ Tcl1 a Mcl1 proto-onkogeny jsou známy z myších modelů vzniku CLL (*Johnson et al. 2006; Zhou et al. 2001*)



raz et al, Leukemia, 2009

raz et al., Leuk Lymphoma, 2009

miR-17-5p

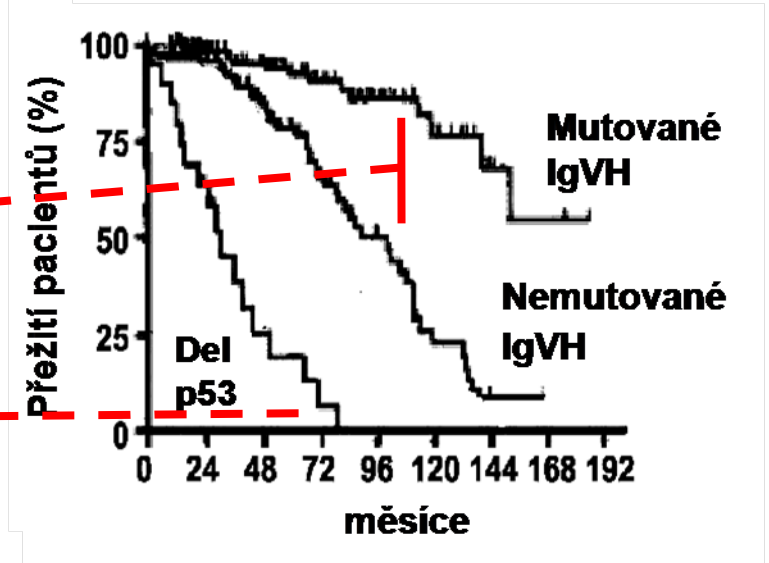
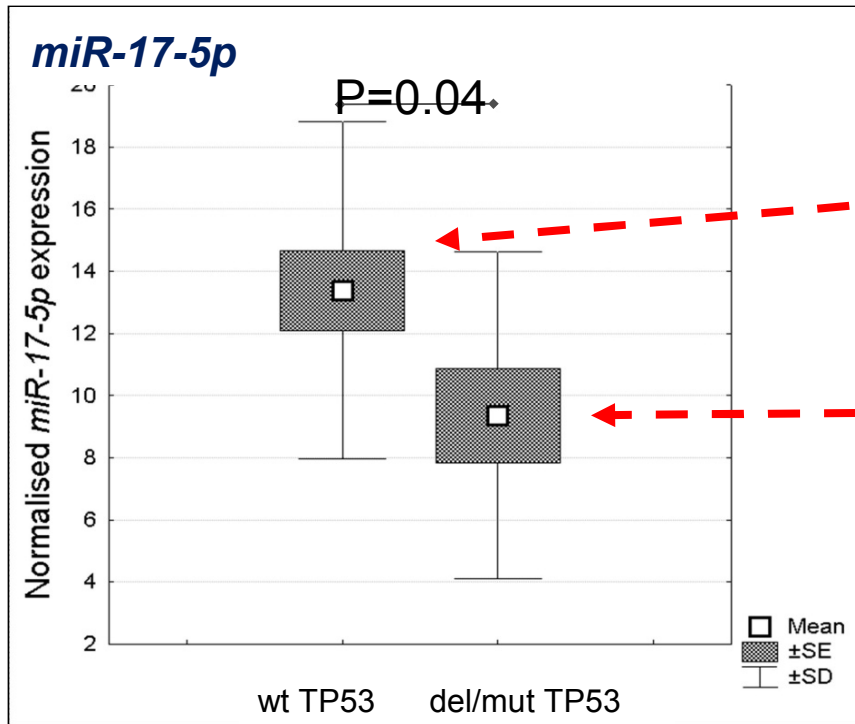

Stilgenbauer a Dohner, 2005, upraveno

- **Expres miR-17-5p je řízena proteinem c-myc**
- **miR-17-5p reguluje expresi E2F1, p21 a Cyclinu D1 (O'Donnell et al. 2005; Fontana et al. 2008)**

raz et al, *Leukemia*, 2009

raz et al., *Leuk Lymphoma*, 2009

Absolute quantification

miR-34a is aberrantly expressed in p53 abnormal samples

(Mráz et al., 2009; Mráz et al., 2009; Zenz et al., 2009; Asslaber et al., 2010)

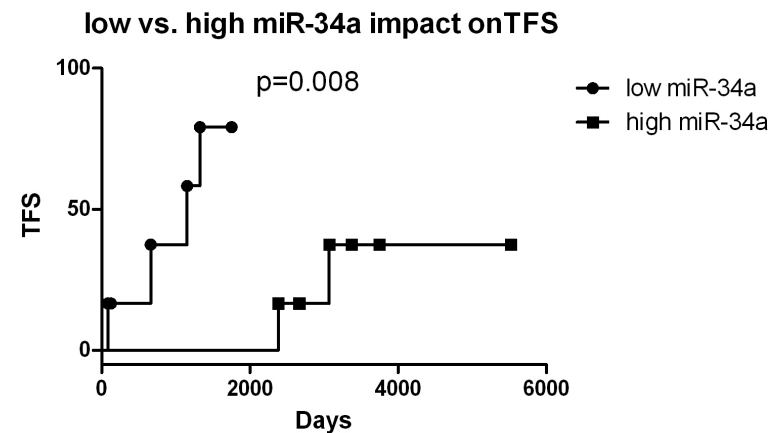
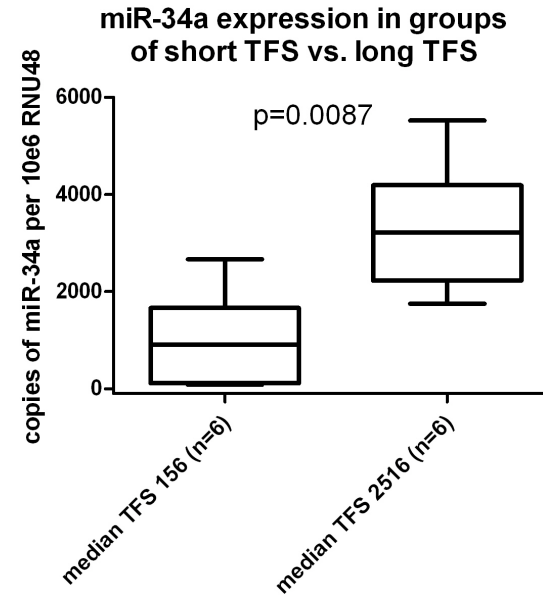
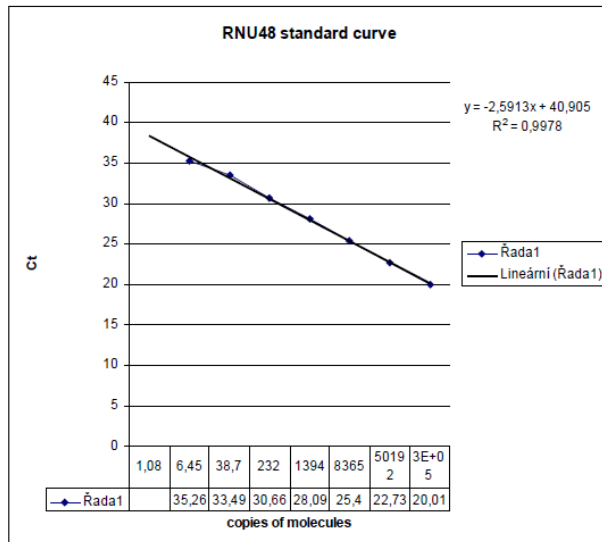
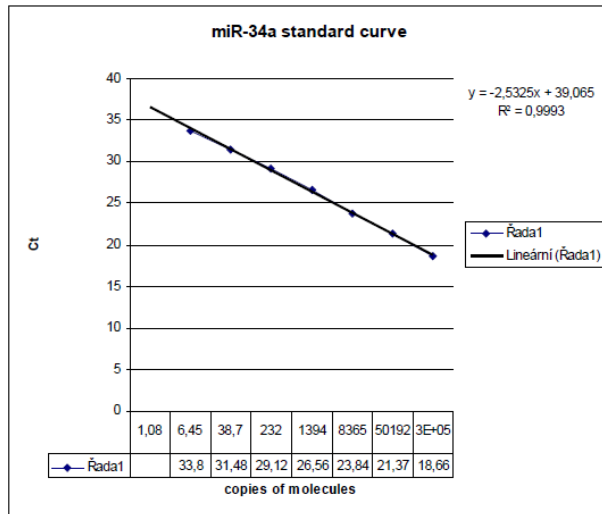

SHRNUTÍ VÝSLEDKŮ

- *miR-34a*, *miR-29c*, *miR-17-5p* jsou sniženě exprimovány u pacientů s agresivním CLL.
- Jedná se o první komplexní definování expresního profilu miRNA u pacientů s CLL a delecí/mutací *p53* genu.
- Rozdíly v expresi *miR-34a*, *miR-29c*, *miR-17-5p* mohou být významné v patogenezi/progresi agresivních subtypů CLL.

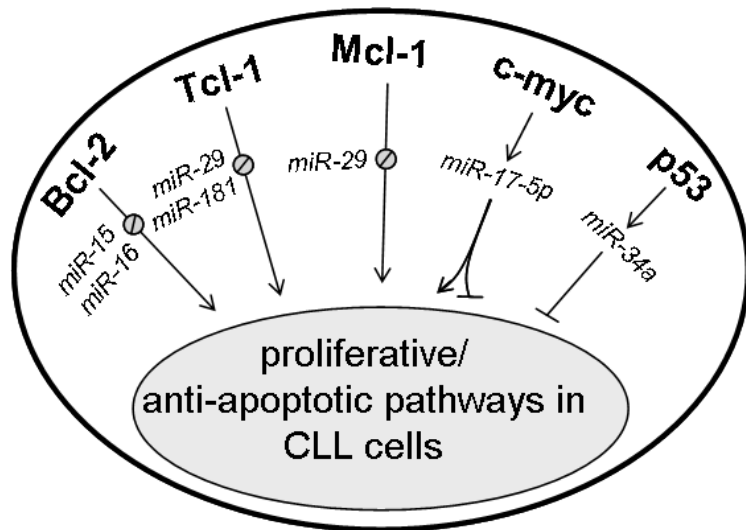

Mraz et al., Leukemia 2009
Mraz et al., Leukemia&Lymphoma, 2009
Mraz et al., BBRC, 2009

Je to k něčemu dobré i v medicíně?

Tab. 1
 Expresce microRNA u pacientů s nepříznivými prognostickými markery (nemutované IgVH a delece/mutace p53)

(dle Calin, 2005; Mraz, 2009b)

MicroRNA	Chromozomální oblast	Expresce miRNA u CLL vzorků s:	
		nemutovaným IgVH (ZAP70+) vs. mutovaným IgVH (ZAP70-)	deleci/mutaci p53 (bez ohledu na IgVH) vs. wild-type p53 (bez ohledu na IgVH)
miR-15a	13q14	VYSOKÁ	NEZMĚNĚNA
miR-16-1	13q14	VYSOKÁ	NEZMĚNĚNA
miR-16-2	3q26	VYSOKÁ	NEZMĚNĚNA
miR-23b	9q22	VYSOKÁ	NEZMĚNĚNA
miR-24-1	9q22	VYSOKÁ	NEZMĚNĚNA
miR-29a-2	7q32	NÍZKÁ	NEZMĚNĚNA
miR-29b-2	1q32	NÍZKÁ	NEZMĚNĚNA

Expression microarrays pro microRNAs:

- velmi malé molekuly – 22nt – specifikum izolace, specifické značení i design sond
- malé zastoupení ve vzorku – separace microRNA
- v lidském genomu cca 1000 genů – menší počet sond na čipu
- některé mají velmi podobnou sekvenci – rozdíl 1nt
- pre-miR, pri-miR, mature-miR
- málo se ví o jejich funkcích – obtížná interpretace výsledků
- zatím málo zkušeností a standardizace

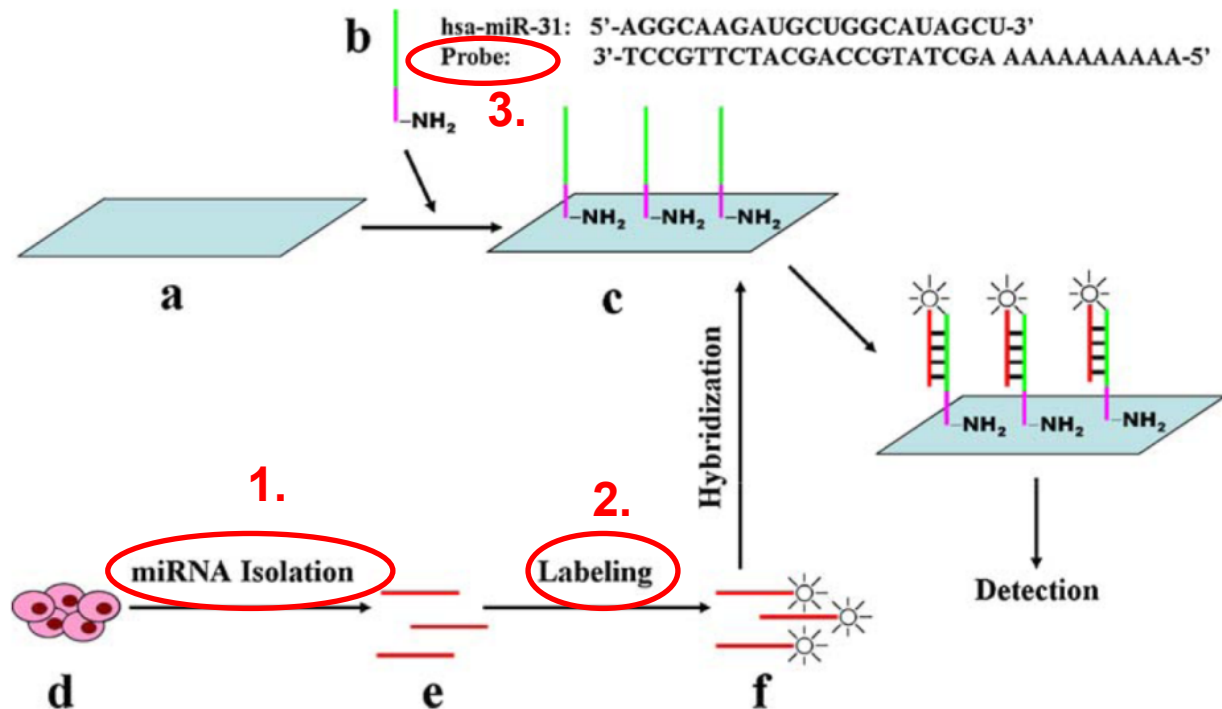

3/ Labeling – značení:

- ❑ Není možný labeling pomocí značených polyT při reverzní transkripci
- ❑ Přímé značení (direct labeling) – většinou nějaká fluorescenční barva
- ❑ Nepřímé značení (indirect labeling) – probíhá krok reverzní transkripce/PCR

Přímé značení:

Jednoduché, rychlé a „čím méně kroků tím méně vnesených chyb a variability“

1/ Značení guaninu v microRNA

Fluochromem vážícím se na guanin jsou označeny miRNA (Ulysis Alexa Flour 546/647)

Všechny lidské miRNA obsahují guanin, ale v různém množství

Nemožnost usuzovat na vzájemnou expresi různých miRNA (různý obsah guaninu)

(Babak et al., 2004)

2/ Značení pomocí Poly (A) polymerázy

Můžu se rozhodnout jak dlouhý bude poly(A)

a tím ovlivnit sílu signálu

(Shingara et al., 2005)

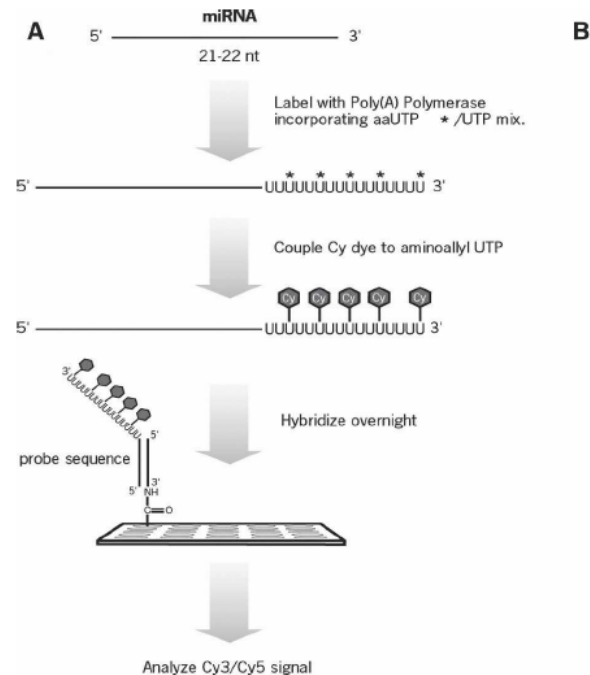

3/ značení chemickou metodou

3'OH skupina je oxidována na dialdehyd

Následuje reakce s Biotin-X-hydraxidem → Biotinilovaná miRNA

Vazba fluoresceční molekuly-quantum dot

(Liang et al., 2005)

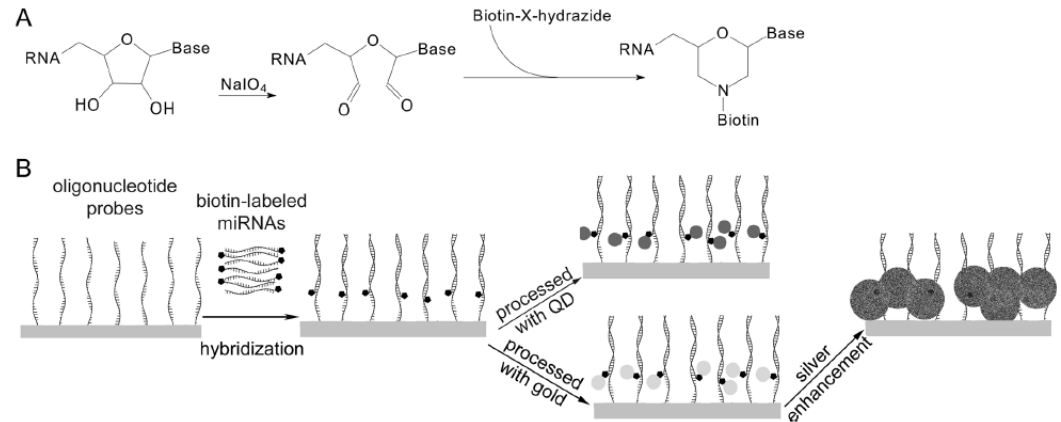

Figure 1. Schematic principles of the miRNA profiling microarray. (A) Principle of labeling miRNA at the 3' terminus with biotin. (B) Principle of the miRNA profiling microarray detected with QD or colorimetric method.

4/ značení pomocí T4 ligasy

Krátký značený oligonukleotid

je připojen T4 ligásou k 3'konci

Výhodou je přednostní vazba

na RNA o velikosti 18-30bp → total RNA

(Thomson et al., 2004; Castoldi et al., 2007)

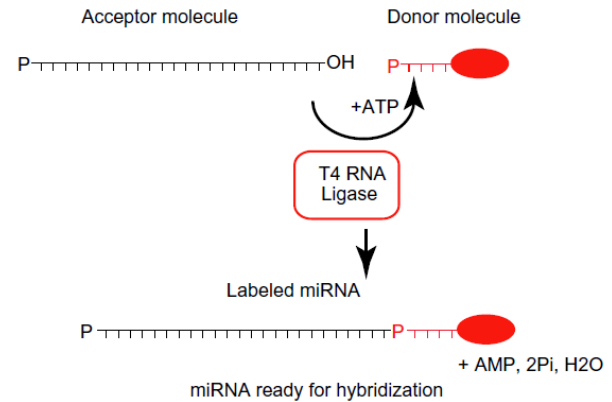

Fig. 2. Schematic representation of the miRNA labeling principle: a short Cy-dye labeled RNA-linker (donor molecule) is ligated to the single-stranded miRNA (acceptor molecule) by T4 RNA ligase in the presence of ATP.

Nepřímé značení:

Značen je produkt reverzní transkripce či RT-PCR

Výhody: cDNA je pak stabilní a lze uchovat, Pre-amplifikace a tím snadnější detekce méně exprimovaných miRNA

1/ značení reverzního transkriptu miRNA

Reverzní transkripce pomocí náhodných 8-merů značených 2 biotiny (3'-(N)8 – (A)12-biotin-(A)12-biotin-5' (Liu et al., 2004)

Reverzní transkripce pomocí náhodných neznačených 7-merů, následně označeny s pomocí terminální transferázy a biotin-dideoxy-UTP (Sun et al., 2004)

Nebezpečí chyb z nespecifické vazby primeru

2/ značení produktu RT-PCR

Výhoda: snadná pre-amplifikace

Dva adaptory

fluorescenčně-značený primer (k adaptoru)

(Miska et al., 2004)

Nevýhoda: antisense strand přítomen při hybridizaci

Rešením je různá délka sense a antisense ->PAGE

(Baskerville, 2005)

3/ značení in vitro transkriptu

Jeden z adaptorů je promotor T7 RNA polymerázy

(Barad et al. 2004)

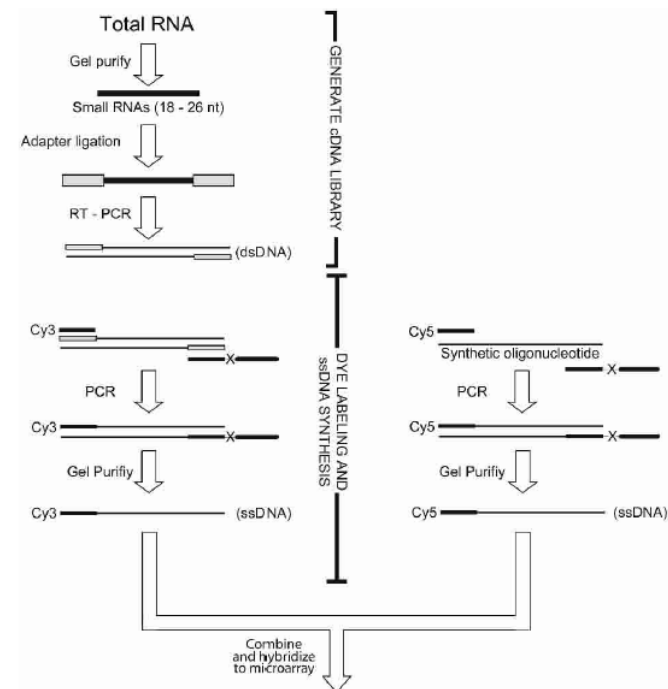

3/ Microarrays/ Próby: Problémy: krátké RNA, malé rozdíly v sekvenci, Tm

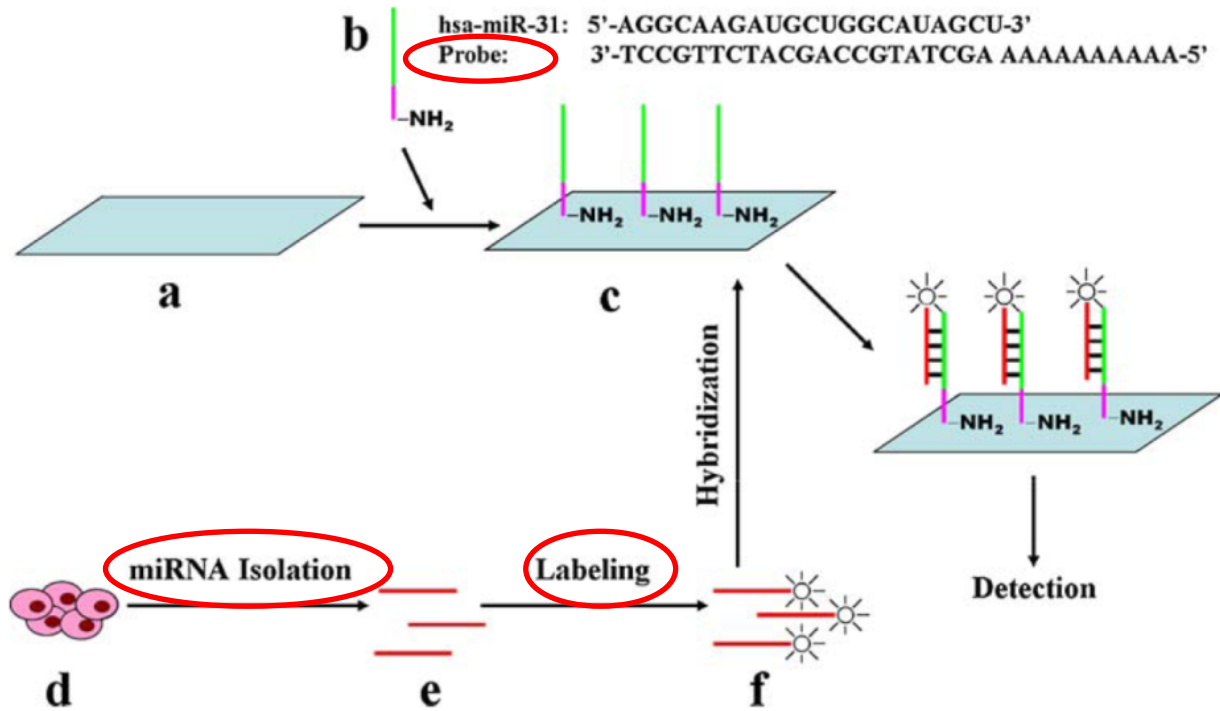

T_m – melting temperature určité próby

T – hybridizační teplota

$T_m < T$ nižší efektivita vazby miRNA

$T_m > T$ vyšší efektivita vazby miRNA

- Je třeba navrhnout próby tak, a by měly všechny podobnou T_m
- To se u „dlouhých“ mRNA řeší vhodným výběrem oblasti genu k němuž bude sonda komplementární nebo délkou sondy
- navíc některé miRNA jsou téměř sekvenčně totožné

```
let-7b : TGAGGTAGTAGGTTGTGTGTT : 22
let-7e : TGAGGTAGGAGGTTGTATAGT- : 21
let-7d : AGAGGTAGTAGGTTGCATAGT- : 21
let-7a : TGAGGTAGTAGGTTGTATAGTT : 22
let-7f : TGAGGTAGTAGATTGTATAGTT : 22
let-7i : TGAGGTAGTAGTTTGTGCT--- : 19
let-7g : TGAGGTAGTAGTTTGTACAGT- : 21
      tGAGGTAGtAG TTGt gt
```

ÚPRAVA DÉLKY PRÓBY

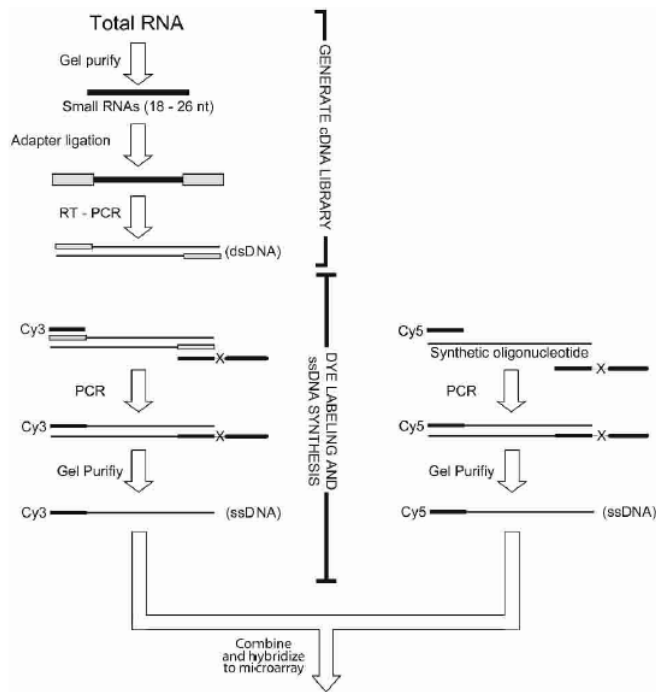

FIGURE 1. Microarray sample preparation and reference oligonucleotide synthesis. Small RNAs were fractionated on a polyacrylamide gel, and oligonucleotide primers were then ligated to the 5' and 3' ends of the small RNA library (Lau et al. 2001). A cDNA library was generated through reverse transcription, and the product was amplified using PCR. Using a pair of modified oligonucleotide primers in a second PCR, the sense strand of the library was fluorescently labeled and the antisense strand was selectively lengthened (Williams and Bartel 1995). The sense strand of the asymmetric duplex was purified away from the antisense strand in a denaturing gel, and this purified dye-labeled ssDNA sample was used for hybridization and detection on the array. At each feature, the signal from the miRNA sample was compared to that from a reference sample, which had been generated by amplifying and labeling synthetic oligonucleotides using the same strategy as for the miRNA sample.

Baskerville and Bartel, 2005

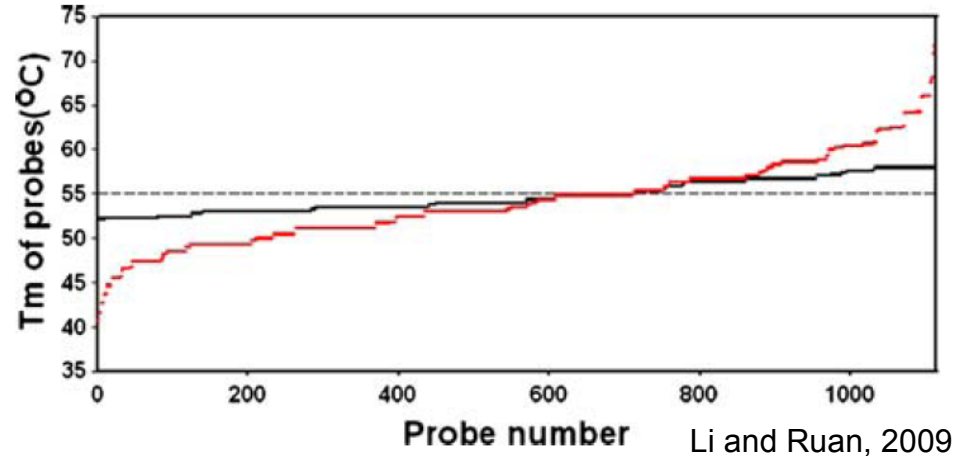
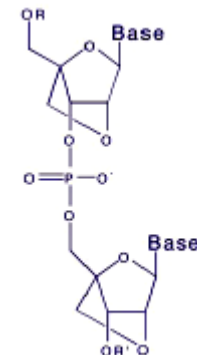

Fig. 2 T_m (melting temperature) distribution for microRNA probes for human, rat and mouse. *Red and black curves* represent the T_m distributions of the raw and normalized probes, respectively

ÚPRAVA SÍLY VAZBY NUKLEOTIDŮ

LNA próby (Locked Nucleic Acid)

ribózový kruh je „uzamčen“ methylenovým můstkem mezi atomy 2'-O a 4'-C



Použití LNA pro některé báze v próbě

SPECIFITA VAZBY: LNA próba

(Castoldi et al., 2006)

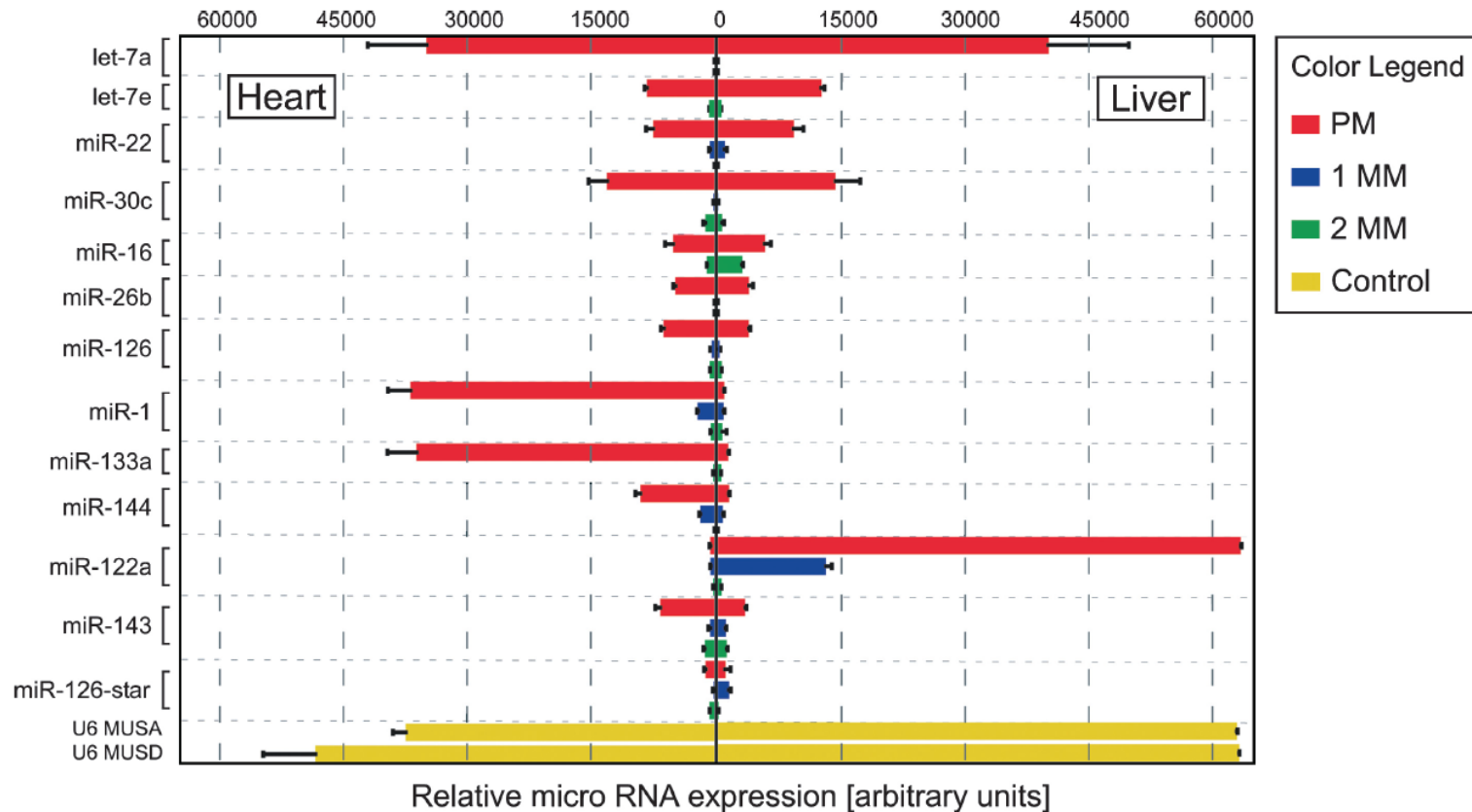

FIGURE 2. Accurate miRNA detection in murine heart and liver samples using T_m normalized LNA-modified capture probes. Detection of miRNA expression by PM (perfect match; 100% complementarity to the miRNA sequence), 1MM (single nucleotide mismatch at the central position of the nucleotide sequence of the mature miRNA), and 2MM (two nucleotide mismatches at the central position) LNA-modified captures probes. Data are presented as median intensity \pm SD (four replicas per miRNA capture probe; a representative experiment is shown).

SÍLA VAZBY: LNA vs DNA próba

T_m až 72 C
(Castoldi et al., 2006)

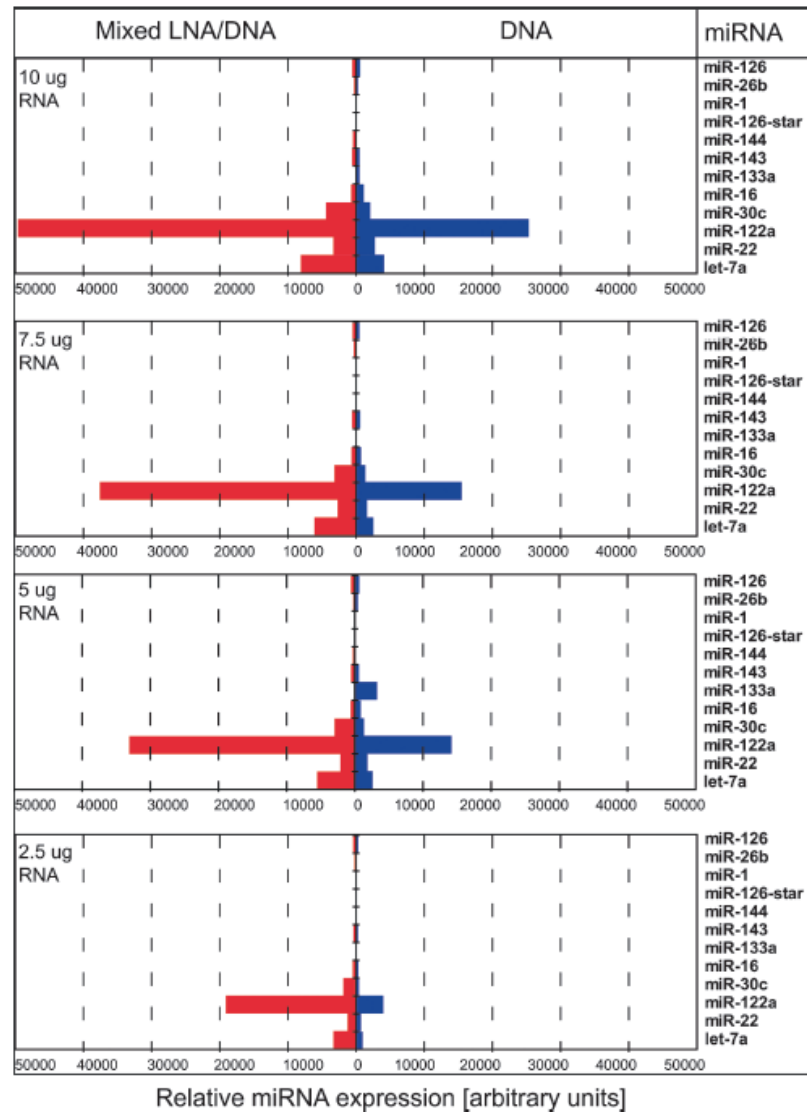

FIGURE 1. Mixed DNA/LNA capture probes display increased sensitivity for miRNA detection. miRNA expression was assessed in murine liver using a test set of LNA-modified (*left*) or unmodified DNA oligonucleotide capture probes (*right*). Decreasing amounts of total RNA were used as input material for miRNA analysis. Data are presented as median intensity (four replicas per miRNA capture probe; a representative experiment is shown).

DÁ TO HODNĚ PRÁCE

miRCURY LNA Array, Exiqon : 3 dny

Protocol overview

miRCURY™ LNA microRNA Power Labeling Kit

CIP treatment

Mix: RNA sample
Spike-In miRNA kit



Labeling reaction

Mix: CIP'ed RNA sample
Labeling buffer
Hy3™ or Hy5™
DMSO
Enzyme



miRCURY™ LNA microRNA Array Kit

Mix samples

Mix: Hy3™ labeled sample
Hy5™ labeled sample
Hybridization buffer
Denature sample



Hybridize

Hybridize at 56°C for 16 hours



Stringency wash

Wash 2 min. in buffer A at 56°C
Wash 2 min. in buffer B at 23°C
Wash 2 min. in buffer C at 23°C
Dry slides



Image acquisition

Scan slides (recommended scan at 5µm)
Download relevant GAL files from
www.exiqon.com

Co se nemusí podařit:

Nekvalitní RNA

Nepodaří se značení

Nepodaří se hybridizace

Nepodaří se promývání

Technická variabilita čipů je větší než ta biologická

Nepodaří se validace dat pomocí RT-PCR, atd

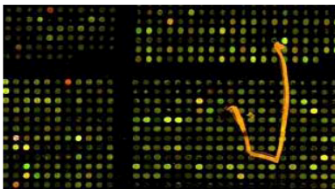

Fiber or scratch?

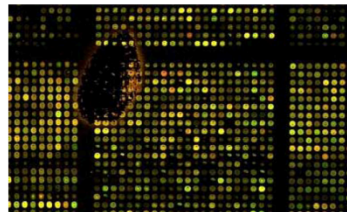

Bubble

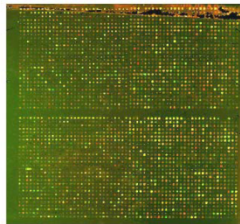

Edge effect

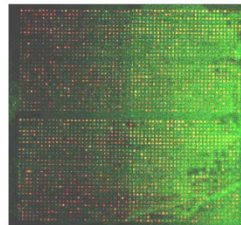

Background haze

Práce s miRNA čipy je velmi obtížná. Všeobecně nižší míra standardizace. Obtížná interpretace získaných dat z pohledu biologického smyslu např. deregulace několika miRNA (nádor vs. zdravá tkáň apod.)

microRNA exprese je schopná rozlišit původ nádoru

a

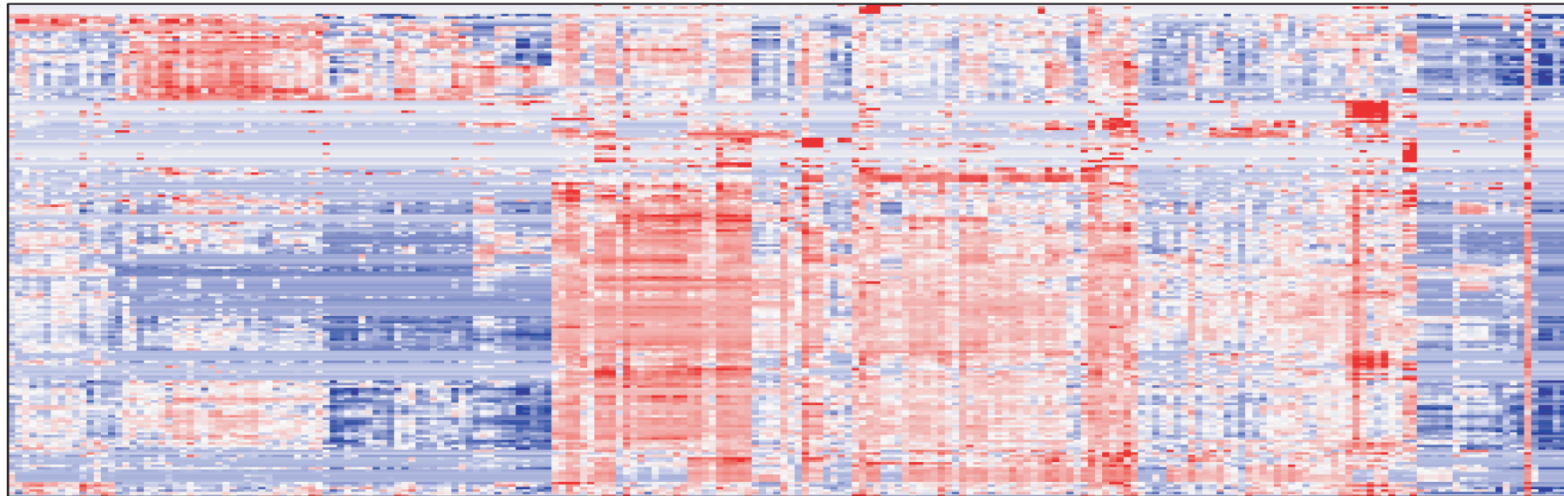
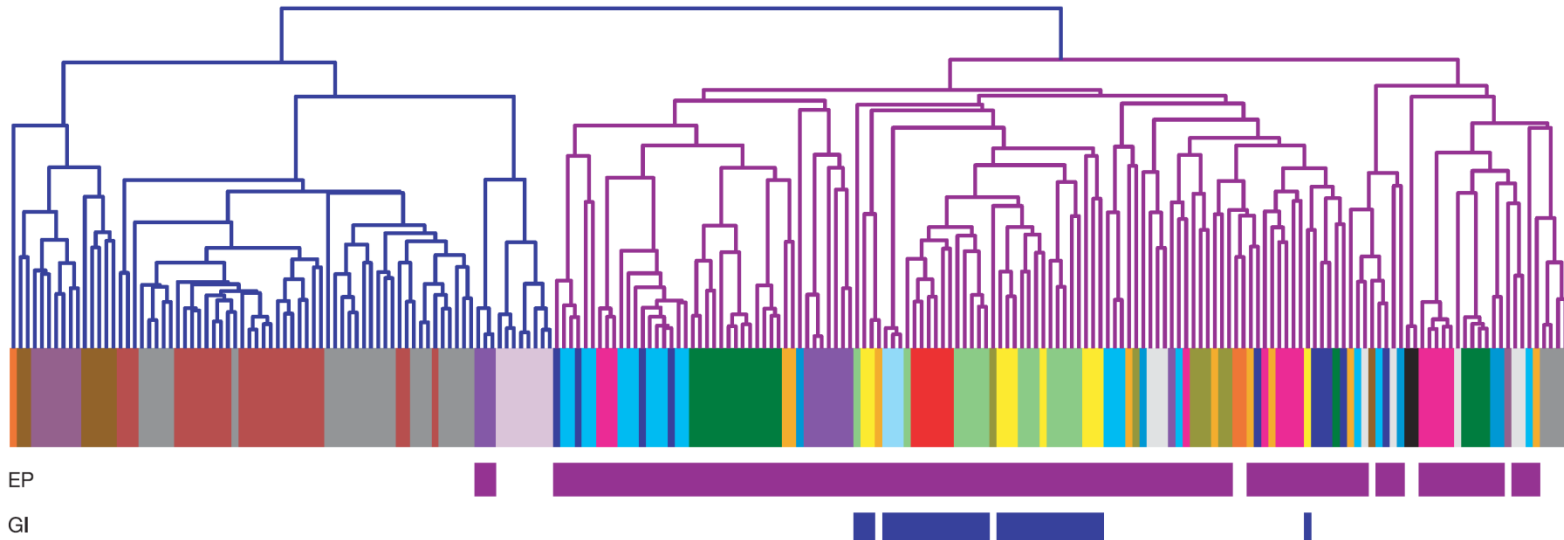

Chronická lymfatická leukémie a microRNA

- nejčastější leukémie dospělé populace !!!
- Projevy: krvácení, anémie, zvětšení uzlin a sleziny, infekce, hubnutí
- nádorovými buňkami jsou B lymfocyty (hromadí se v periferní krvi)
- prognóza onemocnění velmi variabilní (měsíce vs. desítky let)
- patogeneze není prakticky známa

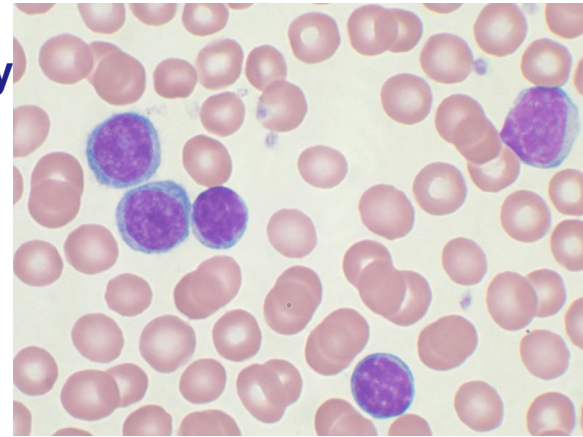

Value	Stage	Risk	Median Survival
Lymphocytosis (wbc > 15,000/mm ³)	0	Low	12.5 years
Lymphocytosis + nodal involvement	I	Int	8.5-9 years
Lymphocytosis + organomegaly	II		5-6 years
Anemia	III	High	9 months
Thrombocytopenia	IV		9 months

CLL Prognóza

Nepříznivá:

- High Rai / Binet staging
- Lymphocyte doubling time < 6 mo
 - Montserrat Br J Hematol 62:567, 1986
- B2M elevated
 - Hallek M Leuk Lymph 22:439, 1996
- sCD23 elevated
- Specific Genetic abnormalities
 - + 12
 - 11q- / del 11q22-23 (ATM)
 - 17p- / del 17p13 (P53)
- CD38 positive
- Unmutated Ig Vh gene
 - Hamblin Blood 94:1848, 1999
- ZAP-70 positive
 - Crespo NEJM 348:1764, 2003

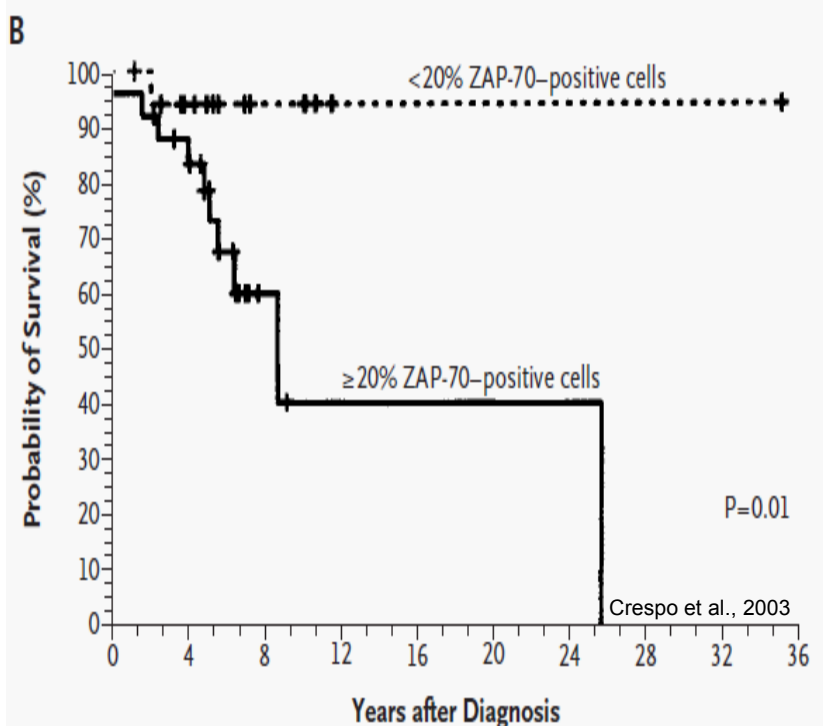
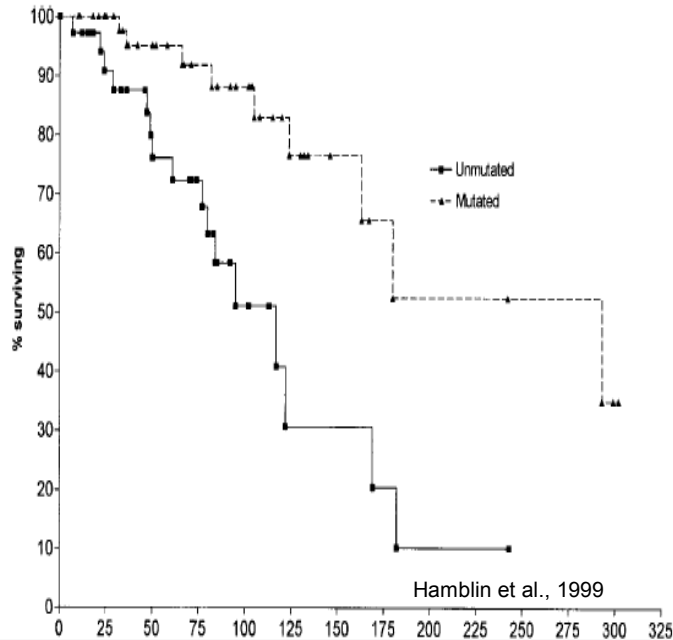

A MicroRNA Signature Associated with Prognosis and Progression in Chronic Lymphocytic Leukemia

George Adrian Calin, M.D., Ph.D., Manuela Ferracin, Ph.D.,
Amelia Cimmino, M.D., Ph.D., Gianpiero Di Leva, Ph.D.,
Masayoshi Shimizu, B.S., Sylwia E. Wojcik, M.Sc., Marilena V. Iorio, Ph.D.,
Rosa Visone, Ph.D., Nurettin Ilfer Sever, Ph.D., Muller Fabbri, M.D.,
Rodolfo Iuliano, Ph.D., Tiziana Palumbo, Ph.D., Flavia Pichiorri, Ph.D.,
Claudia Roldo, M.D., Ramiro Garzon, M.D., Cinzia Sevignani, Ph.D.,
Laura Rassenti, Ph.D., Hansjuerg Alder, Ph.D., Stefano Volinia, Ph.D.,
Chang-gong Liu, Ph.D., Thomas J. Kipps, M.D., Ph.D.,
Massimo Negrini, Ph.D., and Carlo M. Croce, M.D.

Design

- n=94 CLL pt. samples for initial dataset
- Known clinical outcome data and ZAP-70 and IgVh mutation status (retrospective)
 - Zap-70 - >20% or < 20%
 - IgVh status – mutated or unmutated based on sequencing (>98% homology cutoff)
- microRNA microarray analysis of 245 miRNAs (a subset of known miRNA)

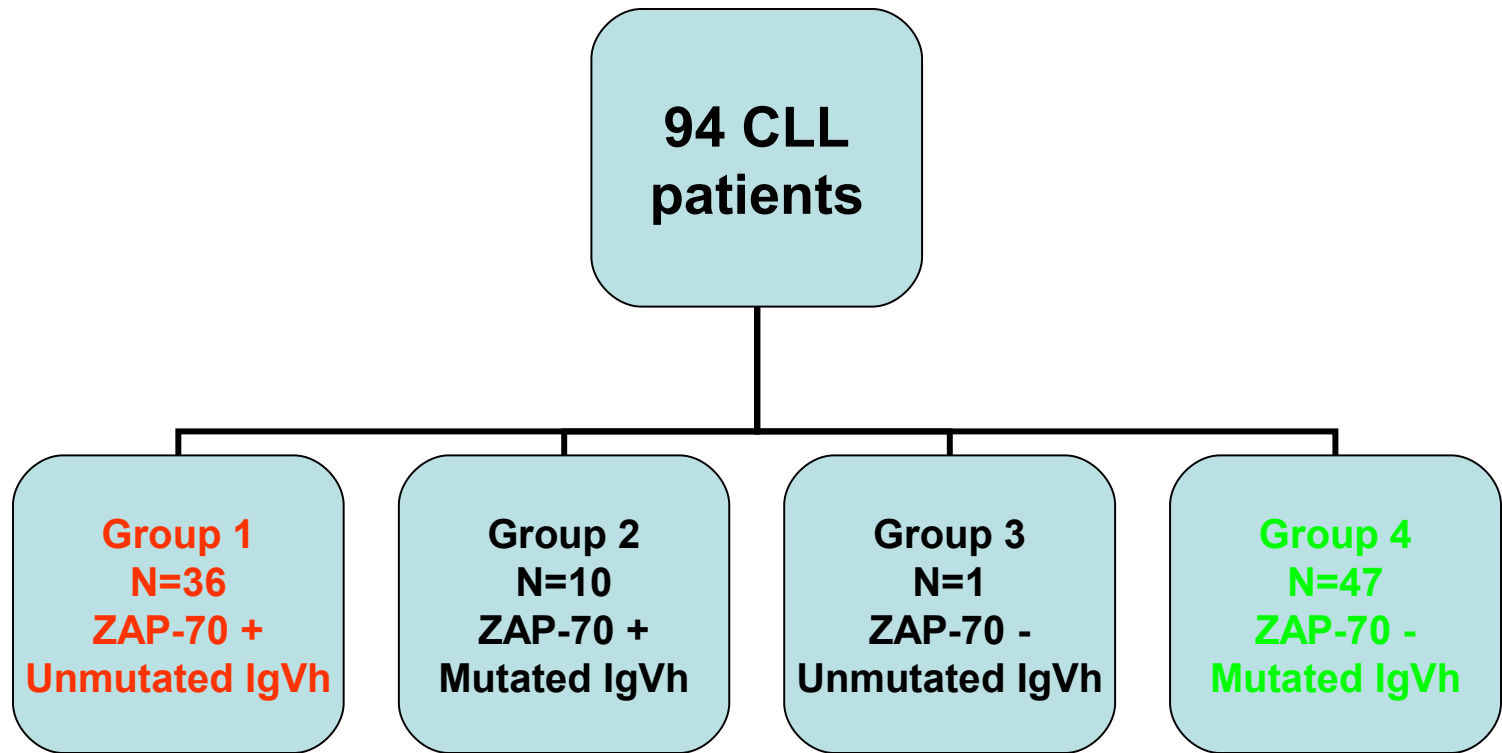

miRNA micro-array
(supervised)

13 miRNA signature (all mature):
discriminates group 1 from group 4 ($p < 0.01$)

Table 2. MicroRNA Signature Associated with Prognostic Factors (ZAP-70 Expression and *IgV_H* Mutations) and Disease Progression in Patients with CLL.*

Signature Component	MicroRNA Component	Chromosomal Location	P Value	Level of Expression in Group 1†	Putative Targets‡	Comment§
1	<i>miR-15a</i>	13q14.3	0.02	High	<i>BCL2, CNOT6L, USP15, PAFAH1B1, ESRRG</i>	Cluster <i>miR-15a–miR-16-1</i> Deleted in CLL and prostate carcinoma ¹⁰
2	<i>miR-195</i>	17p13	0.02	High	<i>BCL2, CNOT6L, USP15, PAFAH1B1, ESRRG</i>	Deleted in hepatocellular carcinoma
3	<i>miR-221</i>	Xp11.3	0.01	High	<i>HECTD2, CDKN1B, NOVA1, ZFPM2, PHF2</i>	Cluster <i>miR-221–miR-222</i>
4	<i>miR-23b</i>	9q22.1	0.009	High	<i>FNBP1L, WTAP, PDE4B, SATB1, SEMA6D</i>	Cluster <i>miR-24-1–miR-23b</i> FRA 9D; deleted in urothelial carcinoma ¹³
5	<i>miR-155</i>	21q21	0.009	High	<i>ZNF537, PICALM, RREB1, BDNF, QKI</i>	Amplified in a child with Burkitt's lymphoma ¹⁶
6	<i>miR-223</i>	Xq12–13.3	0.007	Low	<i>PTBP2, SYNCRIP, WTAP, FBXW7, QKI</i>	Expression normally restricted to myeloid lineage ²³
7	<i>miR-29a-2</i>	7q32	0.004	Low	NA	Cluster <i>miR-29a-2–miR-29b-1</i> FRA7H; deleted in prostate carcinoma ¹³
8	<i>miR-24-1</i>	9q22.1	0.003	High	<i>TOP1, FLJ45187, RSBN1L, RAP2C, PRPF4B</i>	Cluster <i>miR-24-1–miR-23b</i> FRA 9D; deleted in urothelial carcinoma ¹³
9	<i>miR-29b-2</i>	1q32.2–32.3	<0.001	Low	NA	
10	<i>miR-146</i>	5q34	<0.001	High	<i>NOVA1, NFE2L1, C1orf16, ABL2, ZFYVE1</i>	
11	<i>miR-16-1</i>	13q14.3	<0.001	High	<i>BCL2, CNOT6L, USP15, PAFAH1B1, ESRRG</i>	Cluster <i>miR-15a–miR-16-1</i> Deleted in CLL and prostate carcinoma ¹⁰
12	<i>miR-16-2</i>	3q26.1	<0.001	High	Same as for <i>miR-16-1</i>	Identical to <i>miR-16-1</i>
13	<i>miR-29c</i>	1q32.2–32.3	<0.001	Low	NA	

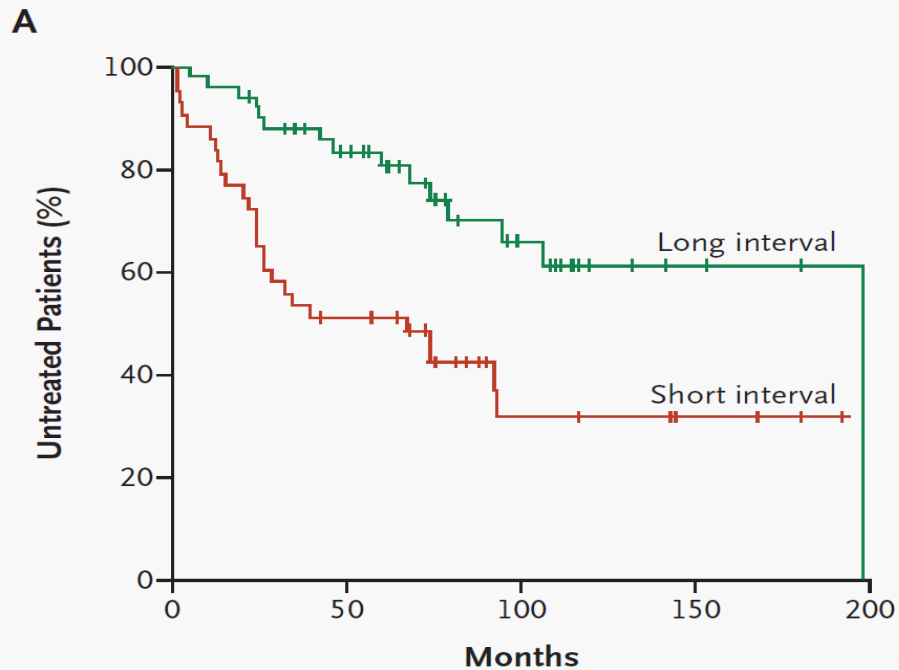
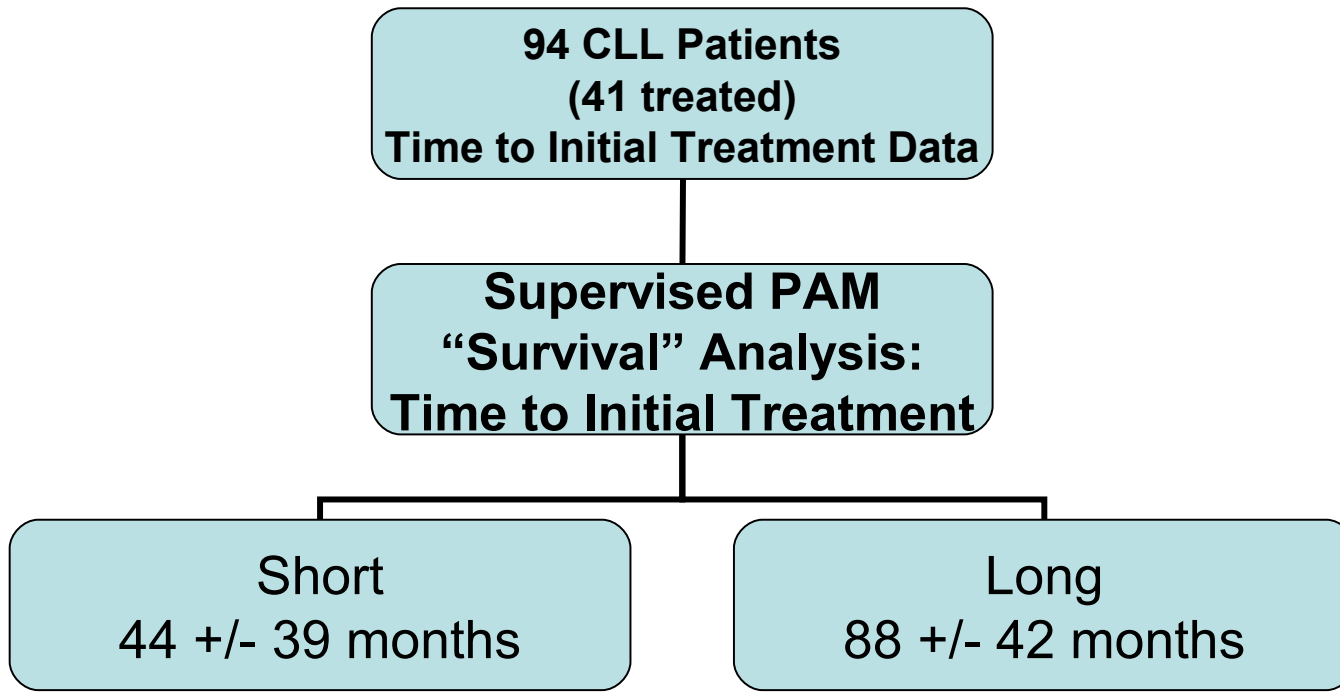



LÉKAŘSKÁ FAKULTA MASARYKOVY UNIVERSITY
Interní hematologická klinika LF MU a FN Brno
Centrum molekulární biologie a genové terapie



Děkuji za pozornost

MUDr. Mgr. Marek Mráz
marek.mraz@email.cz

26/11/10 CMBGT, Microarrays



INVESTICE DO ROZVOJE VZDĚLÁVÁNÍ

Tato prezentace je spolufinancována
Evropským sociálním fondem
a státním rozpočtem České republiky