

MUNI
MED

Psychopathology

Seminars from Psychiatry - VLA

Prof. MUDr. Tomáš Kašpárek Ph.D.

Outline

- Introduction – why, what, how
- Domains of psychopathology

Aim – learning outcomes

- To learn the vocabulary – symptoms of mental illness
- To learn the concepts of discrete psychological functions
- To learn the description of major and most frequent symptoms

- Next lecture: how to examine a patient

Norm and pathology

□ Personal

- Subjective ego-dystonic experience
- Significant change in habitual experience and behaviour
 - Does not need to be realised – recognized by peers

□ Cultural

- Conformist and non-conformist behaviour
 - Usual behaviour and experience corresponding to the culture and individual's position within it
 - Non-conformity is not a sign of psychopathology

□ Typical clinical pictures = overt signs of mental illness

- Hallucinations, catatonia...

□ Always search for the reason of behaviour: “Why”?

Domains of psychopathology

- Personality
- Affect, emotions
- Cognition
 - Attention, memory and learning, perception, thinking and decision making
- Behavior

M U N I
M E D

Perception

Perception

- Illusions - distortions
- Hallucinations – absence of stimuli
 - Sensory modality
 - Auditory: 3rd person perspective, commenting, imperative, contrary
 - Visual: simple (flashes...), complex scenes, microzoopsia...
 - Tactile, Gustatory, Olfactory, Movements
 - Intrapsychic hallucinations (see delusions of control)
 - Thought broadcasting, thought imputation/amputation, thought echo's
 - Location/source of hallucinations – inadequate (from a teeth, toe...)

Abnormal autonomy

Auditory hallucinations associated with the activation of T-P and F cortex

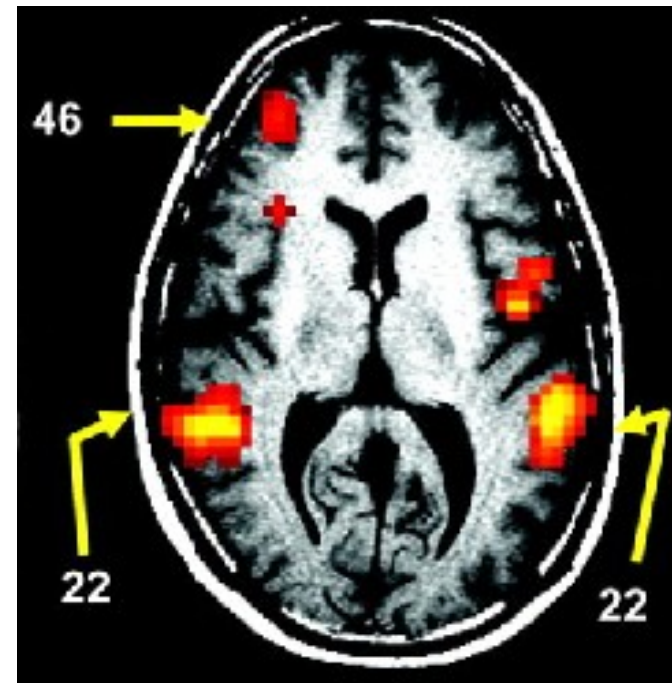

Abnormal coordination of sensorimotor cortex

- Corollary discharge:
 - a copy of the motor plan sent to the sensory cortex (“efference copy”)
 - the ensuing perception pattern recognized as resulting from a self-generated action
- ...we are not able to tickle ourselves...
- Absence of the “efference copy” in the sensory cortex = perception of exogenous origin
- Schizophrenia: inner voice = hallucinations

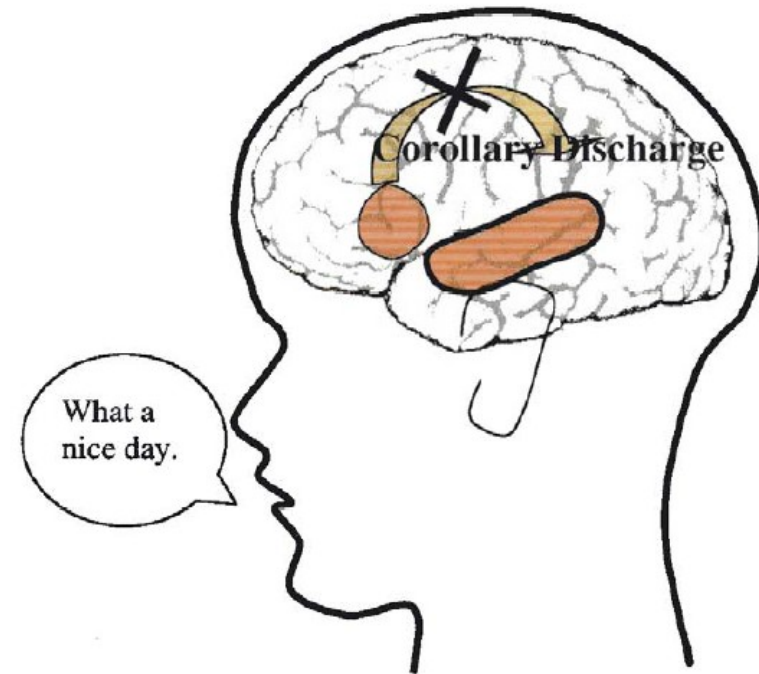

M U N I
M E D

Thought disorders

Quantitative disturbances: Speed

Decrease

- slowing of the flow of associations, slowed and diminished verbal production (bradypsychism)
- blocking of thoughts - cessation of the flow of associations (patient stops the verbal production without any recognisable impulse from surroundings)

Increase

- flight of thoughts: excessive speed of thinking manifested as extreme speed in speech (= logorrhoea)

Quantitative disturbances: Structure

- perseverative thinking
 - involuntary persistence of response to some question or topic, verbigeration - a meaningless repetition of specific word or phrase
- circumstantiality
 - indirect speech that is delayed in reaching the point, characterised by an overinclusion of details
- tangentiality
 - patient never gets from desired point to desired goal
- illogical (paralogical) thinking
 - thinking containing erroneous conclusions or internal contradiction
- neologism
 - new word created by the patient often by combining syllables or other words
- incoherent thinking
 - thought that is not understandable
 - word salad: incoherent mixture of words and phrases

Impairment of associations/abstract thinking - semanting priming

- loosening of associations: tangentiality, paralogic thoughts
- absence of abstraction - hyperconcretism
- Semantic priming: automatic (implicit) memory systém
 - tunes your associations based on current content of mind
 - network of representations (words, meanings)
 - optimal performance = focused activation around the network node

Lexical decision task

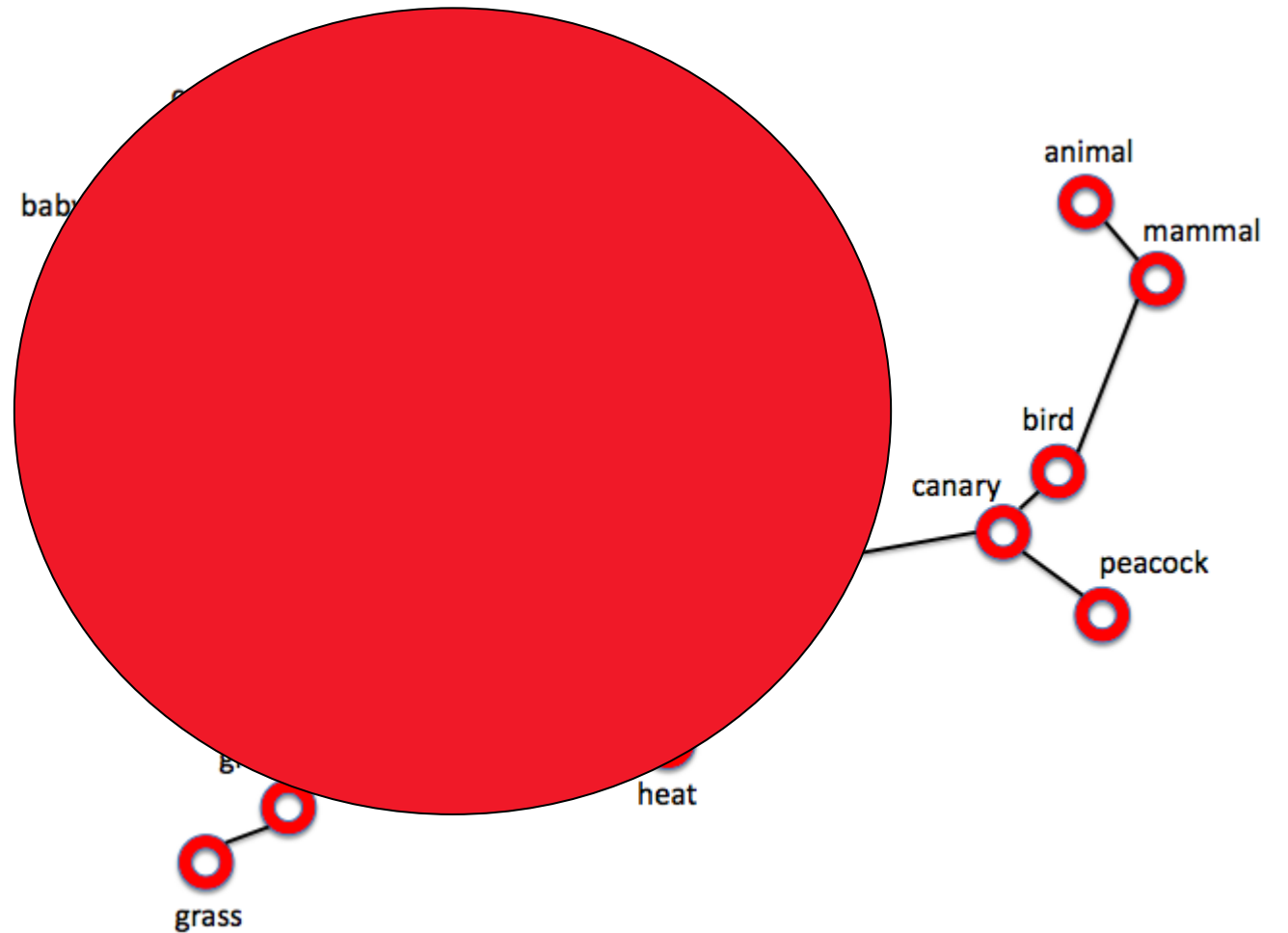
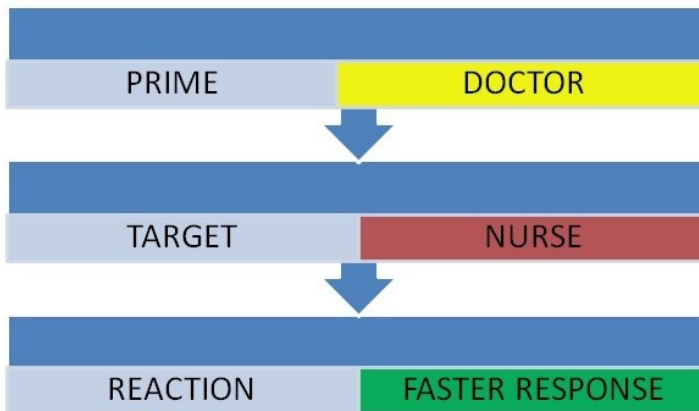
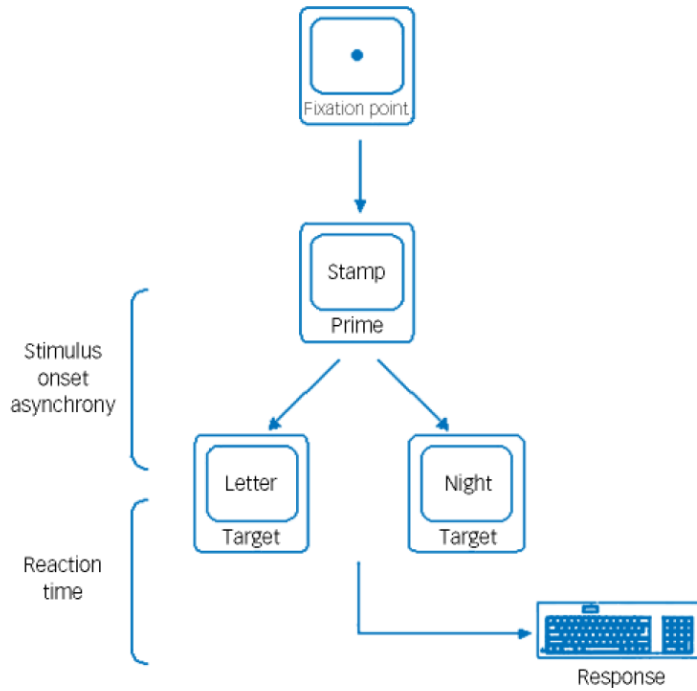

DA in cortical networks: SNR
...focus of activation in the network

Semantic priming and Formal Thought Disorder

- Meta-analysis of 36 studies (Pomarol-Clotet et al., 2008)
 - SCH vs. NC $d = 0,7$ (95% CI $-0,02 - 0,16$)
 - FTD vs. NC $d = 0,38$ (95% CI $0,21 - 0,55$)

= increased priming in FTD – fast response to distant words
= more extensive network activation
= loosening of associations

Qualitative disturbances: content of thoughts, believes

Delusions

= False beliefs

- inadequate/bizarre content
- based on incorrect inference about external reality
- not consistent with patient's intelligence and cultural background
- cannot be corrected by reasoning
- influence on behaviour

Formation (development)

- Delusional mood – feeling that something is wrong, different, unreal
- Delusional perception – things have special meaning, perceived as significant
- Making sense out of it = "AHA", delusion formation

Basal DA pathology in SCH

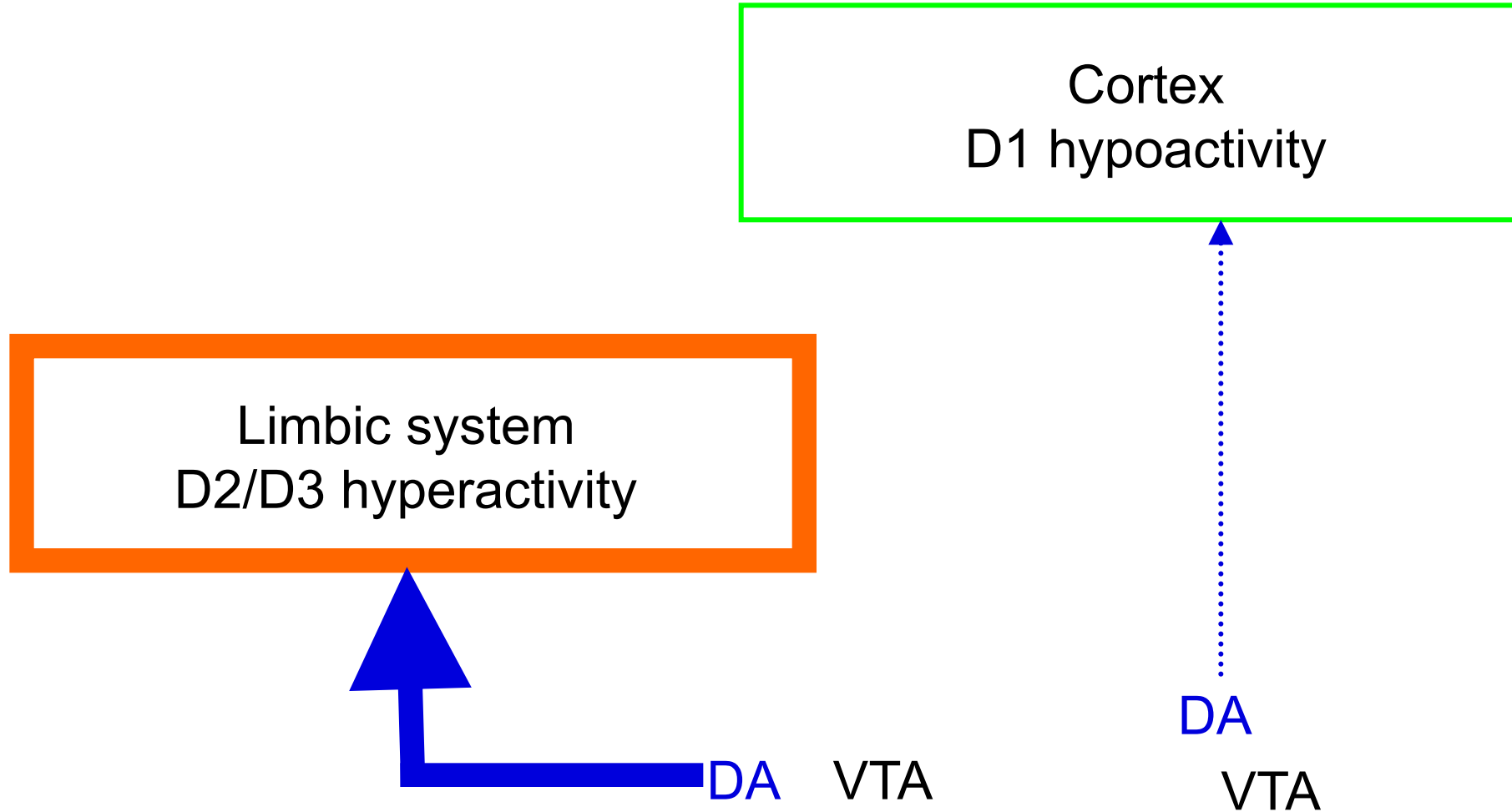

DA system regulation

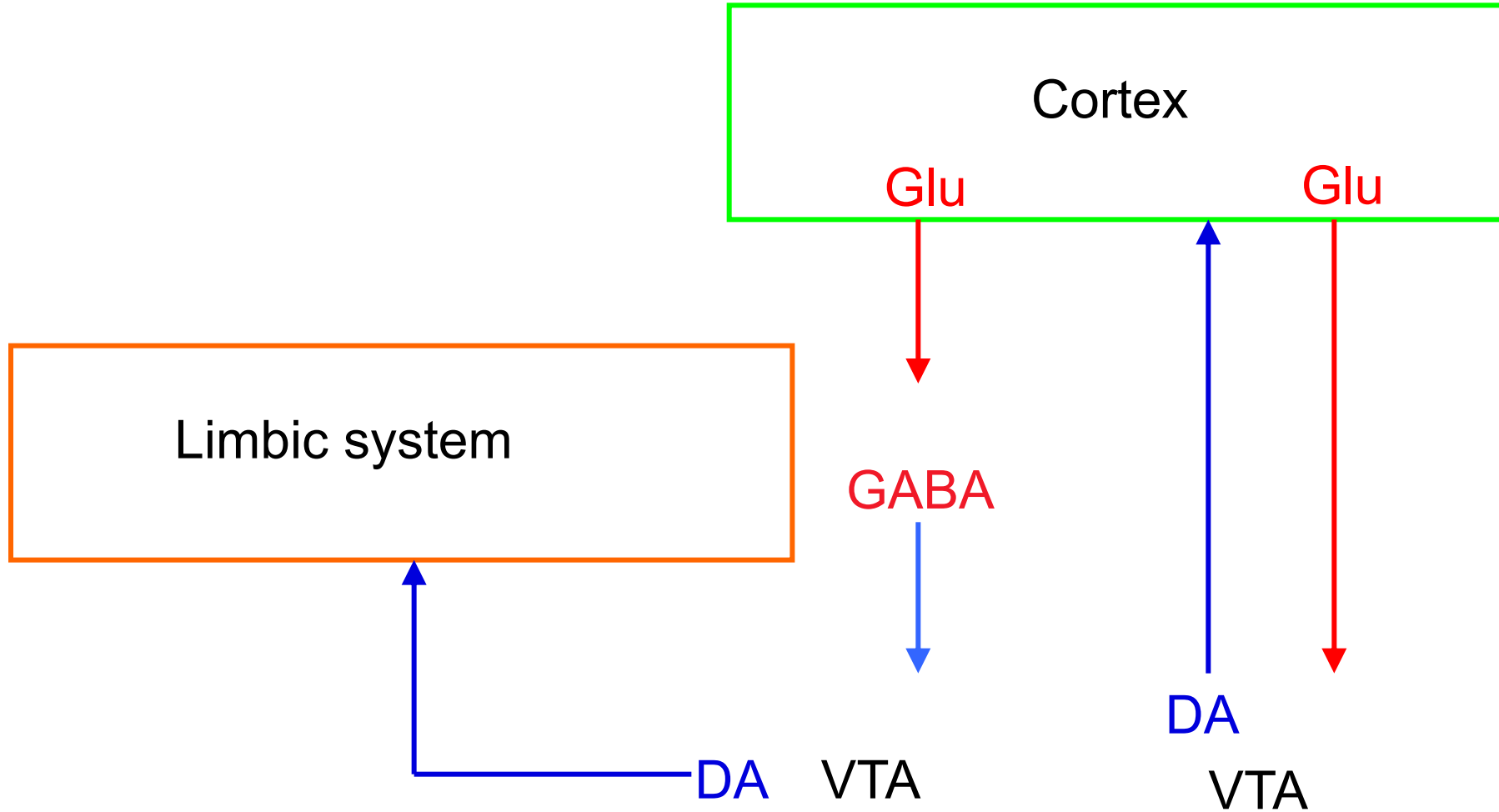

SCH – DA system dysregulation

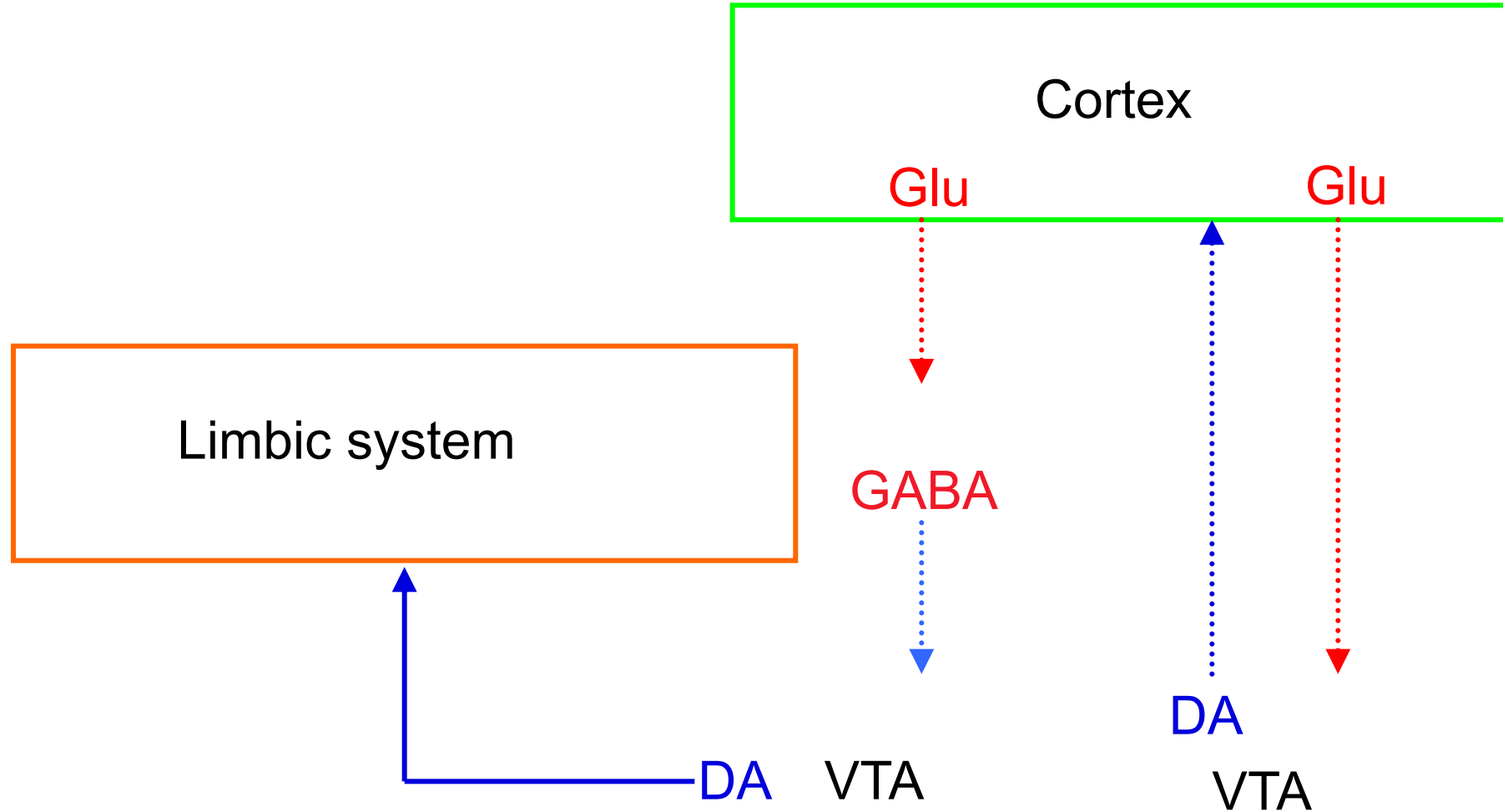

Why does psychosis develop?

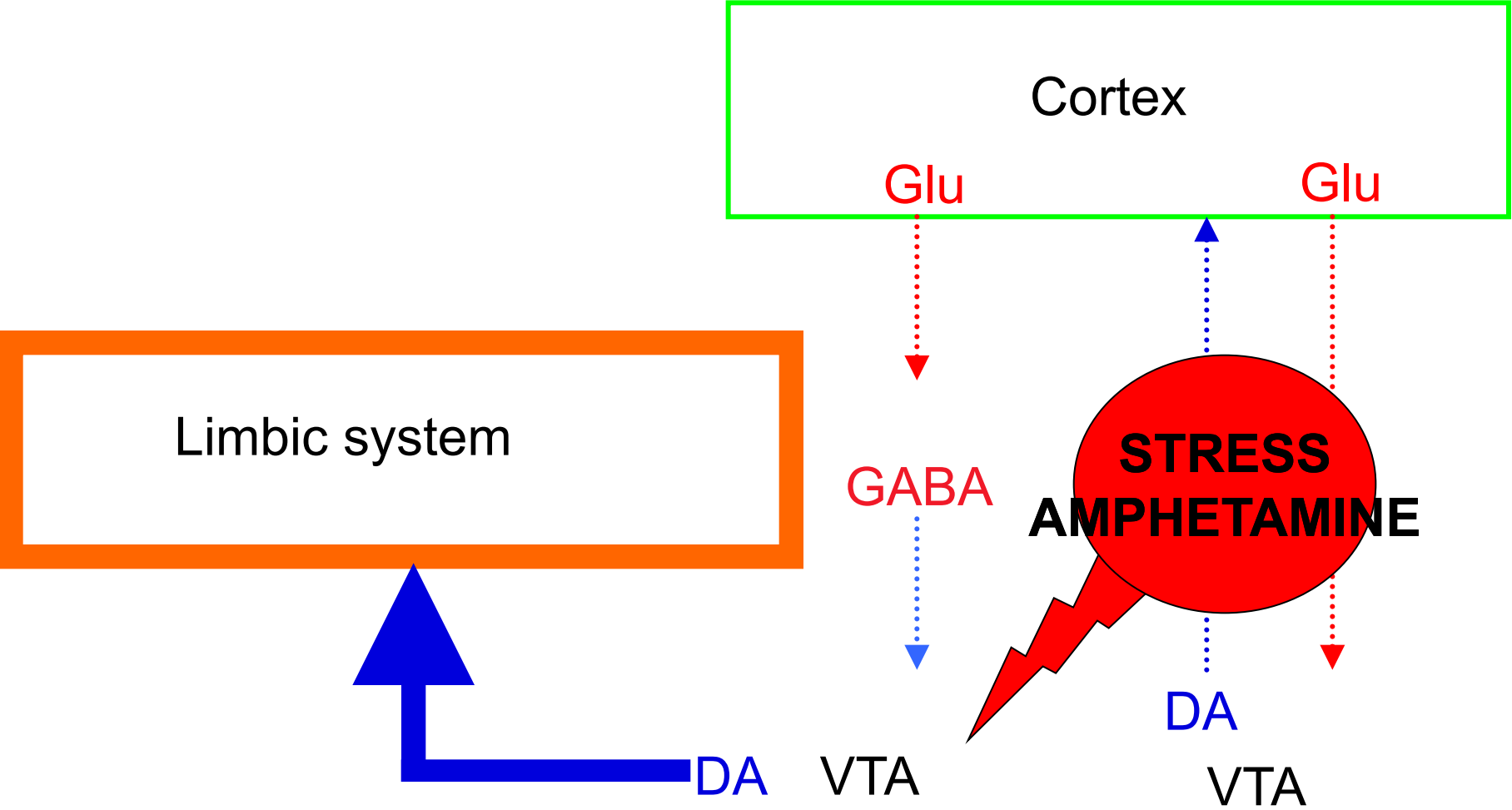

Mesolimbic DA hyperactivity = psychosis

- Mesolimbic DA system signals the importance (saliency) of a stimulus
 - i.e., which perceptions, thoughts... are important and which of them are not;
 - which ones deserve attention (“attribution of saliency”)
 - automatic process: you have no control over it, you cannot recollect willingly - insight
 - experiential quality: ‘you know it by heart’
- Dysregulation in SCH – inadequate attribution of importance to neutral stimuli
 - Delusions = explanation of abnormal significance

D2R blockade = antipsychotic

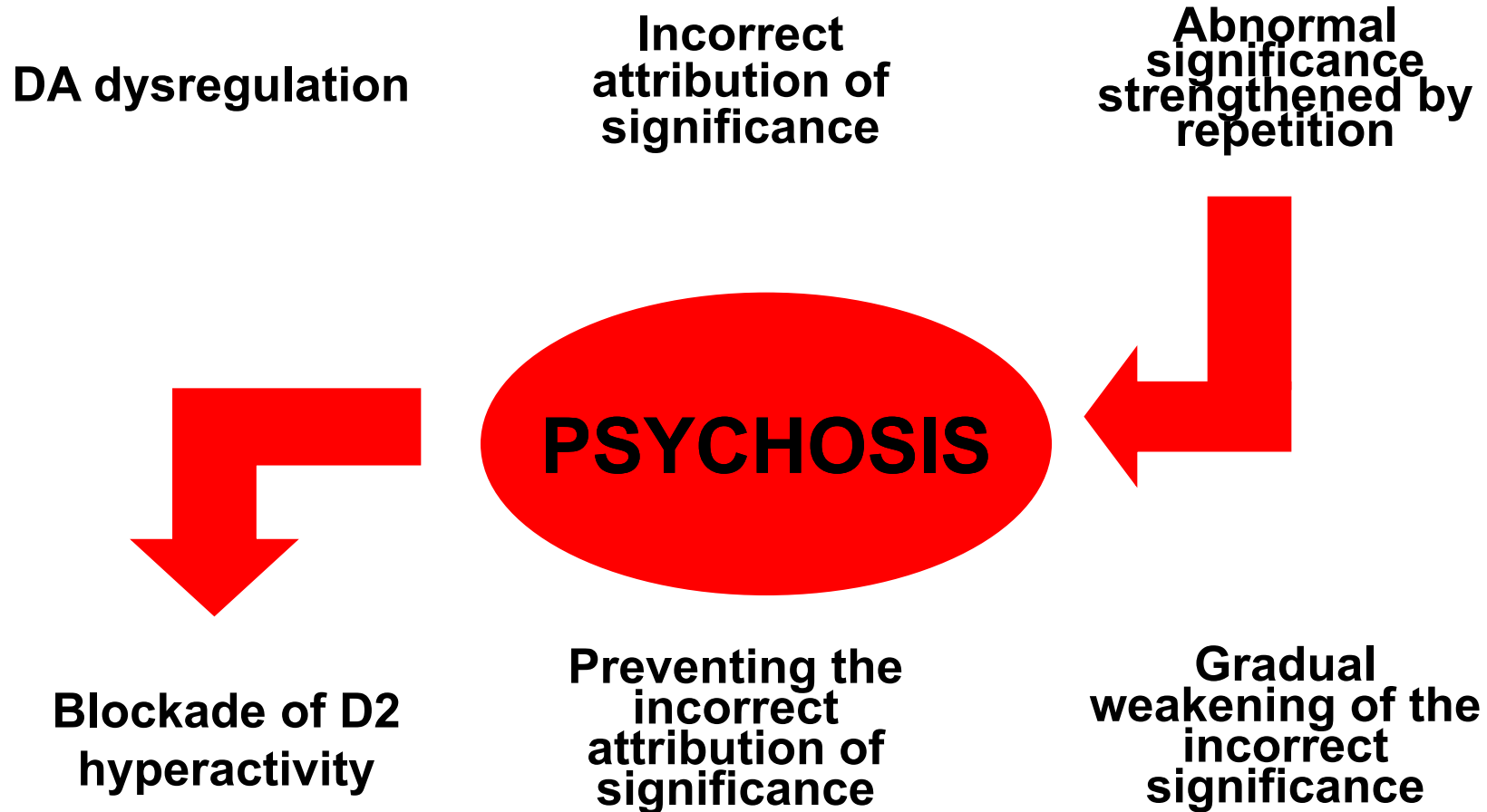

Melancholic delusions (depressive)

- delusion of self accusation
 - false interpretation of real past event resulting in feeling of guilt
- hypochondriac delusion
 - false belief of having a fatal physical illness
- nihilistic delusions
 - false feeling that self, others or the world is non-existent or ending
- delusions of failure
 - false belief that one is unable to do anything useful
- delusion of property (ruin)
 - false belief that one lost all property

Delusions of grandeur (manic)

- delusion of importance

- exaggerated conception of one's importance

- delusion of power, extrapotence

- exaggerated conception of one's abilities/possibilities

- delusion of identity

- false belief of being the offspring of member of an important family

Paranoid Delusions

- based on ideas of reference (false ideas that behaviour of others refers to a patient):
 - delusion of persecution
 - false belief that one is being persecuted
 - delusion of infidelity
 - false belief that one's lover is unfaithful
 - erotomanic delusion
 - false belief, that someone is deeply in love with them

Delusions of control

= false feeling that one's will, thoughts, feelings, or movements are controlled by another agent

- thought withdrawal

- false belief that one's thoughts are being removed from one's mind by other people or forces

- thought insertion

- false belief that thoughts are being implanted in one's mind by other people or force

- thought broadcasting

- false belief that one's thoughts can be heard by others

- thought control

- false belief that one's thoughts are being controlled by other people or forces

Obsession

- persistence of an irresistible thought, repetitive thought
- ego-dystonic
- stereotypical, monotonous
- cannot be eliminated from consciousness by will
- associated with anxiety, interferes with directed behavior, attention

vs. **preoccupation of thought**: certain idea is in the centre of thinking, is coming back, usually associated with a strong affective tone (date, money, success...)

Function of the brain in OCD

Meta-analysis of fMRI studies (Menziés et al., 2008)

Hyperfunction of OFC (BA 10, 47), AC (BA 32), the motor area (BA6), PostCing (BA 30), PreCun (BA7), OC, NcCaud, Thal

Hypofunction of OFC (BA 47), AC (BA 32), Ins, PFC (BA44), NcCaud, Putamen, HIP, CRBL

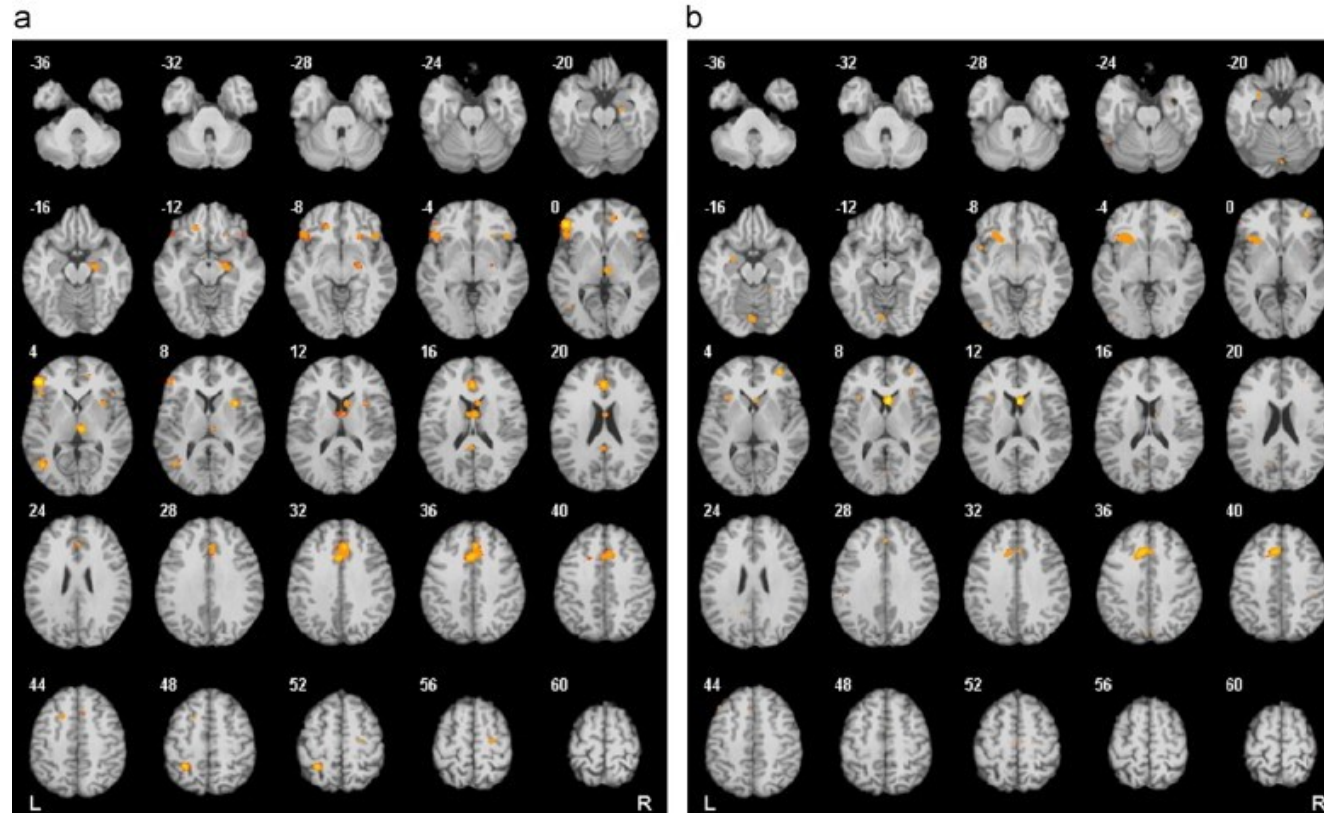

Functional implication

□ **OFC hyperactivity**

- the OFC encodes the representations of values (positive, negative; representations as well as operations)

□ **cognitive styles (“evaluation”)**

- inflated perception of responsibility
- overestimation of danger

□ **Treatment (SSRI, BT) = decrease in ↑ in the OFC, AC, NcCaud, Thal** (Swedo et al., 1992; Schwartz et al., 1996)

= goals of NCH and DBS in patients resistant to treatment

- cingulotomy (anterior), capsulotomy (anterior limb), subcaudate tractotomy, limbic leucotomy (cingulotomy + subcaud. tractotomy)
- DBS OCD = chron. stimulation of ant. limb of int. capsule
 - ca 60% of patients resistant to conventional treatment respond to DBS! (Greenberg et al., 2008)

Other disturbances of content of thoughts

overvalued idea:

- unreasonable, sustained false belief maintained less firmly than a delusion

poverty of content:

- thought that gives little information because of vagueness, empty repetitions, or obscure phrases

symbolic and magical thinking

- real objects have other, symbolic meaning, in magical thinking words, situations, action have special power and meaning

autistic (dereistic) thinking

- preoccupation with inner, private world

M U N I
M E D

Memory

„Life cycle“ of a memory trace

- Immediate memory
 - information stored for 15-20s
- Short-term memory
 - consolidation of the memory trace – several minutes to 2 days
 - medial temporal structures
- Long-term memory
 - formed trace
 - large cortical areas

„Quantitative“ dysfunctions

- **Amnesia:** short/long-term memory impairment in a state of normal consciousness
 - anterograde: failure to form new information
 - retrograde: failure to recall old information
 - organic (head trauma, tumor, surgery etc.)
 - dissociative amnesia:** patchy or selective - inability to recall previously learned information with normal functioning in the present (normal learning)
- **Hypomnesia**
- **Hypermnnesia:** unusually vivid memory
 - mania, posttraumatic stress disorder (intrusive memories), obsessive or paranoid personality traits

Imaging repressed memories

- 37-year-old female patient with conversion paralysis
 - premature birth with normal development
 - dysfunctional family, from 4 years children's homes, reports sexual abuse
 - problem behaviour in adolescence, self-mutilation, TS
 - numerous unqualified jobs

- sudden development - a month after her daughter's TS,
immediately after her boyfriend's announcement he was leaving
 - "while we talked, something clicked in my head" and she collapsed, did not communicate for several minutes
 - she woke up with right-sided paresis and anaesthesia - negative neurological + imaging examination

Assessment of life events and fMRI

□ significant life events

- daughter's TS, break-up
- break-up = “pathogenetic event” (clinical significance, relation to development, potential for secondary gain...)
- in contrast, subjectively **not too significant**: repression of emotions

□ fMRI paradigm

- sentences/comments concerning 2 severe events and 1 non-severe life event; untrue statements: forces the patient to recall details of the event
- contrasts
 - severe x non-severe event
 - TS of the daughter x break-up of the relationship

Findings

- memory of the break-up vs. TS and a neutral event
 - higher activation of
 - the amygdala – emotional activation
 - the anterior cingulum (BA 32) – automatic regulation of emotions
 - inferior frontal gyrus (BA46) – cognitive area
 - premotor areas – preparation of the motor plan
 - higher deactivation of
 - the left motor cortex (BA4) – area corresponding to motor deficit

- The neurophysiological correlate of clinically evident repression of emotions related to signif memories
 - in contrast to insuff. subj. experiencing of the breakup, high emotional activation and at the same time reduced activity is apparent in the motor cortex in the area responsible for innervation of the region with the deficit

„Qualitative“ dysfunctions

- paramnesias – retrospective falsification of memories during its **recollection** (awareness of recalled memory, failure to proper class time and situation of memory acquirement)
- confabulation – filling memory gaps with inaccurate information; frontal lobe and self-monitoring?
- deja vu – sensation of previously experienced situation when experiencing the first time
 - false awareness of memory
 - common in normality, increased in fatigue, intoxication, complex partial seizures

Dementia

- **persistent diminution of cognition in the setting of a stable level of consciousness**
- **three main symptomatic domains:**
 - neuropsychologic: cognitive decline
 - neuropsychiatric: behavioral and psychological symptoms
 - activities of daily living

Dementia – General cognitive dysfunction

- memory**: learning, recall, recognition
- executive functions: planning, flexibility
- thought disorders and language (disorganized structure, fluency...)
 - perseveration** (following a topic after its change), **echolalia** (repetition of other's speech)...
 - abstraction (concrete thinking...)
- judgment, insight (non-realistic planning, judging situations...)
- attention: shift of attention, distractibility
- visuospatial abilities (reproduction of a complex drawing...)
- higher cortical functions - gnosis and praxis: apraxia, agnosia, aphasia

Amnestic disorders

Characteristics

- **Definition:** acquired **impaired ability to learn** and recall new information (and past events sometimes)
- **No attention deficit or clouding of consciousness** (delirium), **no other cognitive dysfunction** (dementia)
- Secondary syndromes caused by systemic medical or primary cerebral diseases, substance abuse disorders, medical adverse effects

Etiology

- Diencephalic and middle temporal lobe structures (mammillary bodies, hippocampus)
- Causes of amnesic syndrome:
 - closed head trauma
 - penetrating missile wounds
 - focal tumors
 - surgical intervention
 - herpes simplex encephalitis
 - infarction of the territory of the posterior cerebral artery
 - hypoxia
 - chronic use of alcohol with thiamine deficiency
- Transient forms – linked with CVS disorders, pathology in the vertebrobasilar system, episodic physiologic or metabolic disorders, acute intoxications, seizures

Clinical notes

Transient global amnesia

- episodes of transitory inability to learn new information (to form memories)
- variable inability to recall memories from the episode
- restoration to completely intact cognitive state
- no behavioral changes x may be confusion, perplexity
- sudden/gradual onset – according to the cause (head trauma, CNS event, chronic toxic exposure)
- disorientation – may be to place and time due to severe mnestic disorder x spared orientation to person (dementia)
- lack of insight
- confabulations**

M U N I
M E D

Delirium

Characteristics

- **transient cognitive disorder**
- **core features:** impairment of **consciousness** with **attention deficit, rapid onset, fluctuating course.**
- other phenomena may appear more prominent, but are not always present
 - psychomotor changes (agitation), perceptual changes as illusions and hallucinations, disorganized thought, delusions, disturbances of sleep, emotional changes (irritability, flatness of emotions)...

M U N I
M E D

Disturbances of emotions

Emotions - terminology

Emotion

- complex feeling state
- Psychic, somatic, behavioral components

Affect

- short term emotional/affective state

Mood

- longer term emotional/affective state

Disturbances of emotions

- Range of emotional states
 - flattening of emotions
 - decreased emotional reactivity
- Emotional tenacity
 - Lability
 - Incontinence
- Appropriateness
 - incongruent emotions
- Ambivalence – contrary emotions

Disturbances of affects

Pathological affect

- intensive emotional reaction
- behavioral changes - aggressivity
- short period of qualitative disorder of consciousness (obnubilation)
- amnesia

Uncontrolled affect

- no changes of consciousness, no amnesia

Disturbances of moods

- Anxiety, phobia, fear
- Depression
- Mania

Depression - syndrom

Affective symptoms

- depressed mood – bad, down, black, oppressive – distinguish from sadness
- anhedonia
- (anxiety)

Motivation

- loss of interest in usual activities
- inability to perform, initiate activity (abulia)

Cognitive

- evaluation, self-esteem
- attention, memory
- negative cognitive biases

Suicidal activity – hopelessness, suicidal thoughts etc.

Vegetative, „somatic“

- insomnia, anorexia. decreased libido, loss of energy and fatigue, psychomotor retardation

Mania - syndrom

Affective symptoms

- expansive moods: mania, euphoria, irritability, dysforia

Cognitive

- increased speed vs. decreased accuracy: cognition (flight of ideas), memory (hypermnnesia), speech (pseudoincoherence), decisions (risky)...
- distractibility
- inflated unrealistic self-esteem

Behavioral

- hyperactivity, restlessness
- overinvolvement – socially, sexually, occupationally...

Vegetative, somatic

- insomnia (decreased need to sleep), anorexia (decreased need to eat), increased energy

M U N I
M E D

Catatonia

Disturbance of voluntary movements

“Positive“

- agitation
- active negativism
- mannerism (odd caricature of normal movements)
- stereotypies (repetitive, nonsensical movements)
- grimacing
- echolalia, echopraxia

„Negative“

- mutism
- passive negativism
- catalepsy (passive induction of a posture held against gravity)
- posturing (spontaneous and active maintenance of posture against gravity)
- waxy flexibility (slight and even resistance to positioning by examiner)
- stupor (no psychomotor activity)

Next steps – clinical vignettes

□ Have a look at videos:

- Depression: <https://www.youtube.com/watch?v=4YhpWZCdiZc>
- Mania: <https://www.youtube.com/watch?v=zA-fqvC02oM>
- Hallucinations: <https://www.youtube.com/watch?v=0tn8xLQY53U>
- Hallucinations and delusions: <https://www.youtube.com/watch?v=ZB28gfSmz1Y>
- Delirium: <https://www.youtube.com/watch?v=IjH1AoVuVS0>
- Delirium: https://www.youtube.com/watch?v=hwz9M2jZi_o
- Anxiety: <https://www.youtube.com/watch?v=li2FHbtVJzc>
- Panic attack: https://www.youtube.com/watch?v=9YaS_4tXBNU
- Catatonia: https://www.youtube.com/watch?v=_s1lzxHRO4U
- Obsessions, Compulsions: <https://www.youtube.com/watch?v=xMwOLOPFKIM>
- Obsessions, Compulsions: <https://www.youtube.com/watch?v=syM6XYzht20>
- Conversion: https://www.youtube.com/watch?v=_jOuqAcgMrA
- Suicide: https://www.youtube.com/watch?v=A-m_alQfXZA

Děkuji za pozornost