

# Medical Biology II

**Introduction to genetics I – genetics in medicine,  
Mendelian Inheritance, autosomal and gonosomal  
Inheritance, chromosome abnormalities**

**Ondřej Slabý, Kateřina Straková**

*Department of Biology Faculty of Medicine, MU*

**M U N I  
M E D**

# The role of genetics in medicine

**Clinical genetics** is a medical field dealing with diagnosis, treatment and comprehensive care of patients with hereditary diseases.

**In 21st century genetics principles are important in the practice of all medical disciplines:**

To transfer the enormous advances in genetic research to real clinical benefit for patients and their families, all physicians should understand the basic principles of genetics.

The main aspect of clinical genetics is the focus not only on the individual patient, but on his **whole family**. **A detailed family medical history** is the first important step in the examination of any disease, not only a genetic disease.

Virtually every disease is the result of the combined effects of the **genetic background** and the **environment**, whereas the significance of the genetic component may be greater or lesser.

We can distinguish three main types of diseases that are completely or partially caused by genetic factors:

1. **Monogenic diseases (Mendelian inheritance)**
2. **Chromosomal disorders**
3. **Multifactorial diseases**

# Basic genetic terminology

## Classical genetics

- summarizes the basic principles of heredity;
- **the genotype of the individual is determined based on the observed phenotype (from phenotype to genotype)**
- basic assumptions of formal genetics
  - **diploidy** of the studied organism (two sets of chromosomes in somatic cell nuclei)
  - localization of the studied gene on asexual chromosomes (**autosomes**)
  - absolute correlation between the form of the gene and the resulting trait (**100% penetrance**)

**Gene** - part of a DNA molecule carrying genetic information for the synthesis of a specific protein (structural gene)

**Genotype** - a summary of all genetic characteristics of an individual.

- Concrete forms of the studied gene present on the maternal and paternal chromosome of a homologous pair - notation of both alleles of particular gene on homologous chromosomes of an individual

**Allele** - a specific form of a gene, in a diallelic system only two situations can occur in a given individual genotype AA or aa - **homozygous**, genotype Aa - **heterozygous**















**Phenotype** - a set of all characteristics of an individual; in the narrower sense - a specific form of a trait, determined by concrete genotype, eventually modified by the external environment

A **zygote** is a cell with a complete set of chromosomes (in humans it means a set of  $2n$  - diploid - that is, each chromosome in two copies), which is formed by fertilization - fusion of gametes (**gametes**), each having a half set of chromosomes (in humans  $1n$  - haploid) .

# Milestones in the history of cell and molecular biology

## GREGOR JOHANN MENDEL (ŘEHOŘ JAN) – MENDEL'S LAWS OF INHERITANCE DISCOVERER OF BASIC LAWS OF INHERITANCE AND FOUNDER OF GENETICS

1866 Experiments with plant hybrids (in German Versuche über Pflanzen-Hybriden)

Characteristics of pea plants Gregor Mendel used in his inheritance experiments						
Seeds		Flower colour	Pod		Stem	
form	cotyledons		form	colour	position of inflorescences	size
 round roundish	 yellow	 white	 full	 yellow	 axial	 long
 wrinkled	 green	 violet-red	 constricted between the seeds	 green	 terminal	 short



Observed trait combinations:

1. **Seed shape:** round/wrinkled
2. **Seed color:** yellow/green
3. **Flower color:** white/purple
4. **Pod shape:** inflated/constricted
5. **Pod color:** yellow/green
6. **Flower and pod position:** axial/terminal
7. **Plant height:** tall/dwarf

He was a monk and later abbot of the Augustinian monastery in Old Brno.

1869 The only honor in professional scientific circles: he was elected vice-president of the Natural Science Society in Brno  
Mendel's contribution to biology was not recognized until after his death, at the beginning of the 20th century by Hugo de Vries, Carl Correns, Erich von Tschermak and especially **William Bateson** (the field of genetics).

# Mendel's experiments – principles and terminology

## Mendel performed experiments with pea (*Pisum sativum*)

The flowers have male (anthers forming pollen grains) and female organs (ovary with eggs)

The crown petals are closed down and also prevent pollen from getting out or in, thus ensuring **self-fertilization**, during which both male and female gametes from the same flower unite to produce the seeds.

## The principle of crossing and hybrid formation

He performed **emasculat**ion on the recipient of pollen, removed anthers (high variant)

He then transferred pollen from the donor to the pistil (low variant) (cross-fertilized)

The resulting seeds were sown and hybrid plants were formed.

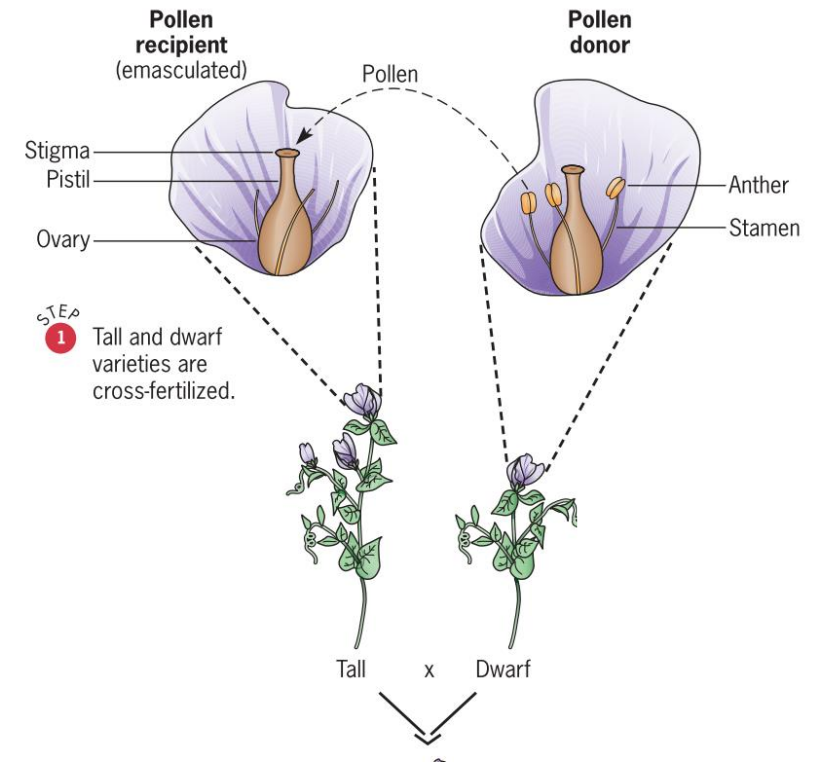

Observed trait combinations:

1. **Seed shape:** round/wrinkled
2. **Seed color:** yellow/green
3. **Flower color:** white/purple
4. **Pod shape:** inflated/constricted
5. **Pod color:** yellow/green
6. **Flower and pod position:** axial/terminal
7. **Plant height:** tall/short

# Mendel's experiments – principles and terminology

If we study only a single trait, it is a monohybrid cross or monohybridism

**P generation** - parental generation, always two different homozygotes

**F1 - generation** - the first generation of offspring (first filial generation) is created by crossing two individuals from the P generation to form heterozygotes

**F2 - generation** - the second generation of offspring (second filial generation) is created by crossing two individuals from the F1 generation

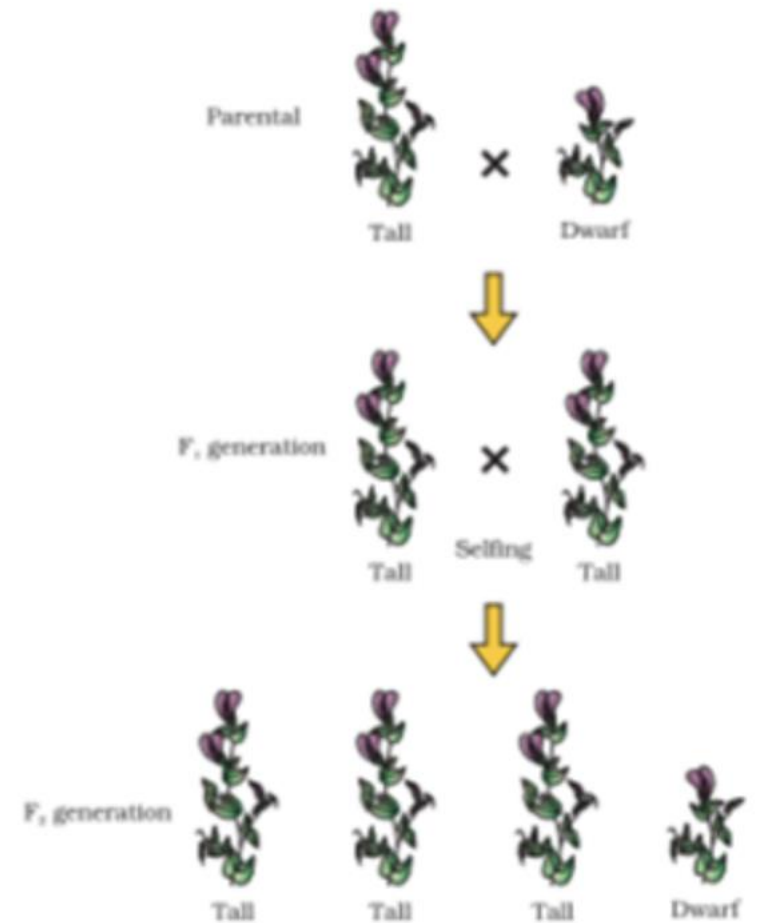

# Mendel's experiments – 1. law- uniformity of the first hybrid generation

## 1. LAW - LAW OF UNIFORMITY OF THE F1 GENERATION

- when 2 homozygotes cross each other, the offspring are genotypically and phenotypically uniform
- for 2 different homozygotes, the offspring are always heterozygous hybrids
- In a heterozygote, one allele (**dominant**) may conceal the presence of another allele (**recessive**)

## PRINCIPLE OF DOMINANCE AND RECESIVITY

**STEP 1** Each parental homozygote produces one kind of gamete.

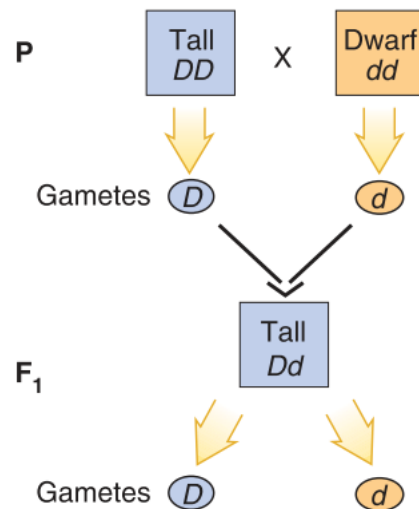

**STEP 2** The F<sub>1</sub> heterozygotes produce two kinds of gametes in equal proportions.

**F<sub>1</sub> generation**

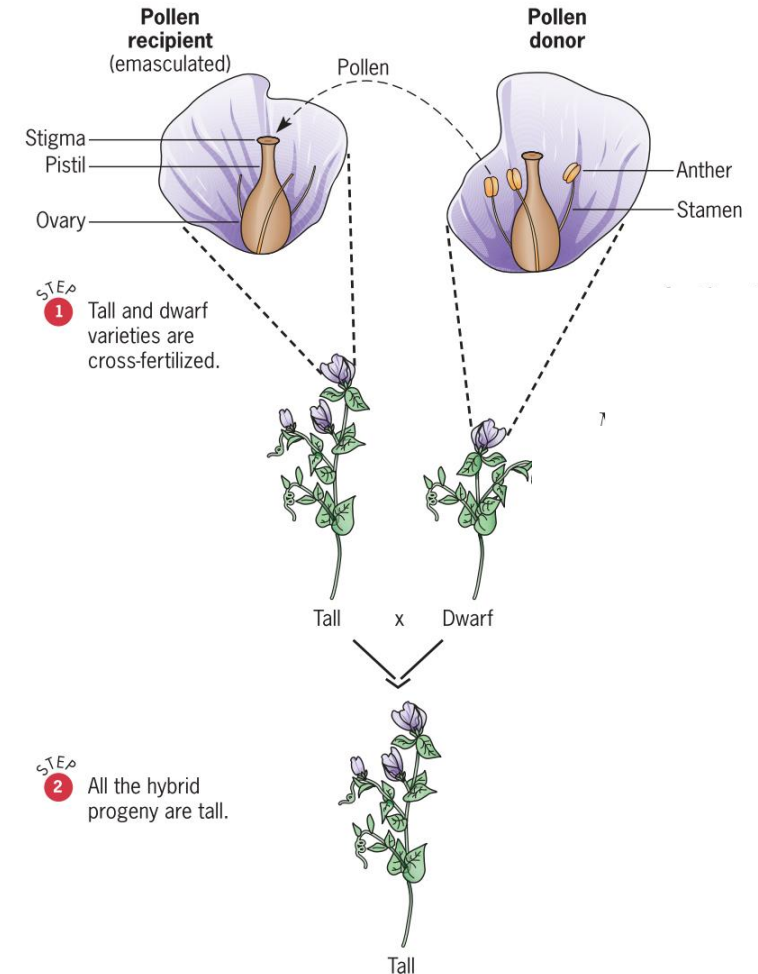

# Mendel's experiments – 2. law of segregation

## 2. LAW OF ALLELE SEGREGATION INTO GAMETES (Law of genotypic ratios in the F2 Generation)

During gamete formation, the two alleles separate and **segregate**.

If, when crossing 2 heterozygotes, each of the two alleles (dominant and recessive) can be passed to the offspring with the same probability, then the probability for the offspring genotype is:

25% (homozygous dominant individual)

50% (heterozygous)

25% (homozygous recessive individual)

- genotypic ratio 1: 2: 1

- phenotypic ratio 3: 1

**STEP 1** Each parental homozygote produces one kind of gamete.

**STEP 2** The F<sub>1</sub> heterozygotes produce two kinds of gametes in equal proportions.

**STEP 3** Self-fertilization of the F<sub>1</sub> heterozygotes yields tall and dwarf offspring in a 3:1 ratio.

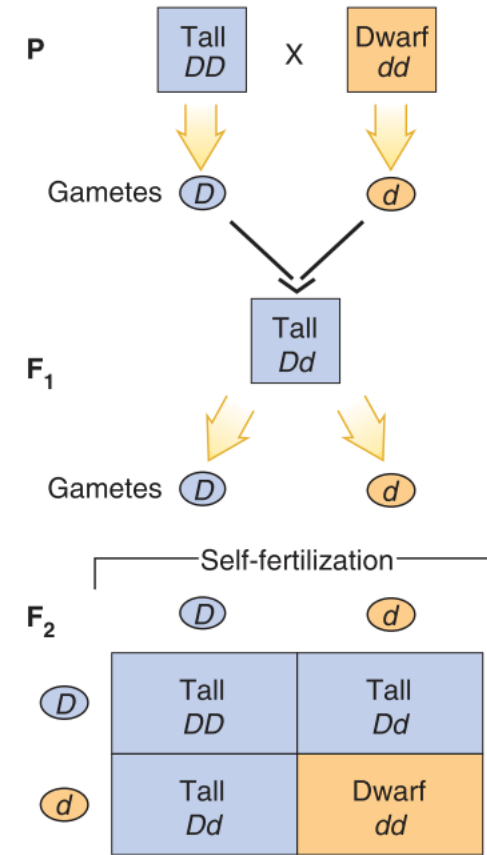

**Punnett square**

F <sub>2</sub>	Phenotypes	Genotypes	Genotypic ratio	Phenotypic ratio
	Tall	DD Dd	1 2	3
	Dwarf	dd	1	1



## Mendel's experiments – dihybridism

- If a trait is determined by one gene (locus), we speak of **monohybridism** or monohybrid crossing
- if we observe two such phenotypic traits at the same time, it is **dihybridism**
- tracking three traits is **trihybridism**, etc. - when tracking many traits, it is **polyhybridism**

**From Mendel's results of dihybrid crossings, a rule for an independent combination of alleles can be derived** - applies to genes located on different asexual chromosomes or genes located on one chromosome, but at a sufficient distance so that **gene linkage** does not apply!

# Mendel's experiments – dihybridism

The experiment is analogous to monohybridism

- parental generation P is **AABB x aabb**
- according to the principle of segregation (2.L) F1 hybrids form **four different gamete genotypes** in the **same proportions**
- after self-fertilization, **16 possible zygote genotypes** will be created, which, based on the principle of dominance and recessivity, correspond to a total of 4 types of phenotypes with ratio 9:3:3:1

## Punnet square principle

R. C. Punnett, british geneticist

For one or two genes it is possible to write all gametes and combine them with each other - a set of all possible zygote genotypes

Enable you to estimate the results of the crossing

For more complex cases (more than two genes), the method is impractical

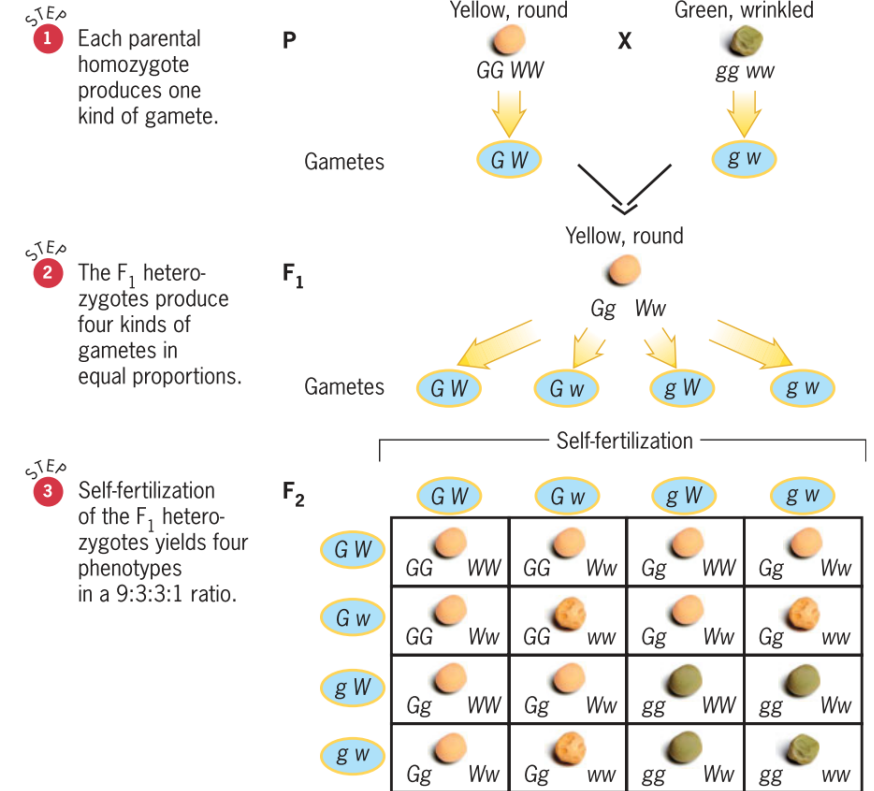





F <sub>2</sub>	Phenotypes	Genotypes	Genotypic ratio	Phenotypic ratio
Yellow, round	🟡🍷	GG WW	1	9
		GG Ww	2	
		Gg WW	2	
		Gg Ww	4	
Yellow, wrinkled	🟡🍲	GG ww	1	3
		Gg ww	2	
Green, round	🟢🍷	gg WW	1	3
		gg Ww	2	
Green, wrinkled	🟢🍲	gg ww	1	1





# Mendel's experiments – 3. law of independent assortment of alleles

## LAW OF INDEPENDENT ASSORTMENT OF ALLELES

Alleles of different genes segregate, or as we say, combine independently of each other.

- when examining 2 traits at the same time (dihybridism) the same regular generation of F1 offsprings occurs
- if we have 2 AaBb dihybrids, each can form 4 different types of gamete (AB, Ab, aB, ab)
- when these 2 gametes cross each other, 16 different zygotic combinations are created
- some combinations are repeated
- only 9 different genotypes are created, which, based on the principle of dominance and recessivity, correspond to a total of 4 types of phenotypes

F <sub>2</sub>	Phenotypes	Genotypes	Genotypic ratio	Phenotypic ratio
Yellow, round 		GG WW	1	9
		GG Ww	2	
		Gg WW	2	
		Gg Ww	4	
Yellow, wrinkled 		GG ww	1	3
		Gg ww	2	
Green, round 		gg WW	1	3
		gg Ww	2	
Green, wrinkled 		gg ww	1	1

F <sub>2</sub> phenotypes	Observed		Expected	
	Number	Proportion	Number	Proportion
 Yellow, round	315	0.567	313	0.563
 Green, round	108	0.194	104	0.187
 Yellow, wrinkled	101	0.182	104	0.187
 Green, wrinkled	32	0.057	35	0.063
<b>Total</b>	<b>556</b>	<b>1.000</b>	<b>556</b>	<b>1.000</b>

■ **FIGURE 3.5** Comparing the observed and expected results of Mendel's dihybrid cross.

# Application of Mendel's principles – forked-line method

An example of a trihybrid crossing - when Punnett square becomes impractical

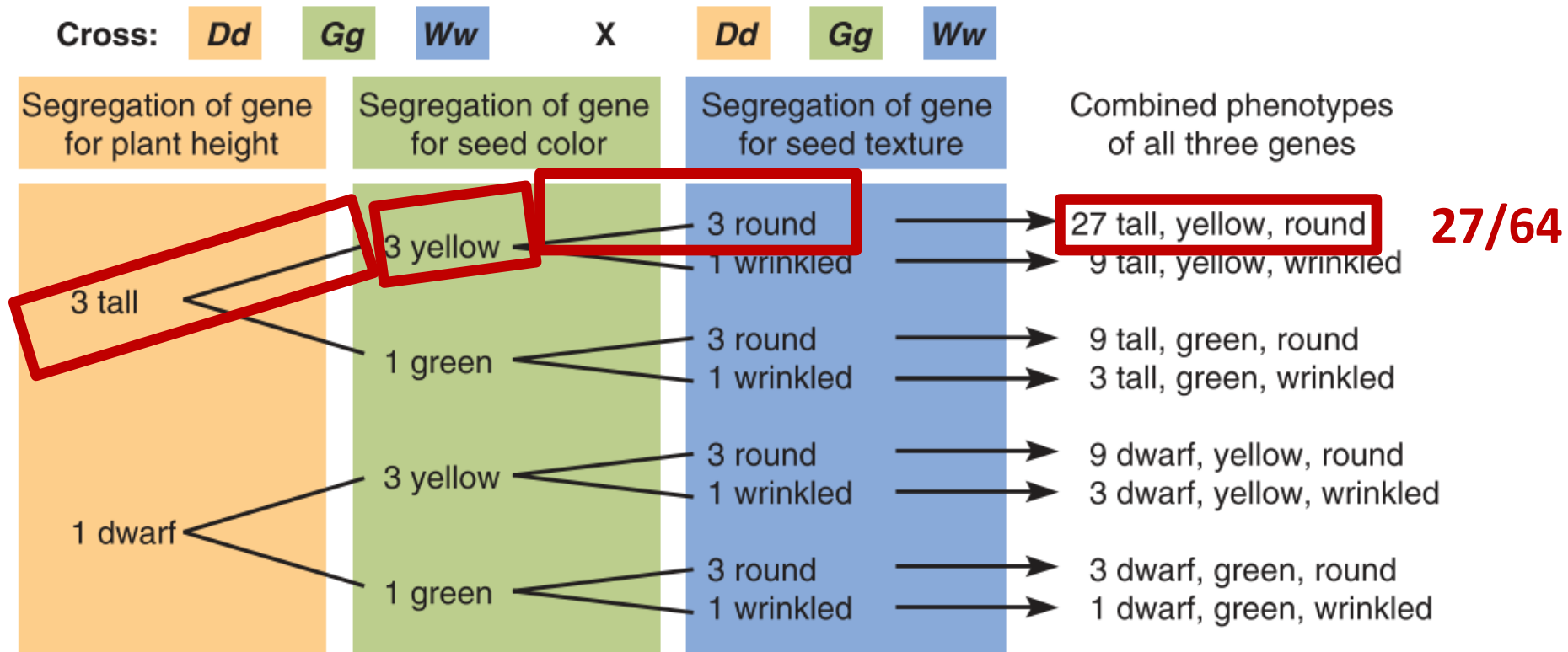

■ **FIGURE 3.6** The forked-line method for predicting the outcome of an intercross involving three independently assorting genes in peas.

# Application of Mendel's principles – probability method

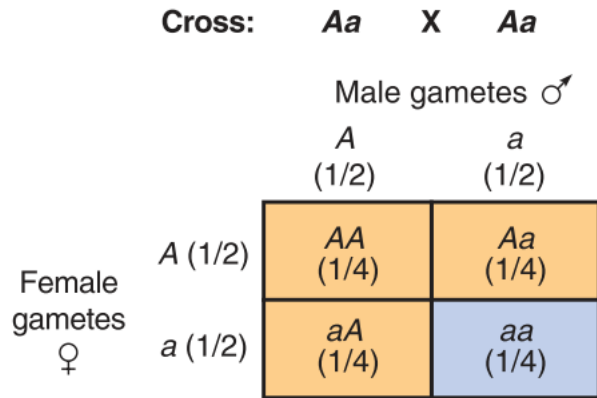

**Progeny:**

Genotype	Frequency	Phenotype	Frequency
$AA$	1/4	Dominant	3/4
$Aa$	1/2		
$aa$	1/4	Recessive	1/4

■ **FIGURE 3.8** An intercross showing the probability method in the context of a Punnett square. The frequency of each genotype from the cross is obtained from the frequencies in the Punnett square, which are, in turn, obtained by multiplying the frequencies of the two types of gametes produced by the heterozygous parents.

The probability that the zygote will be  $AA$  is equal to the probability that each of the participating gametes contains the  $A$  allele, therefore  $\frac{1}{2} \times \frac{1}{2} = \frac{1}{4}$

Probability of homozygote  $aa$  is also  $\frac{1}{4}$

The probability of heterozygote  $Aa$  is then  $\frac{1}{2}$  because there are two possibilities of the formation of  $Aa$  and  $aA$   $\frac{1}{4} + \frac{1}{4} = \frac{1}{2}$

**By applying the principle of dominance,  $\frac{3}{4}$  of the progeny will have a dominant phenotype  $\frac{1}{4}$  of offspring will have a recessive phenotype**

# Allelic interactions

## COMPLETE DOMINANCE

the phenotype of heterozygote Aa is the same as the phenotype of dominant homozygote AA

the phenotypic ratio in F<sub>2</sub> in this case is 3/4 of dominant individuals (AA / Aa) and 1/4 of recessive individuals (aa)

dominance and recessivity is a designation of the relationship between two alleles, but also a description of the dominant or recessive trait

## INCOMPLETE DOMINANCE

The heterozygote phenotype is somewhere between the phenotypes of both parents

Heterozygote differs phenotypically from both homozygotes, it is a transitional form of both extreme alternatives (petal flowers)

## CODOMINANCE

situations where the heterozygote phenotype has the characteristics of both parents in them,

both alleles encode functional forms of the protein, which are the essence of a certain trait (eg the AB blood group system).

## Incomplete Dominance

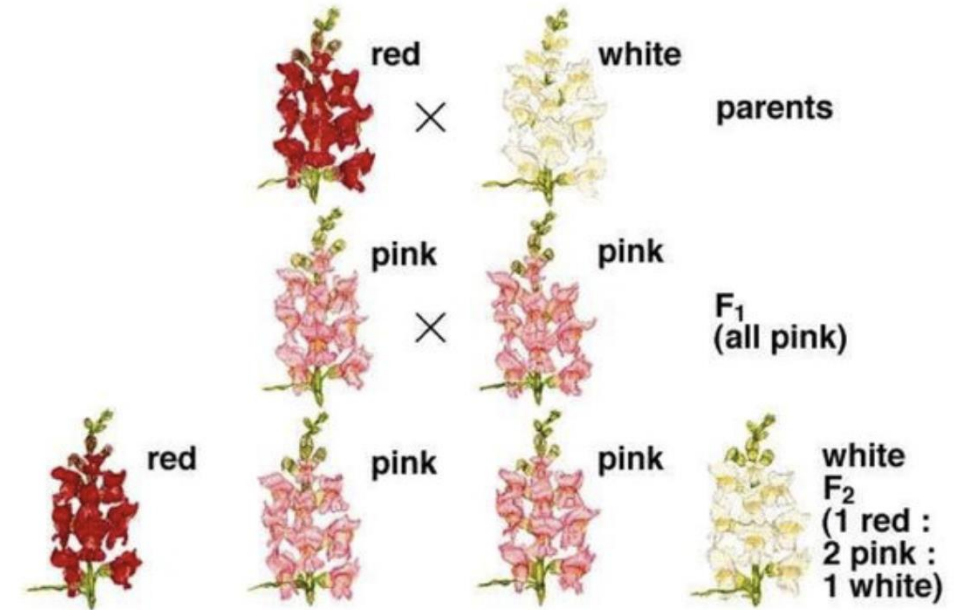

# Allelic interactions - codominance

## Blood group A,B,0

ABO system: alleles A, B, 0 - multiple alleles

Allele relations:

A to B - **codominance**

A vs 0 and B vs 0 - **dominance**

0 - **recessive**

Blood group (phenotype):    A            B            AB            0

Genotype:                    AA, A0;    BB, B0;    AB;            00

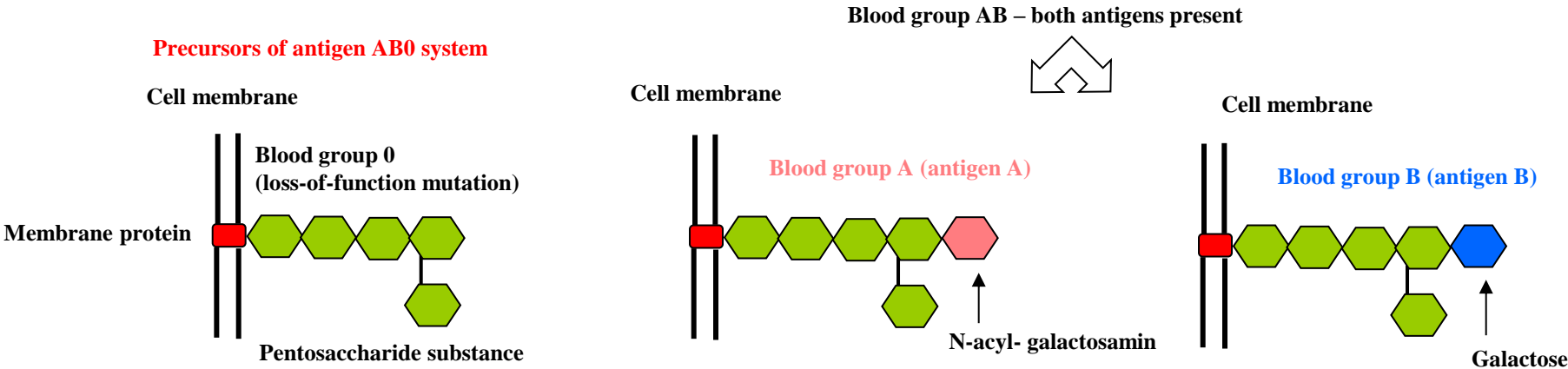

# Allelic interactions - codominance

## Heredity of blood group A,B,0 – paternity determination

Mother	Child	Potential father	Excluded father
0	A	A, AB	0, B
0	B	B, AB	0, A
0	0	0, A, B	AB
0	AB	matka vyloučena	---
A	A	A, B, AB, 0	---
A	B	B, AB	A, 0
A	0	A, B, 0	AB
A	AB	B, AB	A, 0
B	A	A, AB	B, 0
B	B	B, AB, A, 0	---
B	0	A, B, 0	AB
B	AB	A, AB	B, 0
AB	A	A, B, AB, 0	---
AB	B	A, B, AB, 0	---
AB	0	matka vyloučena	---
AB	AB	A, B, AB	0



# Non-allelic gene interactions

**Interactions between two genes** (alleles of two different genes - non-allelic gene interactions) which are involved in the phenotypic expression of one trait.

Non-allelic interactions usually lead to modification of the Mendel's phenotypic ratios 9: 3: 3: 1 in the F2 generation in dihybridism.

**Epistasis** is like a dominance in the situation of allelic interactions.

## TYPES OF INTERACTIONS

**DOMINANT EPISTASIS (12: 3: 1)** - only if both alleles of the first locus are recessive ( $aa--$ ), alleles of the second locus can be expressed phenotypically

**RECESSIVE EPISTASIS (9: 3: 4)** - only if at least one allele of the first locus is dominant ( $A---$ ), alleles of the second locus can also be phenotypically manifested

## Interactions of non-allelic genes

**COMPLEMENTARY GENES (9: 7)** - when recessive homozygosity in each of the loci leads to the same phenotype, so that individuals  $aaB-$ ,  $A-bb$  and  $aabb$  will be the same.

if the dominant alleles of both loci are present at the same time, their effects complement each other and result in a different phenotype

**DUPLICATED GENES WITH CUMULATIVE EFFECT (9: 6: 1)** - occurs when each of the dominant genotypes (homozygote or heterozygote) is responsible for the production of the same trait (eg formation of a certain amount of pigment) - then in the example of  $aabb$  pigment they produce none,  $A-bb$  and  $aaB-$  produce a unit amount of pigment and in individuals with genotype  $AB-$  the effect of dominant alleles accumulates and the largest amount of pigment is formed (two units)

**DUPLICATED GENES WITHOUT CUMULATIVE EFFECT (15: 1)** - a condition in which each of the dominant genotypes lead to the manifestation of the same trait without their effect accumulating in any way - only double recessive homozygotes will differ phenotypically, which do not carry even one of the four possible dominant alleles

## Interaction of non-allelic genes – RECESSIVE EPISTASIS

### Albinism

Pigment formation is conditioned by the interaction of two genes. One of them affects the possibility of **pigment formation**, the other a **specific color**.

The superior (epistatic) gene is the so-called chromogen C, whose **dominant allele (C)** enables the **synthesis of the enzyme tyrosinase** (an enzyme necessary for the formation of melanin pigment).

**Recessive homozygotes (cc)** do not form this enzyme and, as a result, do not form pigmentation (**albinism**).

The second gene is responsible for the specific color, we denote the B gene with *B / b* alleles; allele *B* conditions a darker coloration / allele *b* a lighter coloration.

The phenotypic ratios in the F2 generation in this type of interaction are 9: 3: 4, i.e. **recessive cc homozygotes do not synthesize tyrosinase** and thus pigment formation is prevented. Recessive homozygosity in chromogen C has an superior (epistatic) effect on phenotypic expression.

F2 generation genotypes

	<b>AB</b>	<b>Ab</b>	<b>aB</b>	<b>ab</b>
<b>AB</b>	<i>AABB</i>	<i>AABb</i>	<i>AaBB</i>	<i>AaBb</i>
<b>Ab</b>	<i>AABb</i>	<i>AAbb</i>	<i>AbBb</i>	<i>Aabb</i>
<b>aB</b>	<i>AaBB</i>	<i>AaBb</i>	<i>aaBB</i>	<i>aaBb</i>
<b>ab</b>	<i>AaBb</i>	<i>Aabb</i>	<i>aaBb</i>	<i>aabb</i>



# Penetrance and expressivity

## **PENETRANCE OF THE GIVEN FORM**

*if individuals with the same genotype show that the phenotype is manifested only in some of them, we are talking about incomplete penetrance*

- the relative number of those individuals in whom the phenotypic trait is present
- for example, in an autosomal dominant hereditary polydactyly, only 80 are found in humans between 100 Aa individuals with this disease
- the penetrance of the responsible allele is 80% - sometimes penetrance can be dependent on the age of the individual - late onset disease e.g. clinically manifested in adult age (Huntington's chorea)
- accumulation of toxic metabolites or reduced ability of the organism to compensate for damage

## **EXPRESSIVITY OF THE GIVEN FORM**

*hereditary traits manifest themselves unequally in individuals of a given genotype, we speak of different expressivity*

- expressivity is an extend of the expression of a given genotype in the phenotype of an individual
- depends on many factors (other genes (modifying genes), environmental factors, etc.)
- for allele carriers e.g. for polydactyly there are various morphological deviations (from skin algae to fully functional extra fingers)

## Application of Mendel's laws in medicine – monogenic inheritance

The experimental results of Mendel's experiments have implications for the human medicine  
They are the basis of the inheritance of monogenic diseases

However, monitoring inherited patterns in humans presents a number of difficulties

- **for ethical reasons**, the basic method of experimental genetics, hybridization experiment, cannot be performed
- **people are long-living**, the age of the observed individual is approximately as long as the age of the observer, for this reason it is usually possible to observe directly in families only 3 generations
- the number of offspring in one family is genetically low
- for these reasons, **genealogy** is used in human genetics as a basic method
  - Genealogy (pedigree science) can be used both to understand the genetic laws of transmission of a certain trait, and for practical applications in the field of consulting and genetic counseling

# Application of Mendel's laws in medicine – genealogical method

The person who led to the choice of family is referred to as the **proband**

- the proband can be both an affected patient and an individual from a family with a possible hereditary disease

**Family history is consulted in a genetic counseling center with a clinical geneticist**

Data are recorded graphically in the form of genealogical scheme (pedigree) and supplemented by a so-called legend

## Genealogy chart (pedigree)

- **standardized symbols** are used to compose the pedigrees
- it is possible to graphically capture one, at most a few traits, in order not to violate the clarity of this method
- the obtained genealogical material is subjected to analysis
- in case the observed trait occurs rarely in the population (most monogenic inherited diseases), genealogical schemes usually take the form of a typical pedigree

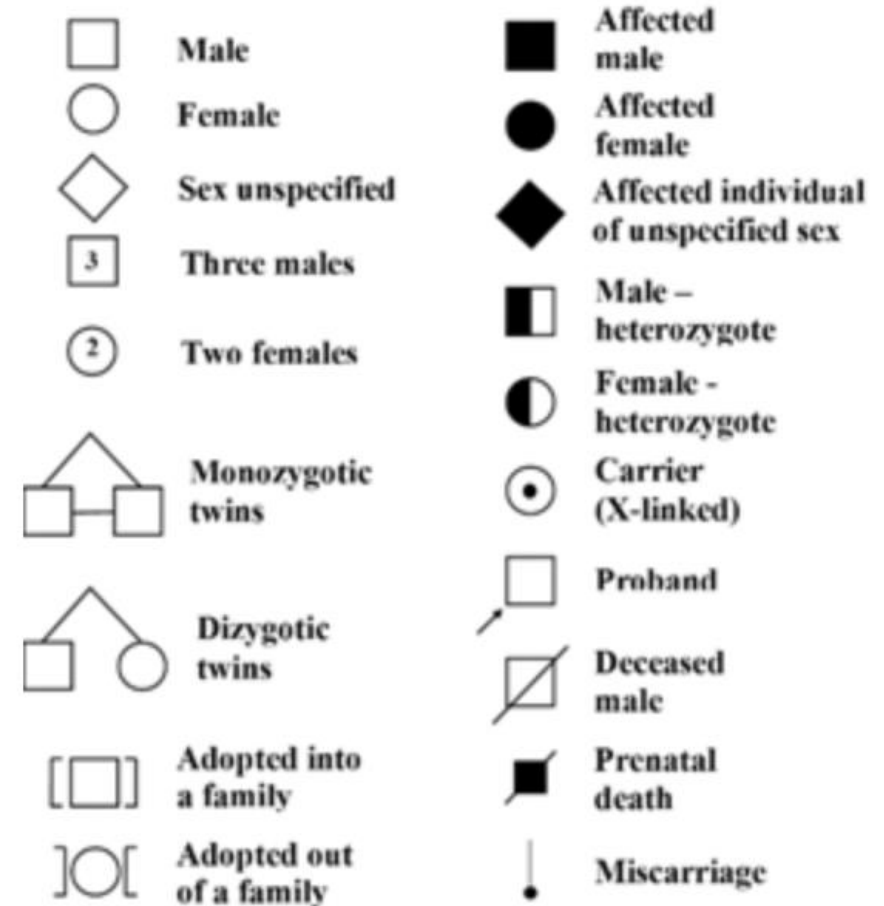

## Application of Mendel's laws in medicine – monogenic inheritance

**Monogenic diseases are the results of mutations.** The effects of the environmental factors on the development of these diseases is usually minimal. The **OMIM** (Online Mendelian Inheritance in Man) database currently contains tens of thousands of well described monogenic diseases.

The type of monogenic inheritance is determined mainly by two factors:

1. Chromosomal location of a gene locus, which may be **autosomal** (= lying on one of the autosomes - asexual chromosome) or **gonosomal** X-linked (lying on the sex chromosome X)
2. Whether the phenotype is **dominant** (manifests itself if only one chromosome in the pair carries the mutant allele, although the allele on the other chromosome is normal); or **recessive** (manifests only when both chromosomes of the pair carry a mutant allele).

4 basic types of inheritance

**autosomal dominant / autosomal recessive / X-linked dominant / X-linked recessive**

# Application of Mendel's laws in medicine – autosomal recessive (AR) inheritance

Affected individual - **recessive homozygote (aa)**  
 Parents of the disabled person **heterozygotes (Aa)**

Risk of disease  
 - probability **1/4** for siblings of a sick individual

The probability of a heterozygous condition for healthy siblings of a sick individual is **2/3**

Men and women - the same probability of disease

**Consanguineous marriages**  
 - occurrence of rare AR diseases

**All progeny of a sick individual are carriers of a mutated (recessive) allele**

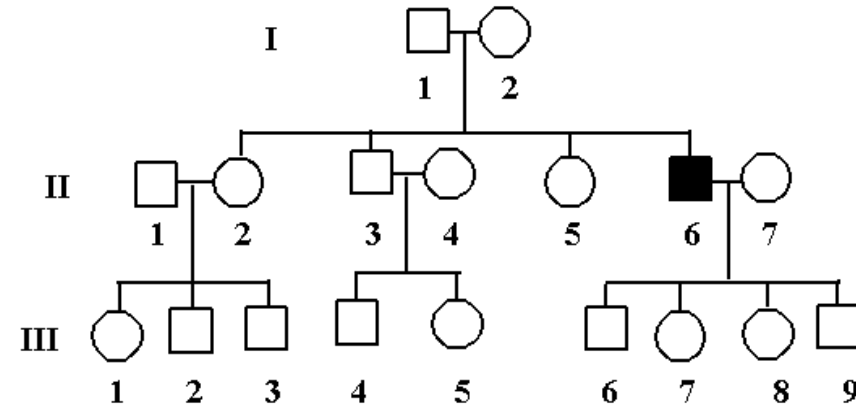

Parents **Aa x Aa**



Progeny

**genotype ratio**

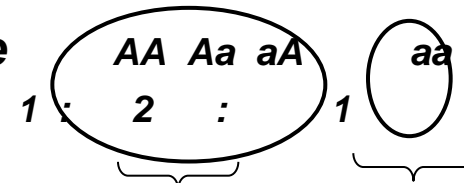

Healthy offspring **3/4**      Affected **1/4**



1/3 AA; **2/3 Aa**



# Application of Mendel's laws in medicine – autosomal recessive (AR) inheritance

## Autosomal recessive inheritance - example / result

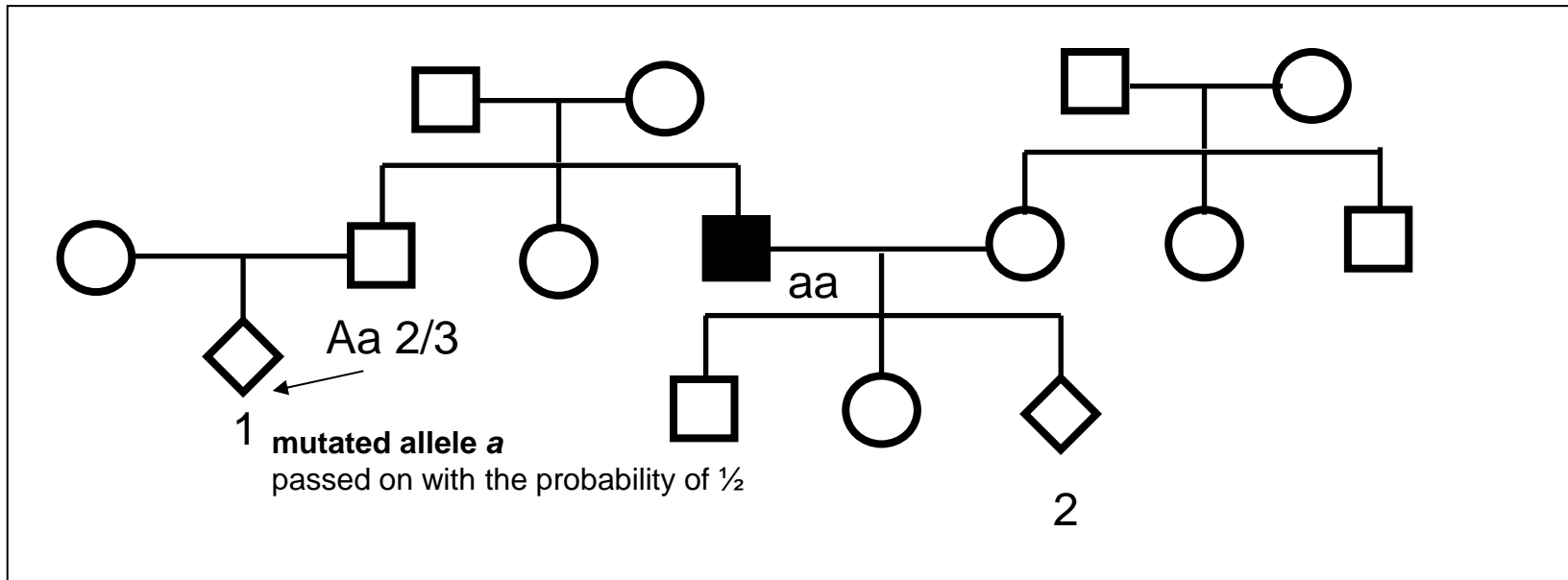

Determine the probability of disability of fetuses 1 and 2

- 1 - disability 0; heterozygous - probability  $\frac{1}{3}$  ( $\frac{2}{3} \times \frac{1}{2}$ )
- 2 - disability 0; heterozygous 100%

## Application of Mendel's laws in medicine – autosomal recessive (AR) inheritance

AR inherited diseases occur with a lower frequency than autosomal dominant diseases. Most AR diseases **arise on the basis of a relationship between two random carriers**, in particular if the frequency of the recessive trait is high in the population, such as cystic fibrosis.

### **CYSTIC FIBROSIS**

Incidence 1: 2500

Mutations in the CFTR (cystic fibrosis transmembrane conductance regulator) gene - regulation of the function of ion channels of the epithelial cell membrane  
transmembrane transfer of chloride ions (Cl<sup>-</sup>) increased concentration of Na<sup>+</sup> and Cl<sup>-</sup> in sweat

Most affected: **lungs** - recurrent lung infections, **pancreas** - lack of pancreatic enzymes

Death usually around 35 years of age (historically), currently thanks to the new drugs, in USA and EU is life expectancy 45-50 years

# MECHANISM OF ACTION

Targeting *F508del*-CFTR brings more active CFTR proteins to the cell surface<sup>1</sup>

## DEFECTIVE *F508del*-CFTR PROTEIN

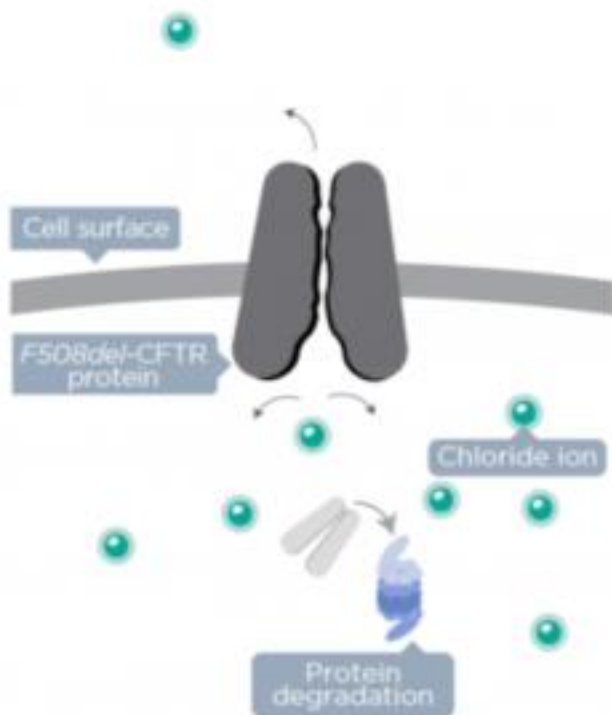

- Patients with an *F508del*-CFTR mutation have decreased CFTR activity at the cell surface<sup>2</sup>

## TEZACAFTOR and IVACAFTOR

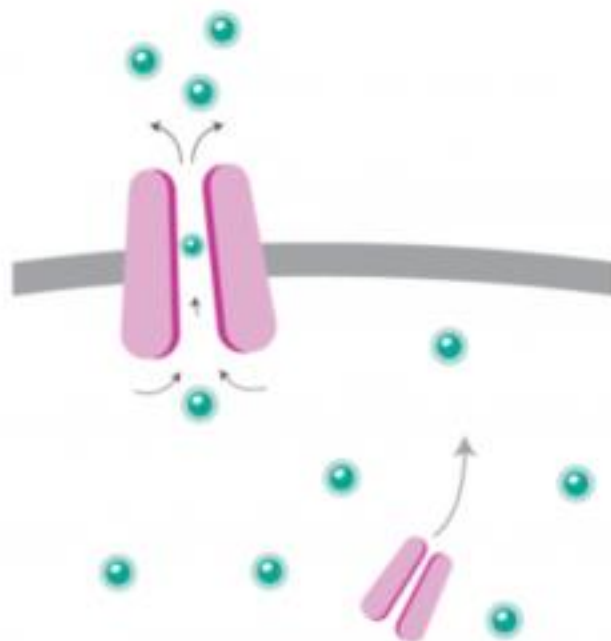

- Tezacaftor improves cellular processing and trafficking of *F508del*-CFTR proteins<sup>1</sup>
- Ivacaftor potentiates the channel-open probability of CFTR proteins at the cell surface<sup>1</sup>

## ELEXACAFTOR, TEZACAFTOR, and IVACAFTOR

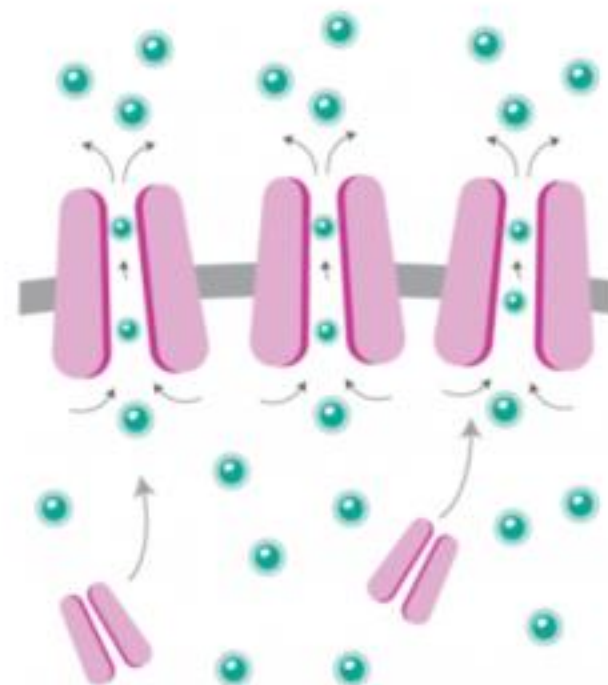

- Binding to a different site than tezacaftor, elexacaftor has an additive effect in improving cellular processing and trafficking of *F508del*-CFTR proteins<sup>1</sup>

## Application of Mendel's laws in medicine – autosomal recessive (AR) inheritance

### PHENYLKETONURIA (PKU)

Incidence 1: 10,000

metabolic disease caused by a mutation in the gene for the liver enzyme

### phenylalanine hydroxylase (PAH)

inability to digest the amino acid phenylalanine (convert phenylalanine to tyrosine) - accumulation of phenylalanine in the body - **convulsions, liver failure, brain damage**

strict low-phenylalanin diet required

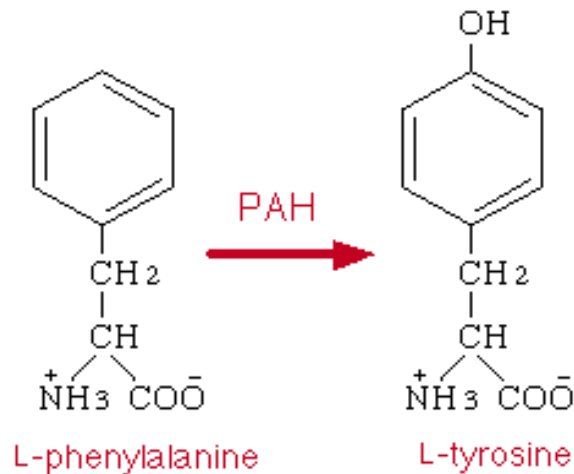

### EXAMPLES OF OTHER AR DISEASES

Sickle cell disease

Galactosemia

Tay-Sachs disease

Thalassemia

# PHENYLKETONURIA = PKU

Autosomal recessive phenylalanine hydroxylase deficiency = PAH

Neonatal screening performed on day 3 showed a high level of Phe 734  $\mu\text{mol/l}$  in the newborn boy (norm  $<120$ ). PKU was suspected and the child was hospitalized on day 8. Control samples confirmed a high Phe value. The diagnosis of the classical form of PKU was also confirmed at the molecular level. A prevalent c.1222C>T mutation was detected; p.Arg408Trp in the PAH gene in a homozygous state.

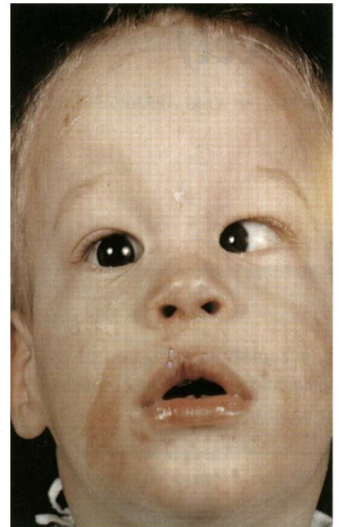
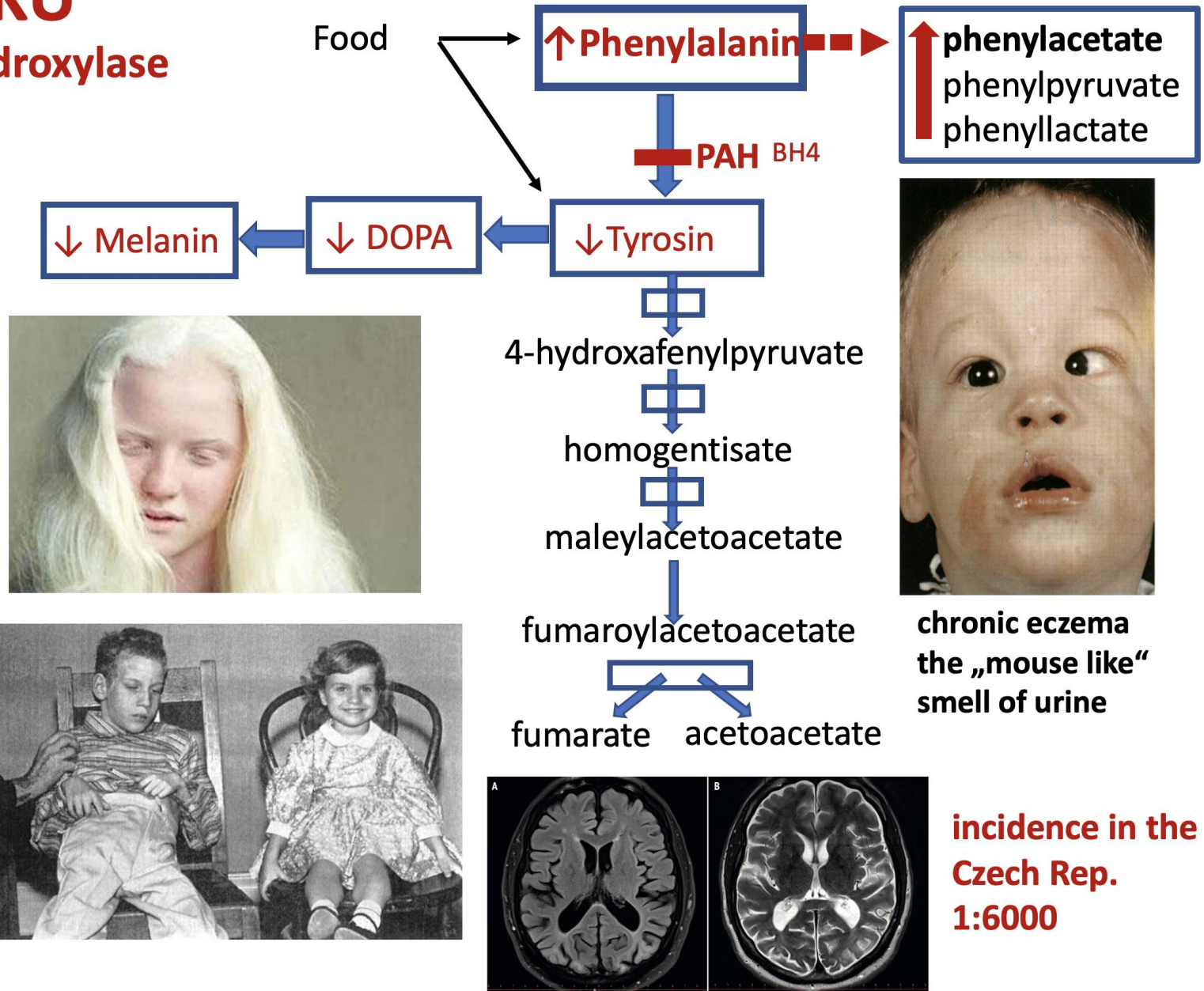

# Application of Mendel's laws in medicine – autosomal dominant (AD) inheritance

A sick individual has a one of the parents diseased (with exception of rare *de novo* mutation)

One mutated allele → disease

Risk of disease for each offspring of a sick parent → 50%

Men and women - the same risk of disease

Healthy offspring of a sick parent do not pass on the mutation to their offspring

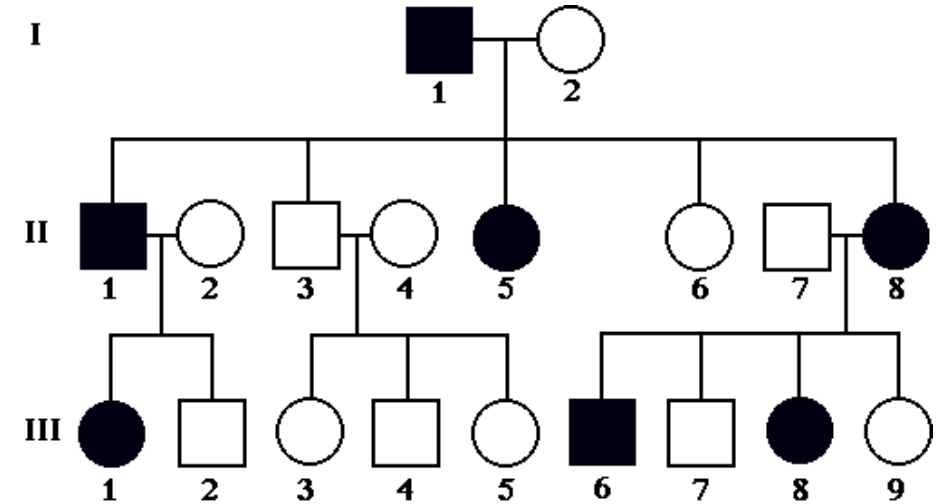

# Application of Mendel's laws in medicine – autosomal dominant (AD) inheritance

Write the genotypes of the pedigree members (assuming the father is heterozygous)

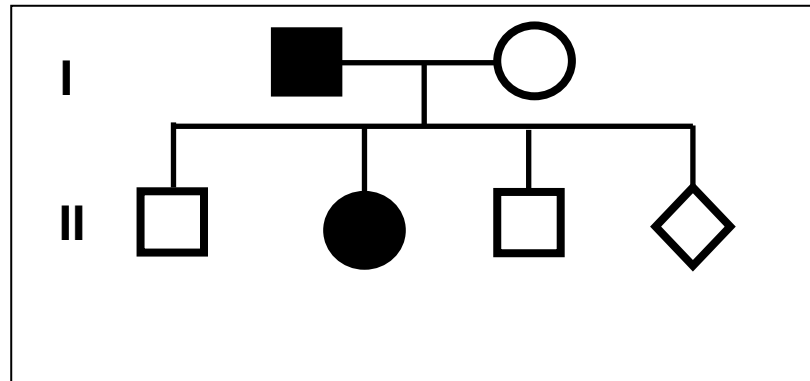

I/1 Aa  
I/2 aa  
II/1 aa  
II/2 Aa  
II/3 aa  
II/4 Aa (50%), aa (50%)

	a	a
A	Aa	Aa
a	aa	aa

A- mutated allele

# Application of Mendel's laws in medicine – autosomal dominant (AD) inheritance

## POLYCYSTIC KIDNEY DISEASE

Incidence: 1/600 -1/1000

**Polycystic kidney disease is the most common AD disease.** It leads to cysts in the kidneys, liver, pancreas and spleen. Cysts in the kidney are usually asymptomatic until renal failure or the onset of hypertension (usually in the fourth decade of life).

## Mutations in the PKD1 or PKD2 gene (encodes the polycystin protein)

By adulthood mild or no symptoms

1/3 of patients - cysts in the liver

10% of patients have dilated veins in the brain → stroke

Therapy: ABX frequent infections, regulate blood pressure, dialysis, kidney transplantation.



# Application of Mendel's laws in medicine – autosomal dominant (AD) inheritance

## HUNTINGTON'S DISEASE

**Incidence** is 1 / 10,000–20,000 individuals.

Huntington's chorea is a neurodegenerative disease.

It is characterized by ineffective (involuntary) movements and progressive dementia.

The onset of the disease is variable.

A mutation in the gene that encodes the protein **huntingtin** manifests as an **expansion of triplet nucleotide 5'-CAG-3'** at the 5' end of the first exon of the gene

10 - 34 repeats 5'-CAG-3' (in healthy individuals)

Patients with severe disabilities **42 - 100 5'-CAG-3' repeats**

If the symptoms appear in childhood, more than 60 repeats are usually present in the gene.

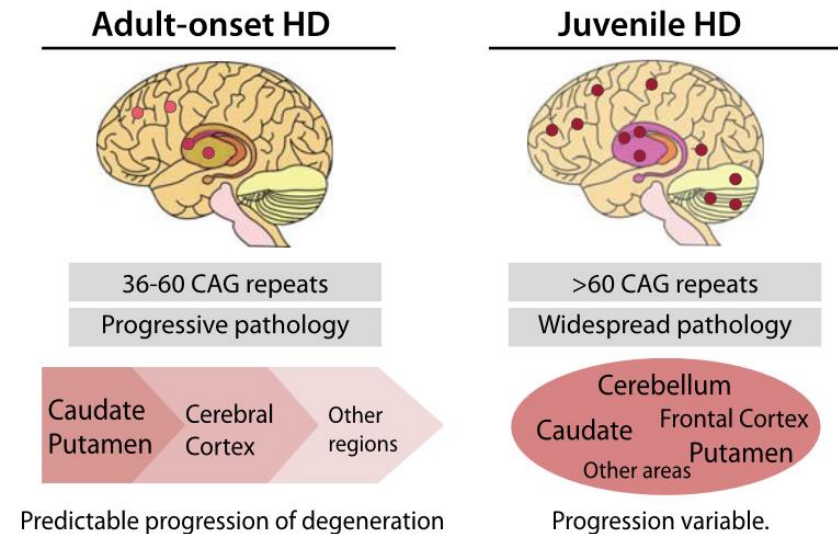

# Application of Mendel's laws in medicine – autosomal dominant (AD) inheritance

## ACHONDROPLASIA

**Point mutation** (nucleotide change) in the **FGFR 3** (fibroblast growth factor receptor) gene

**Short limbs** → during embryonic development and in childhood the bones of the limbs grow more slowly; body size is average

Difficulty in children: speech, hearing, breathing



### EXAMPLES OF OTHER AD DISEASES

Brachydactyly

Hypercholesterolemia

Neurofibromatosis

Marfan's syndrome

## Case report - Marfan's syndrome



28 years old male, 172 cm tall, 40 kg

Two siblings died shortly after birth

Confirmed mutation in FBN1 gene (fibrillin 1)

FBN1 - c.1426T> G (p.Cys476Gly) as causal for MFS.

Pectus excavatum (inverted chest)

Wrist impairment, arachnodactyly (spider fingers)

Severe sole (foot) damage pes planus planus (talipes calcaneovalgus)

Pain in the back and abdomen in the epigastrium area.

-> Aneurysm of the ascending aorta

Surgery -> Thoracoabdominal aortic replacement



### Marfan's syndrome (fibrillin)

- genetic disorder of connective tissue
- symptoms: tall figure, long thin limbs, long thin fingers (arachnodactyly), ocular lens dislocation (ectopia lentis) and cardiovascular abnormalities
- inherited autosomal dominant disease
- frequency approximately 1: 10000 (Niccolò Paganini, Abraham Lincoln)

# Application of Mendel's laws in medicine – autosomal dominant (AD) inheritance

## POLYDACTYLY

- non-functional transcription factor Gli3 regulating the production of proteins involved in determining the anteroposterior polarity of developing limbs
- excessive number of fingers and toes

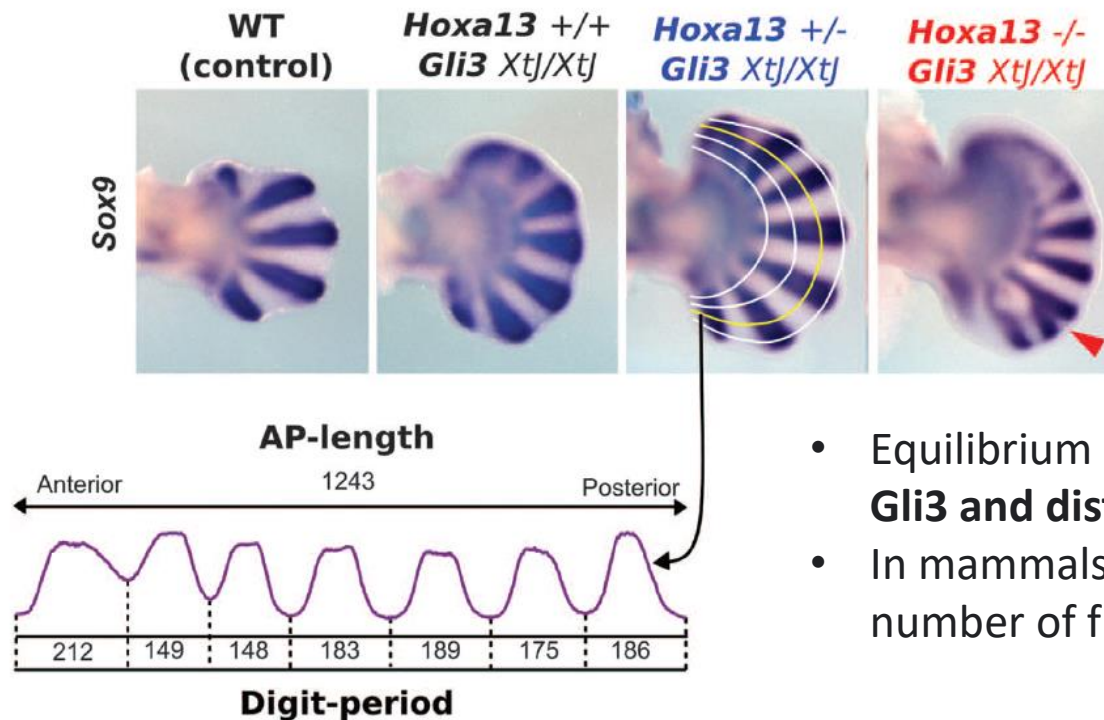

- Equilibrium created by mutual regulation between **Shh**, **Gli3** and distal **Hox** genes
- In mammals, it probably leads to a stabilization of the number of fingers at 5

# Application of Mendel's laws in medicine – autosomal dominant (AD) inheritance

- in some cases, the mutated allele will only affect some carriers
- the same allele usually manifests itself to varying degrees in different carriers  
**due to the influence of other modifying genes and the environment**

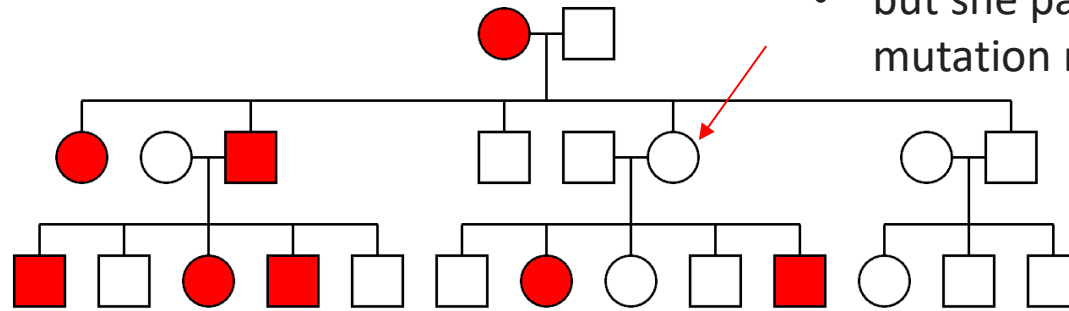

Polydactyly - pedigree

- the woman carries the mutated allele without manifestation (she has a normal number of fingers)
- but she passed it on to her offspring, in whom the mutation manifested itself again (incomplete **penetrance**)

- In addition, expression of the phenotype may not always be the same (one extra growth versus three extra equivalent fingers) (different **expressivity**)



# Gonosomal recessive (GR) inheritance

There is no transfer from father to son

Men are affected more often than women  
(one X chromosome)

Diseased son - a mutated allele from the mother

Sons of heterozygous mothers

- 50% risk of gaining a mutated allele

Daughters of a heterozygous mother

- carriers - risk 50%

Daughters of disabled men - 100% carrier

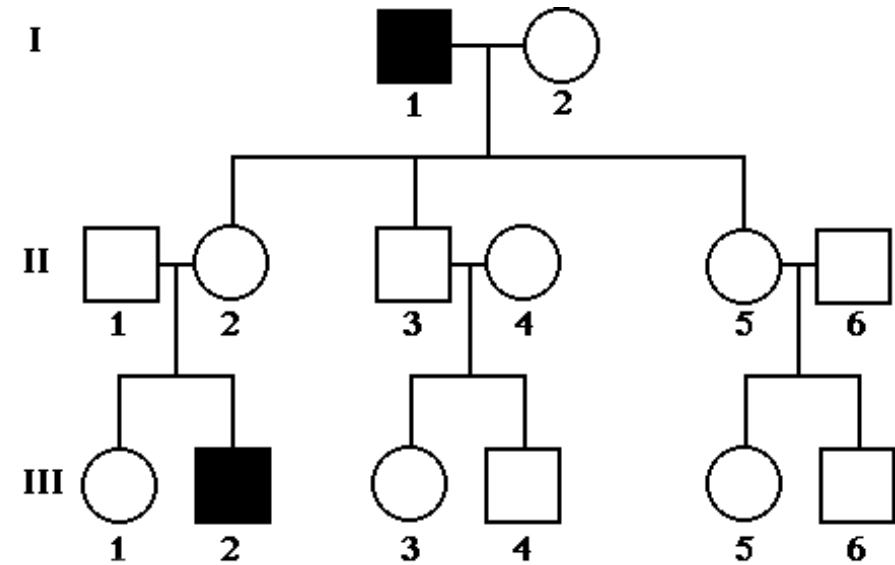

a typical pedigree of GR

- characteristic with **skipping of one generation**, ie. that the disabled man has all the daughters - carriers (healthy heterozygotes) and all the sons are healthy (they get Y from the father)

## Gonosomal recessive (GR) inheritance

This is, in principle, a **deviation from Mendel's laws of inheritance**

the gene of interest is not located on the autosome, but on the gonosome

Men are **hemizygotes** for these genes and in the case of recessive genes they then show so called **pseudodominance**

- **pseudodominance is a phenotypic manifestation of one recessive allele**, which is caused by the fact that the allele does not have a corresponding locus on the other heterochromosome

# Gonosomal recessive (GR) inheritance

## HEMOPHILIA

**Hemophilia A** 1/10000 affected men - mutations in the gene for the production of coagulation factor VIII

**Hemophilia B** - mutation of the coagulation factor IX gene

### Queen Victoria of England (carrier of hemophilia) and her descendants

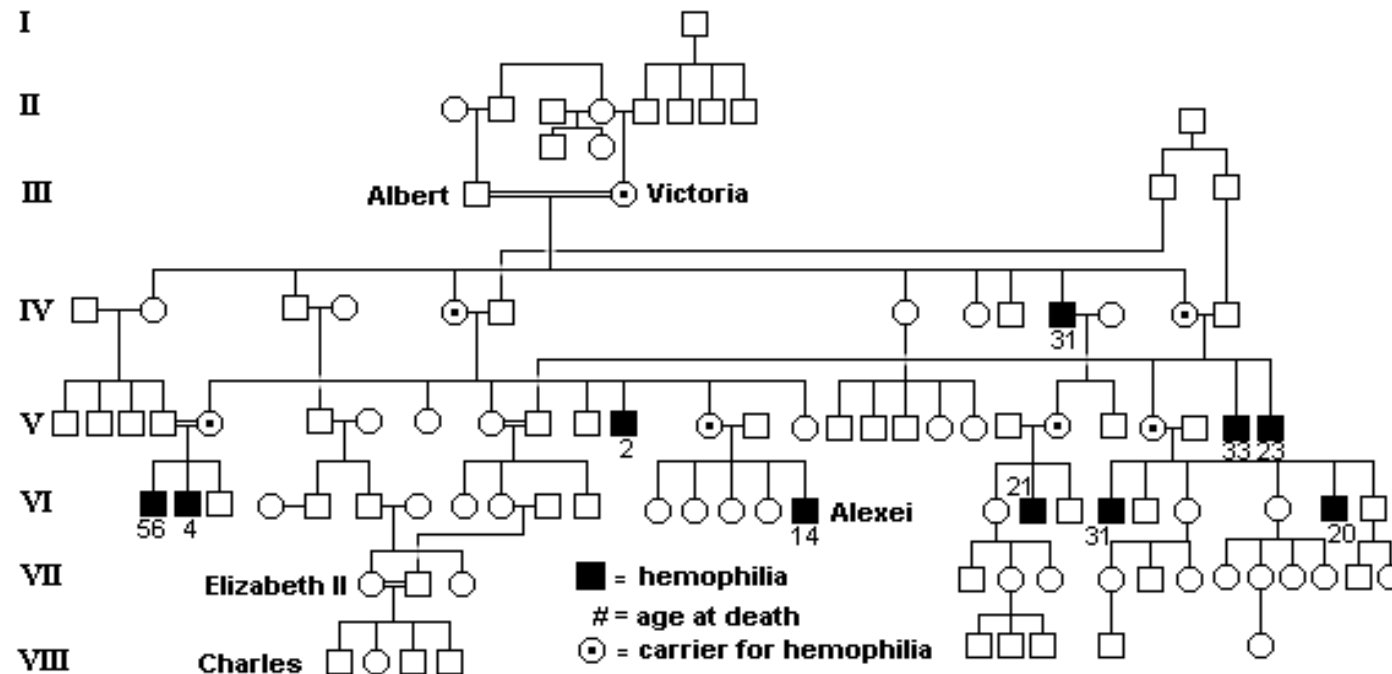



## Gonosomal recessive (GR) inheritance

### DUCHENN'S MUSCULAR DYSTROPHY (DMS)

The incidence of DMS is 1/3000 of boys born.

DMS is caused by a mutation in the gene encoding the **dystrophin** protein, which affects the function of all muscle types.

The onset of the disease is in childhood.

The first symptom is swaying when walking, difficulty walking up the stairs, progressive weakness. Around 10 years, the affected individuals become immobile.

**Muscle weakness gradually continues, death occurs around the age of 20** due to heart and respiratory failure.

Although boys die before they reach reproductive age, the **recessive allele in the population is maintained in the genome of healthy heterozygous women.**

One third of the affected boys **developed a *de novo* mutation in the dystrophin gene.** The gene encoding dystrophin is large and has a higher frequency of spontaneous mutations.

### DALTONISM

One of the congenital causes of color blindness. Affected people lack or have limited ability to distinguish between red and green.

# Gonosomal dominant (GD) inheritance

The transmission of the mutation is **not from father to son**  
**Affected men** pass on the mutated allele to all **daughters**

Female heterozygous → offspring of mutated allele with 50% probability

Men → disabilities with a greater extent (also lethal) - (pseudodominance - presence of only one X chromosome)

**Women are more likely to have GD disease**  
→ they can get the mutated allele from both the affected father and the affected mother

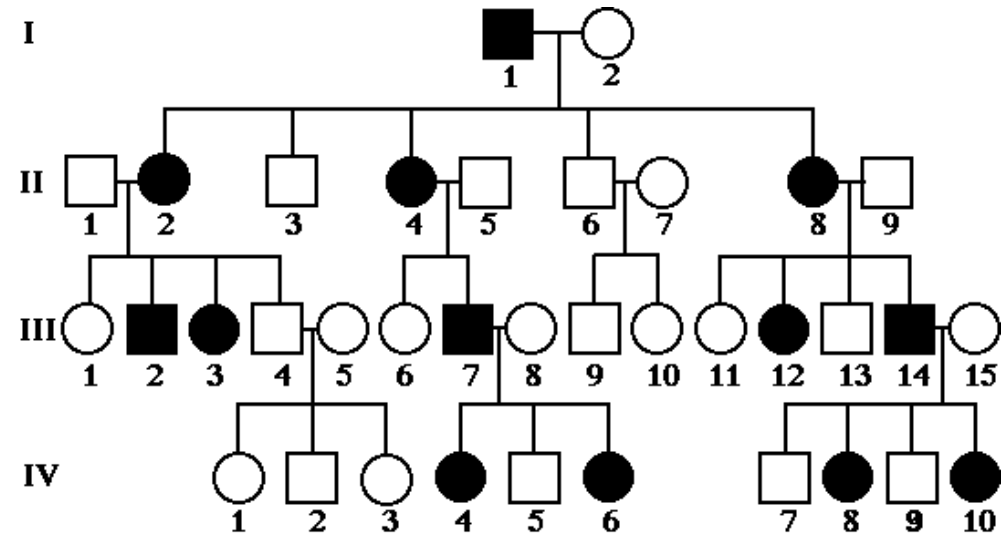

GD diseases:

**hypophosphatemic rickets**  
**(vitamin D-resistant rickets)**

This dominant inherited form of rickets occurs even with sufficient vitamin D intake. The usual intake of vitamin D does not improve the condition of patients.

## Mitochondrial inheritance

**Mitochondrial genetic diseases** are caused by mutations in mitochondrial DNA (mtDNA) and are inherited only through the mother (**matrocline inheritance**).

- **only oocyte mitochondria are preserved after fertilization of the egg.** This is probably not only a consequence of the much higher number of mitochondria in the oocyte (100,000) than in the sperm (50-70), but a consequence of the active process of elimination of paternal mitochondria after fertilization.
- due to the large number of mitochondria in one cell, the mutation is often present in only part of the mitochondria - so-called **heteroplasmy**, if the heteroplasmic mutation is inherited or occurs during the early period of embryogenesis, normal and mutated variants are randomly transmitted during cell division to daughter cells.

Most such mutations are associated with **impaired energy production in mitochondria**, so these mutations are manifested mainly by disorders of energy-dependent organs such as the nervous system or visual system (encephalopathy, ataxia, spasticity, cardiomyopathy, deafness or diabetes mellitus).

They usually have a later onset (only in adulthood).

**Not all diseases caused by mitochondrial dysfunction are caused by this inheritance - some proteins are encoded by mtDNA, other by nuclear DNA!**

**Leber's optic atrophy:** It is a disease with onset in early adulthood and manifests itself in rapid, progressive and bilateral loss of vision and subsequent blindness.

Atrophy of the optic nerve (optic nerve) occurs. The disease is more common in boys.

# Numerical chromosome aberrations

**They arise mainly as a consequence of errors in nuclear division**

Changes in the number of chromosomes in a cell.

Organisms that contain more than two sets of chromosomes

- **POLYPLOIDY** (triploid, tetraploid, hexaploid, octaploid, etc. cells).

In animals, this condition is **incompatible with life**.

Only some placental cells are triploid.

In plants, on the other hand, polyploidy is accompanied by greater vitality - higher stature, larger fruits, etc.

The change in the number of chromosomes is called **ANEUPLOIDIA**.

The whole set does not multiply, but a specific **chromosome is extra or is missing**.

**incorrect gene dosage** → and therefore also incorrect dose of their products (proteins / RNA)

genes contained on each chromosome encode various regulatory proteins important for the development of the organism and the maintenance of homeostasis (transcription factors, signals, receptors, cell cycle regulators ...)

- their incorrect dose causes the failure of various regulatory processes

- numerical aberrations usually lead to serious problems already during embryonic development - abortions or developmental defects

## Causes of numerical aberrations

Unequal distribution of chromosomes (**non-disjunction**)

- **during meiosis - numerical aberrations in gametes** - by dividing the zygote it spreads to the whole resulting individual
- **during mitosis - numerical aberrations in somatic cells**
  - by division it spreads to a part of the cells of the organism
  - contributes to the development of cancer or leads **to milder forms of developmental syndromes** (less severe symptoms than if aneuploidy is present in all somatic cells)



Only some cells in the body will be aneuploid (**chromosomal mosaicism**). The sooner nondisjunction occurs during embryogenesis, the more cells will be aneuploid.

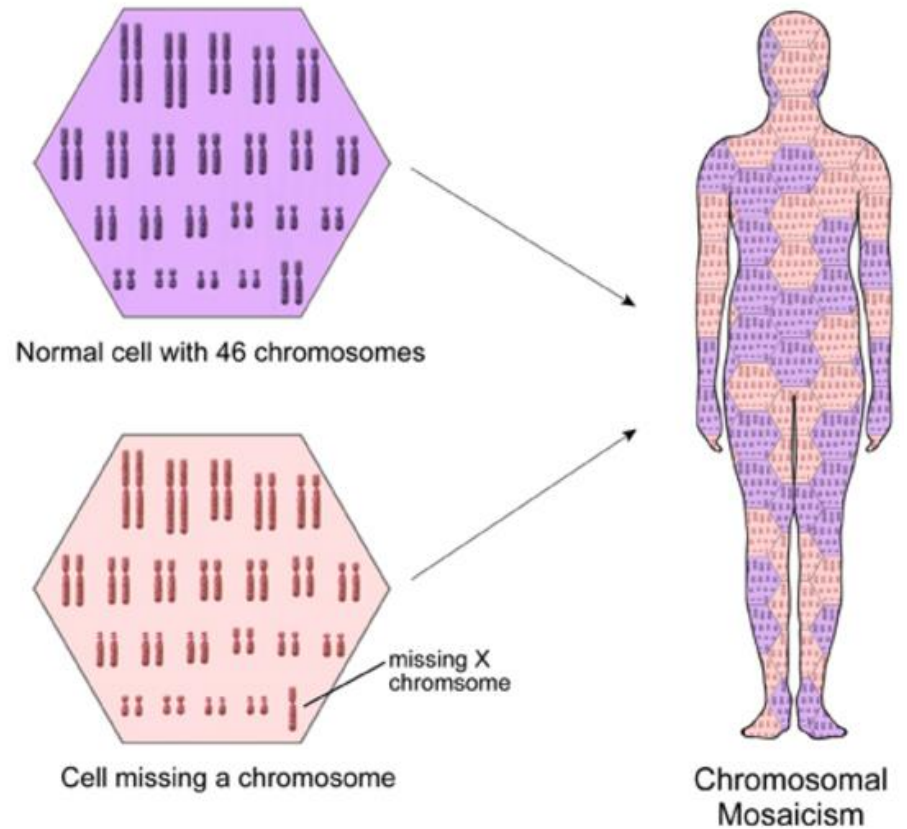

## Human monosomy

The absence of a chromosome with the all respective genes is usually critical  
- the **human embryos fail to develop successfully, will die**

The only exception is the lack of one copy of the X chromosome in women  
(**Turner syndrome**)

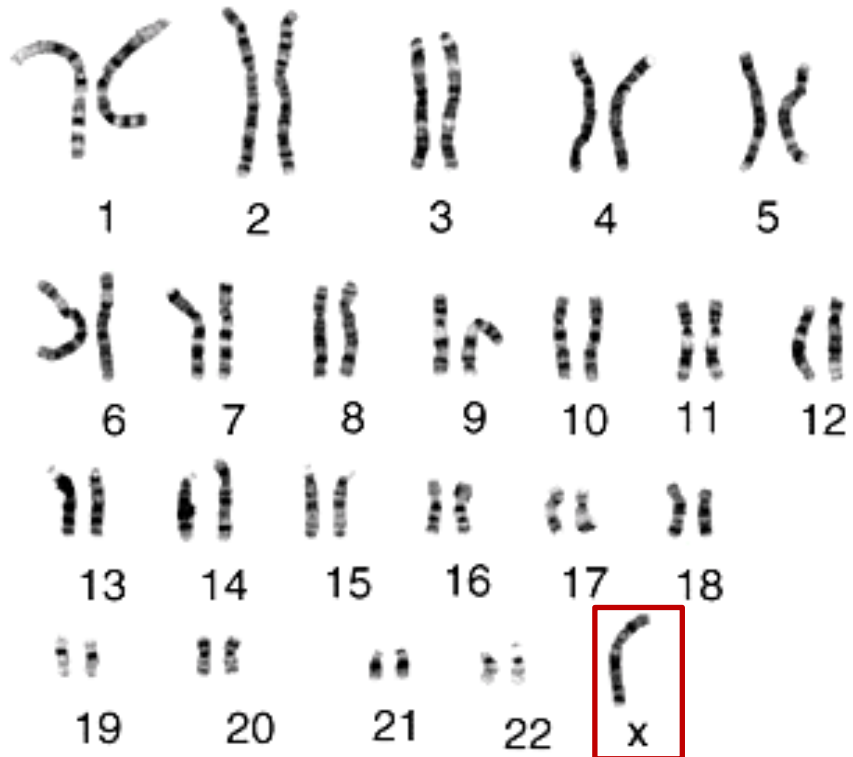

### Exceptions?

- two copies of the X chromosome are necessary during embryonic development to initiate the development of female reproductive organs

# Turner syndrome, 45,X0

1 in 5000 females are born with it

ovaries do not develop properly → **sterility** (possibility to have a child from a donated egg after in vitro fertilization)

without **hormonal therapy with estrogen** there is no development of secondary sexual characteristics – estrogen is also used to prevent osteoporosis

reduced sensitivity to growth hormone **somatotropin** → without somatotropin treatment they have a short height (approx. 140 - 160 cm)

more common cardiovascular problems



wide neck with fold of skin

## X chromosome inactivation

- extra copy of the X chromosome is **inactivated** in women - one of the X chromosomes condenses and its genes are not transcribed → **Barr's body**
- inactivation occurs during embryogenesis



- one of two X chromosomes is accidentally inactivated in each embryonic cell
- inactivation is passed on to all cells originated by mitosis from original cell

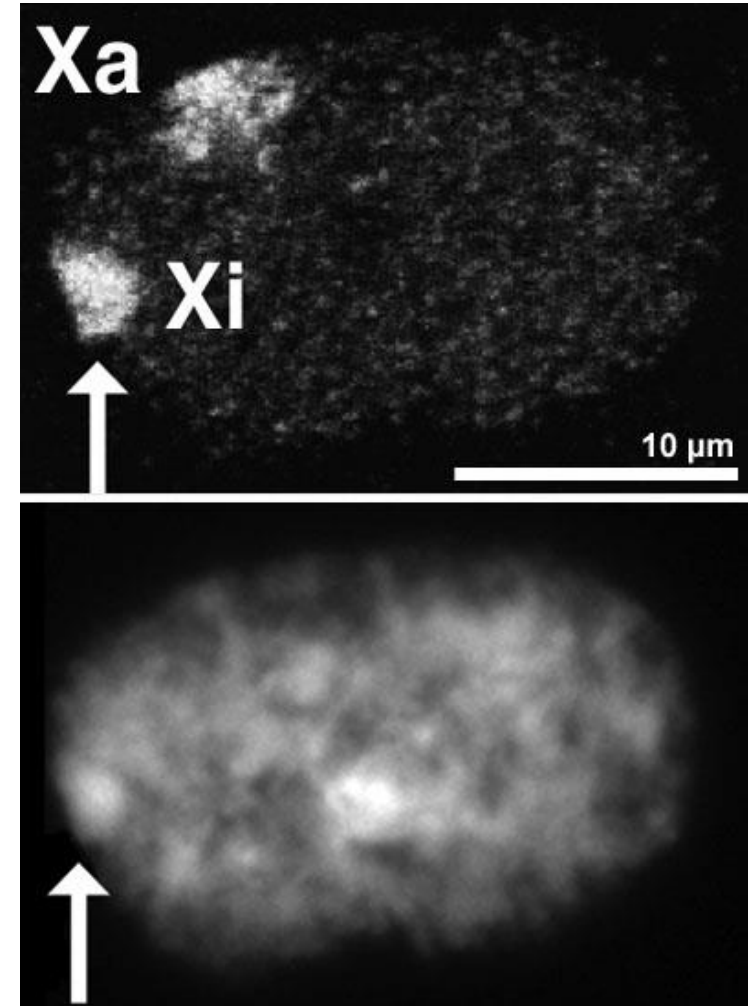



## Trisomy in humans

- chromosome redundancy with all contained genes is usually critically harmful
- overdose of some proteins leads to deregulation of regulatory processes in the human body
- the human embryo **usually fail to develop successfully** and die

### Exceptions?

- A few exceptions present redundant gonosomes and some relatively short autosomes
  - **Down syndrome (21), Edwards syndrome (18), Patau syndrome (13)**
  - **Klinefelter's syndrome XXY, syndrome XXX, syndrome XYY**
  - but even in these syndromes abortions often occur and only a small part of the embryos is born

The symptoms depend on which **proteins** are encoded by the genes on a given chromosome and which are therefore in excess - what signaling pathways are overactive in the developing embryo and what developmental processes are thus disrupted.

# Trisomy 21



Down syndrome

# Down syndrome

## TRISOMY 21

1 in 700 to 800 live births,  
**heart development disorders, slower growth, slower mental development,** slower motor development, weaker muscle tone, need for physiotherapy, increased risk of leukemia, average life expectancy with modern treatment is 60 years

**Aneuploidy** may occur during **meiosis** (nondisjunction - incorrect separation of chromosomes or chromatids to cell poles) or during **mitotic division**. **Meiotic nondisjunction affects all cells of the body**. The error in the separation of chromatids to cell poles during **mitotic division** leads to the formation of clones of aneuploid cells - **mosaicism**.

For example, if mitotic nondisjunction of chromosome 21 occurs in the early postzygotic period, **Down's syndrome develops with a range of clinical symptoms that correspond to the ratio of cells with normal karyotype and trisomy** - eg  $\text{mos}46, \text{XY} [10] / 47, \text{XY}, + 21 [25]$ . The number in square brackets indicates the number of cells with particular karyotype in the examined sample.

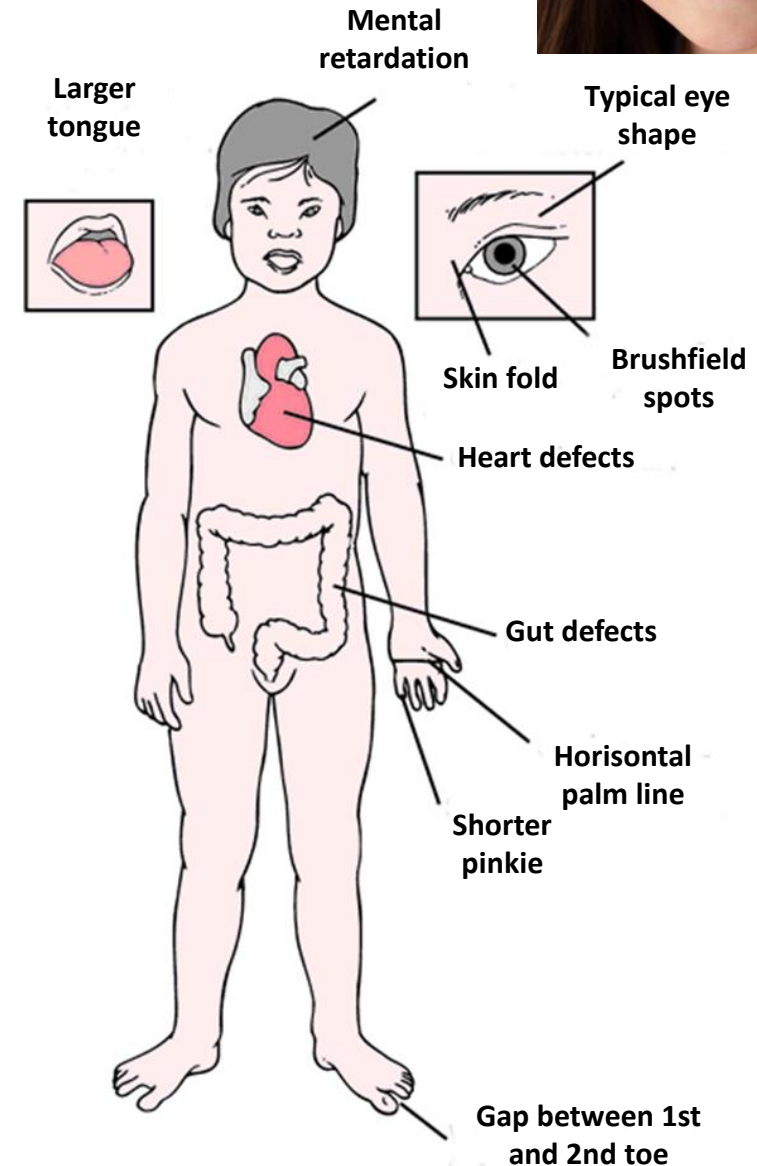

# Edwards syndrome

## TRISOMY 18

- 1 in 6,000 to 7,000 live births (over 50% of pregnancies end in miscarriage)
- severe developmental disorders
  - congenital malformations of the heart, lungs, digestive and urogenital tract
  - frequent clefts of the lip or palate
- average life expectancy in the order of months (only 5% of children live to be 1 year old)



# Patau syndroms

## TRISOMY 13

- 1 in 14,000 or more live births
- **very severe developmental disorders**
  - congenital malformations of the heart, central nervous system, lungs, urogenital tract, polycystic kidneys
  - **frequent facial clefts** and polydactyly
  - deafness, damage to eyesight
- average life expectancy in the order of weeks (only 5-10% of children live to be 1 year old)



# Klinefelter syndrome

## TRISOMY OF GONOSOMES - XXY

1 in 500 to 1000 people

- usually male, but sometimes slightly feminized phenotype or intersex without **testosterone replacement therapy**
- sometimes there is no proper testicular development and testosterone production → **fertility disorders** (for some patients the possibility of having a child due to surgical collection of sperm)
- sometimes delayed motor development - need for physiotherapy
- usually taller



# Trisomy X

## TRISOMY OF CHROMOSOME X

- 1 in 1,000 women (estimate)
- often taller
- usually slightly delayed development and development of speech, but some patients without problems
- sometimes weaker muscle tone or scoliosis - the need for physiotherapy
- many women with karyotype XXX do not know about their X chromosome at all

# XYY syndrome ("supermale")

## TRISOMY OF GONOSOMES – XYY

- 1 in 1,000 men (estimate)
- high stature
- standard testosterone production, normal fertility, healthy offspring → most men with karyotype XYY do not know about their Y chromosome at all

<http://www.triple-x-syndroom.nl/stories>

[www.triple-x-syndroom.nl/document69/diagnoses\\_triplex\\_what\\_can\\_be\\_expected](http://www.triple-x-syndroom.nl/document69/diagnoses_triplex_what_can_be_expected)

# Structural aberrations of chromosomes

- changes in chromosome structure
- the DNA sequence of the affected chromosomes changes:
  - **part of the chromosome may be deleted or amplified**
    - the number of copies of genes located in a given (missing or redundant) region changes
    - **incorrect gene doses** of these genes and their products
    - changes in large regions of DNA containing many genes usually lead to **miscarriages or developmental defects**
    - chromosome rearrangements can also lead to the development of cancer
  - **or part of a chromosome is translocated** (to another chromosome)
    - near a strong promoter can lead to altered gene expression
    - or the joining of two genes and the formation of a fusion product with an undesired function
- may occur during sperm and oocyte development, during early fetal development, or during later life in any cell
- **the effect depends on the size and location** of the structural reconstruction



# Structural aberrations of chromosomes

**Deletion**

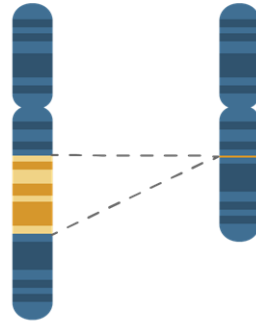

**Duplication**

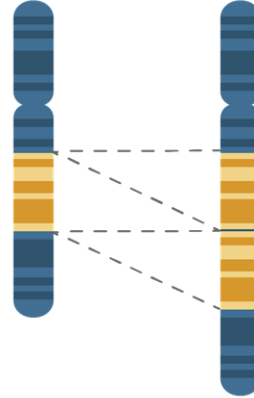

**Inversion**

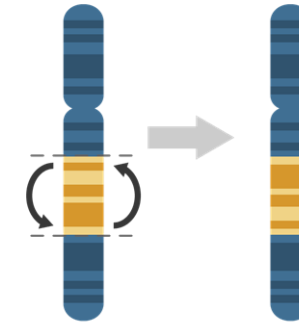

**Reciprocal translocation**

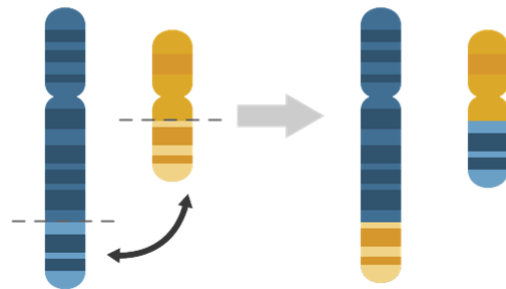

**Robertson translocation  
(fusion of two acrocentric  
chromosomes)**

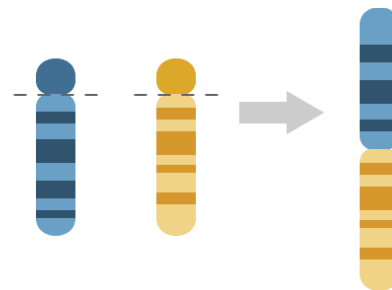

**Ring chromosome**

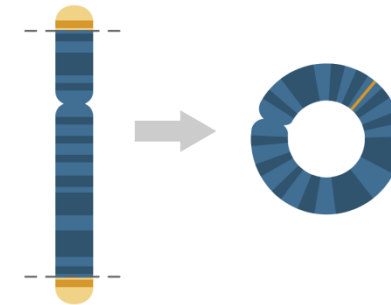

# Causes of structural aberrations

- **incorrect chromosome pairing / crossing-over** during meiosis and subsequent gamete formation with incorrect structure of some chromosomes
  - deletion, duplication (in case of incorrect pairing of homologous chromosomes)
  - translocation (in case of incorrect pairing of non-homologous chromosomes)

—————> whole embryo is impacted

- **DNA breaks and their incorrect repair** - deletions, duplications, translocations, inversions, ring chromosomes ...

—————> impact depending on whether the break occurs in gametes or in somatic cells

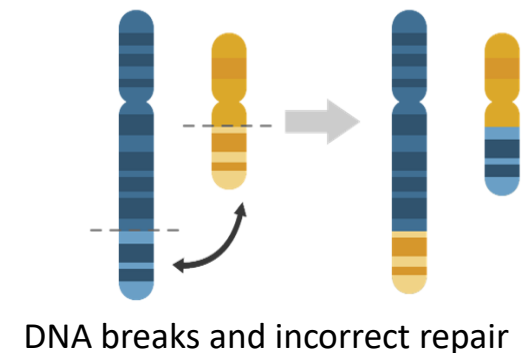
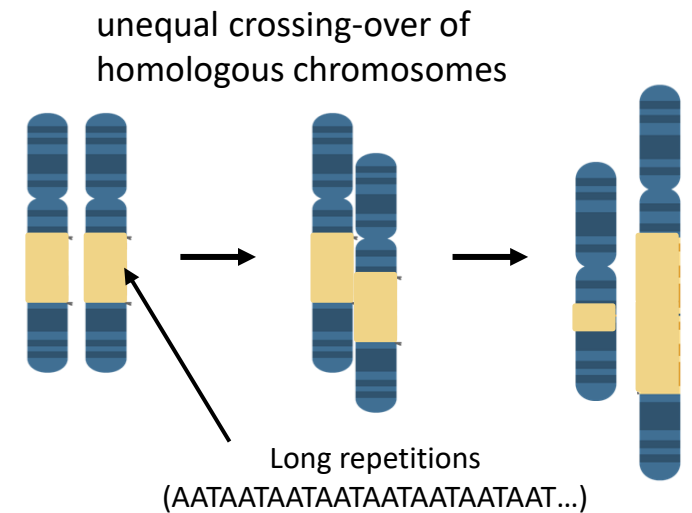

## Deletions

part of the chromosome is missing

- the more genes are missing, and the more important the genes, the more severe the consequences
- usually disorders of development or cell division

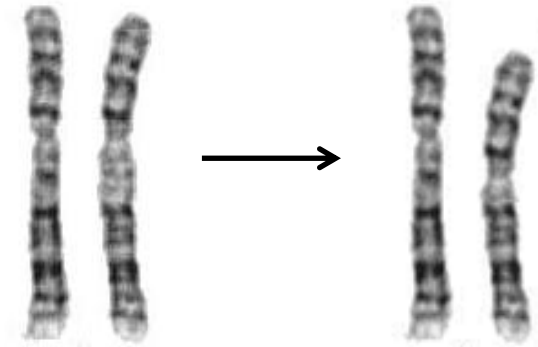

### DiGeorge syndrome

- a small part of chromosome 22 is deleted
- 1 in 2000-4000 live births
- symptoms:
  - autoimmune diseases
  - developmental defects of the heart
  - underdeveloped thymus
  - delayed development cleft palate

### Cat's cry syndrome

- part of chromosome 5 is deleted
- 1 in 50,000 live births
- symptoms:
  - disorders of laryngeal development
  - slower physical and mental development
  - weak muscle tone
  - developmental defects of the heart
- Thanks to modern treatment, patients can now live to adulthood

## Balanced translocations

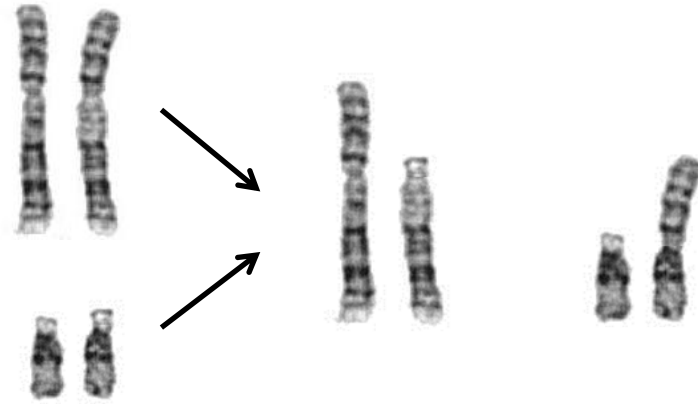

exchange of the parts between two different chromosomes

- genes are **relocated**, which can cause:

change in expression (eg when they come close to a strong promoter)

the **fusion** of two genes and formation of a **fusion product** with an undesired function

problems with chromosome pairing during gamete formation (meiosis)

# Chronic myeloid leukemia (CML) - Philadelphia chromosome

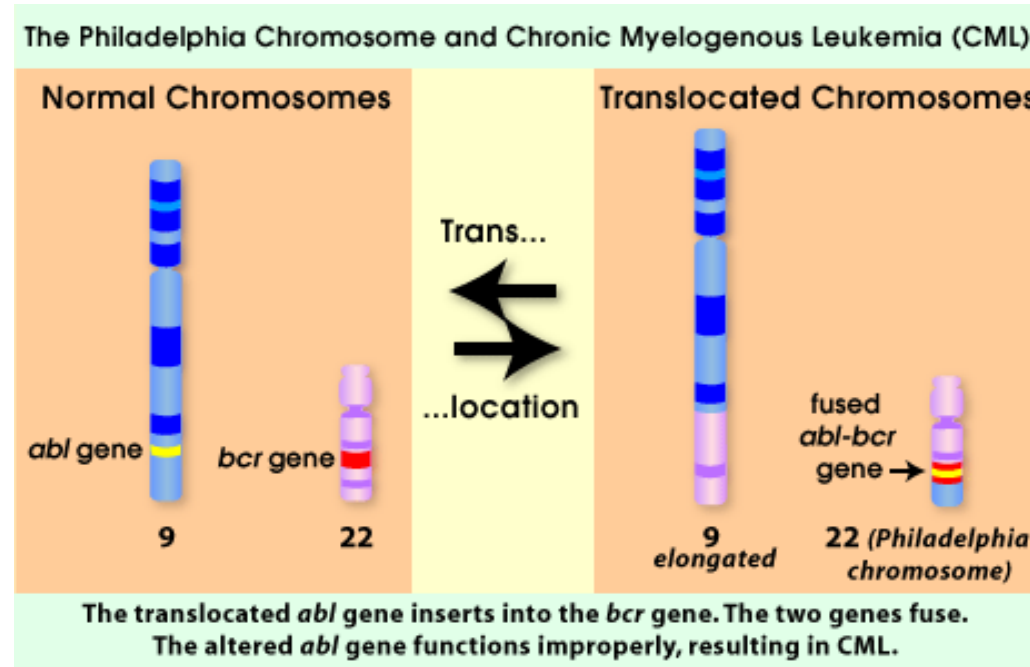

95% of all CML patients have a **Philadelphia chromosome**

- *abl* gene - a kinase regulating cell division, differentiation and cell survival (chromosome 9)
- *bcr* gene (chromosome 22)

fusion gene *bcr-abl* → **fusion protein** that has constitutive kinase activity → cell cycle deregulation, excessive leukocyte proliferation (leukemia)

# Objectives of the lecture – Introduction to Genetics I

Basic genetic terminology. Principle of dominance and recessivity. Mendelian inheritance. Monohybridism. Dihybridism. Interactions of non-allelic genes. Monogenic diseases. Autosomal recessive diseases (phenylketonuria, cystic fibrosis, sickle cell anaemia). Autosomal dominant disease (polycystic kidney disease, Huntington's disease). Gonosomal recessive diseases (haemophilia type A and B, Duchenne muscular dystrophy). Gonosomal dominant diseases (rickets). Intermediate inheritance (dominance and codominance, penetrance and expressivity, uniparental isodisomy, genomic imprinting). Chromosomal disorders. Chromosomal aneuploidy (numerical chromosomal aberrations) – Down syndrome, Edwards syndrome, Patau syndrome, Klinefelter syndrome and Turner syndrome. Structural aberrations of chromosomes.

**Figures adapted from** (if not stated otherwise):

SNUSTAD, Peter D., Michael J. SIMMONS. Principles of Genetics. Sixth edition. Wiley, 2011, 784. ISBN 9780470903599

**Thank you for your attention –  
any questions?**

