

# Basic staining methods in histology

How to use a light microscope

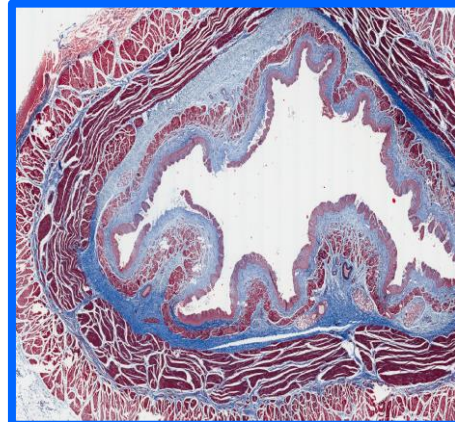
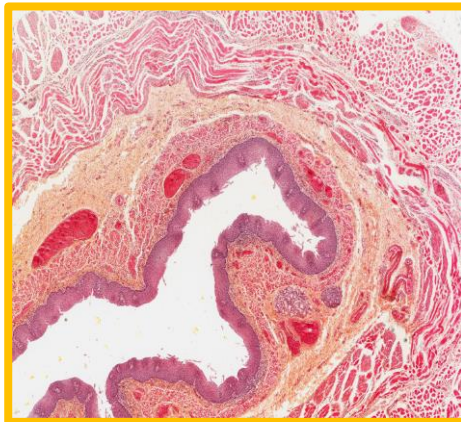
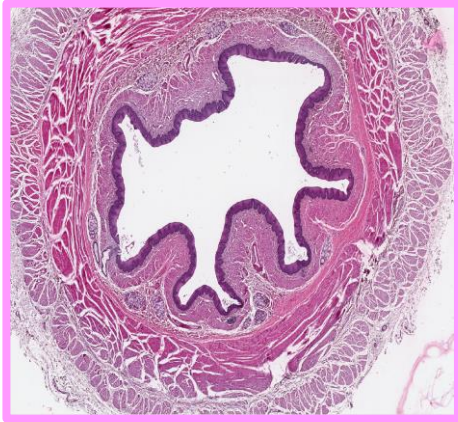

# STAINING

Different cell or tissue structures are not apparent without staining. Cellular structures exhibit different affinity to staining dyes:

**alkaline dyes** – react with anionic structures → **BASOPHILIA**  
(basophilic structures in the cell – nucleus, nucleolus, ribosomes, cytoplasm with rough ER)

**acid dyes** – react with cationic groups → **ACIDOPHILIA** –  
(acidophilic structures in the cell – cytoplasm, smooth ER)

no or weak reaction → **NEUTROPHILIA**

chromophilic (chromatophilic) x chromophobic  
polychromatophilic – affinity to both types of dyes

# HEMATOXYLINE – EOSIN (HE)

Deparaffination

Rehydration

Washing

Staining

Differentiation

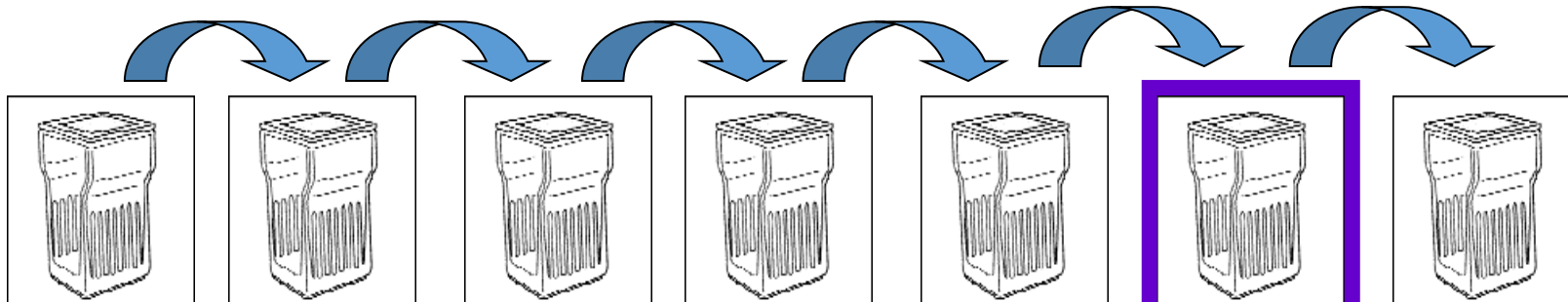

xylene I

xylene II

100%  
ethanol

96%  
ethanol

H<sub>2</sub>O

hematoxyline

acid  
ethanol

Clearing

Dehydration

Washing

Staining

Washing

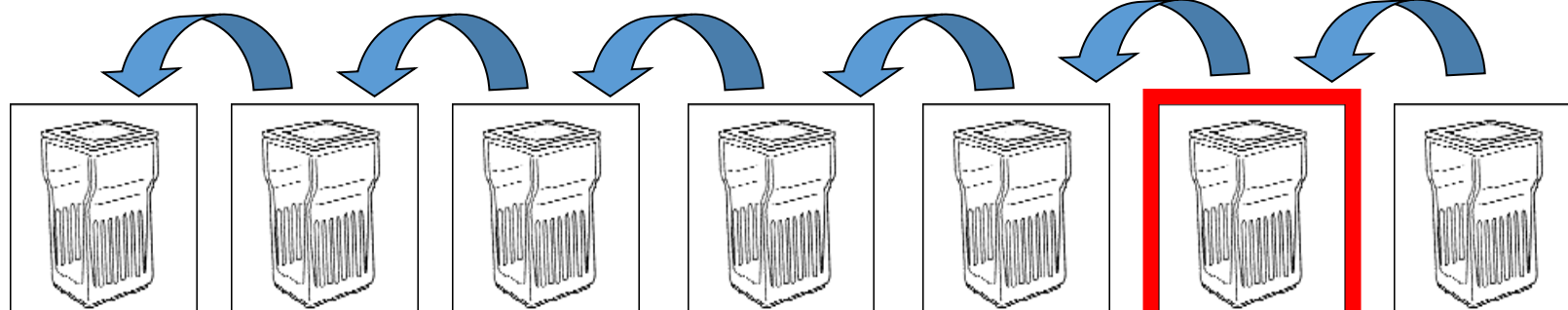

xylene IV

xylene III

100%  
ethanol

96%  
ethanol

H<sub>2</sub>O

eosin

H<sub>2</sub>O

# ROUTINE STAINING with HE

**Hematoxyline – basic (nuclear) dye**

**Eosin – acid (cytoplasmic) dye**



## Staining procedure:

- paraffin must be removed (dissolved) by xylene
- sections are rehydrated in descending series of ethanol (100% →96% →80%)
- staining with **hematoxyline**
- differentiation in acid ethanol and water (excess of dye is removed)
- staining with **eosin**
- rinsing in water (excess of dye is removed)
- dehydration in graded ethanol series (80% →96% →100%)
- clearing in xylene

# Automatic slide stainer



staining set of boxes with media

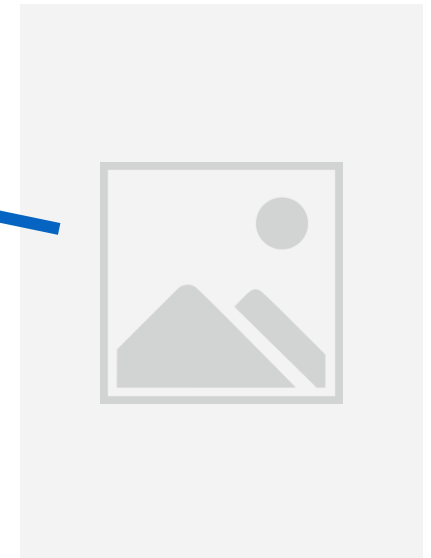

# TYPES of STAINING

- routine – HE (visualization of all tissue components), Masson's trichromes: yellow - HES, blue - AZAN, green trichrome (collagen fibers)
- special – visualization of particular structures only
  - orcein, aldehyde fuchsin, resorcin fuchsin - elastic fibres
  - PAS – polysaccharides
  - oil red, sudan black – lipids
  - Schmorl staining
  - impregnation –  $\text{AgNO}_3$  - nerve or reticular fibers

# AFFIXING

- attachment of sections by albumin/gelatin to microscopic glasses  $\Rightarrow$  permanent slide

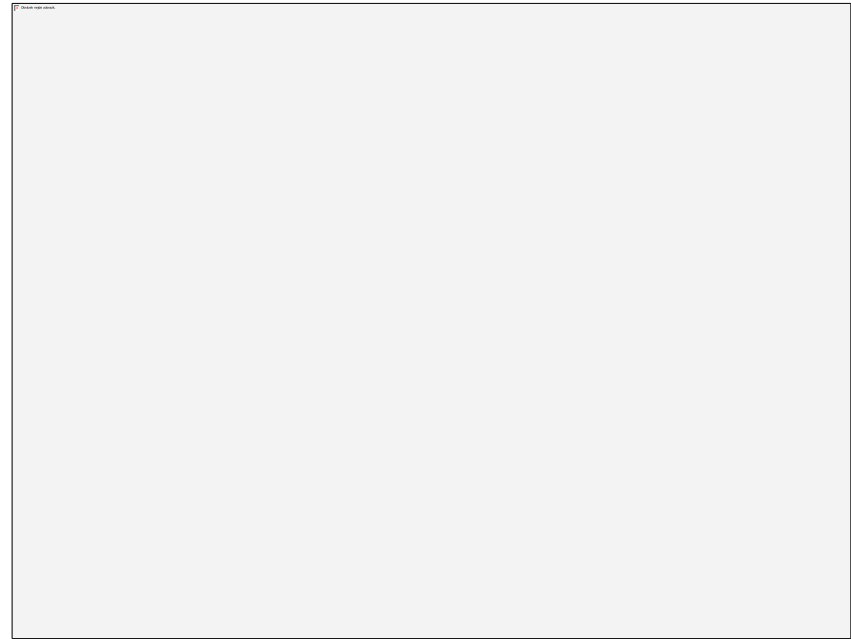
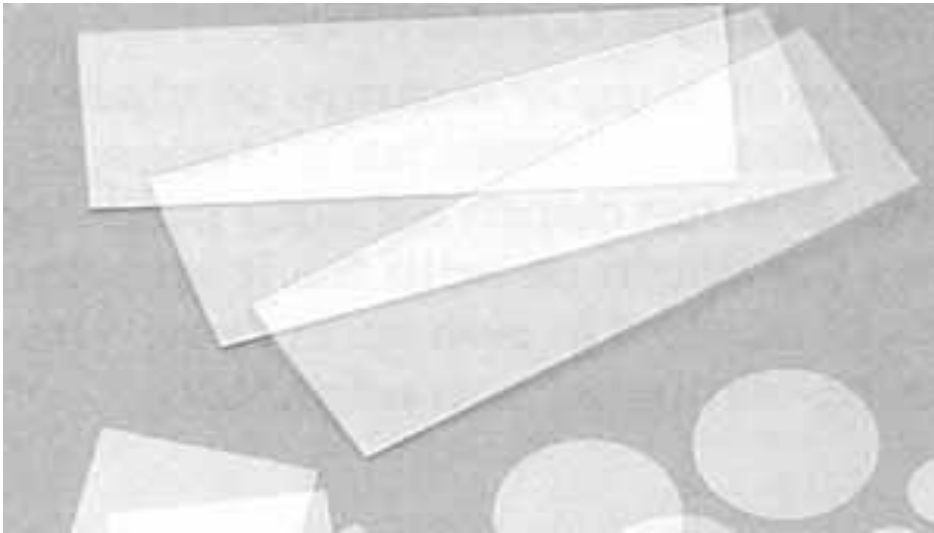

# Hematoxyline

## Eosin

### (HE)

Results of staining:

cell nuclei – blue/violet

cytoplasm – pink

collagen fibers – pink

muscle cells – dark

pink/red



2 – Apex linguae (HE)



**Hematoxyline**

**Eosin**

**Saffron**

**(HES)**

Results of staining:

cell nuclei – blue/violet

cell cytoplasm – pink

collagen fibers – yellow



yellow Masson trichrom

**11 – Oesophagus (HES)**

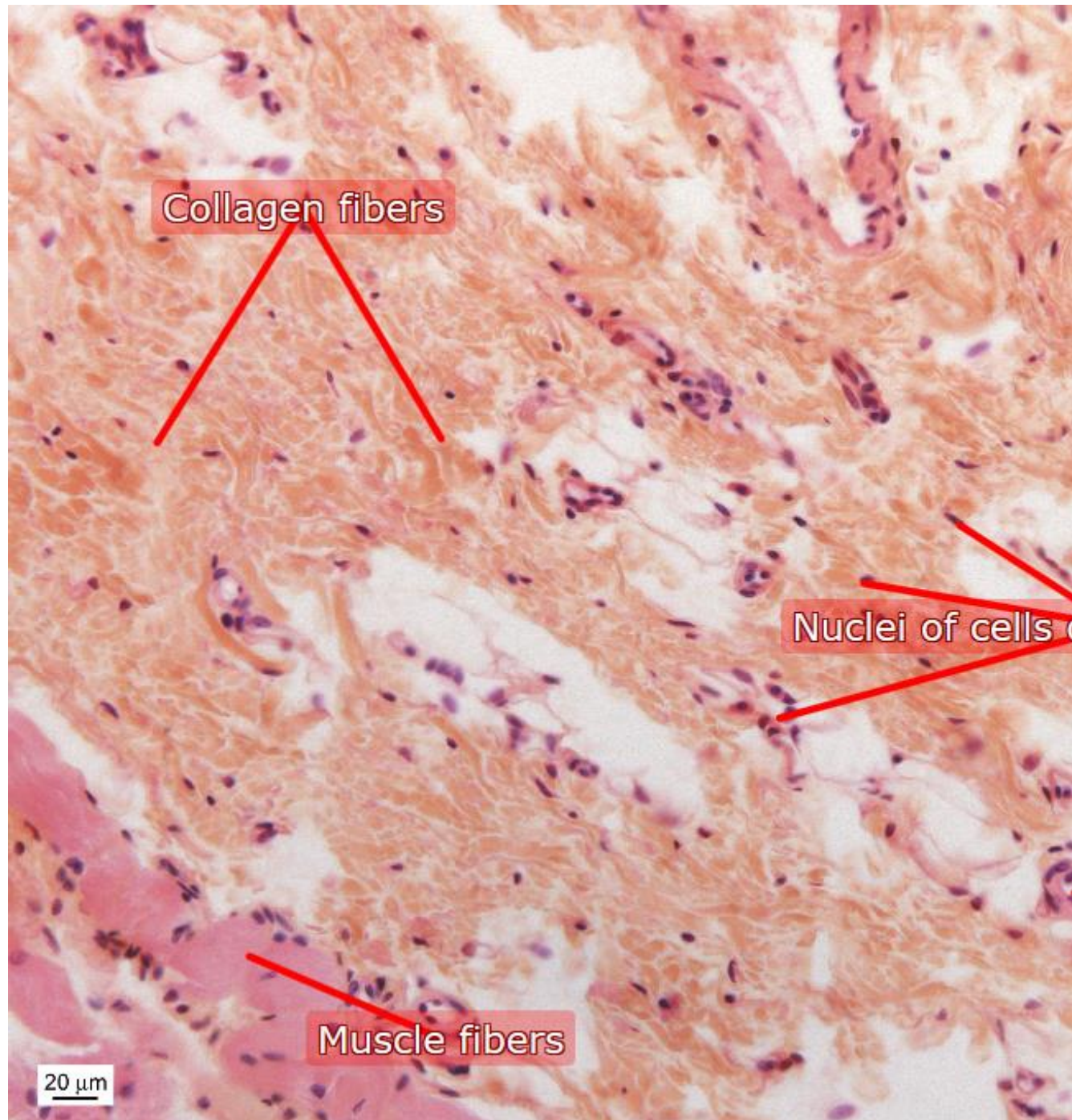

**Azokarmin**  
**Aniline blue**  
**Orange G**  
**(AZAN)**

Results of staining:

- cell nuclei – purple
- cell cytoplasm – pink
- collagen fibers – blue
- erythrocytes – orange



blue trichrome

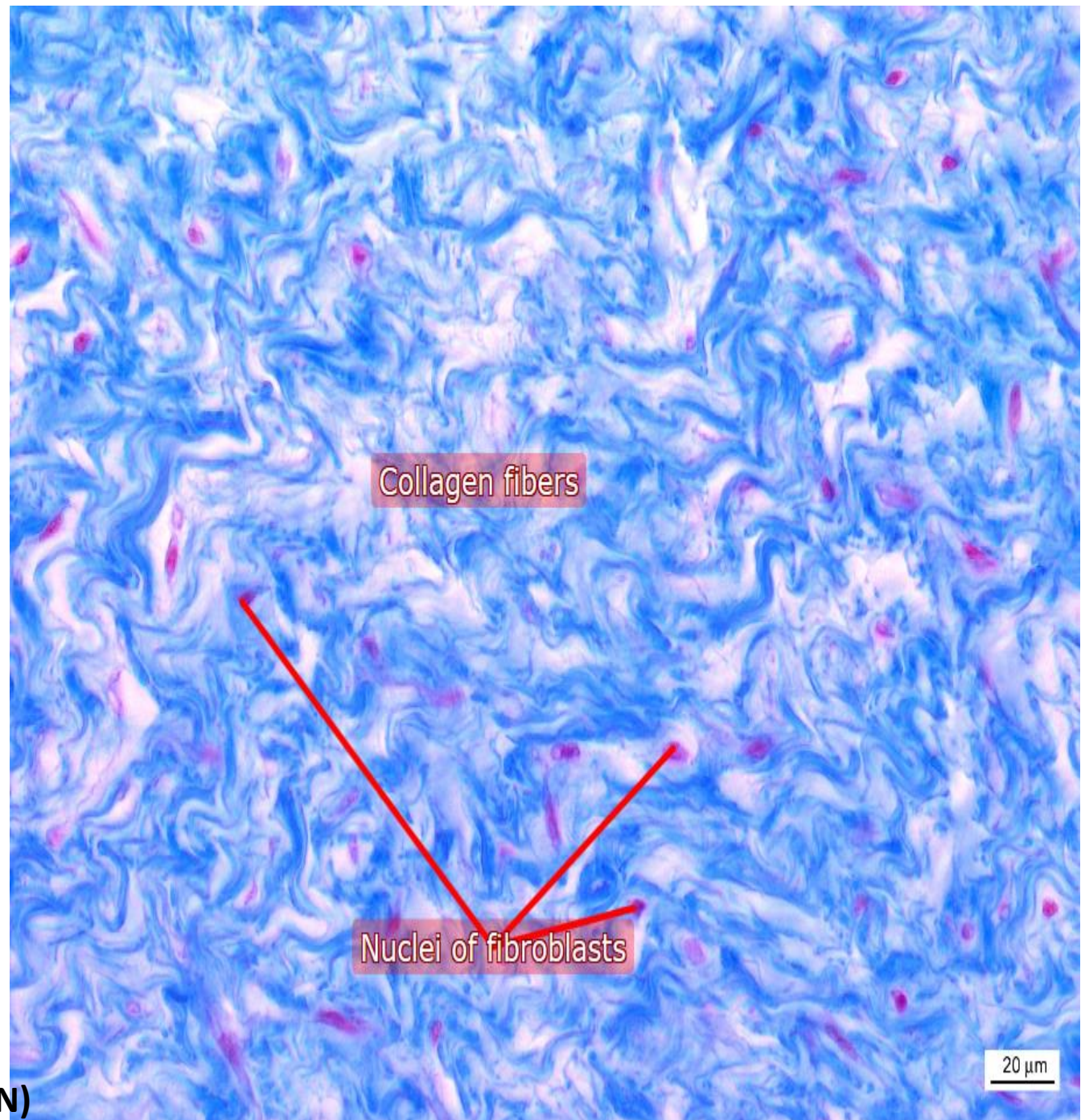

# Impregnation with $\text{AgNO}_3$

Slide 68 – lien

Staining – **impregnation**

Result – **black reticular fibers**

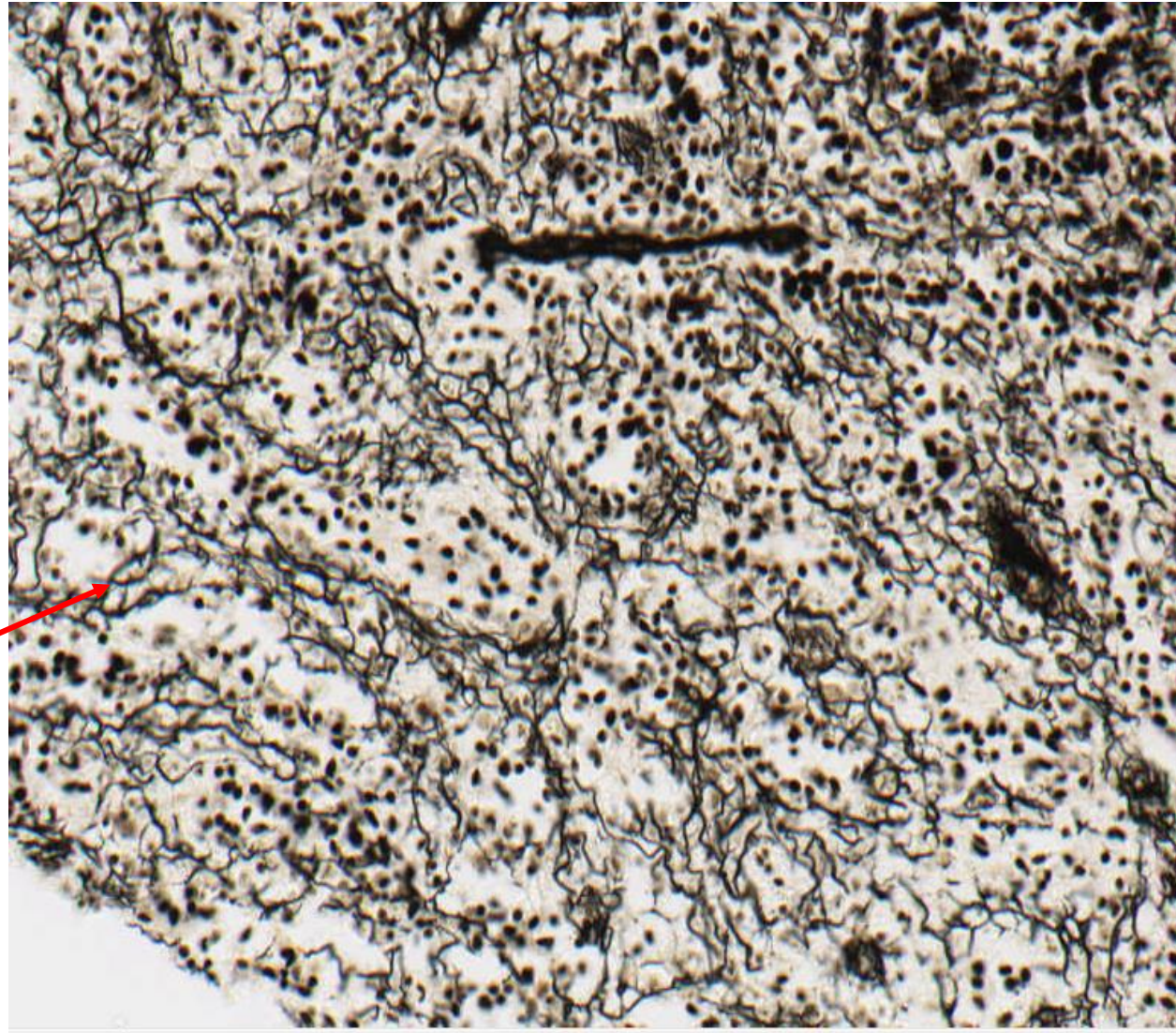

# Impregnation with $\text{AgNO}_3$

Slide 77 – cerebellum  
Staining – **impregnation**  
Result – **black nerve processes**

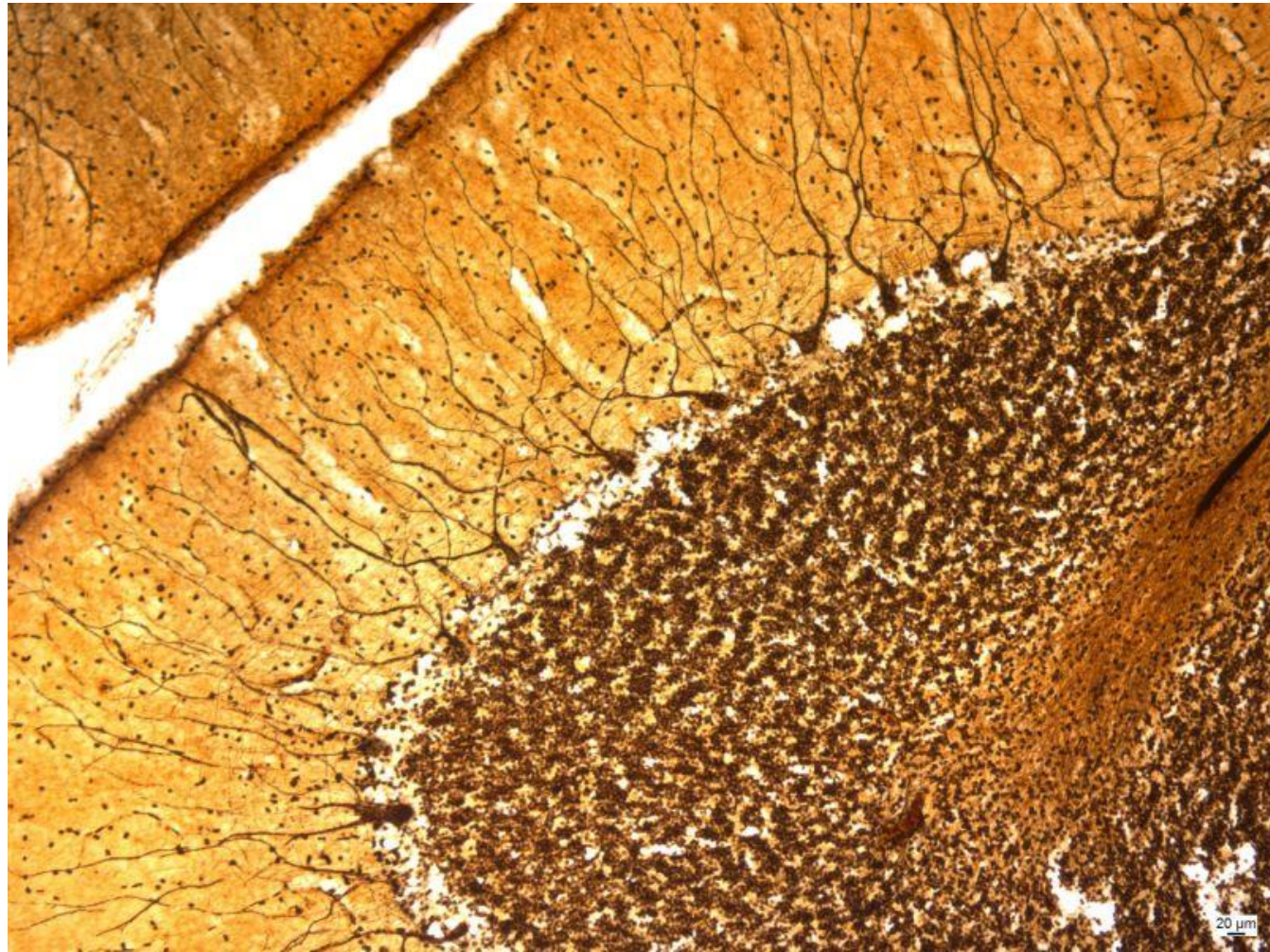

# Orcein

Slide 28 – elastic cartilage

Staining – **orcein**

Result – **red-brown elastic fibers**

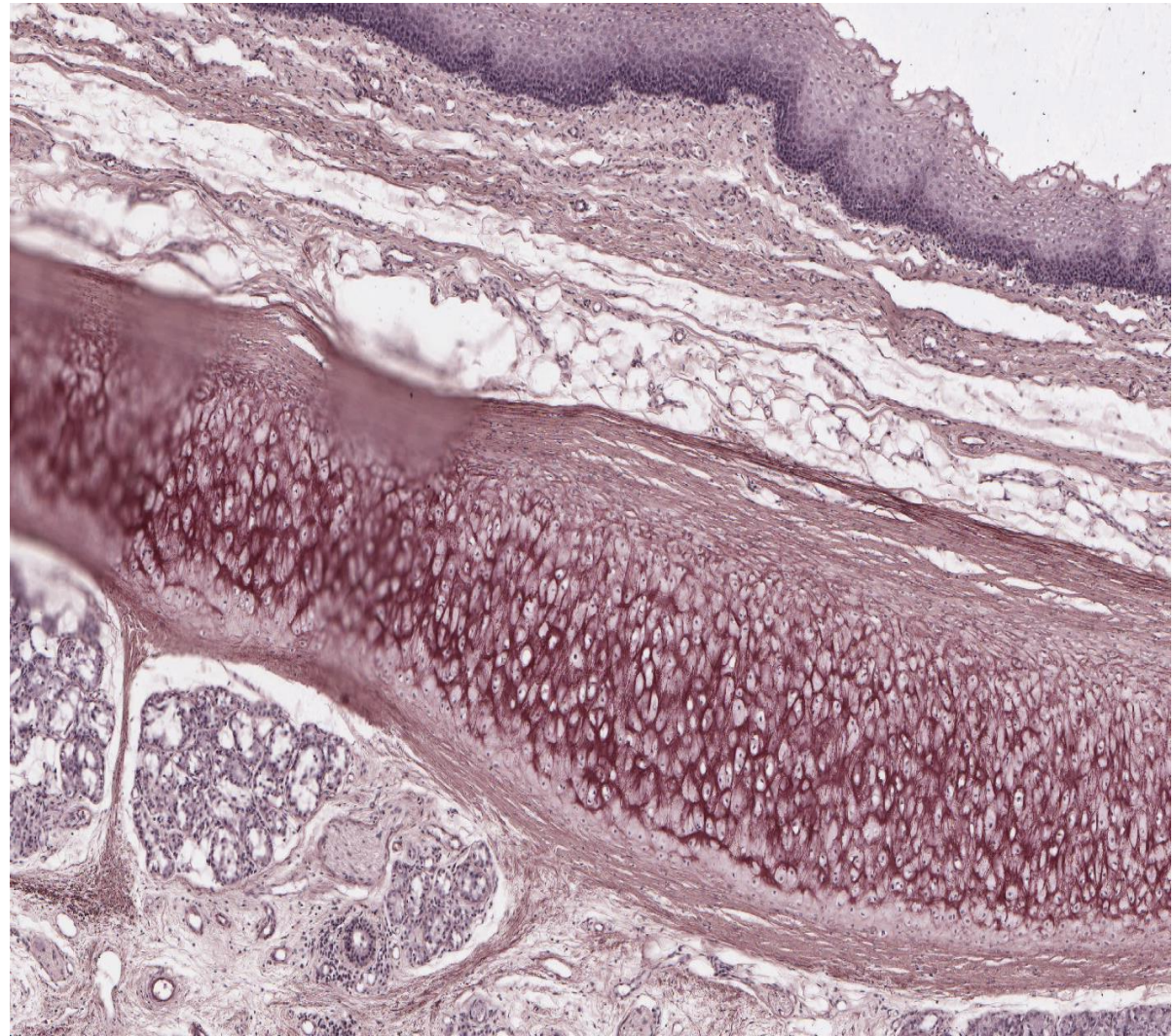

# Weigert-van Giesson

Slide 31 – renal cortex

Staining – **Weigert-van Giesson**

Result – **cherry-red collagen fibers**

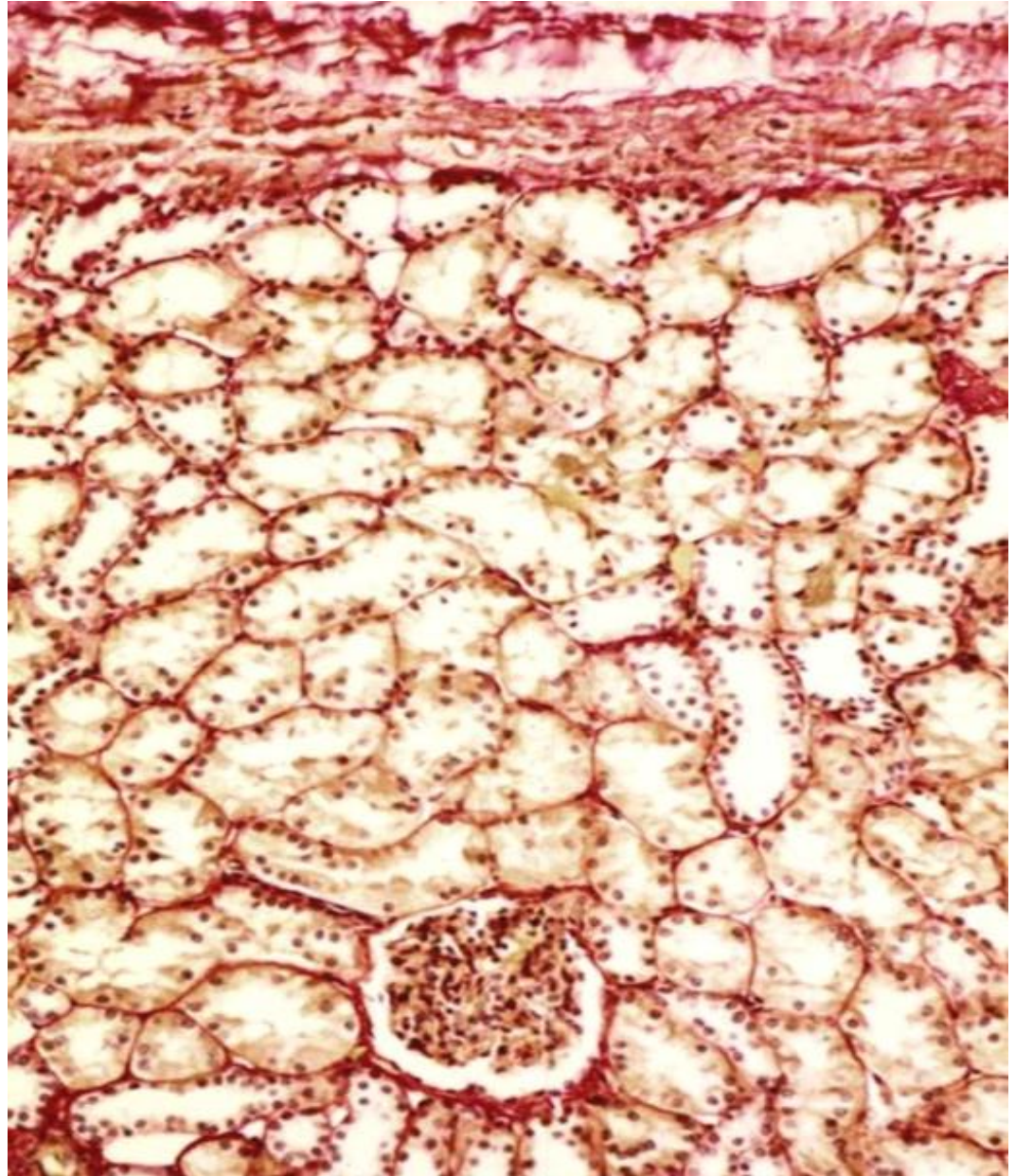

# Best carmine

Slide 49 – vagina - glycogen  
Staining – **Best carmine**  
Result – **dark pink glycogen**

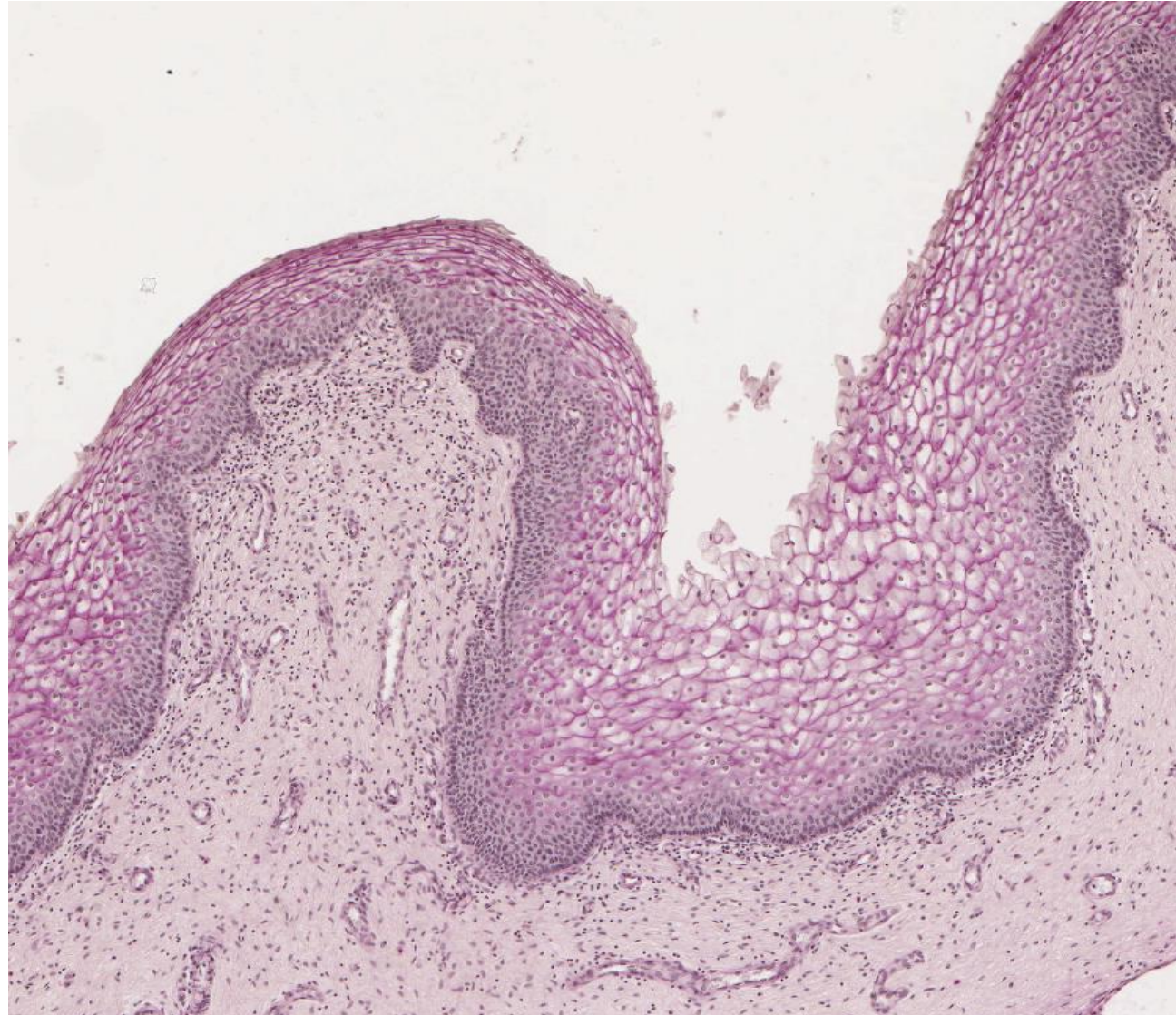

# Heidenhain

Slide 65 – myocardium  
Staining – **Heidenhain**  
Result – **black**  
**cardiomyocytes** (cross-  
striation)

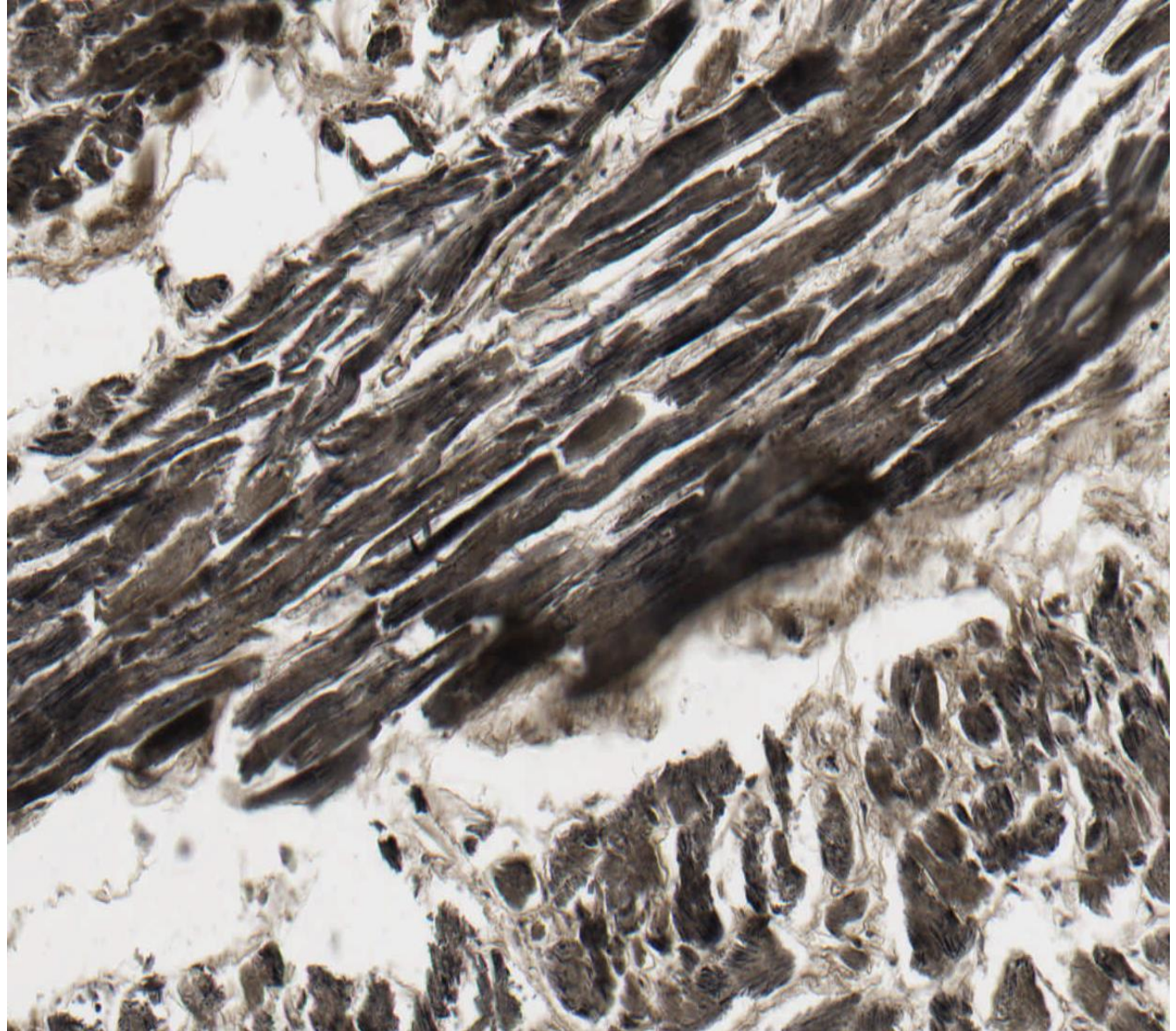



# Schmorl

Slide 95 – bone  
Staining – **Schmorl**  
Result – rusty brown  
**bone tissue**

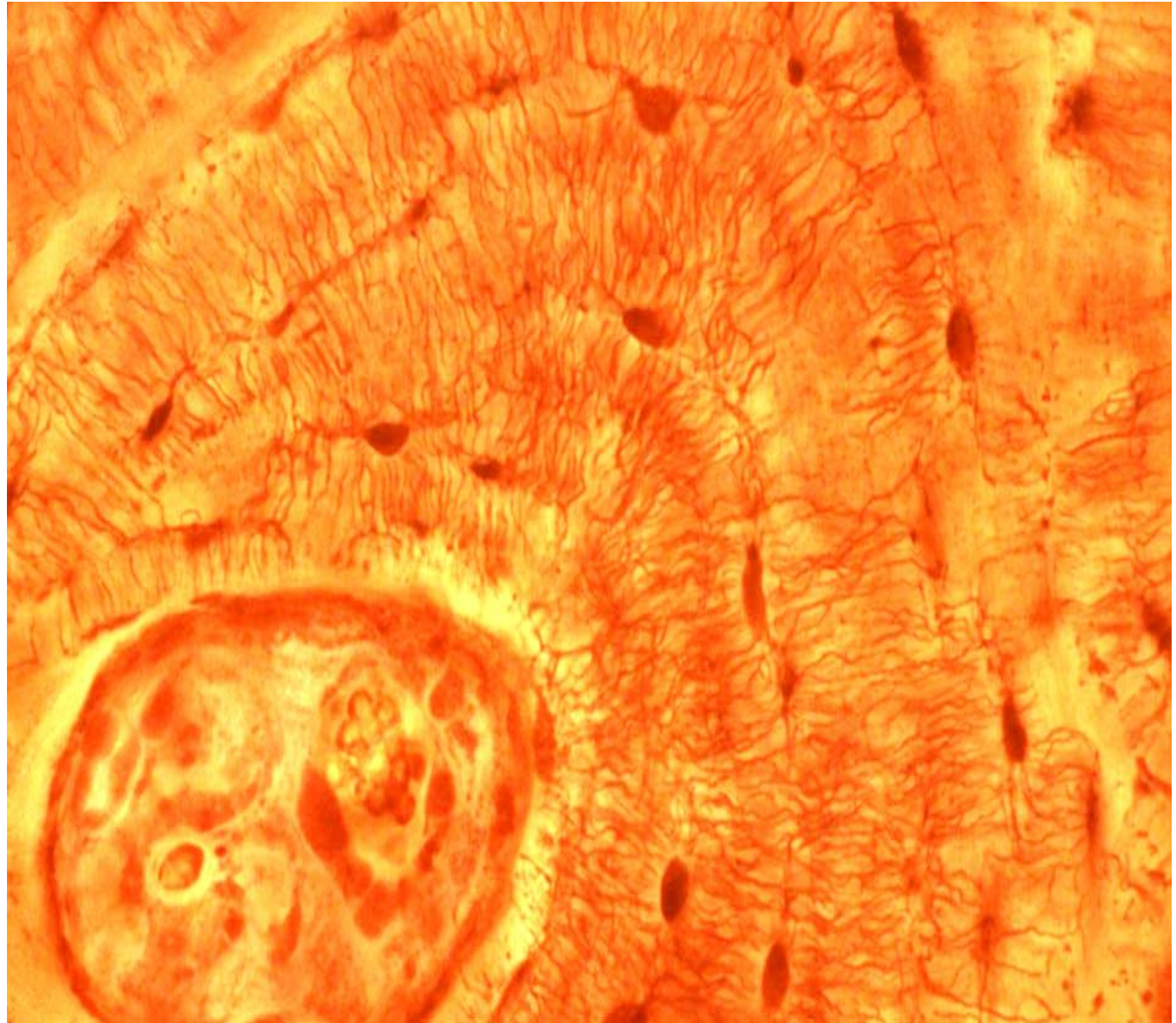

# APPEARANCE OF 3D OBJECTS IN 2D SECTIONS

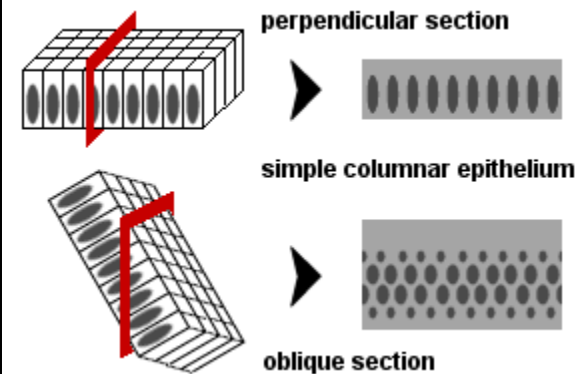
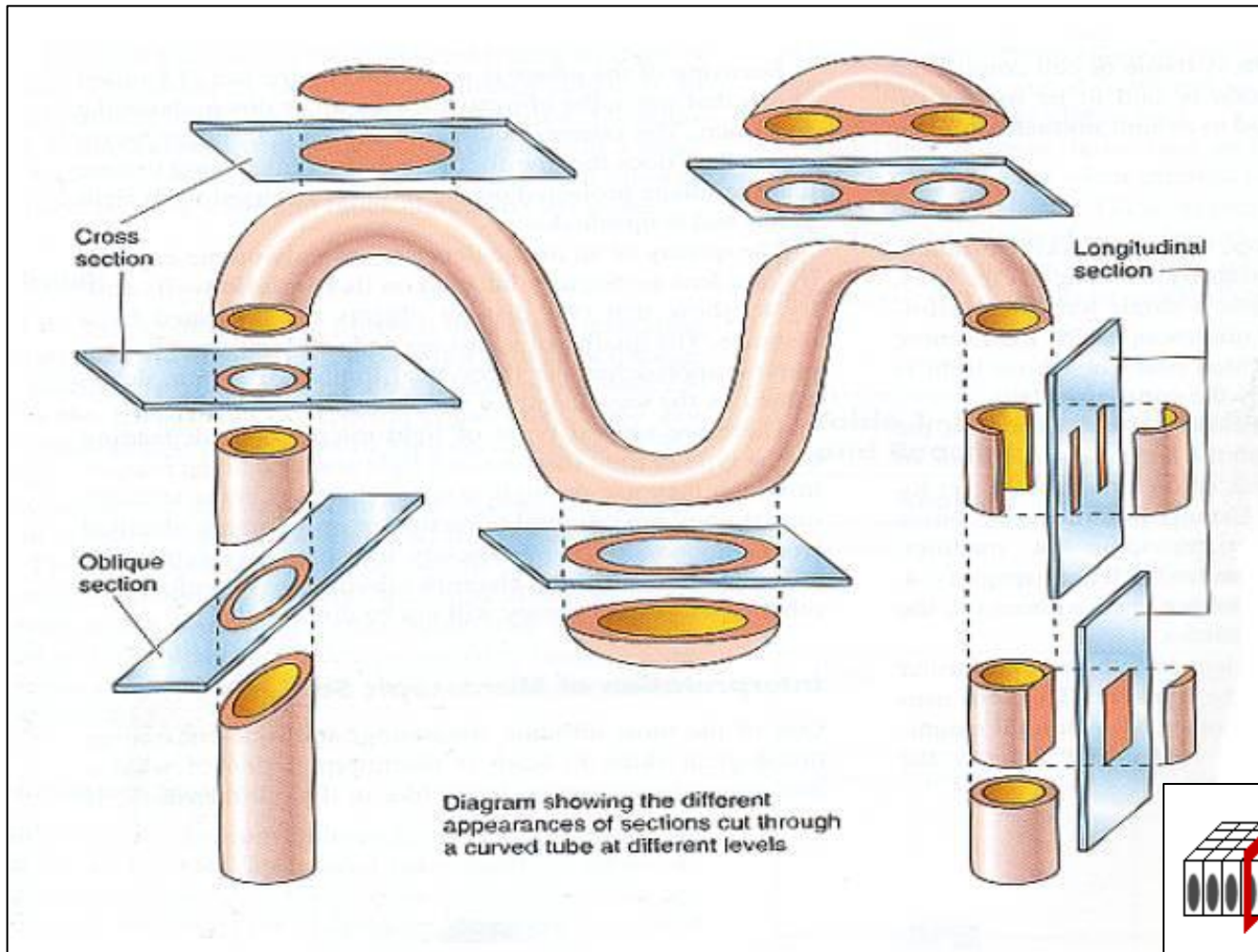

# Light microscope

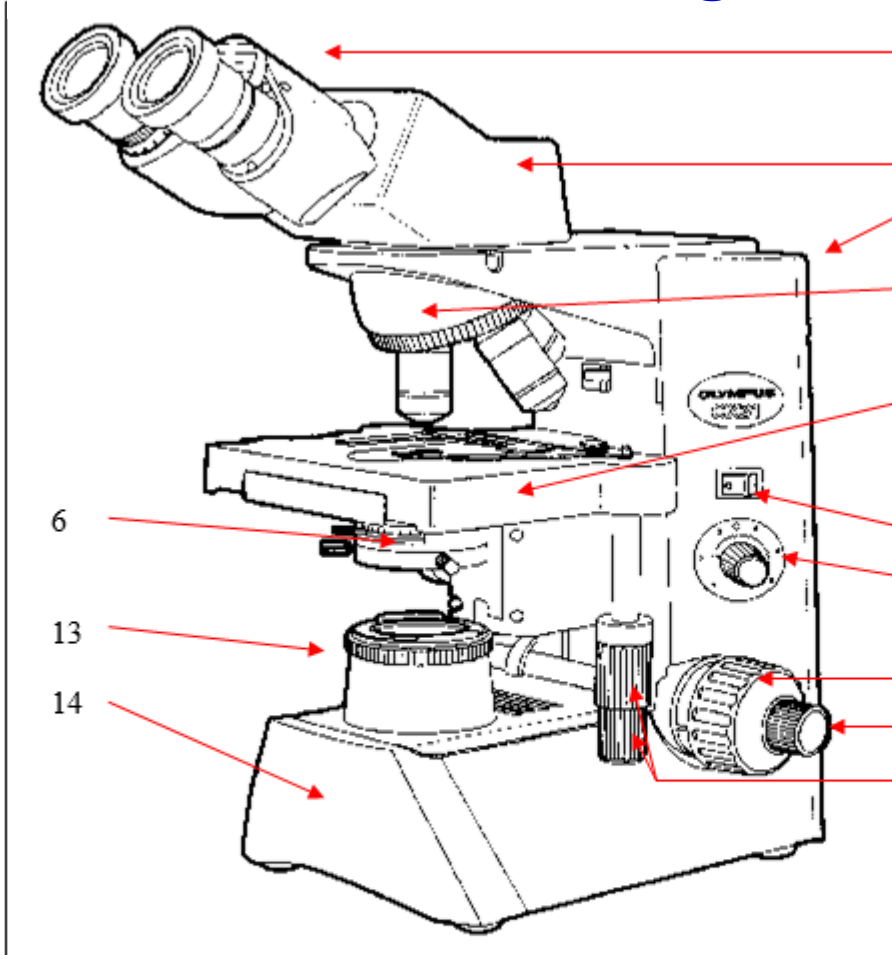

1 – eyepiece (ocular)  
(magnif. 10x)

pointer!

2 – revolving ocular tube

3 – arm of tube

4 – revolving head with  
objectives (magnif. 4x,  
10x, 40x, 100x)

Obj. 100x / don't use it!

5 – stage with cross-shaped  
shift

stage clip holds the slide on stage

6 – condenser with  
iris diaphragm

7 – switch on/off knob

8 – light intensity control  
knob

FOCUSING KNOBS (9,10)

9 – coarse adjustment

9 – use only when using objective 4x

10 – fine adjustment

11, 12 – knobs for shift  
of slide

13 – light source

14 – base (stage)

The slide must lie on the stage (5) of LM so that the cover glass faces up to the objective lens.

Magnification: of eyepiece = 10x

of objectives = 4x, 10x, 40x, immersion objective = 100x

Total magnif.: ocular magnif. multiplied by objective magnif. = 40x, 100x, 400x, 1000x

# Light microscope

- Eyepieces *pointer!*
- Objective lens
- Stage with specimen holder
- On/Off
- Light control
- Condenser and Iris aperture
- Stage controls
- Coarse focus - *use only when using objective 4x*
- Fine focus
- Light source with diaphragm

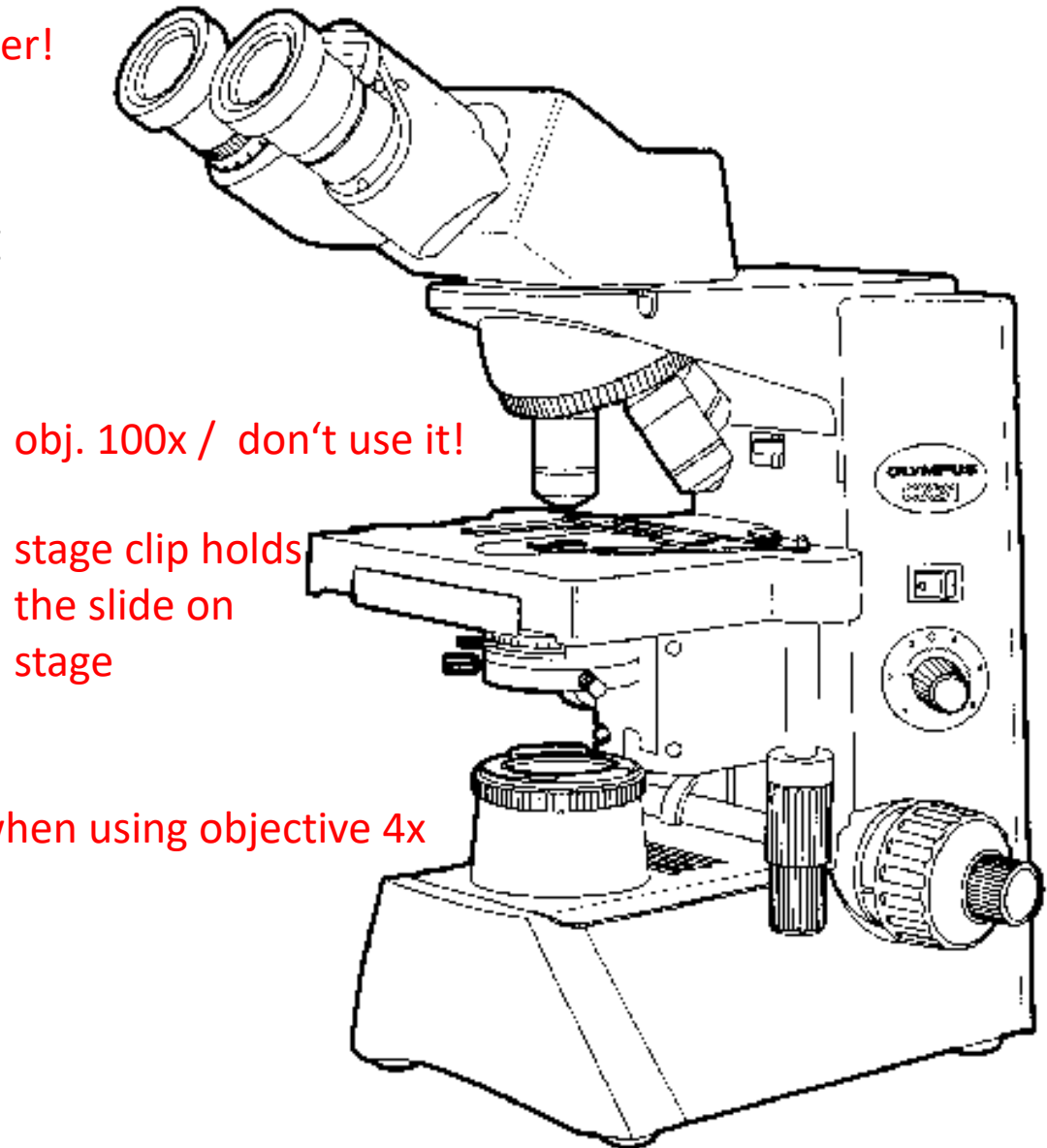

## HOW TO HANDLE A SET OF SLIDES

- Rule 1: ***At the beginning*** of each practice, check the set of slides and any defects (missing or broken slide) report to teacher.
- Rule 2: **Only one slide** can be taken out of the box and studied in LM.
- Rule 3: The slide must lie on the stage of LM so that the cover glass faces up to the objective lens.
- Rule 4: Treat the slides carefully; in case of damage of slide, inform the teacher.
- Rule 5: ***At the end*** of each practice, the box with slides must be open for inspection and student must wait at workplace during inspection.

# Instructions

- Turn on the light.
- **Start with the 4x objective.**
- Put the slide on the stage – cover glass must be above
- Look through the scope and focus. Use the coarse focus knob at first, until the image is more or less in focus; then switch to the fine focus.
- Adjust the light. Not too bright, not too dim.
- Adjust the oculars.
- Switch to the 10x objective. A slight adjustment with the fine focus knob should get it just right. If you lose the focus and can't see your specimen at all, go back to the 4x and start again.
- Switch to the 40x objective if you want to see more detail. **Don't use the 100x!**
- When you want to look at a new slide, switch back to the 4x before changing slides.
- **Only one slide is out of the box at the moment!** Do not remove more!
- When you're done with the scope, switch to the 4x and turn the light all the way down before turning it off.
- At the end of lesson, the box with slides is checked in your presence before you leave your place

