

MULTIFOKÁLNÍ BRÝLOVÉ ČOČKY

Prizmatický účinek

deviace

$$\delta = (n - 1)\omega$$

prizmatický účinek

$$\Delta \text{ (pD)} = 100 \frac{h(\text{m})}{z(\text{m})} = 100 \text{tg}\delta = \frac{h(\text{cm})}{z(\text{m})}$$

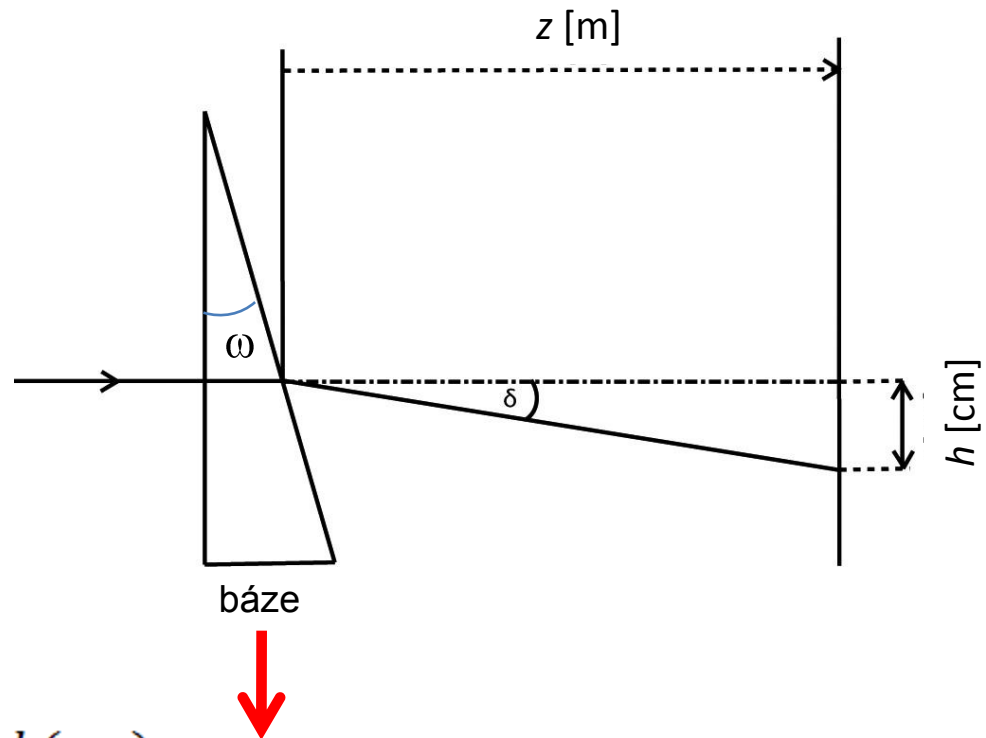

Prizmatický účinek

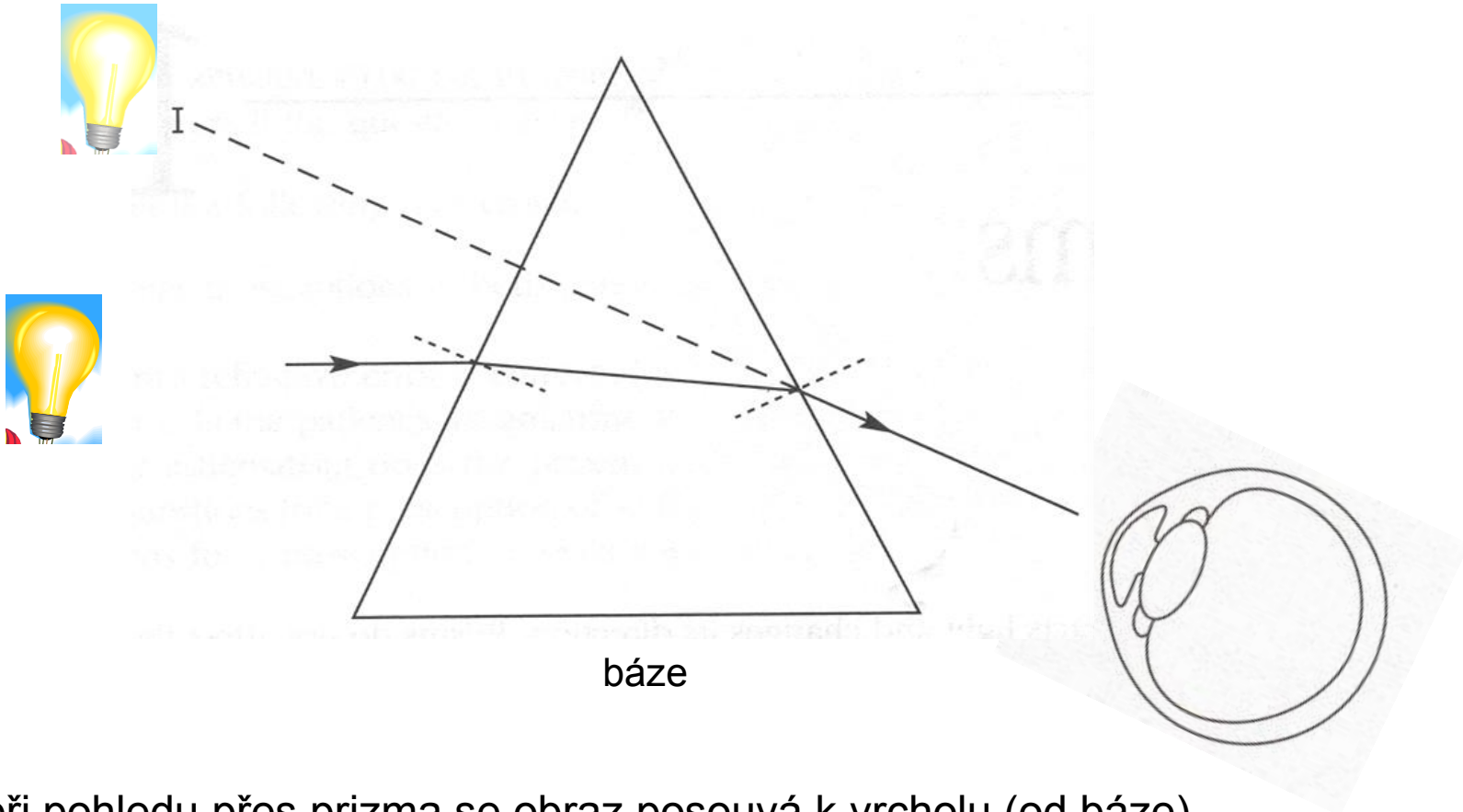

při pohledu přes prizma se obraz posouvá k vrcholu (od báze)

Prizmatický účinek čočky

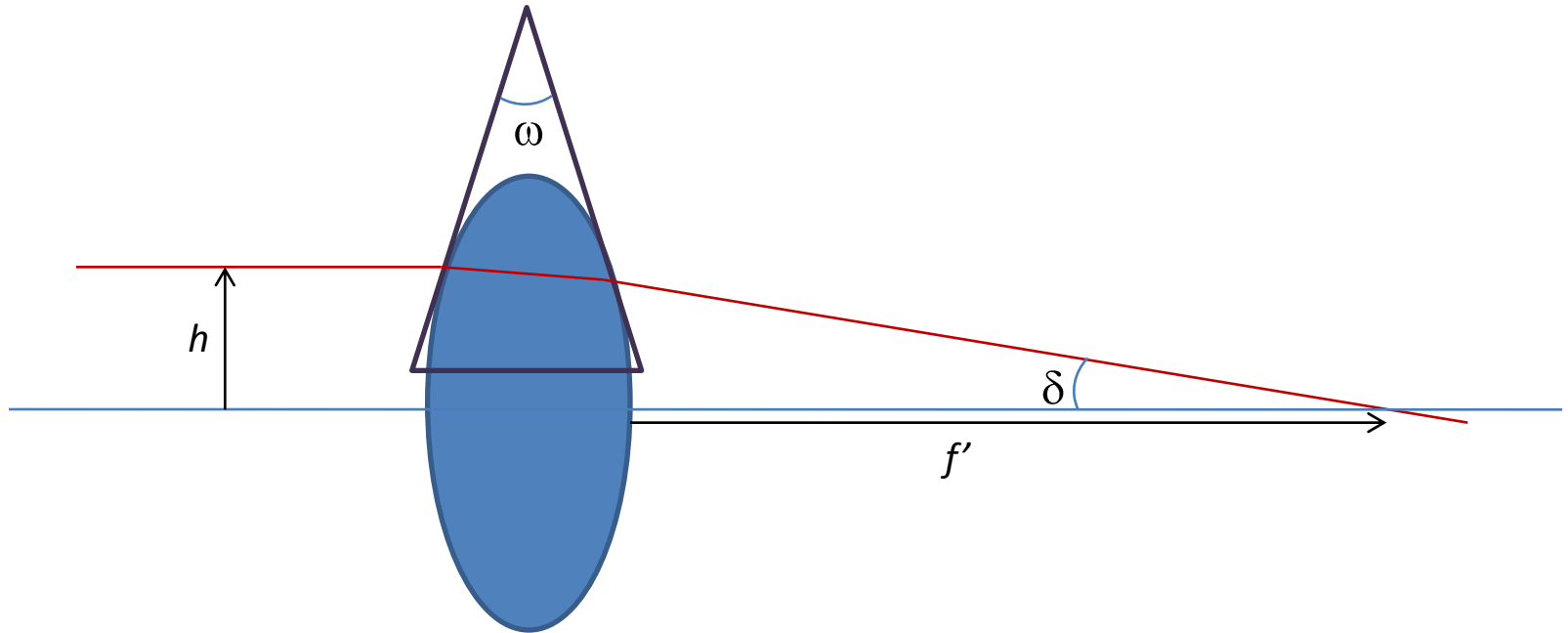

$$\Delta \text{ (pD)} = 100 \operatorname{tg} \delta = 100 \frac{h(\text{m})}{f'(\text{m})} = 100 h(\text{m}) \varphi'_c(\text{D}) = h(\text{cm}) \varphi'_c(\text{D})$$

„Prenticeho pravidlo“ (Prentice's rule)

Prizmatický účinek čočky

$$\Delta \text{ (pD)} = \frac{\text{dec (mm)} \varphi'_c \text{ (D)}}{10}$$

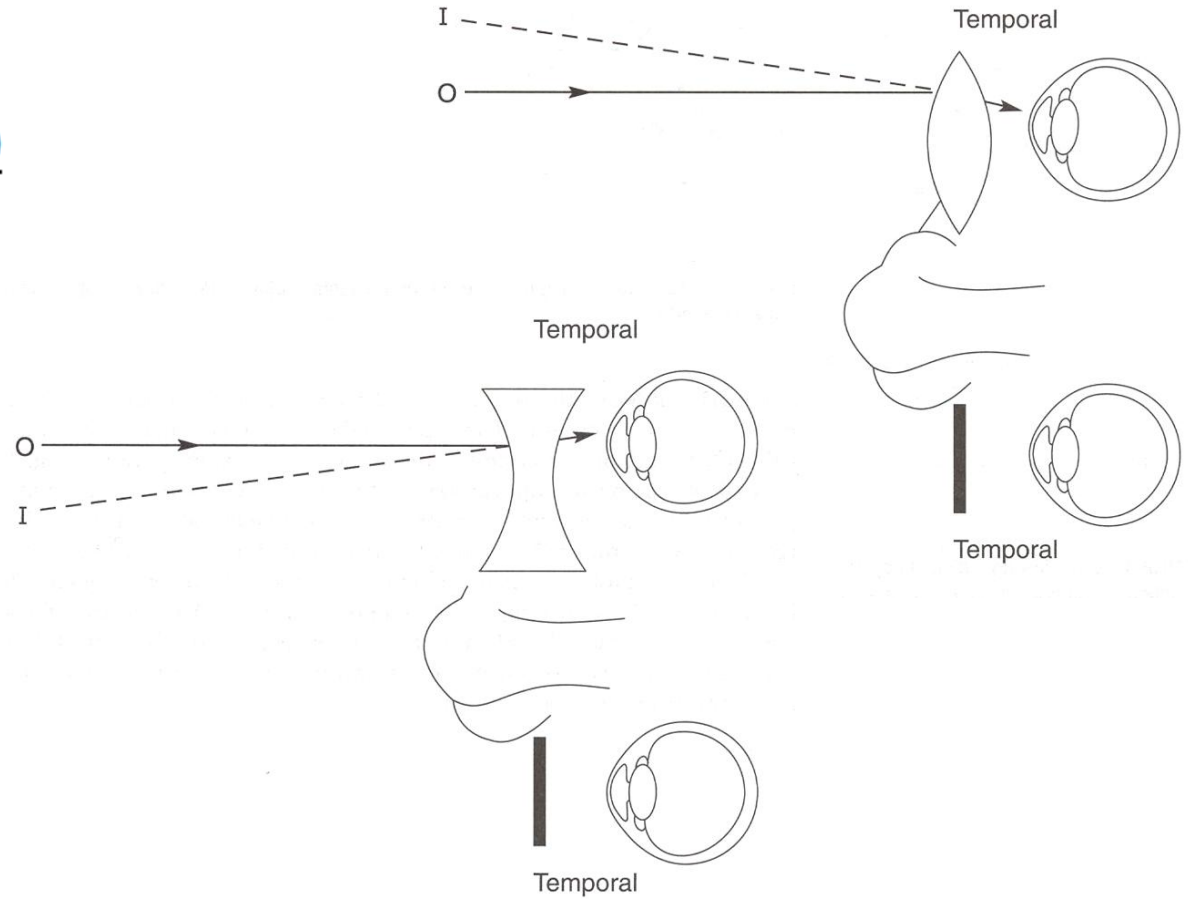
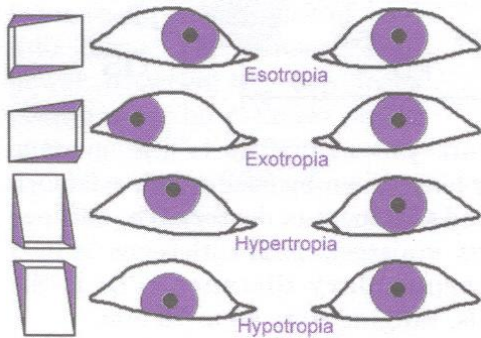

Vynález bifokálních čoček

Benjamin Franklin

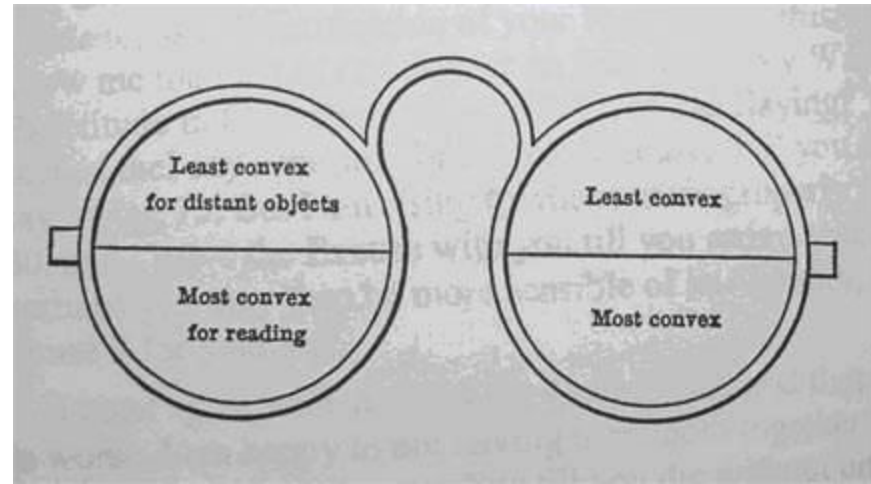

nákres z dopisu – knihovna kongresu

A handwritten signature in cursive script, reading "B. Franklin". The signature is written in black ink and has a long, sweeping underline.

Požadavky na bifokální čočky

- Řádné centrování obou dílů vůči oku (optické osy procházejí středem otáčení oka).
- Korekce periferního astigmatismu obou dílů (bodově zobrazující čočky).
- Odstranění „skoku obrazu“ na předělu (shodný prizmatický účinek na předělu).
- Vhodné provedení z hygienického a estetického hlediska (bez vroubku).

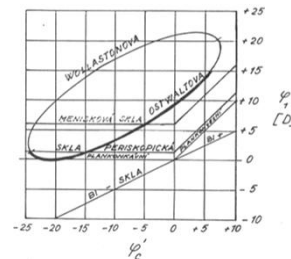
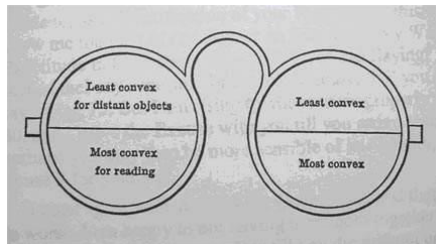
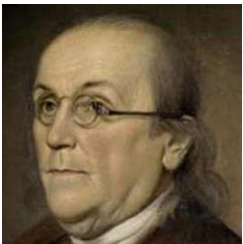

Centrování dílů bifokální čočky

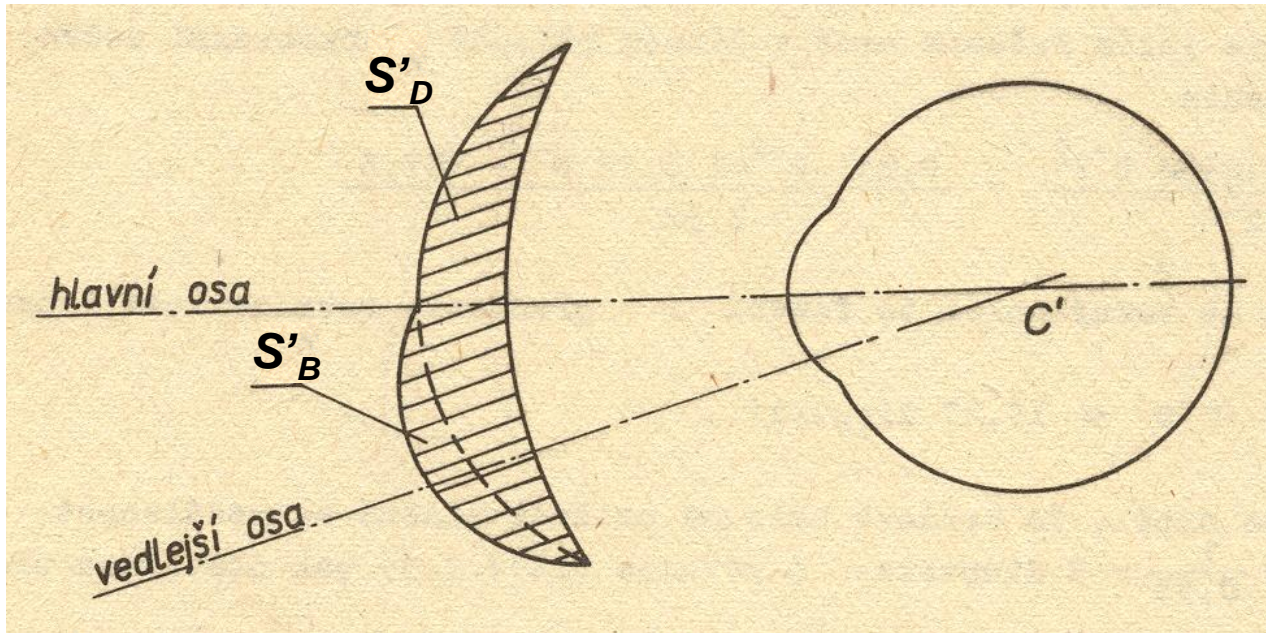

Skok obrazu u vybrušované bifokální čočky

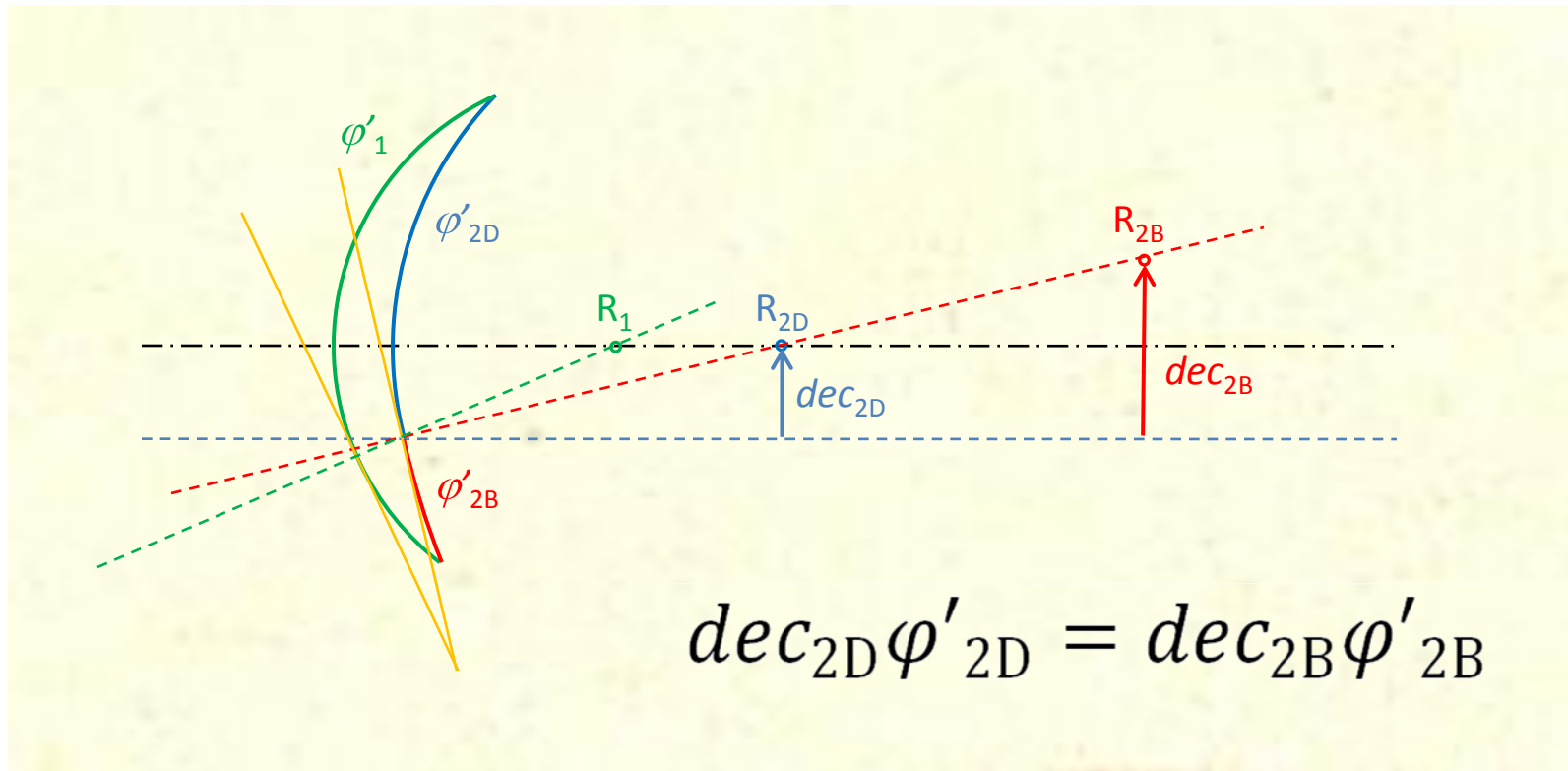

Akomodační intervaly pro bifokální čočku

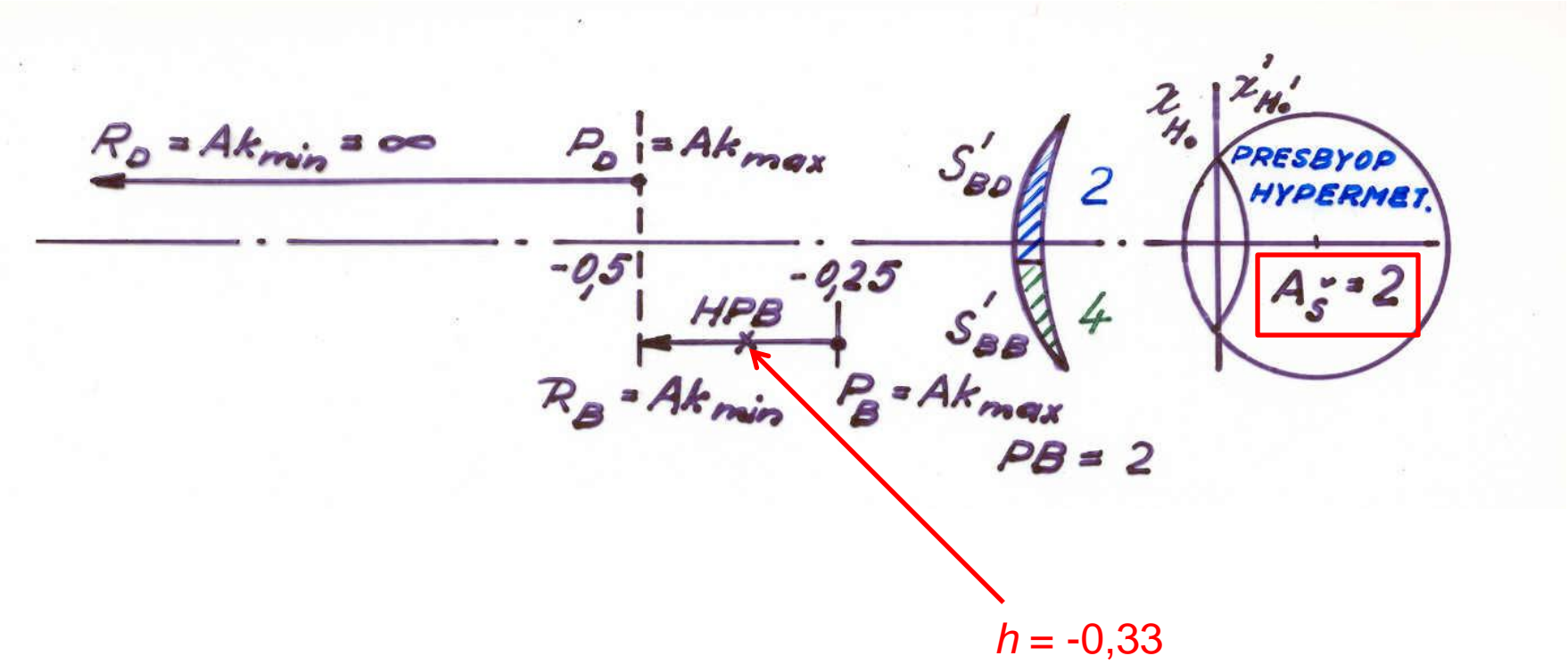

Akomodační intervaly pro trifokální čočku

PMZ = 1 D
PB = 2 D

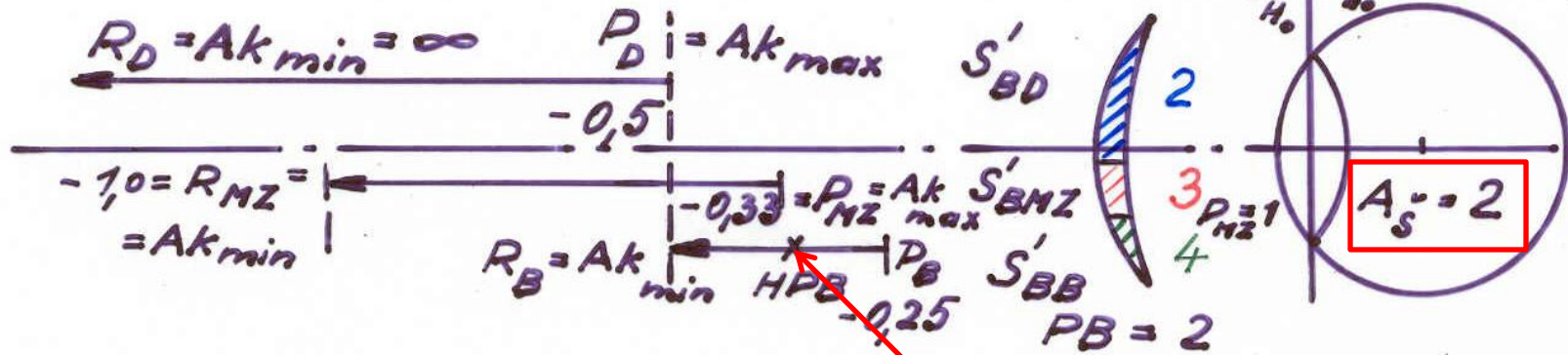

$h = -0,33$

Pokles akomodační šíře na +1D

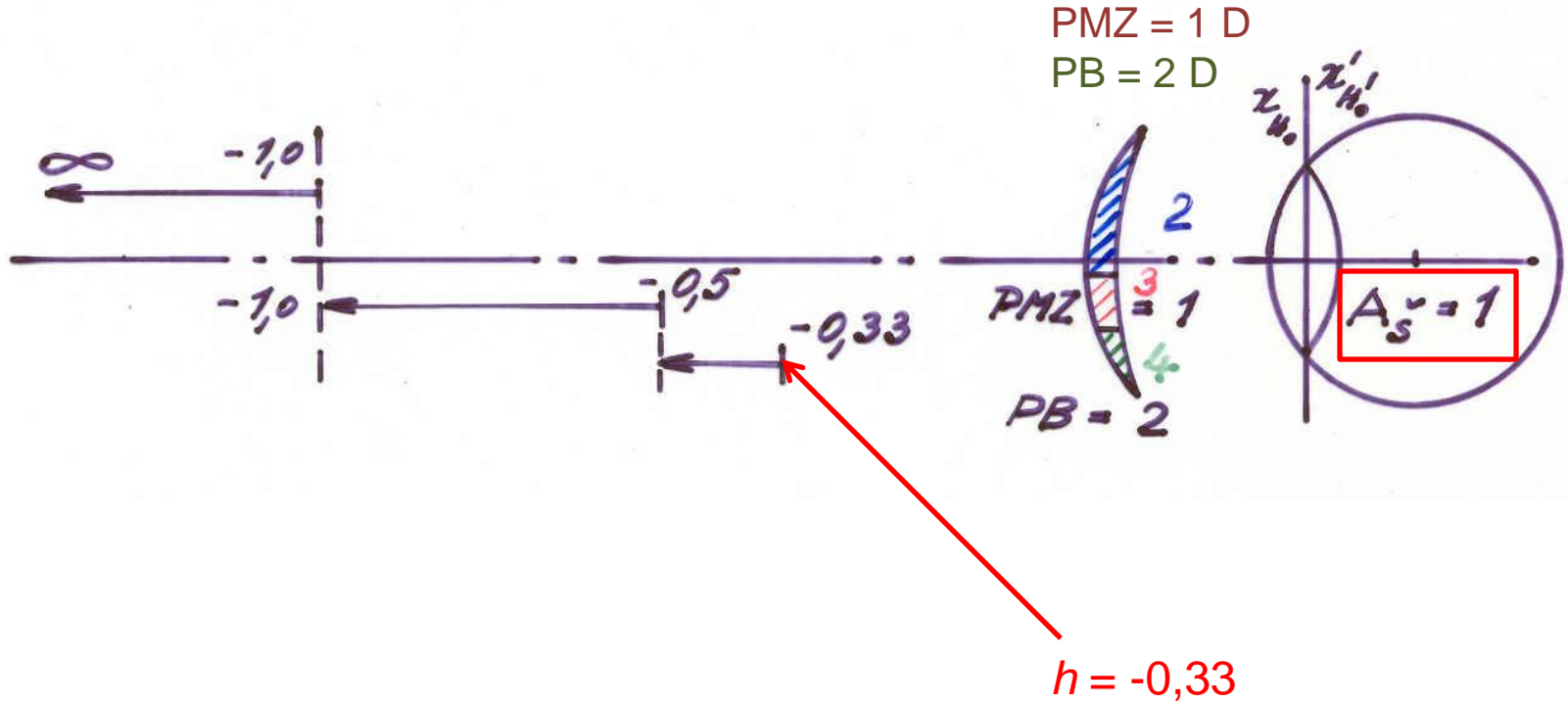

Zvýšení přídavku do blízka na +2,5 D

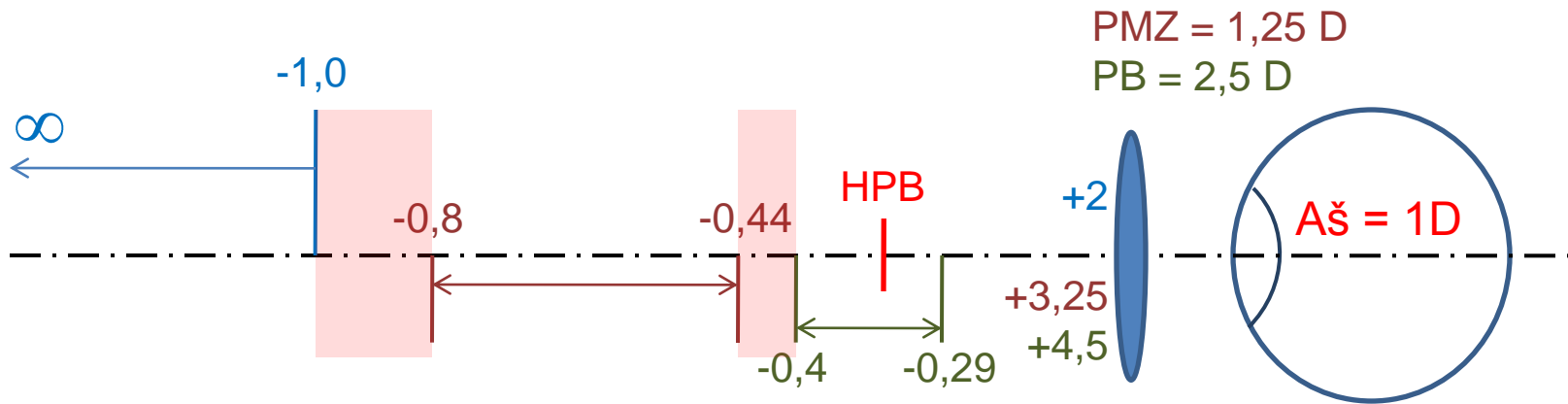

Zatavované bifokální čočky

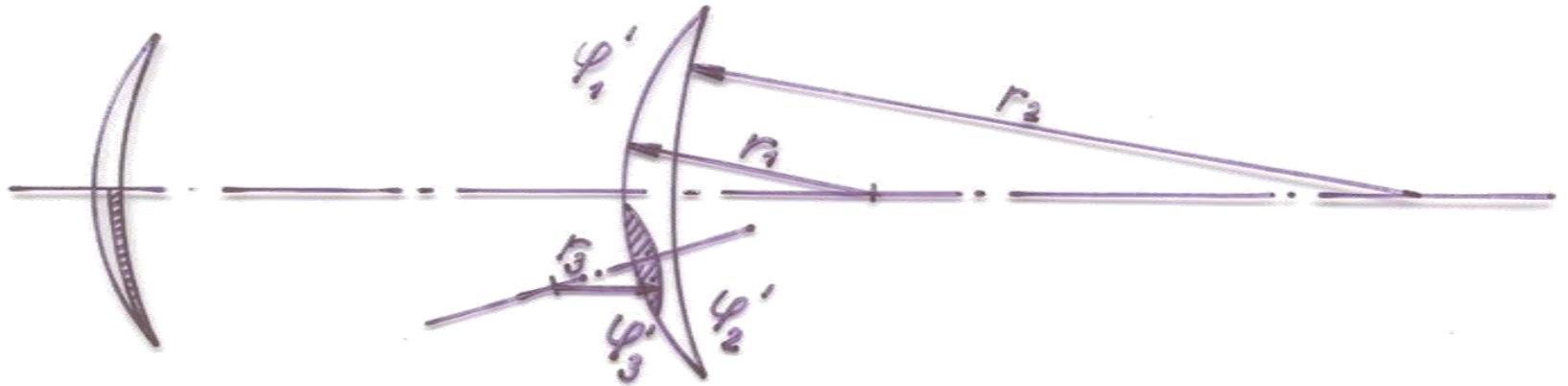

Příklady bifokálních čoček

DUOPAL

BONOVISTA

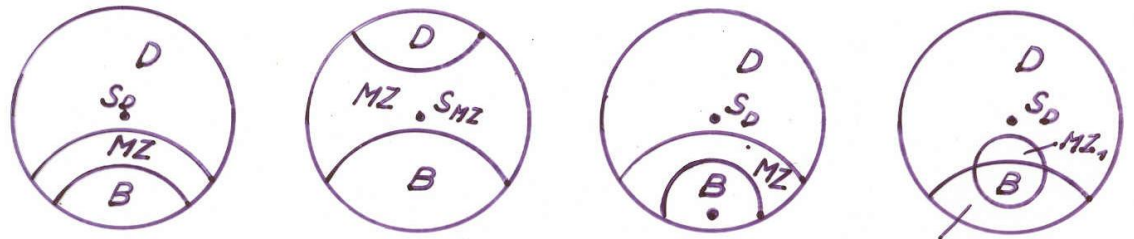
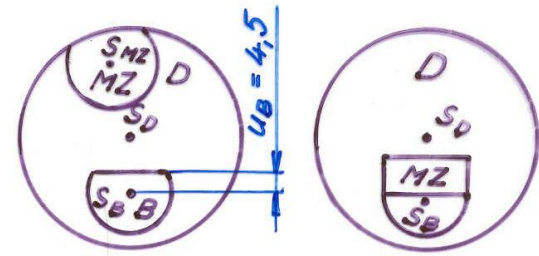
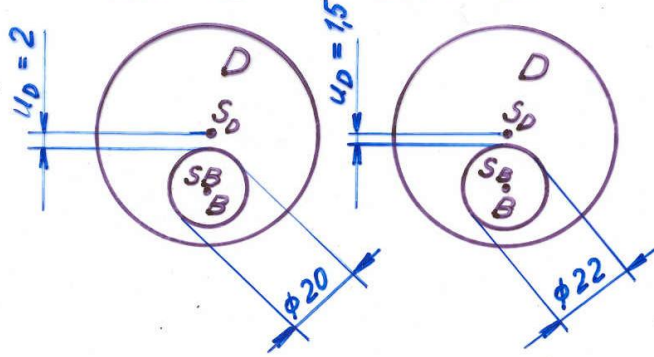

STRALUX eSTěčko

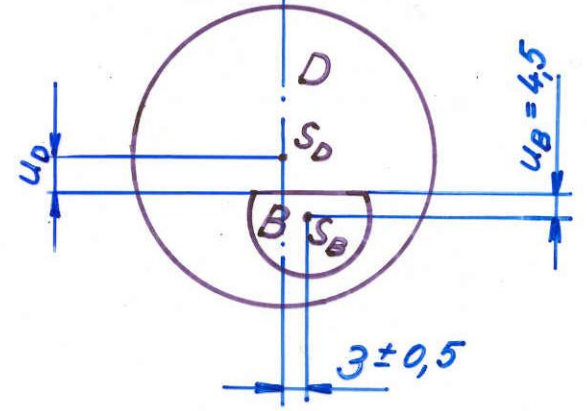

Příklady bifokálních čoček

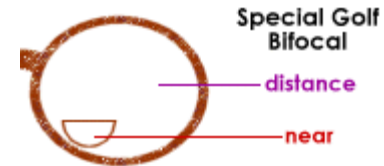
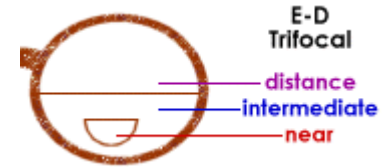
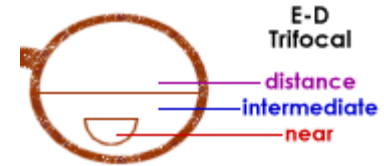
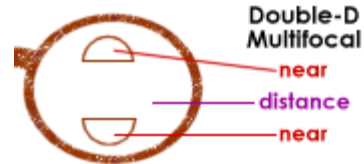
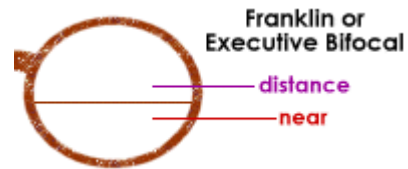
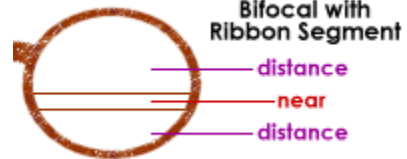
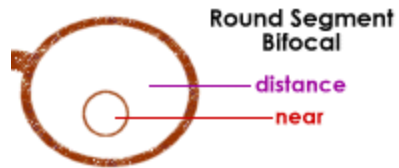
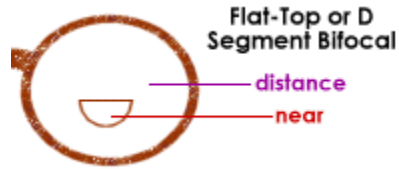

Příklad progresivní čočky

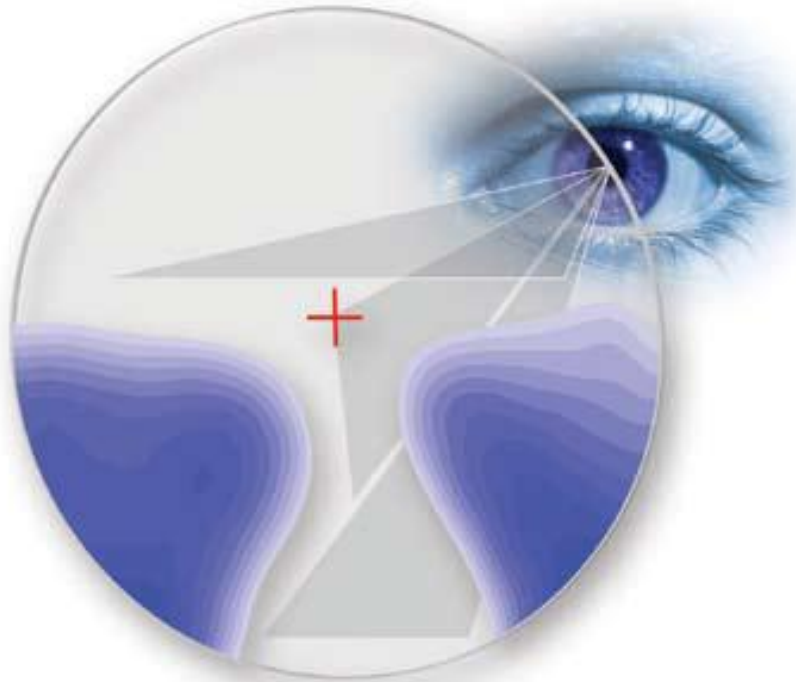

zorné pole do dálky
od 5 m dál



progresivní kanál -
zorné pole na pracovní
vzdálenost 40 cm - 5 m

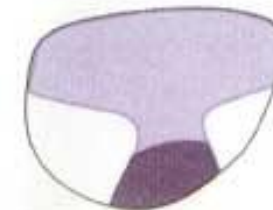

zorné pole do blízka
do 40 cm

Progresivní čočky

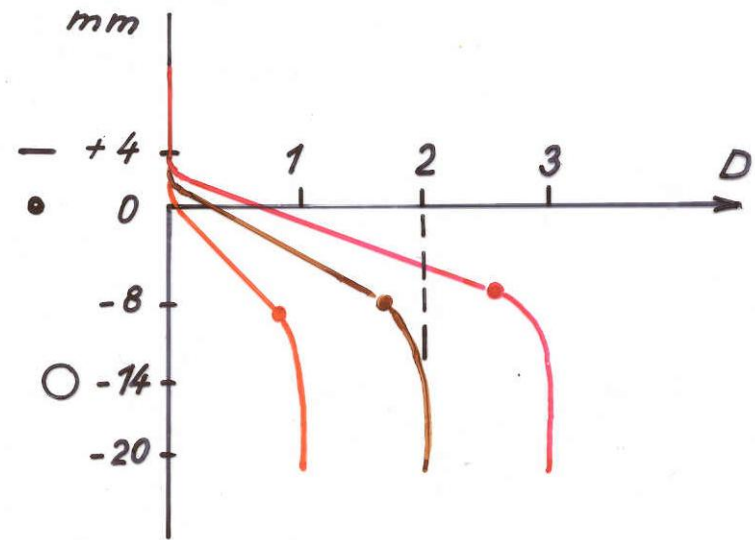
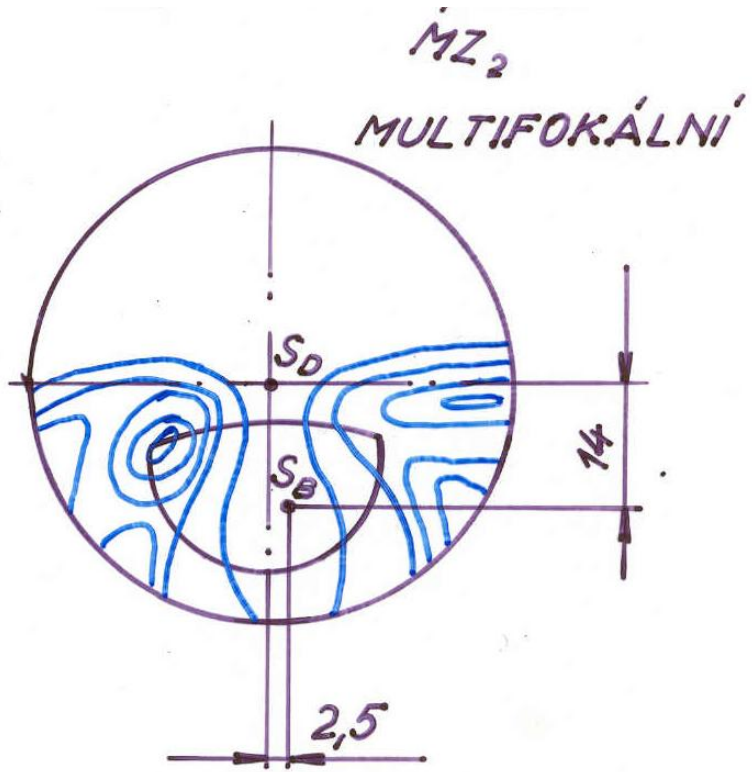

(Varilux comfort)

Progresivní čočky

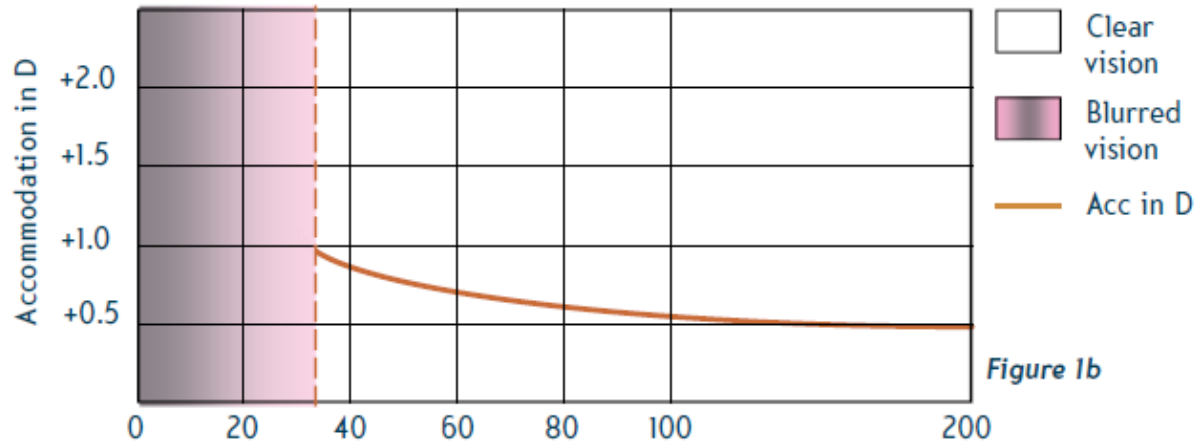
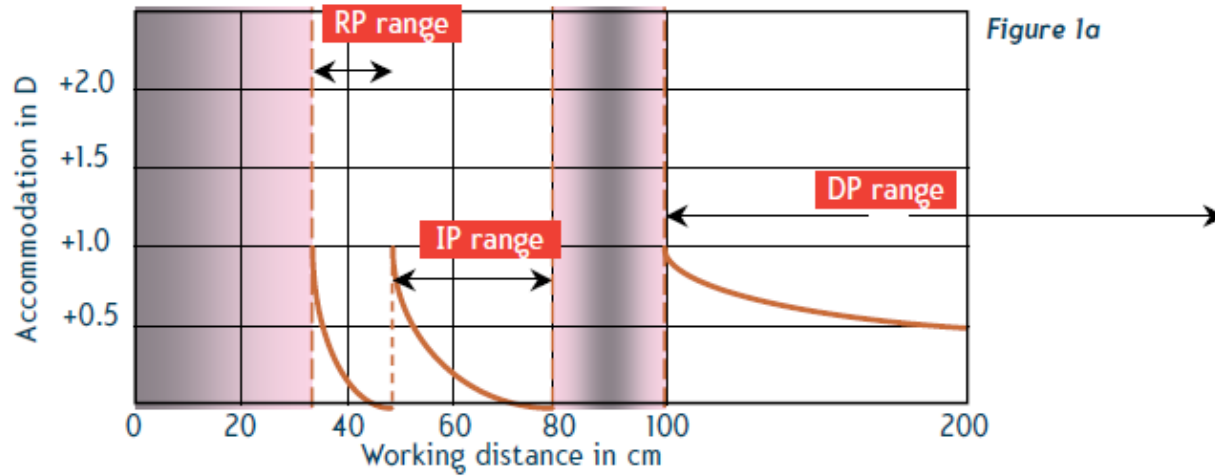

Progresivní čočky

Spherical DP surface

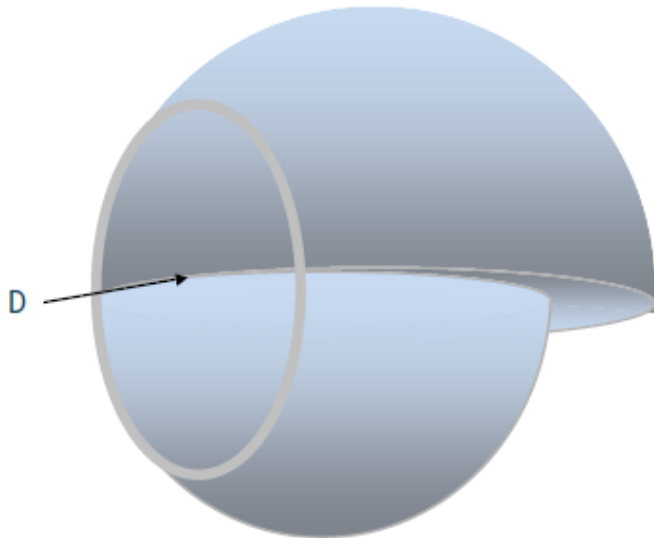

Spherical NP surface

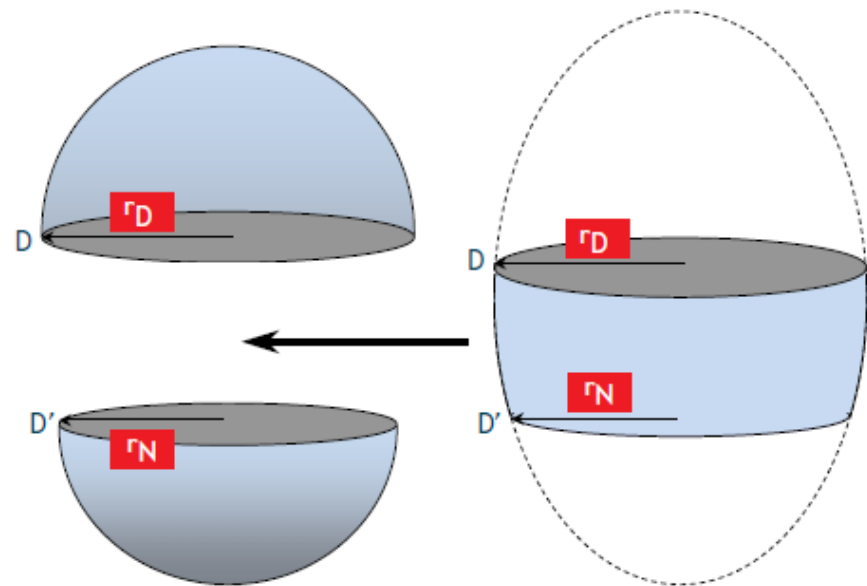

Progresivní čočky

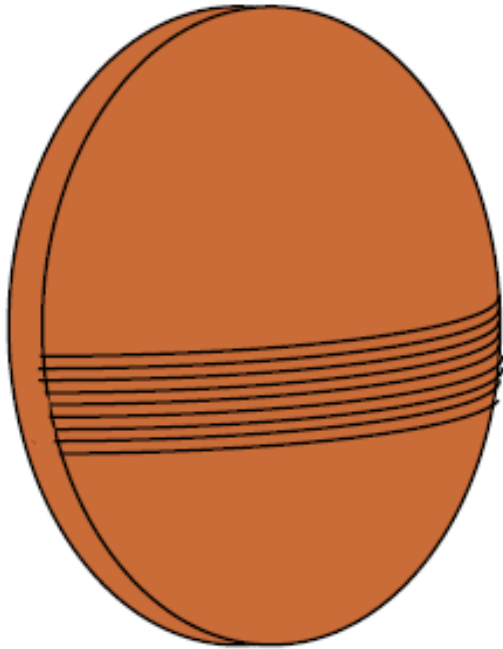

a) Ceramic mould

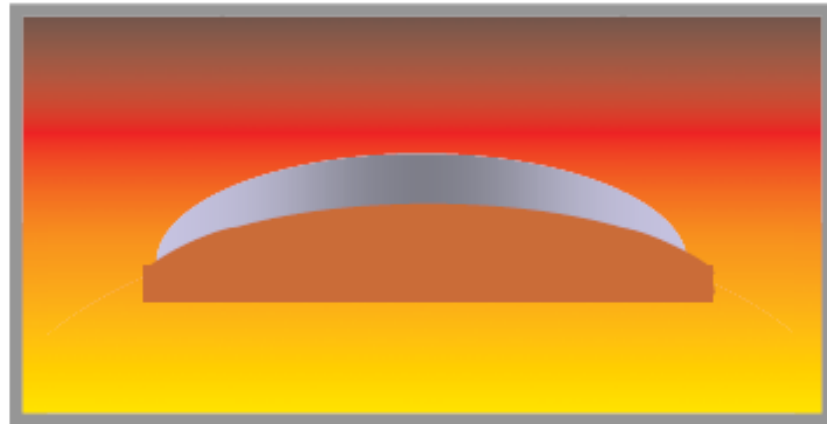

b) Slumping a glass blank (forming)

Progresivní čočky

Field diagrams for spectacle lenses

Tangential and sagittal oblique vertex sphere powers

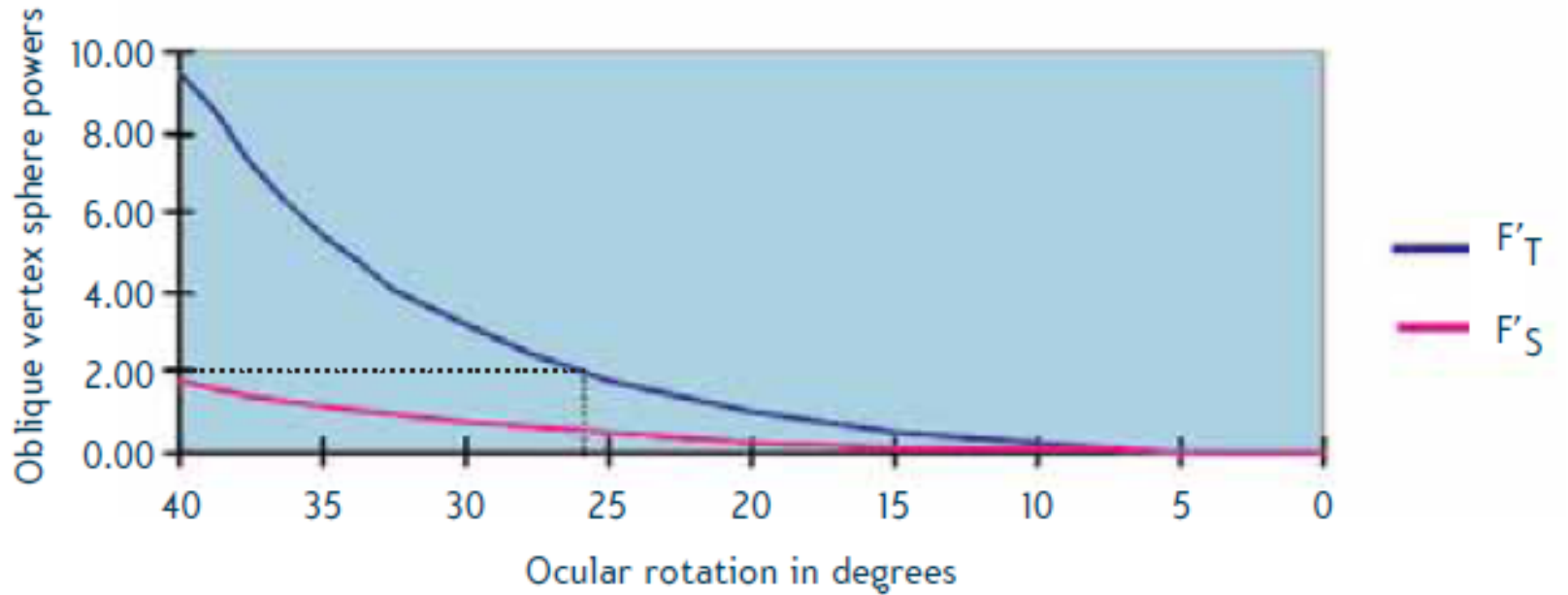

Progresivní čočky

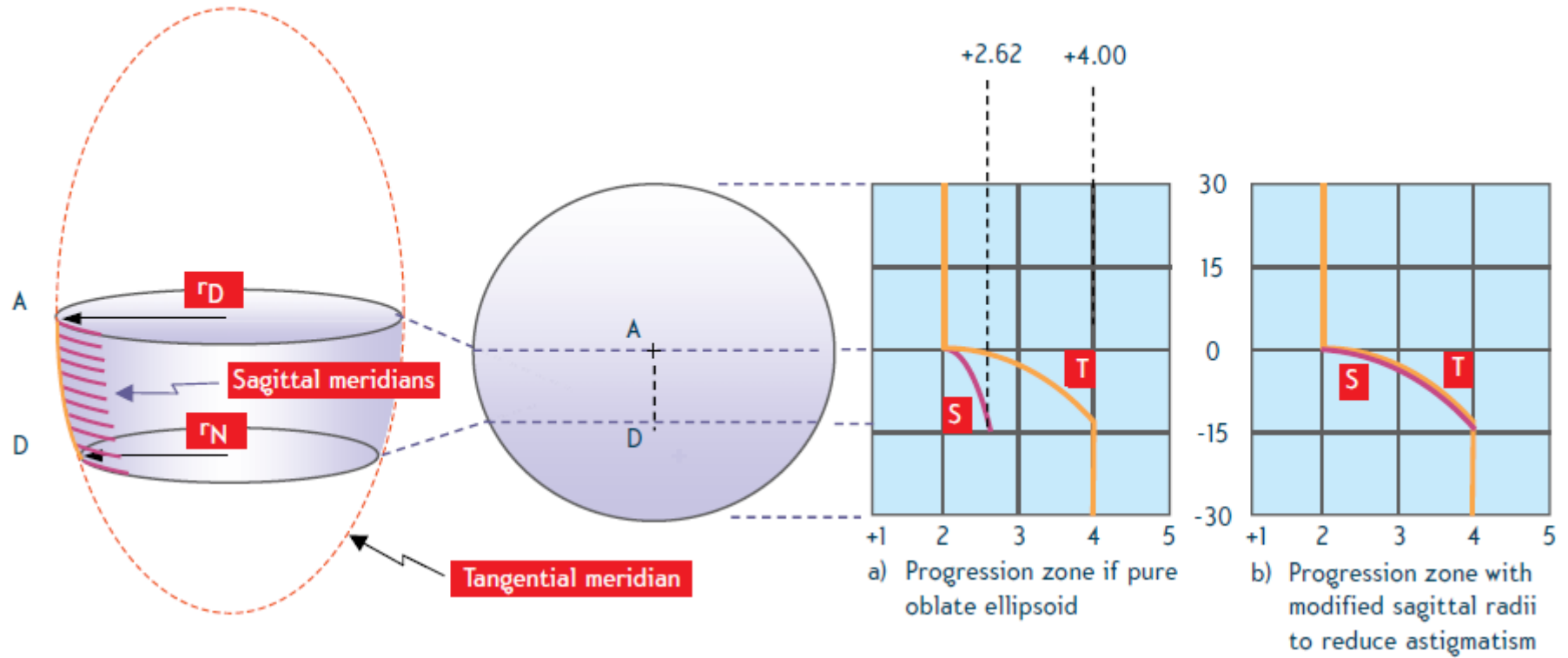

Progresivní čočky

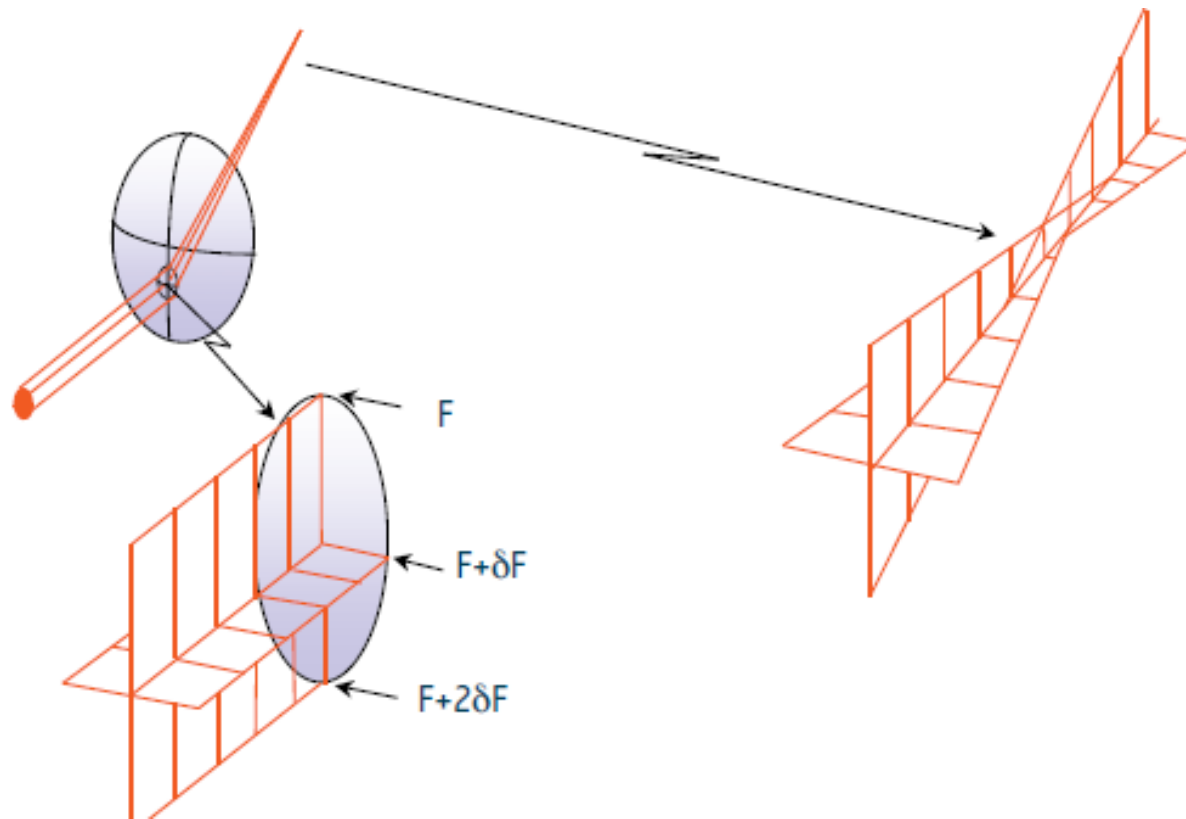

Progresivní čočky

Isocylinder and iso-mean power lines for progressive power lens, plano add +2.00D

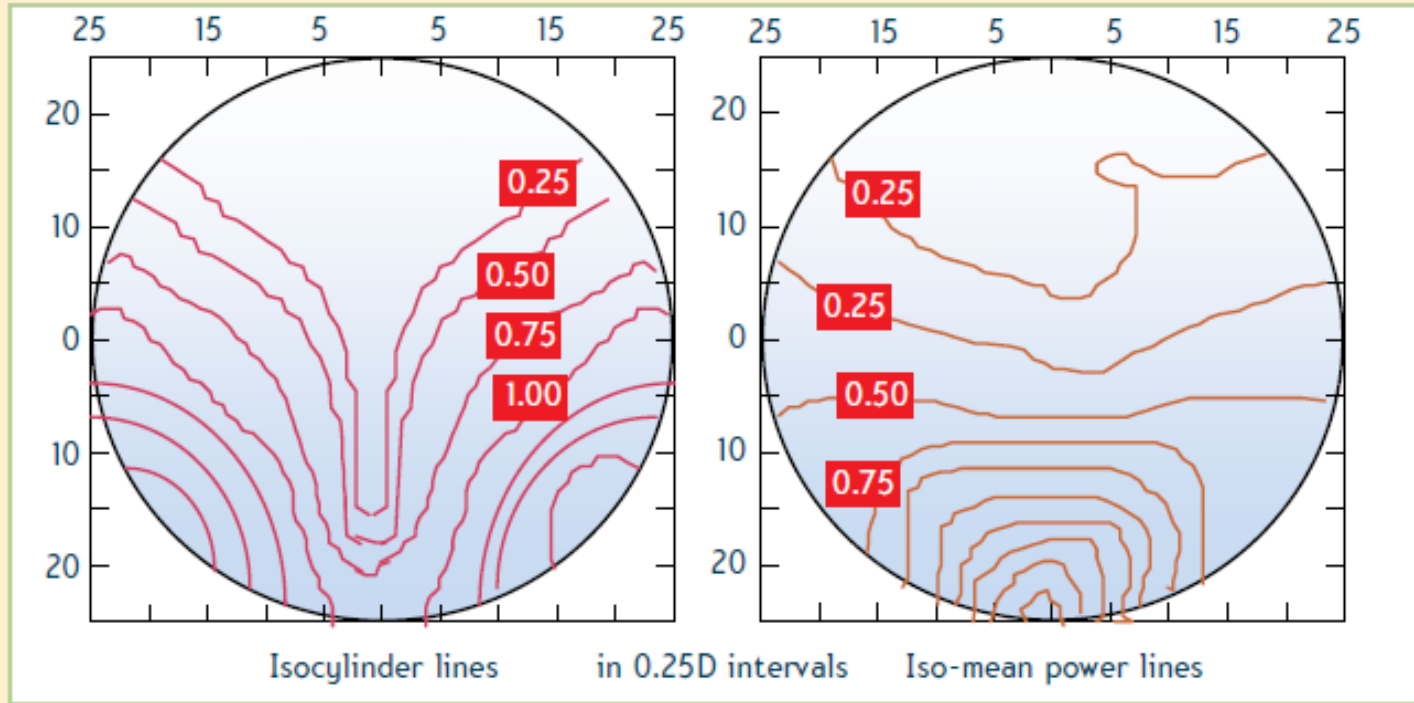

Progresivní čočky

Skew distortion in a progressive power lens

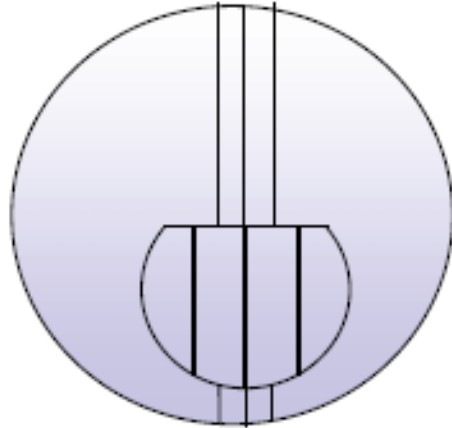

Flat-top bifocal

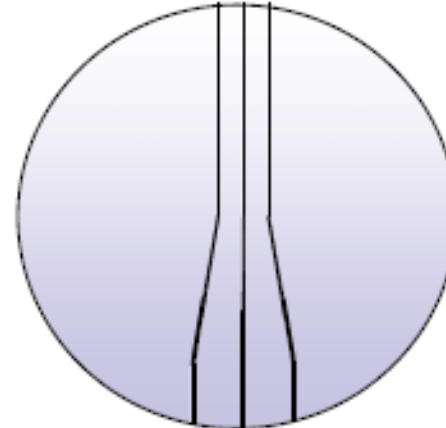

Progressive power lens

Progresivní čočky

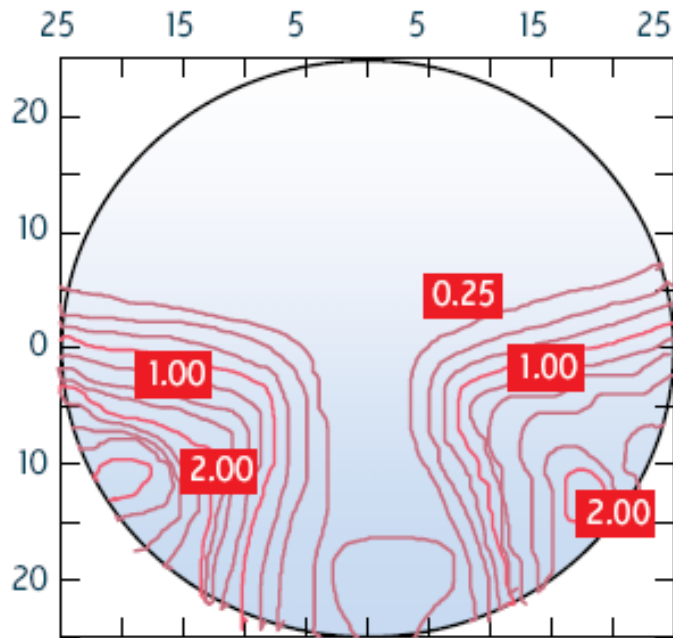

a) Hard progressive lens

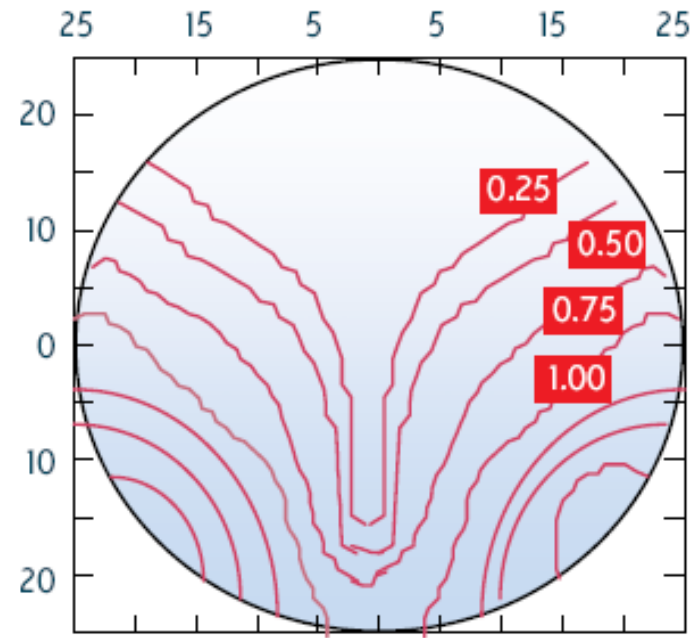

b) Soft progressive lens

Progresivní čočky

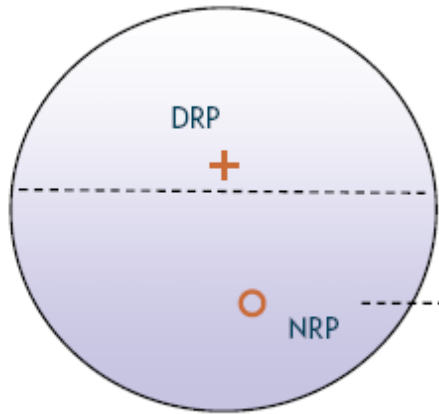

DRP = distance reference point NRP = near reference point

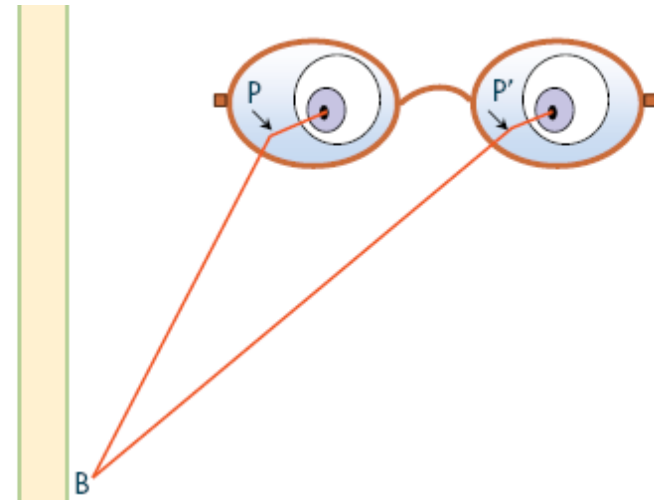
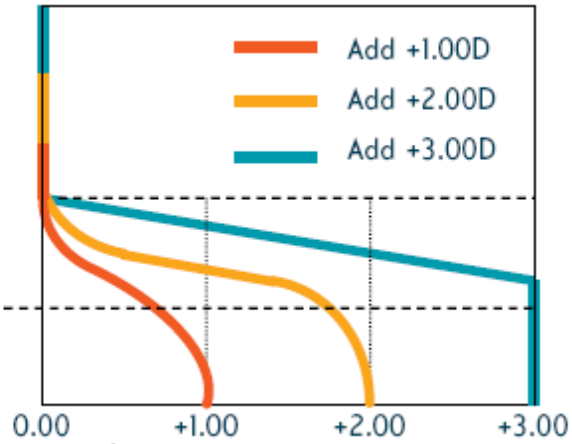

Progresivní čočky

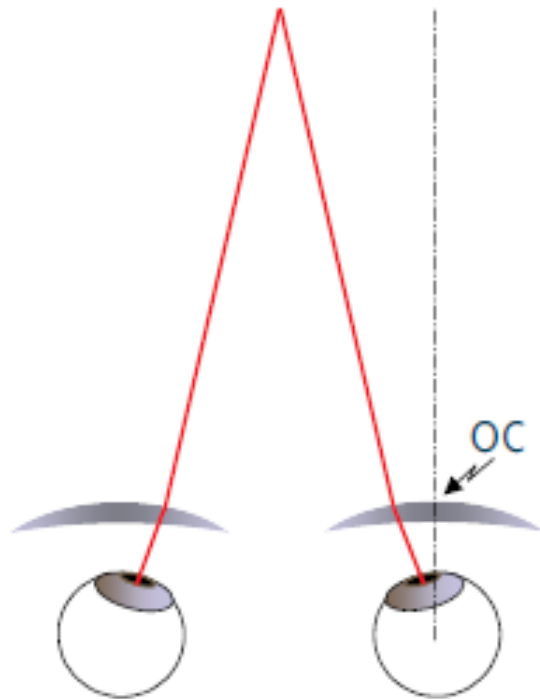

a) Plus lenses

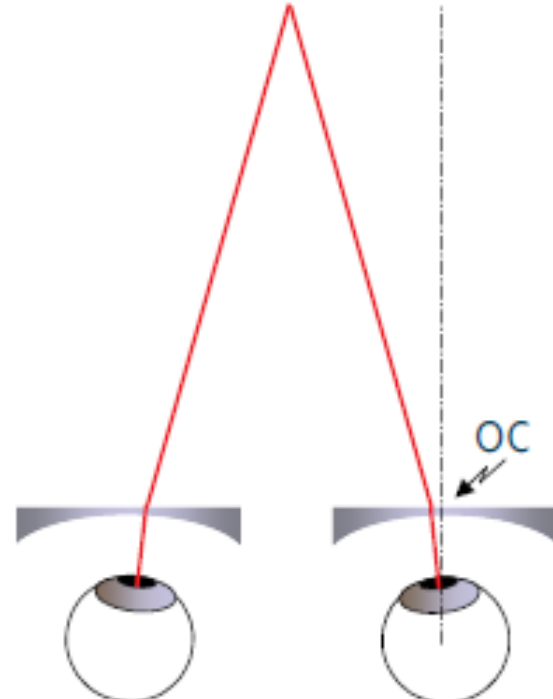

b) Minus lenses