

Electromagnetism

The Foundation Course on Physics

Professor Vojtěch Mornstein

Electromagnetism

- In this lecture, some basic laws about interactions of magnetic fields and current-carrying conductors will be revisited and some newly introduced.
- Good understanding of electromagnetic phenomena is not easy. Electromagnetic field is not visible and has two interconnected components that differ considerably in their properties and also effects: electric and magnetic.
- Electromagnetism is the background of many devices used in medicine and problems addressed also in medical physics/biophysics. Some examples will be introduced.
- General advice: Do not hesitate to ask your teachers if you have a problem: vmornst@med.muni.cz, vbernard@med.muni.cz, and in close future danvlk@med.muni.cz

Magnetic fields

Magnetic fields can be produced by

- 1) permanent magnets and
- 2) by moving electric charge, i.e. by electric current, oscillations of charges etc.!

Magnetic field produced around a straight wire carrying a current

*Each moving electron produces an anti-clockwise magnetic field (B) around itself when viewed along the direction of its motion. However, in the picture below we follow **not the electrons but the current!!!** Direction of the electric current is opposite.*

Magnetic flux density B around an infinite straight conductor (a wire) in vacuum can be calculated according the formula:

$$B = \frac{\mu_0 I}{2\pi d} \quad [\text{T}]$$

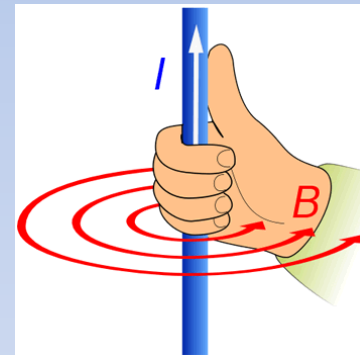

where I [A] is the electric current, d [m] is the distance of a measurement point from the wire. See also Fig. to determine the orientation of the vector \mathbf{B} . „Right hand rule“ – thumb has the same direction as current, curled fingers show the direction of B.

Note: The current is represented by flow of positive charges (based on historical issues of physics). The electrons move in opposite direction.

Magnetic field resulting from a coil carrying a current

A coil or solenoid carrying a current produces magnetic field and behaves similarly to a permanent magnet, N and S poles can be distinguished in them as well.

The following formulas can be derived using complex theory of magnetism. In this theory vector calculus is used in which are defined the directions of vector products. That is why we must use various left- and right-hand rules to find directions of the respective vectors instead of correct mathematics.

2. Magnetic flux density *in the middle* of a circular coil (a simple wire loop):

$$B = \frac{\mu_0 I}{2r} \quad [\text{T}],$$

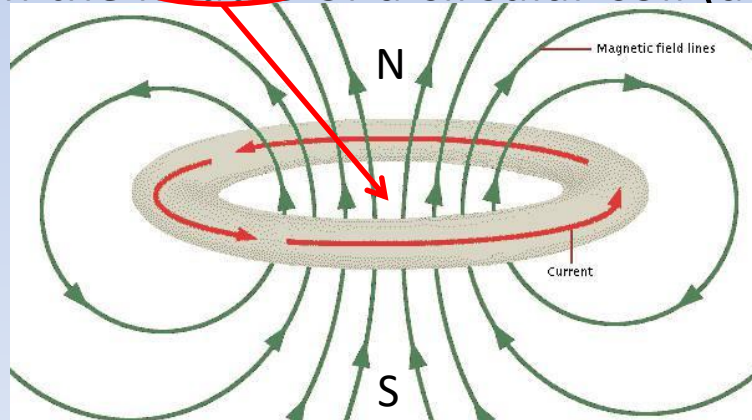

where I [A] is the electric current, r [m] is the radius of the coil.

Multi-layer coil

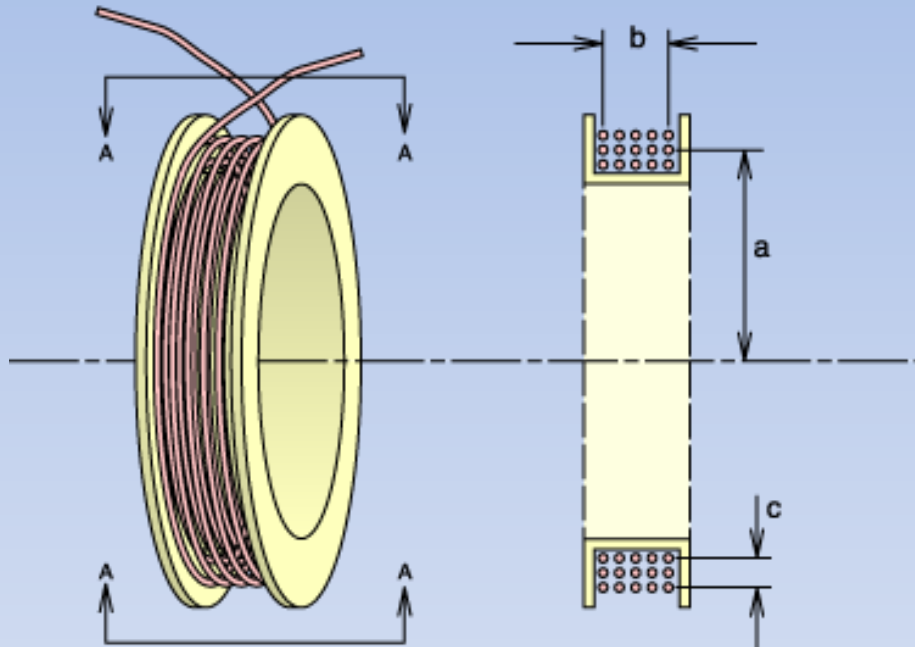

$$B = \frac{N\mu_0 I}{2r}$$

N – number of turns,
 b and c should be very
small in comparison with
the radius of the coil. B is
valid again for the middle
of the coil.

http://info.ee.surrey.ac.uk/Workshop/advice/coils/air_coils.html

Magnetic field resulting from an infinite solenoid carrying a current

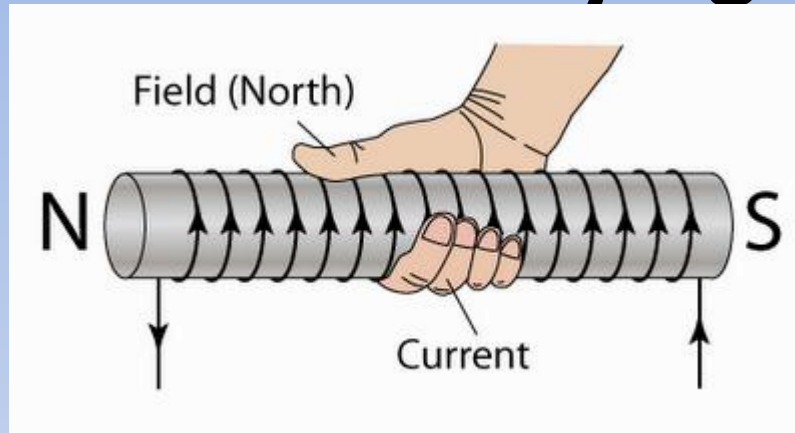

Another „right hand rule“ – the thumb points to the N pole of the solenoid = electromagnet

- 3. Magnetic flux density B inside an infinite solenoid (a long helical coil):

$$B = \mu_0 n I \quad [\text{T}] \quad (\text{vacuum or air within the solenoid) and}$$

$$B = \mu n I \quad [\text{T}] \quad (\text{valid for a solenoid with a core of material having } \mu = \mu_r \mu_0),$$

I [A] is the electric current and n the number of solenoid turns per meter (i.e. $n = N/L$, where N is the total number of turns and L is the length of the solenoid).

Note: there is no dependence on radius! The field inside the infinite (very long, say) solenoid is **homogeneous**.

In Medicine: MRI (Magnetic Resonance Imaging)

The patient is placed in a strong magnetic field produced by a powerful electromagnet. $B = 1$ to 3 T!

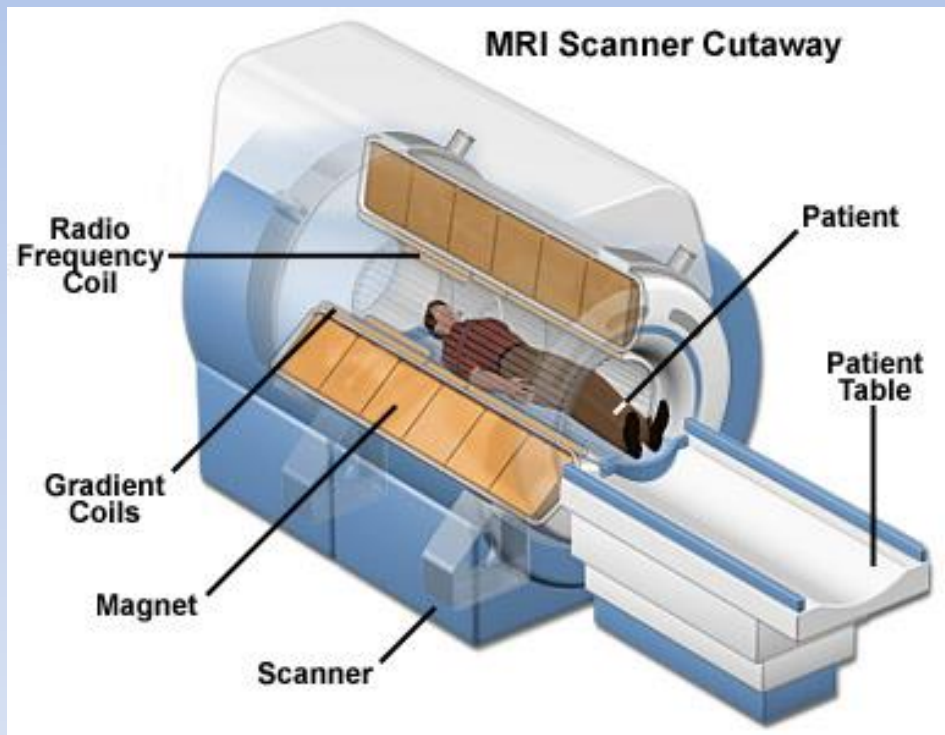

<http://www.biomedresearches.com/root/pages/researches/epilepsy/mri.html>

Enroll in medical faculty - you will get to know more!

Magnetic force on a conductor carrying current

If a straight wire carrying current I is positioned in a homogeneous magnetic field making an angle α with the vector of magnetic flux density B (see Fig. b), the force acting on it can be calculated:

$$F = BL\sin\alpha \quad [\text{N}],$$

where L is the length of the wire exposed to the magnetic field.

Thus, a magnetic flux density 1 T exists if the force exerted on a straight wire of 1 m length is 1 N when the wire carries a current of 1 A and is placed at right-angles to the direction of the magnetic flux B .

To determine the direction of the force exerted: Align one of the externally applied magnetic lines to be **parallel** with and touching one of the magnetic lines produced by the current. The direction from this common point to the conductor gives the direction of force on the conductor. See Fig. c!!!!

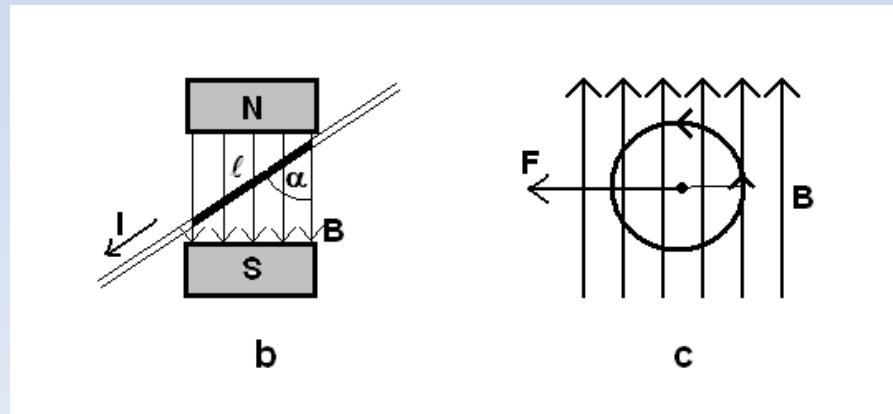

Magnetic force on a conductor carrying current

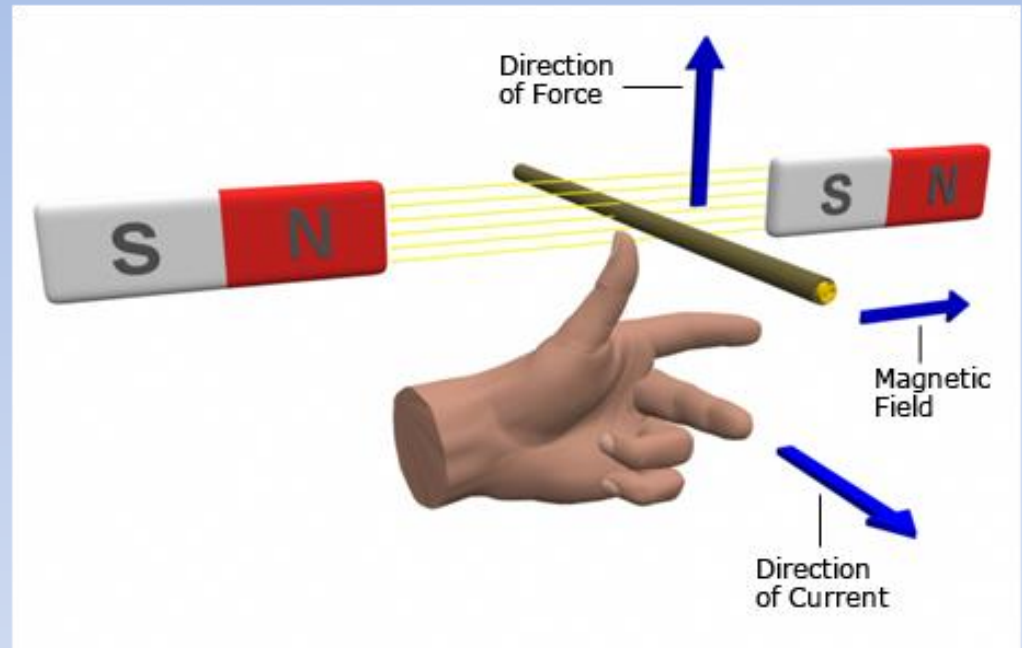

Or: Fleming's Left Hand Rule – compare both methods

Magnetic force between two parallel conductors

The **force per unit length** on wire „B“ (carrying current I_B) due to the magnetic field produced by the current I_A in the wire „A“ is given by:

$$F = \frac{\mu_0 I_A I_B}{2\pi d} \quad [\text{N}],$$

where d is the perpendicular distance between the wires. If the currents have the same direction the wires are attracted. In case they have opposite direction they are repelled. Imagine also a beam of charged particles – what can happen?

Definition of 1 ampere in SI is based on the above formula:

A current of 1 A flows in one infinite straight wire if an equal current in a similar wire placed in parallel 1 meter away in a vacuum produces a mutual force of $\mu_0/2\pi$ N per 1 meter of length (i.e. $2 \cdot 10^{-7}$ N·m⁻¹, since $\mu_0 = 4\pi \cdot 10^{-7}$ N·m⁻¹).

Magnetic deflection of a moving electron/charged particle

The force on an electron (or other particle) with charge e travelling at velocity v at an angle Θ (capital theta) between the velocity and a magnetic flux density B is given by:

$$F = Bev\sin\Theta \quad [\text{N}].$$

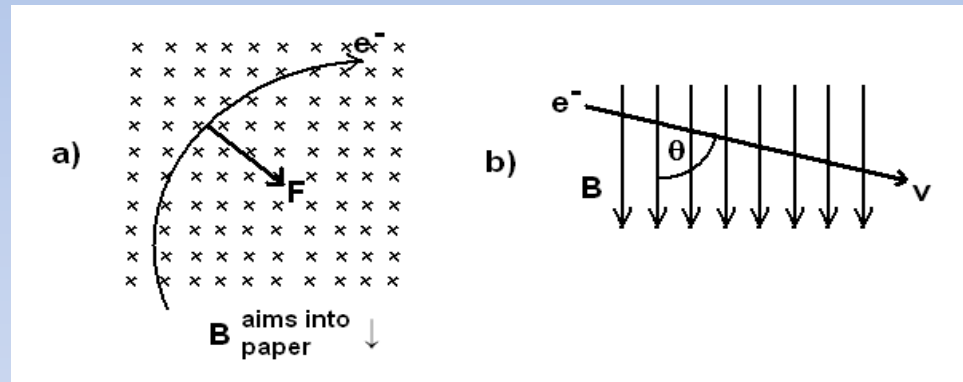

To determine the direction of this force we can use the same rule like for the force exerted on a wire carrying electric current because the moving electron represents also an electric current (flowing in opposite direction compared with conventional direction of current).

Deflection of moving electrons/charged particles by magnetic field is exploited e.g. in electron microscopes, mass spectrometers (see Glencoe pp. 706-707) and some accelerators.

Electromagnetic induction

Voltage induced in a straight wire

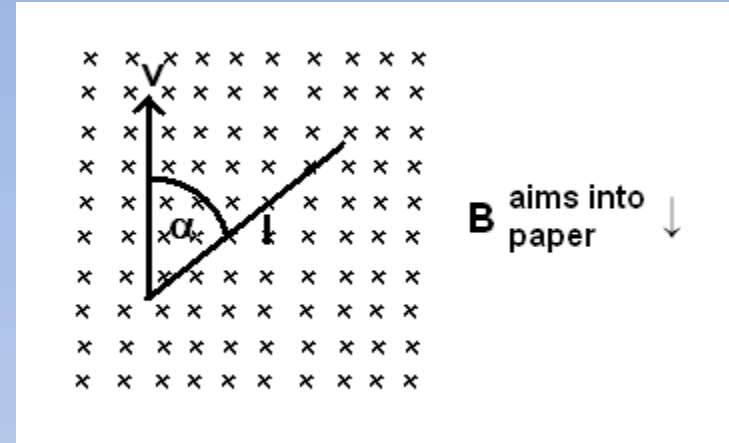

Voltage induced across two ends of a straight wire moving in magnetic field \mathbf{B} is given by:

$$V = \mathbf{BLv}\sin\alpha \quad [\text{V}],$$

where L is the length of the conductor (wire) [m], v is the velocity of the conductor [$\text{m}\cdot\text{s}^{-1}$], and α is the angle between \mathbf{v} and the wire. We assume that the vector \mathbf{v} and the wire are perpendicular to \mathbf{B} . If not, we have to calculate with their components lying in the plane perpendicular to \mathbf{B} (\mathbf{B} is the plane of this page). See also Fig. : A wire moving in magnetic field. L is the length of the wire (a conductor), v is its velocity.

Electromagnetic induction

Voltage induced in a solenoid

In general, electromagnetic induction is the production of an electric voltage (and hence a current) in conductors due to a changing magnetic field. It is described by the **Faraday's laws**:

A change of the magnetic flux linked with a conductor induces an electromotive force (voltage) in the conductor.

The magnitude of the induced electromotive force is proportional to the rate of change of magnetic flux linkage

The “linkage” is the

number of force lines intersected by the moving conductor
or

the product of the change of magnetic flux $\Delta\Phi$ and number of turns in a solenoid N . (For a single wire loop $N = 1!$)

Electromagnetic induction

For the induced voltage V we have:

$$V = - \frac{\Delta\Phi N}{\Delta t} \quad [\text{V}],$$

where $\Delta\Phi N$ is the change of magnetic flux linkage, Δt the time of change, and N the number of turns in a solenoid.

Lenz's law: *The direction of the induced current in a conductor caused by a changing magnetic flux is such that its own magnetic field opposes the change in magnetic flux. (That is why there is the „-“ sign in the above formula.)*

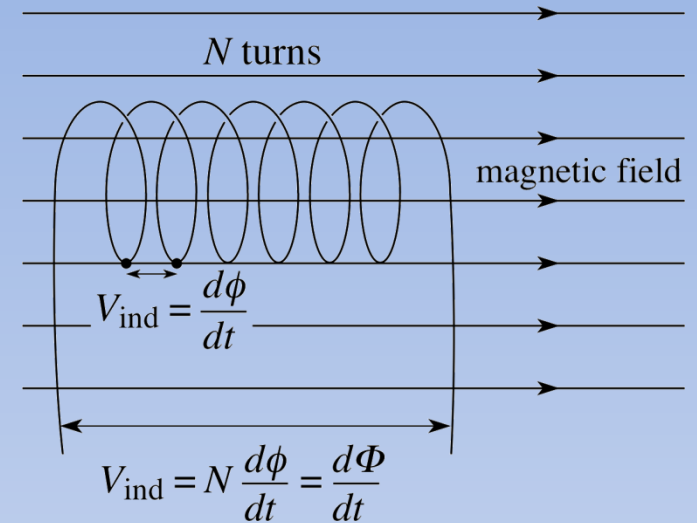

Self-inductance

A change of current through a coil induces a voltage which acts against the current change. Voltage appears both at increase or decrease of the current.

Voltage induced by change of current in a solenoid:

It is given by the formula:

$$V = L \frac{\Delta I}{\Delta t} \quad [\text{V}]$$

where L^* is the **self-inductance** of the solenoid and

$$L = \mu \frac{N^2 A}{l} \quad [\text{H} - \text{henry}]$$

In the last formula, N is the number of solenoid turns, l is the *length of the solenoid* [m], A is the cross-sectional area of the solenoid [m²], and μ is the permeability of the medium inside the solenoid.

*not length of a wire!!!!

Self-inductance

Sudden interruption of a current flow through a solenoid produces a high voltage impulse that demonstrates as a spark!

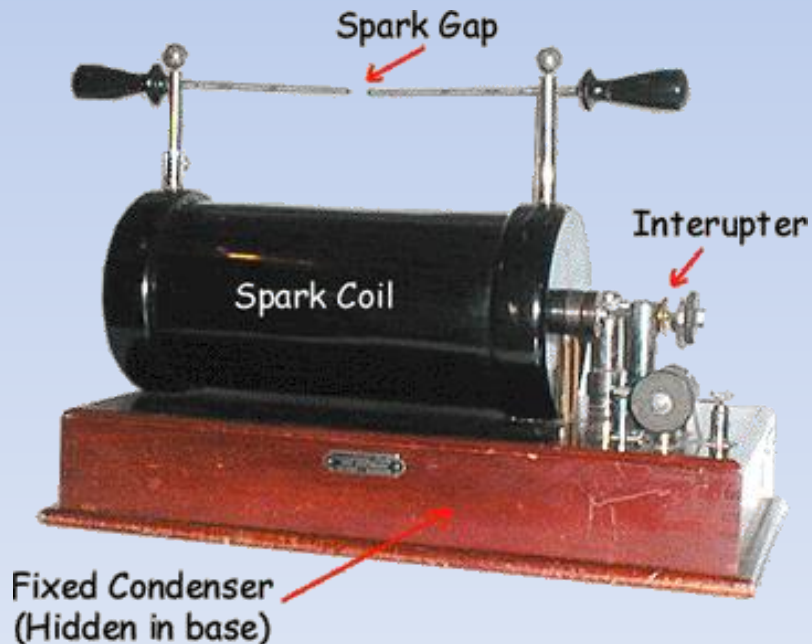

This is also the principle of ignition coil that is connected to spark plugs in a car combustion motor. Gasoline aerosol is ignited by the electric sparks.

Electromagnetic induction: where to find it in practice? Everywhere!

Few examples:

Wireless transfer of electric energy – even into implants inside the body

Induction heating plates

Induction heating of tissues – diathermy

Production of electricity (alternating current)

Melting metals

Transformers (next lecture)

..... Etc. , etc., etc.

Safe recharging of an electric toothbrush or wireless chargers for smartphones!!!!

Wireless transfer of electric energy – even into implants inside the body



Cochlear implants

While hearing aids can only amplify sound, a cochlear implant transforms sound into electrical energy that is used to stimulate auditory nerves in the inner ear.

1 Sounds are picked up by a microphone that is mounted on the external ear piece.

2 The speech processor digitizes the sound into signals and sends the signals to the transmitting coil.

Controls for processor are on the bottom of ear piece.



3 A transmitting coil sends the coded signals as radio waves to the cochlear implant under the skin.

4 The internal processor is placed in the mastoid bone behind the ear. The cochlear implant delivers electrical energy to an array of electrodes, which has been inserted into the cochlea.

5 The electrodes along the array stimulate the remaining auditory nerve fibers in the cochlea.

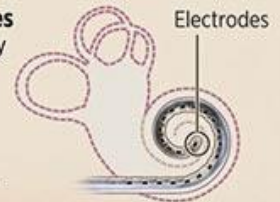

6 The resulting electrical sound information is sent through the auditory system to the brain.

Induction heating plates



Iron pots are heated,
nothing else!

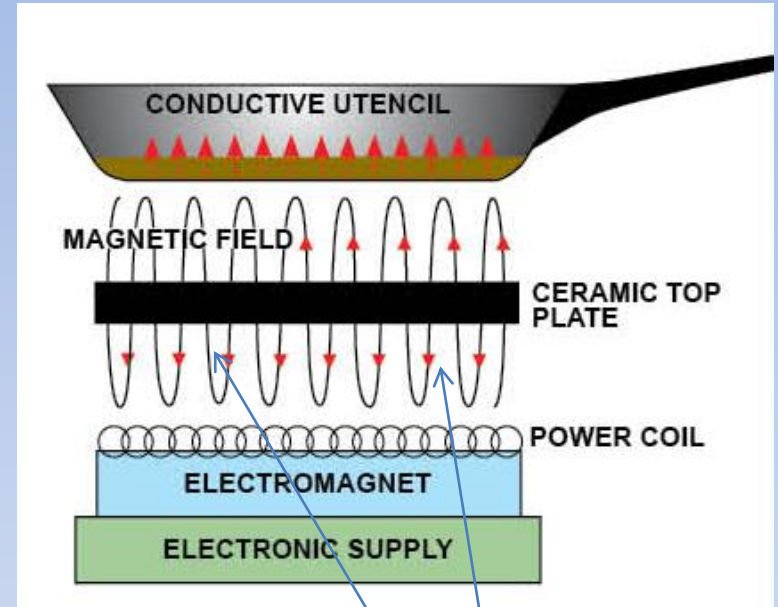

This magnetic field
looks rather bizarre!
It doesn't matter 😊.



20 kHz

diathermy

B) Inductive application

Based on (electromagnetic induction)
Use induction coils that apply a magnetic field to induce circular electrical field in the tissue.
They achieve higher temperature in water-rich tissues. (Like: ms. Skin. Blood ..etc.)

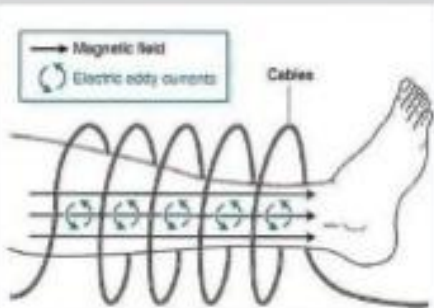
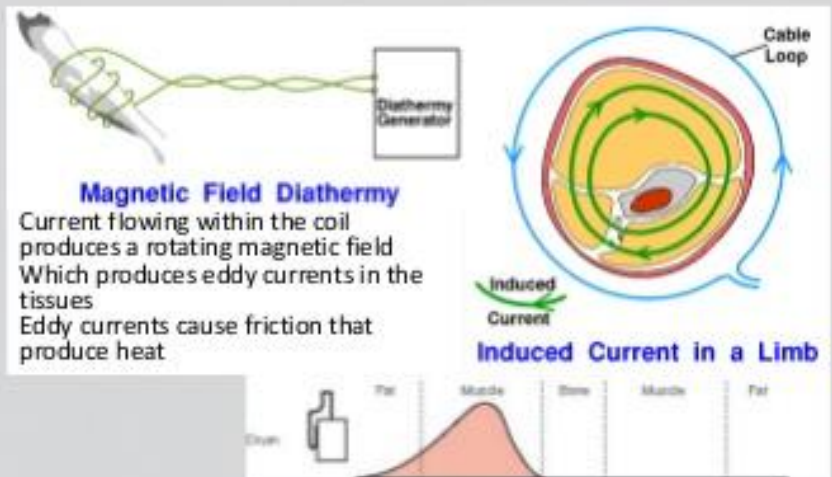

Eddy currents

Compact coil applicator



Production of electricity

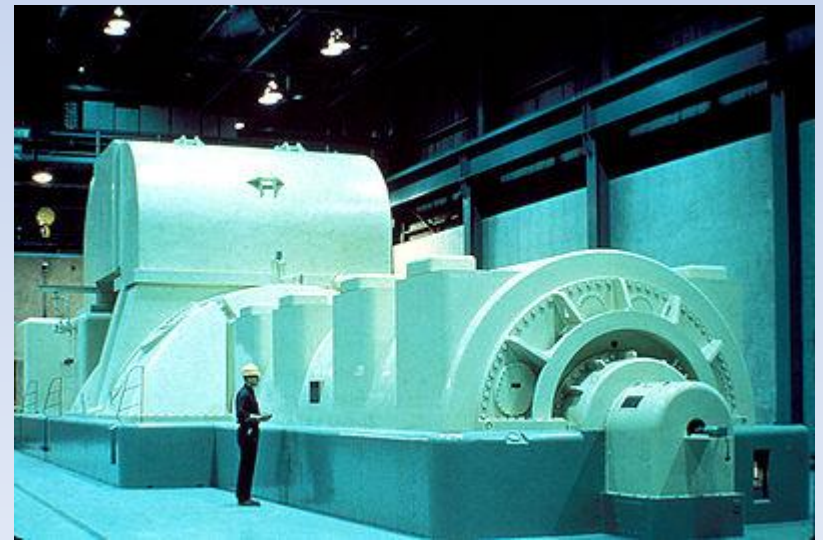
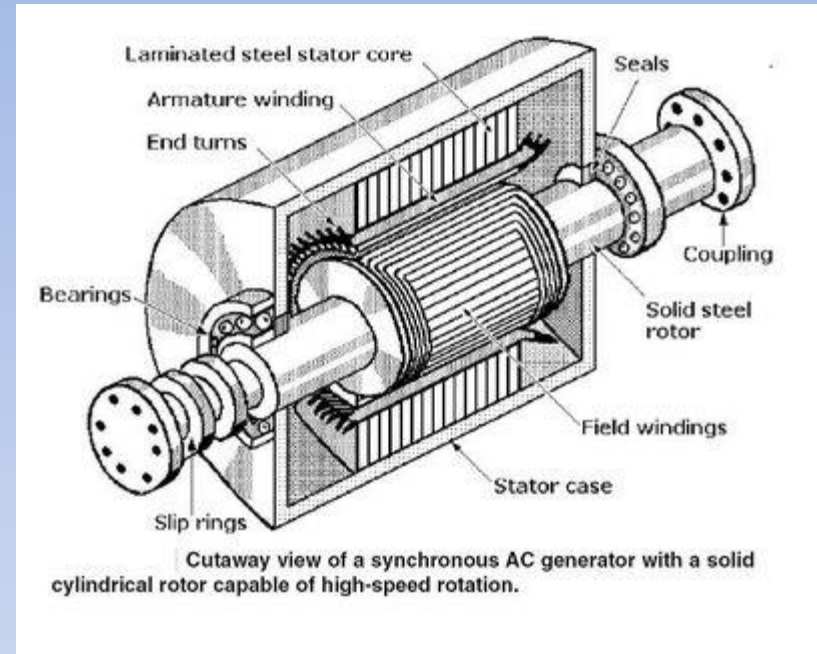
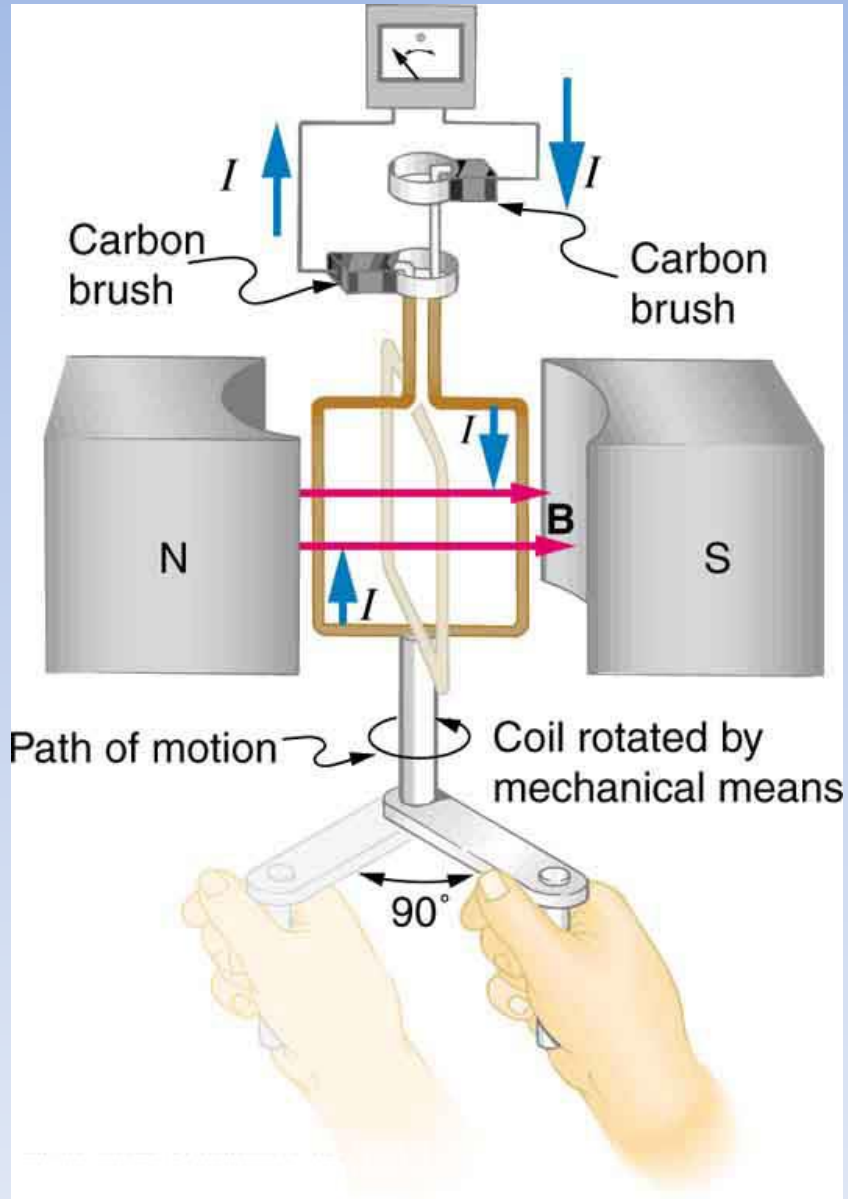

Melting metals by induction



gold



platinum



titanium

Electric toothbrush charging

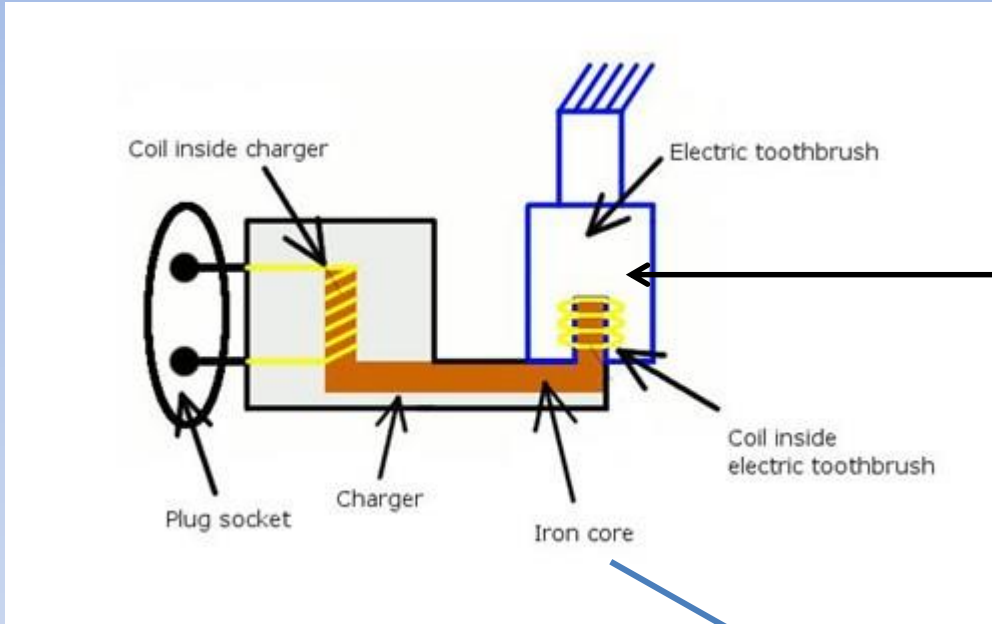

Battery can be charged



Wireless Chargers for Smartphones

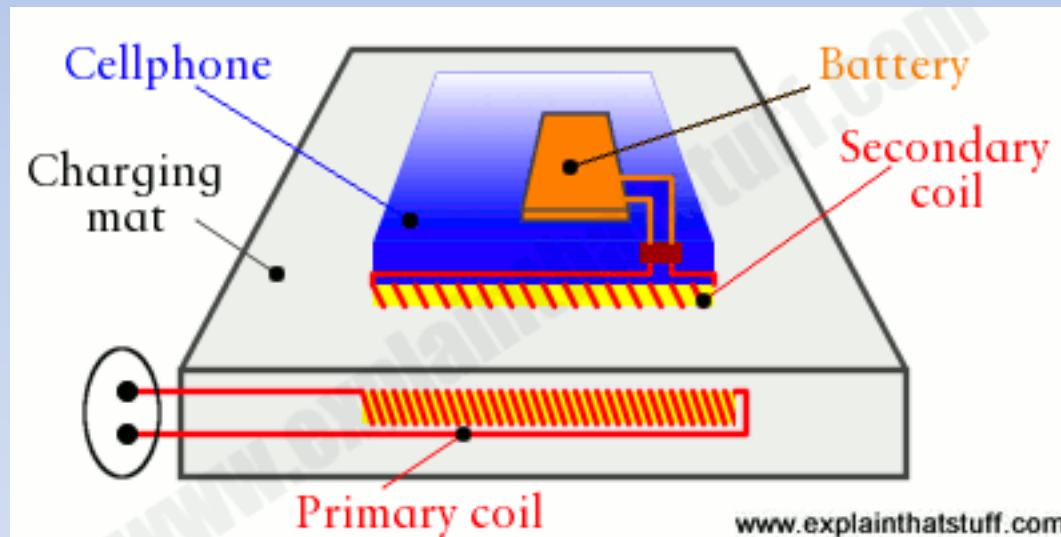

Battery can be charged



Electric joke

Guide to Fuse Replacement

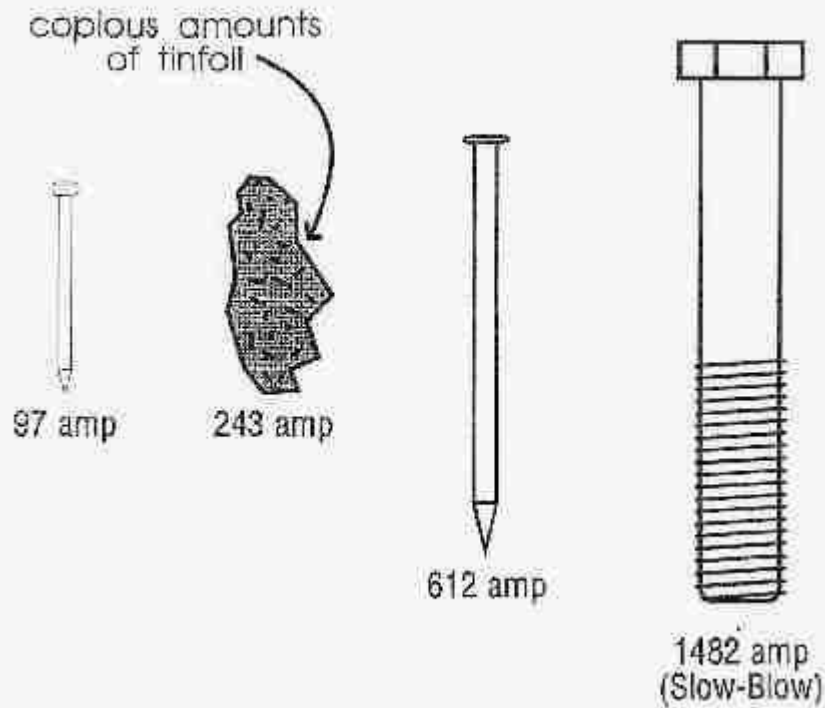

February 2020