

# Dějiny Řecka I. seminář

## 4. TÉMA OLYMPIE A OLYMPIJSKÉ HRY



**Greece and the Aegean during the Dark Ages (12th – 9th cents. BC); the most important sites**

- |   |   |                                     |
|---|---|-------------------------------------|
| ● Important settlement                            | Chronology:   | Finding - places of imported goods: |
| ○ Settlement (with / without architectural finds) | ▨ Late Helladic (12th / early 11th cents.)                | ┃ Orient                            |
| ⌂ Necropolis / tomb                               | ▤ Sub - Mycenaean / Sub - Minoan (early - mid 11th cent.) | ⌘ Cyprus                            |
| ⌂ Sanctuary                                       | ▥ Proto - geometric (mid 11th cent. – c. 900 BC)          | ⌚ Italy, Europe                     |
| ⌂ Centre of pottery production                    | ▧ Geometric (Early, Middle) (9th – early 8th cents.)      | Mykenai Ancient name                |
| ? ⌂ Identification uncertain                      | ▩ Dating certain / uncertain                              | Çömlekçi Modern name                |
|   |   | (Rhodos) Island                     |





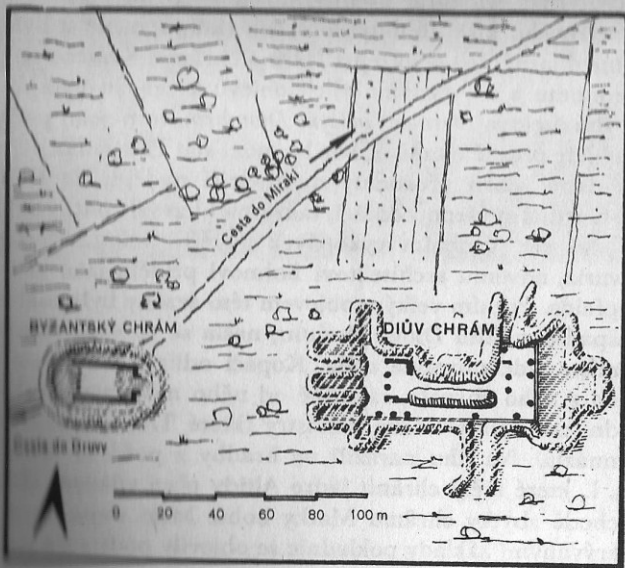

*Vykopávky v Olympii.  
Vlevo stav po  
francouzských výkopech  
roku 1829, vpravo po  
dvou sezónách  
německých výkopů roku  
1887. Poloha stadiónu  
a jiných sportovních  
staveb nebyla tehdy ještě  
známa*

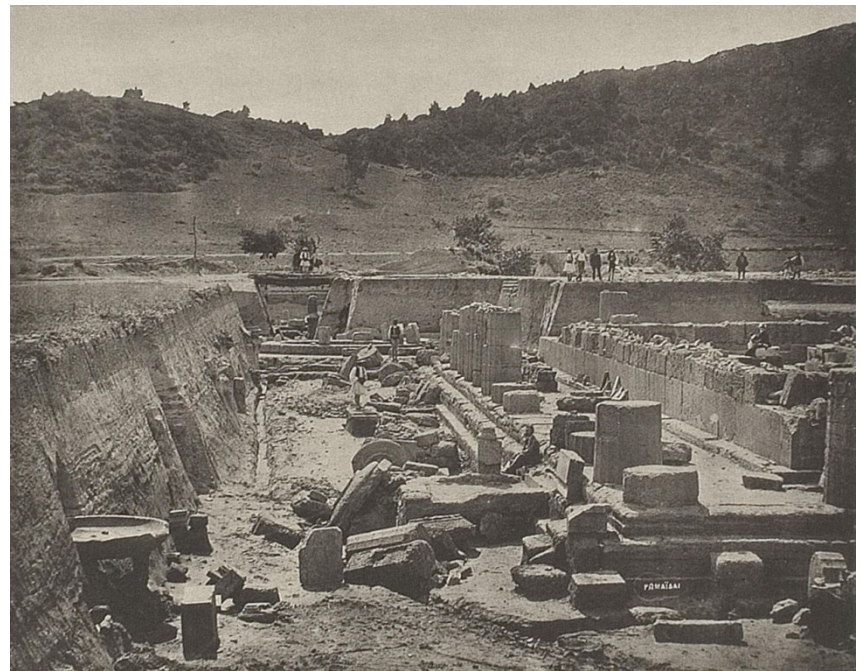
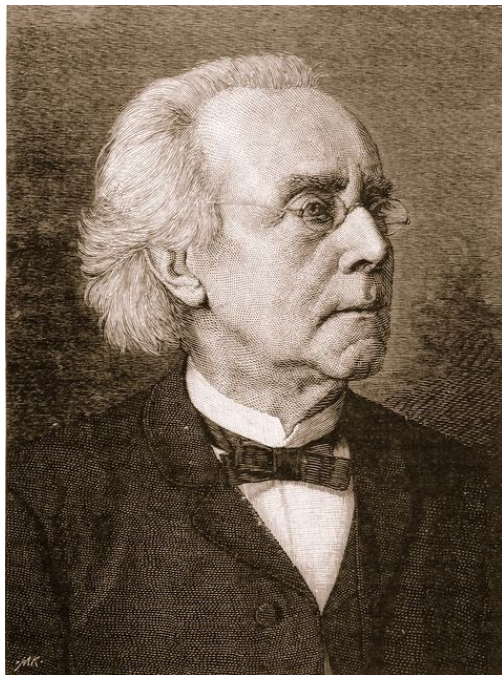
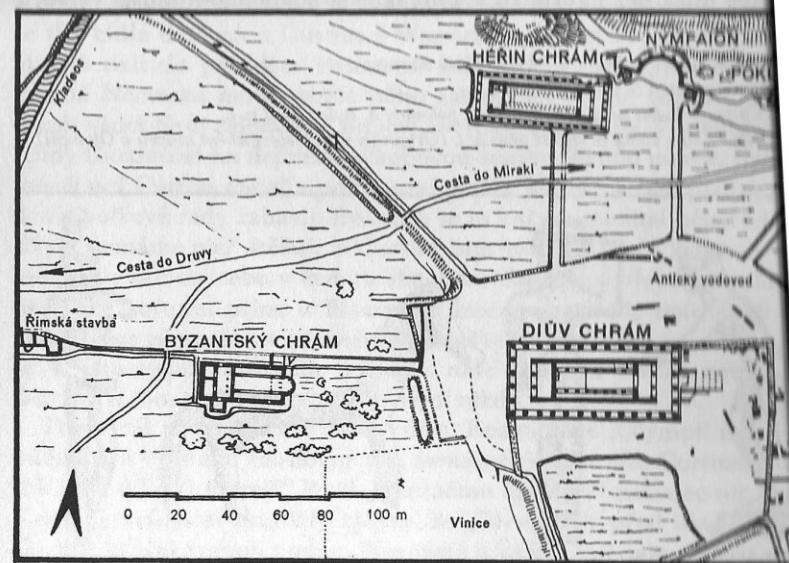



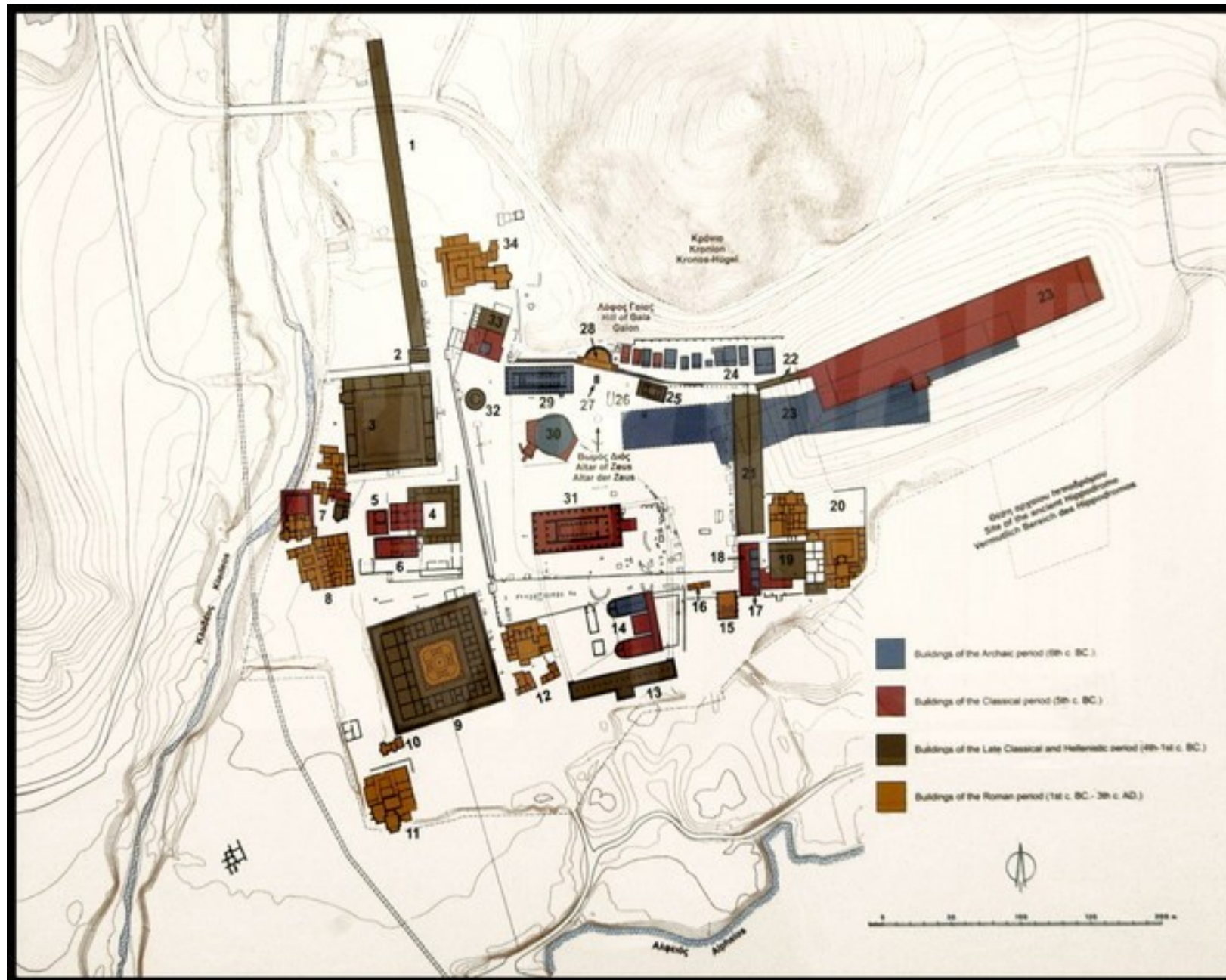

- 1. Gymnasium
- 2. Propylon
- 3. Palaestra
- 4. Theokleion
- 5. Heron
- 6. Pheidias' workshop
- 7. Kladeos baths
- 8. Roman Guest Accomodation
- 9. Leonidion
- 10. Ἰατρικὸν Ἀστυνόμιον
- 11. SW Baths-Athlet's Club
- 12. Southern Baths
- 13. Southern Colonnade
- 14. Bouleuterion
- 15. Odeion
- 16. Arch of Nero
- 17. Sanctuary of Hestia
- 18. SE building
- 19. Greek Building
- 20. Octagon
- 21. Echo Colonnade
- 22. Krypte
- 23. Stadion
- 24. Treasuries
- 25. Metroon
- 26. Prehistoric apsidal building II
- 27. Altar of Hera
- 28. Nymphaion
- 29. Herain
- 30. Pelopion
- 31. Temple of Zeus
- 32. Philoppeion
- 33. Pnythaeion
- 34. Building of a Roman House





*An aerial view of Olympia, Greece*







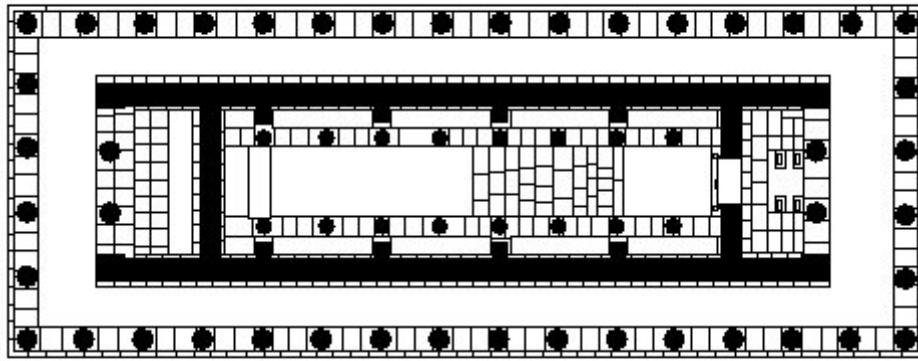

0 1 10 m. ↑











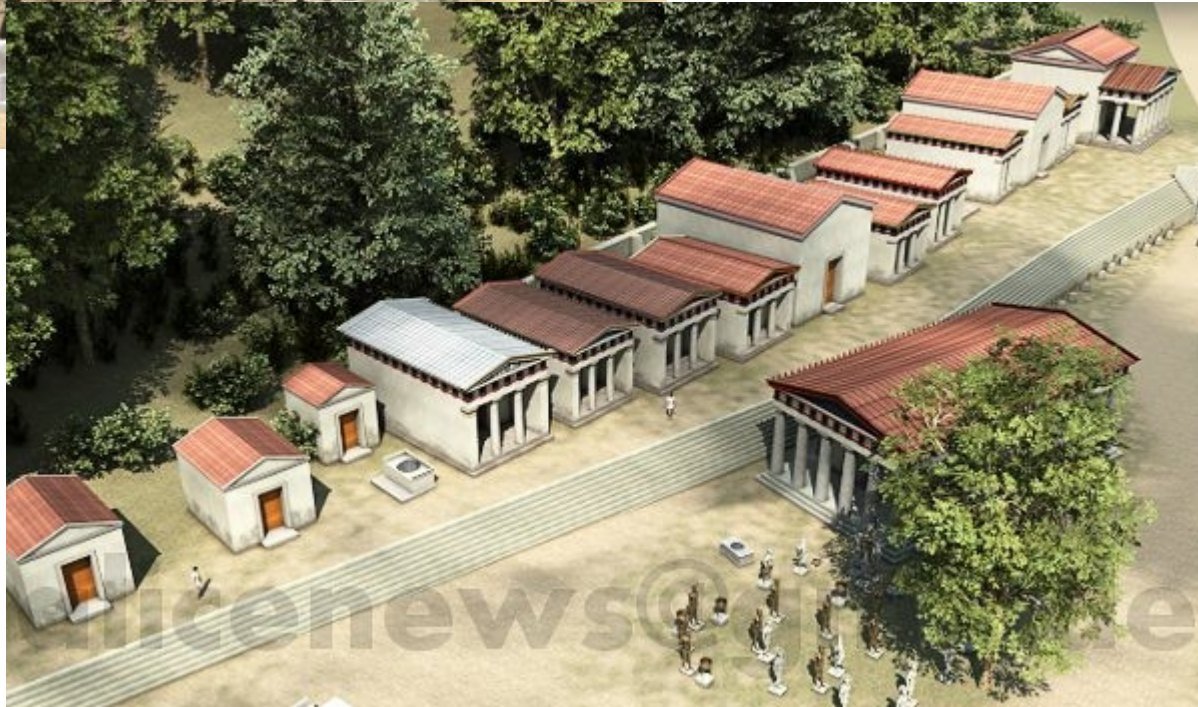
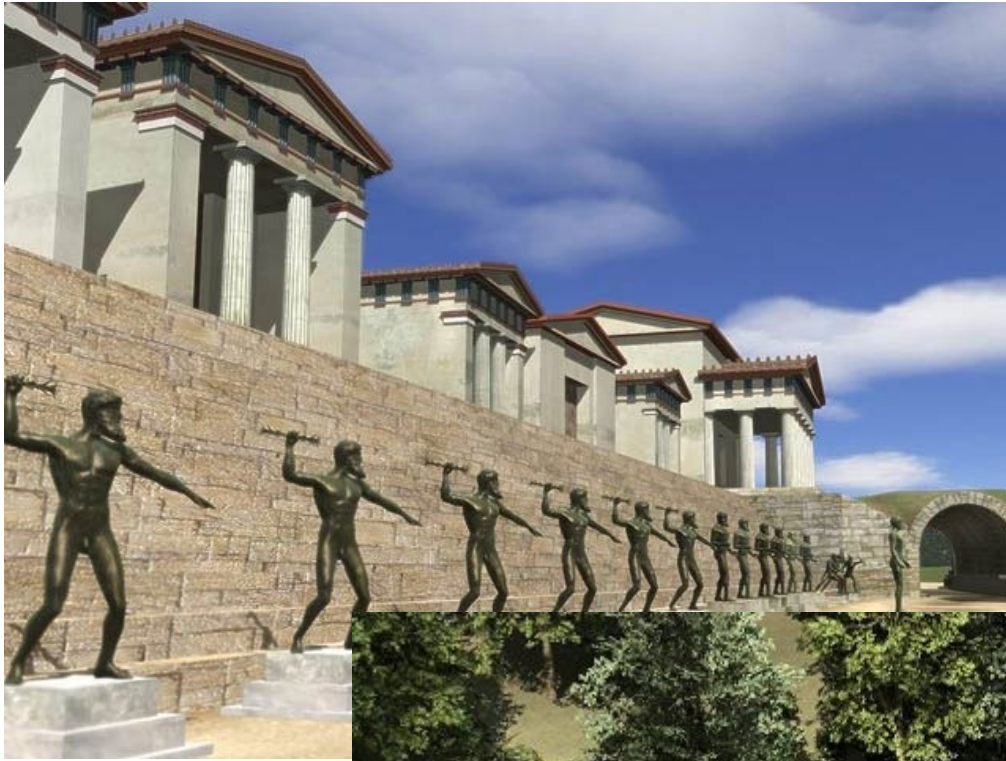



Olympia, Pelopeion

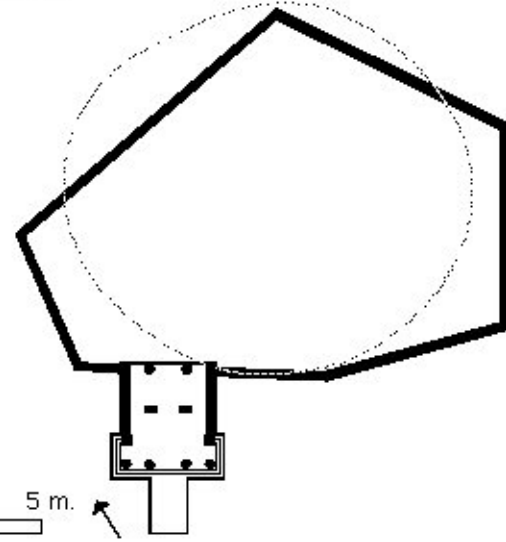
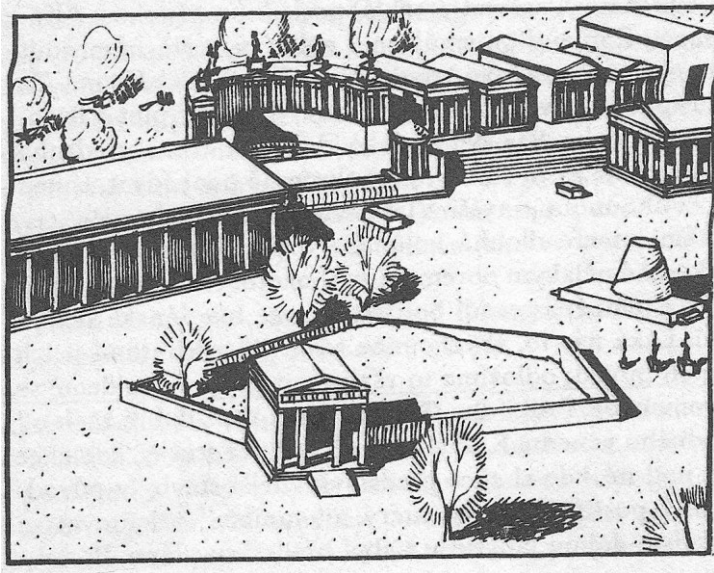





# Olympia, Bouleuterion

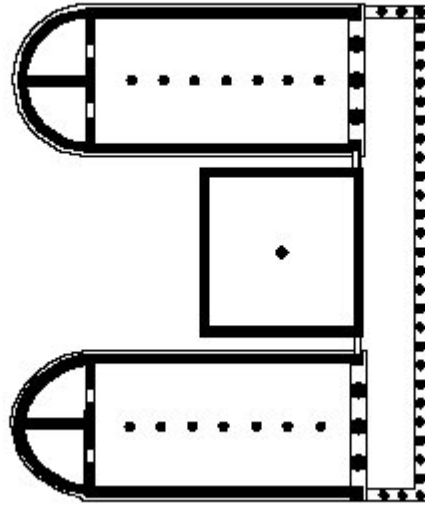

0 10 m.  



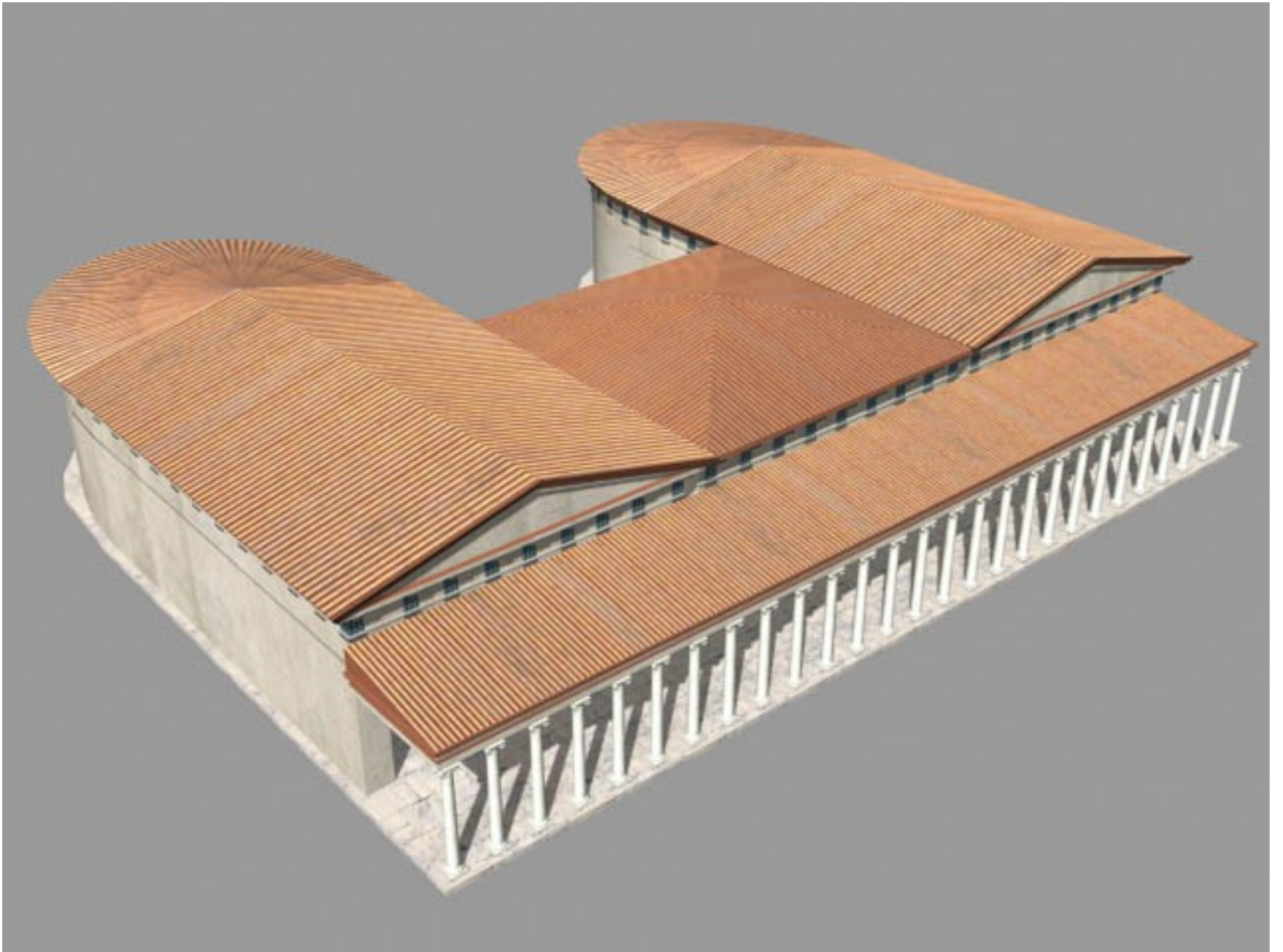



# Olympia, Temple of Zeus

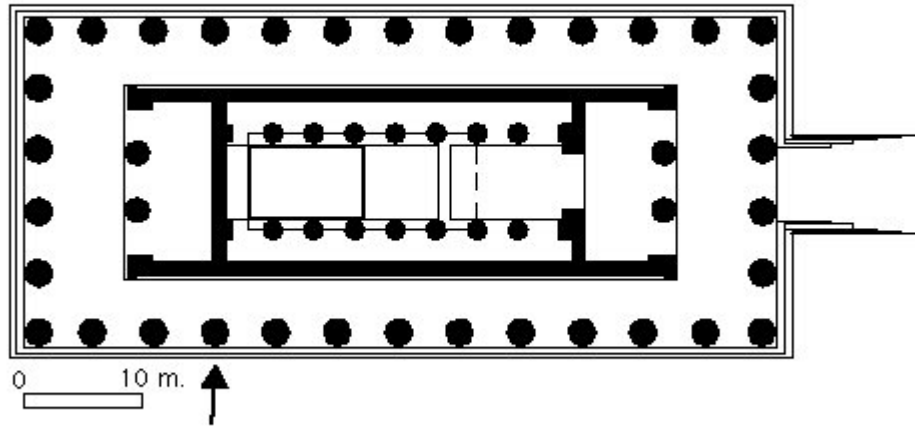







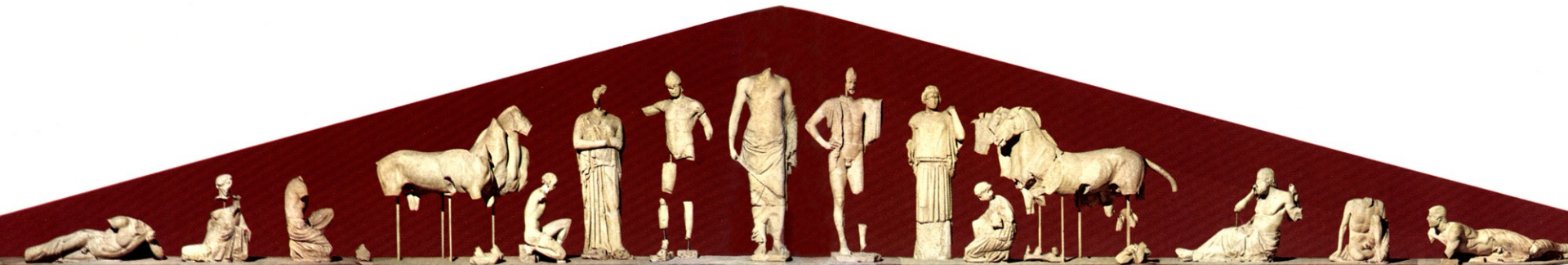

*Alpeios or Kladeos    Diviner    Charioteer    Horses from Oinomaos' or Pelops' chariot    Kneeling youth (Myrtilos?)    Sterope or Hippodameia    Pelops    Zeus    Oinomaos    Hippodameia or Sterope    Kneeling girl    Horses from Oinomaos or Pelops' chariot    Old diviner (Iamos?)    Crouching youth (possibly Arkas)    Kladeos or Alpeios*







*Lapith woman   Old Lapith woman   Lapith   Centaur   Lapith woman   Centaur and Lapith   Theseus   Centaur   Lapith woman   Apollo   Deidameia and Centaur Eurytion   Peirithoos   Lapith and Centaur   Lapith woman and Centaur   Lapith   Old Lapith woman   Lapith woman*

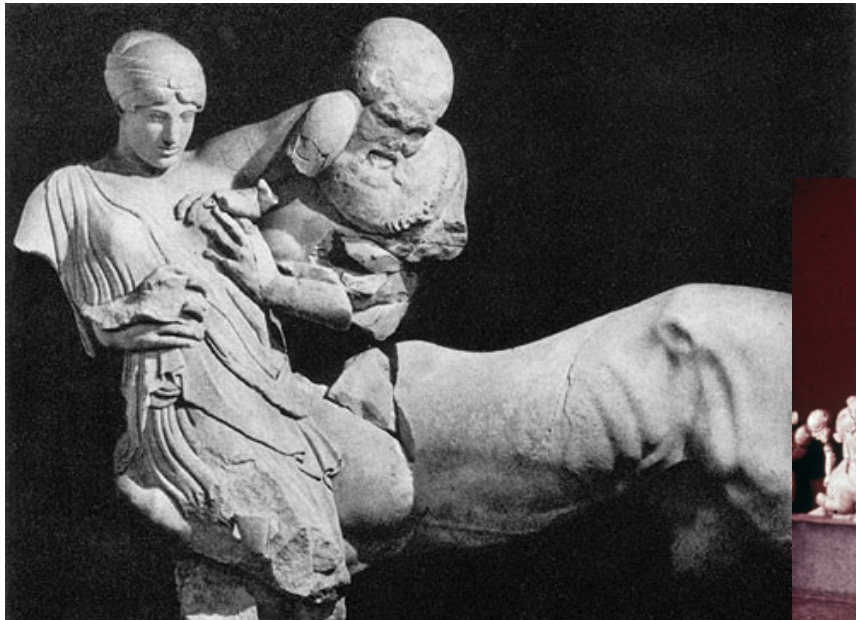

Athena

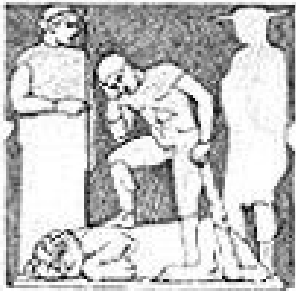

Athena

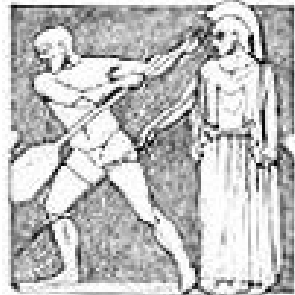
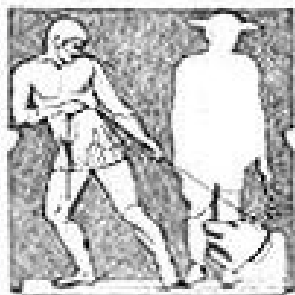
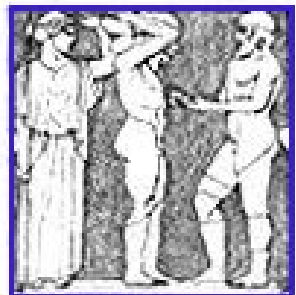
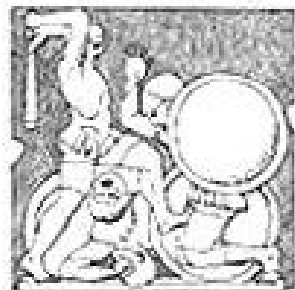
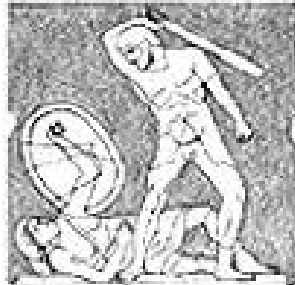
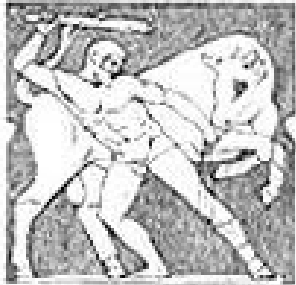
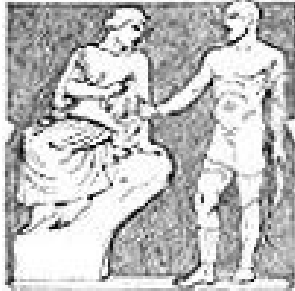

Athena

Athena





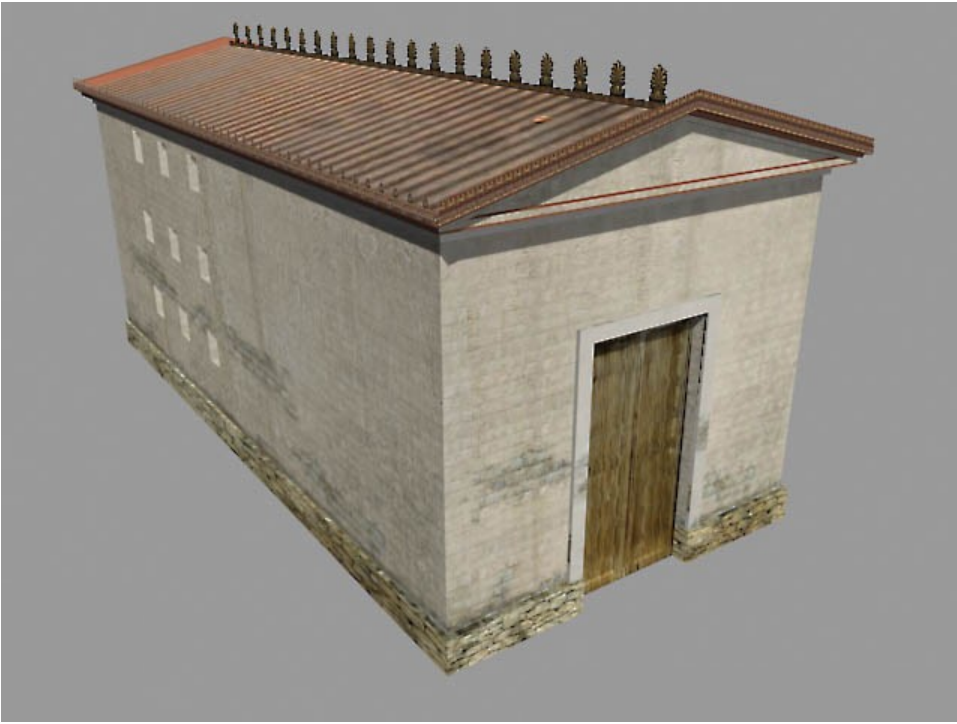





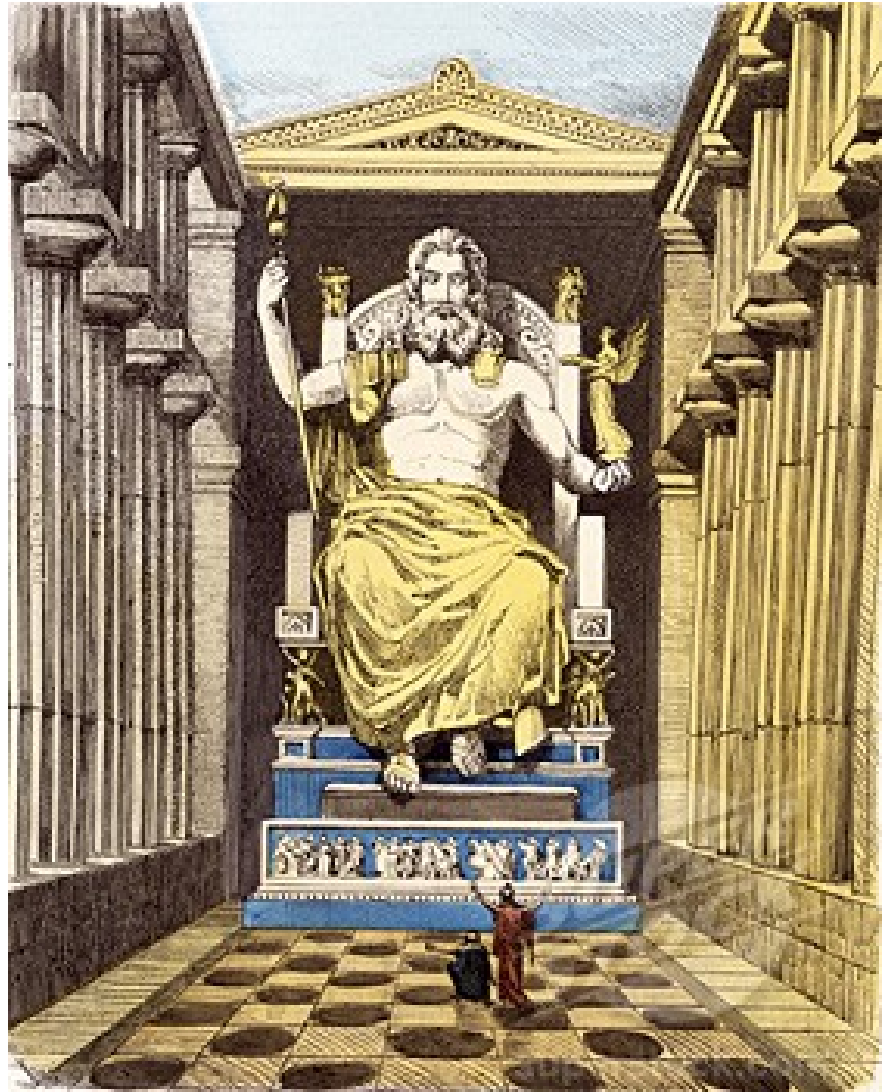



Olympia, Metroon

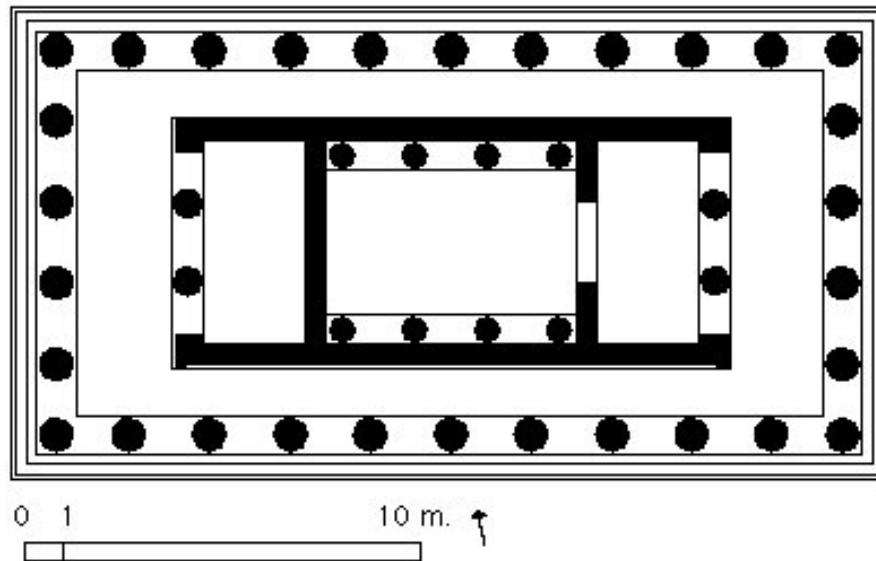





ח

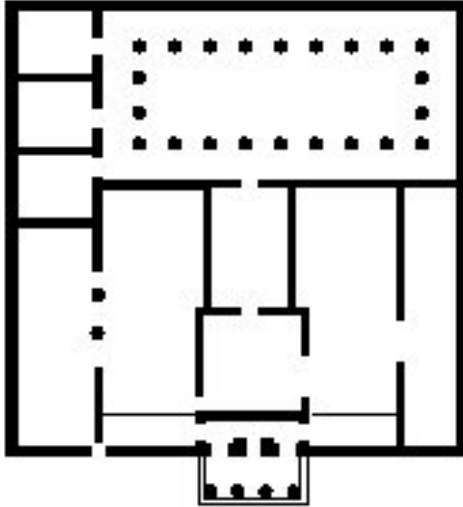

0 10 m.





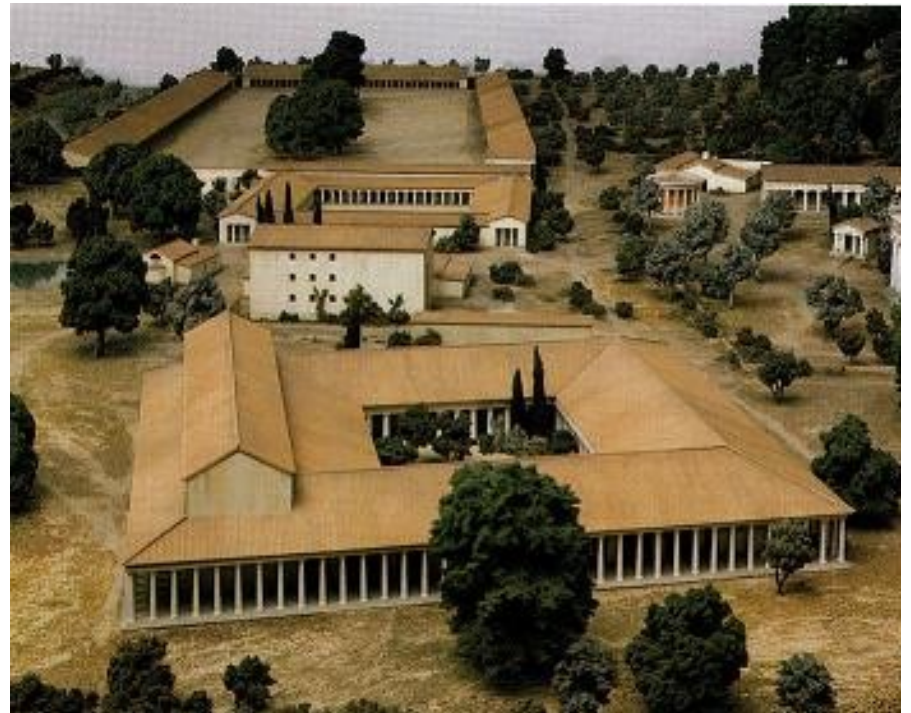
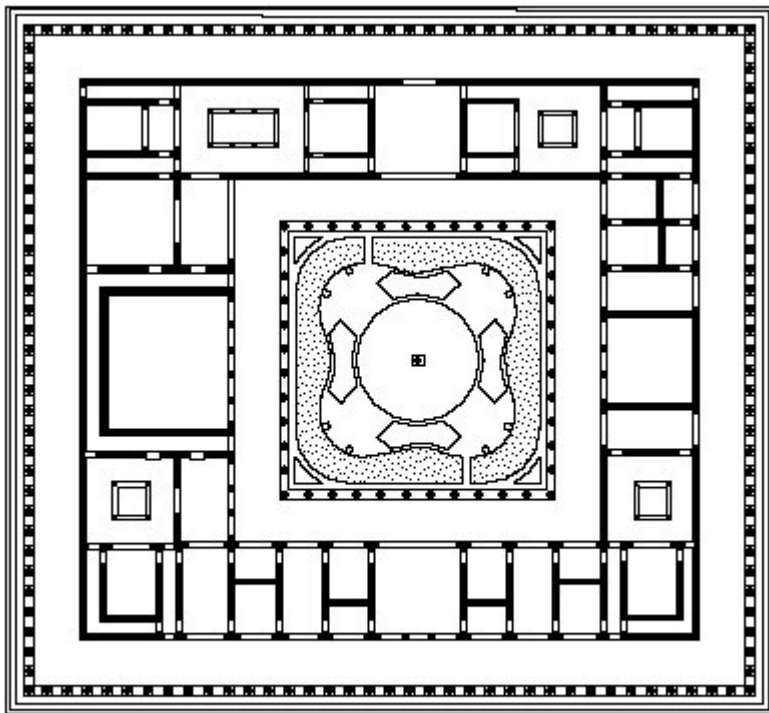

# Olympia, Echohall (Painted Stoa)

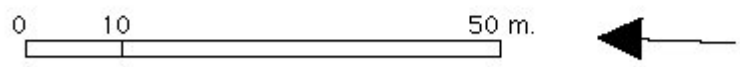
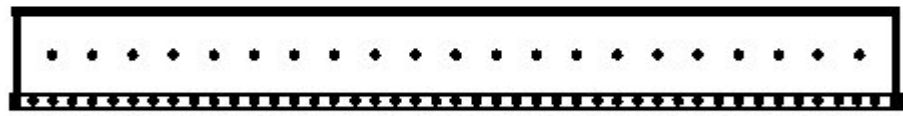



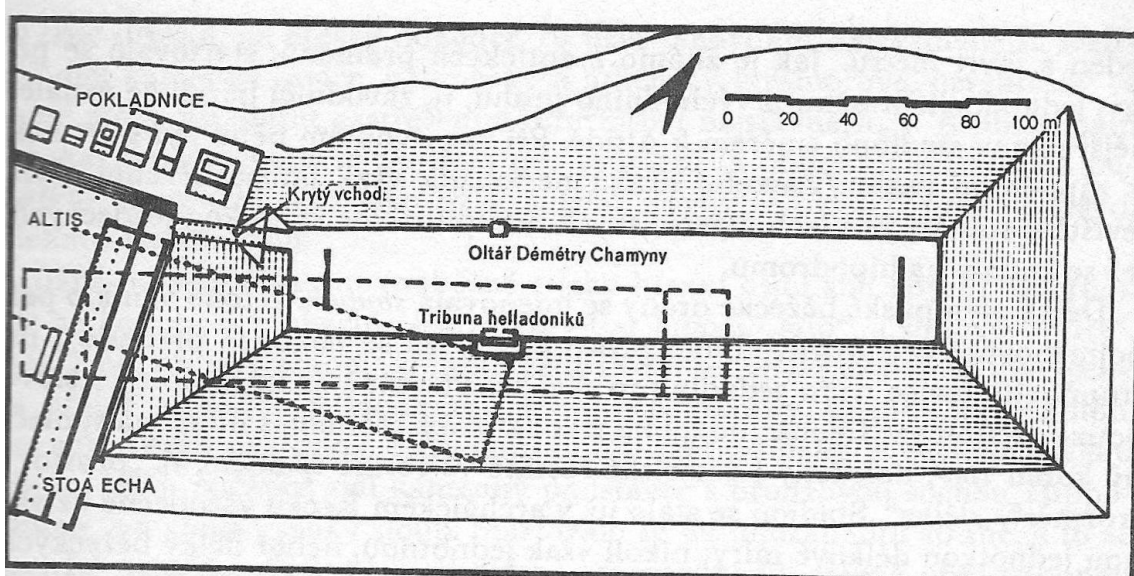

© shunya.net





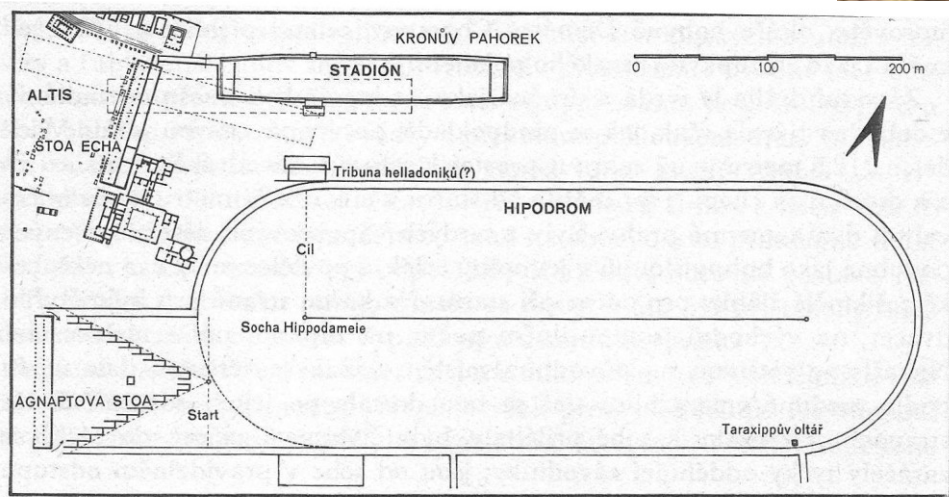
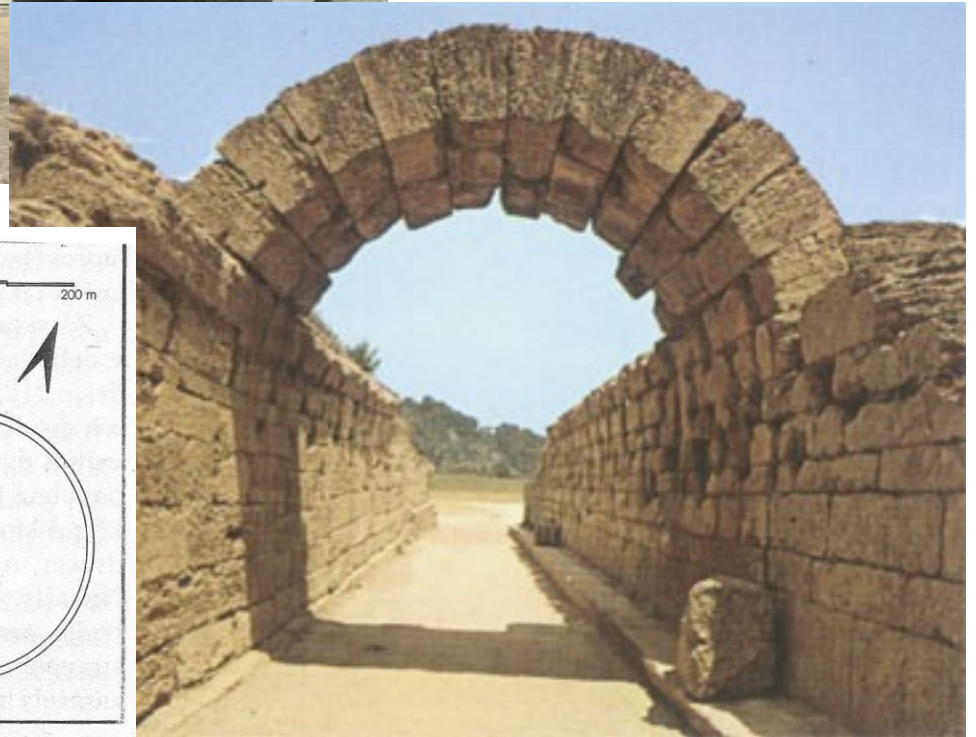



Olympia, Philippeion

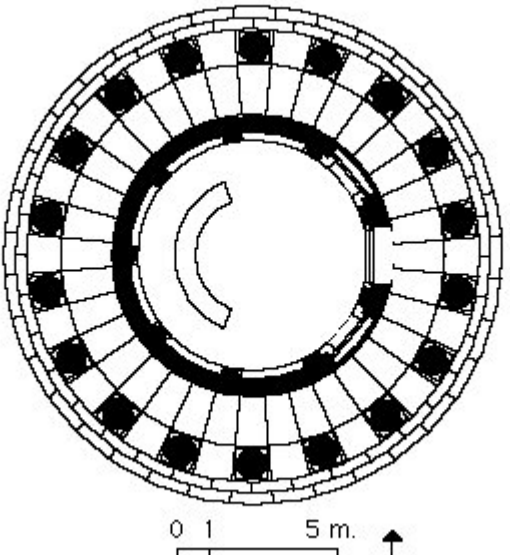

Olympia, Palaestra

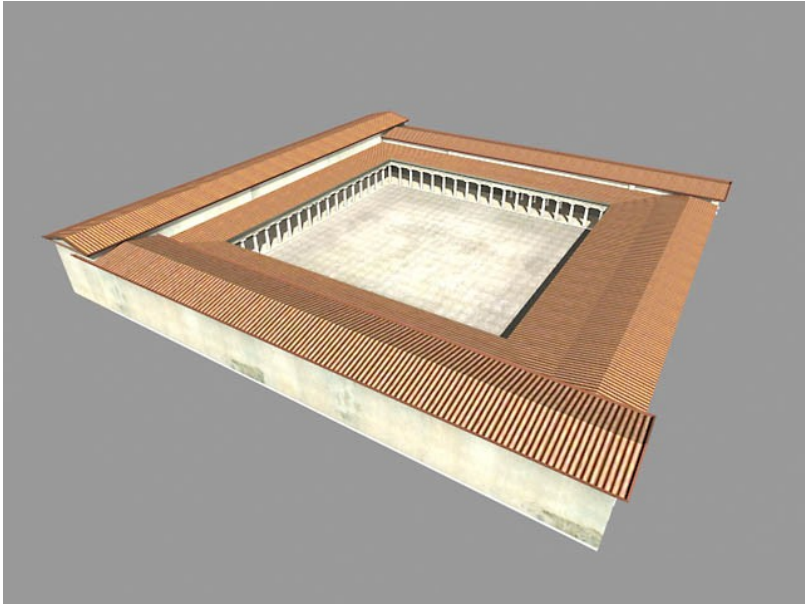
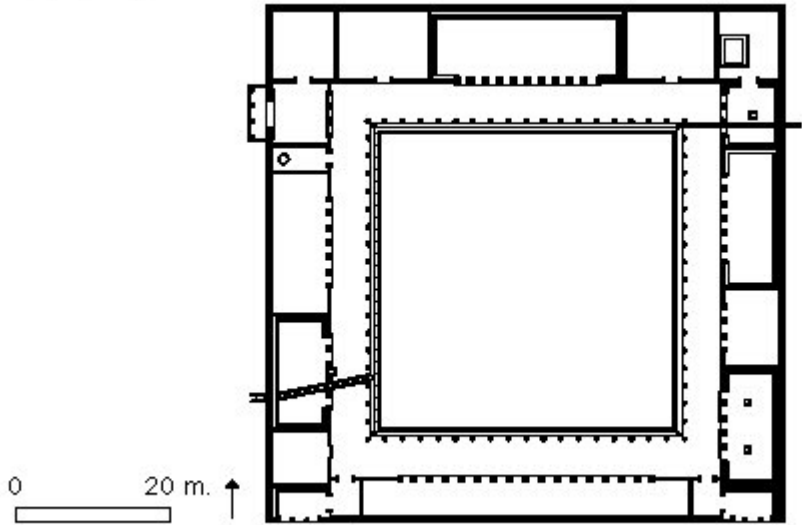



# Olympia, Gymnasium

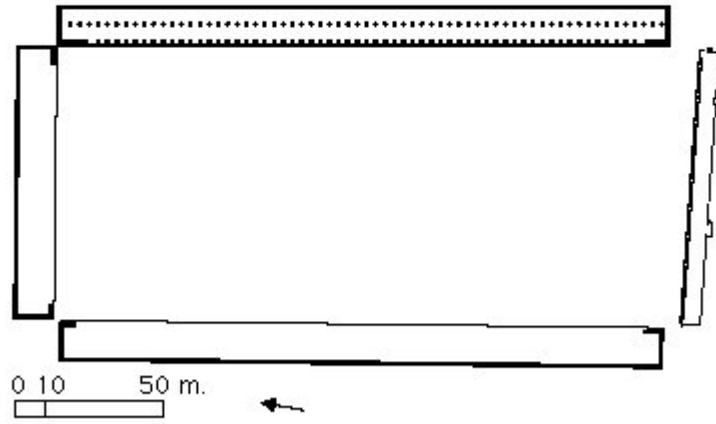

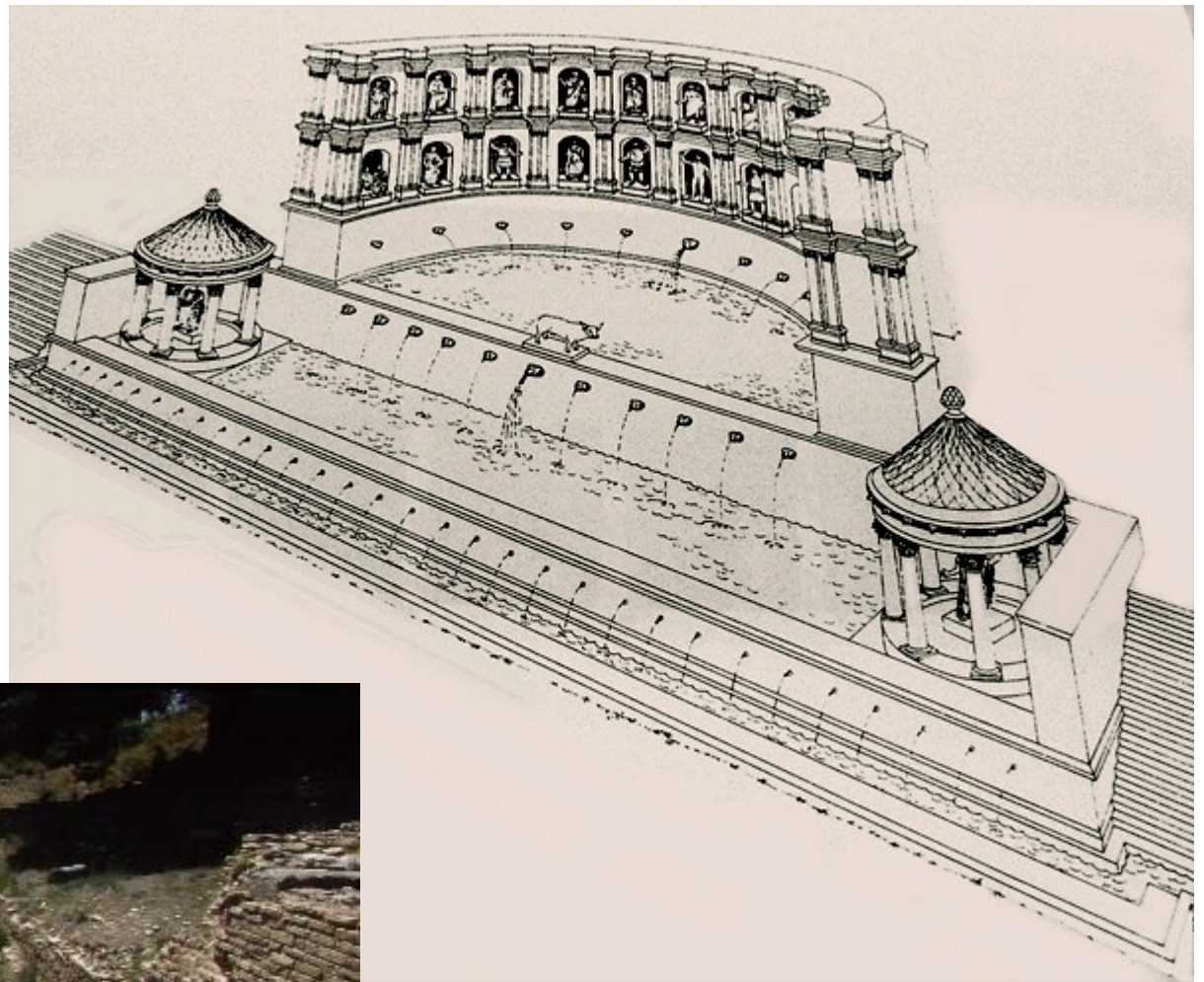





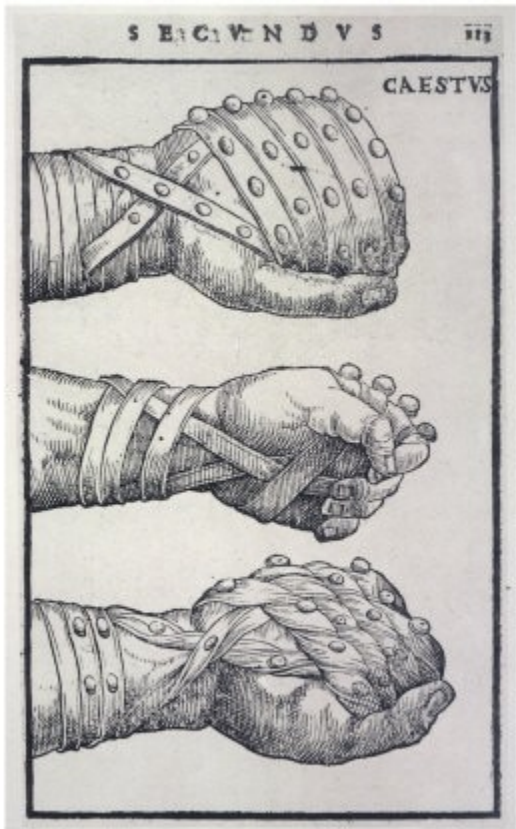
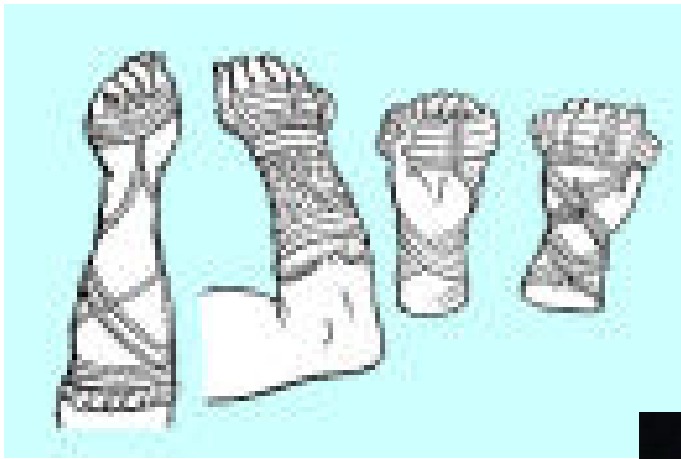



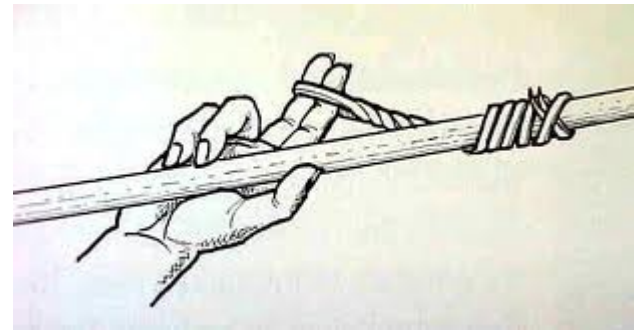



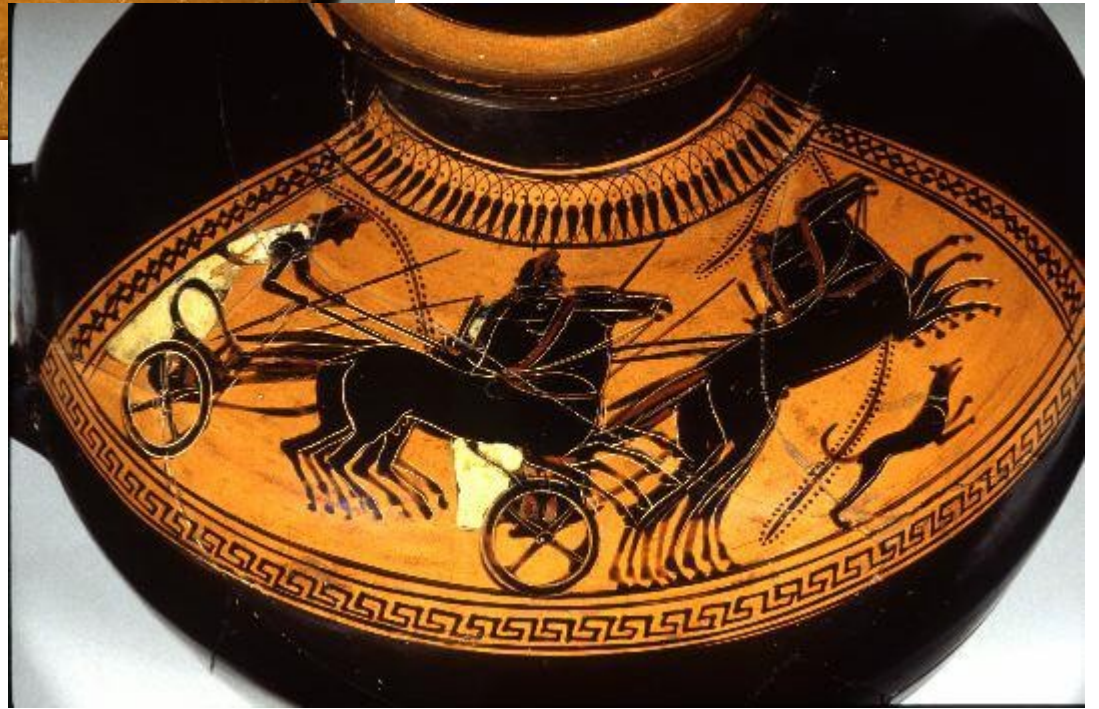



# LITERATURA

- ZAMAROVSKÝ, Vojtěch. *Vzkříšení Olympie*. Praha: Olympia, 1980.
- BAHNÍK, Václav. *Slovník antické kultury*. Praha: Svoboda, 1974.
- SVOBODA, Ludvík. *Encyklopedie antiky*. Praha: Academia, 1973.
- NEW PAULY ONLINE, Litterae ante portas