

# Dějiny Řecka I. seminář

## 4. TÉMA OLYMPIE A OLYMPIJSKÉ HRY



### Greece and the Aegean during the Dark Ages (12th – 9th cents. BC); the most important sites

● Important settlement	Chronology:	Finding - places of imported goods:
○ Settlement (with / without architectural finds)	▬ Late Helladic (12th / early 11th cents.)	⊥ Orient
⌘ Necropolis / tomb	▬ Sub - Mycenaean / Sub - Minoan (early - mid 11th cent.)	⊘ Cyprus
⌘ Sanctuary	▬ Proto - geometric (mid 11th cent. - c. 900 BC)	⊘ Italy, Europe
⌘ Centre of pottery production	▬ Geometric (Early, Middle) (9th - early 8th cents.)	Mykenai Ancient name
? ⌘ Identification uncertain	▬ Dating certain / uncertain	Çömlekçi Modern name
		(Rhodos) Island



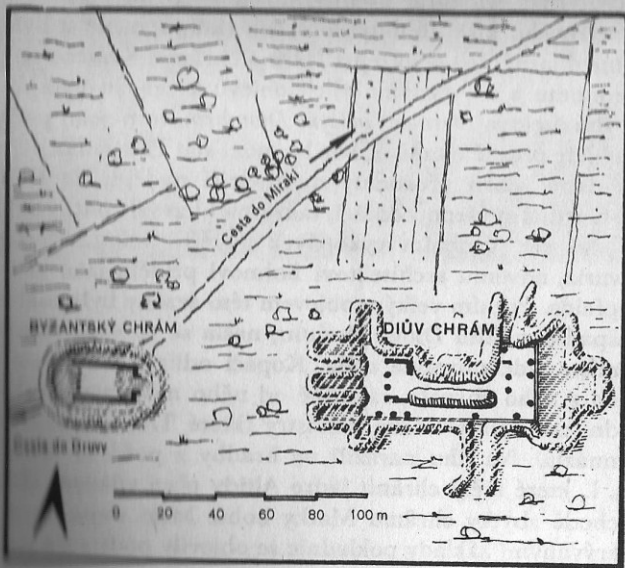

*Vykopávky v Olympii. Vlevo stav po francouzských výkopech roku 1829, vpravo po dvou sezónách německých výkopů roku 1887. Poloha stadiónu a jiných sportovních staveb nebyla tehdy ještě známa*

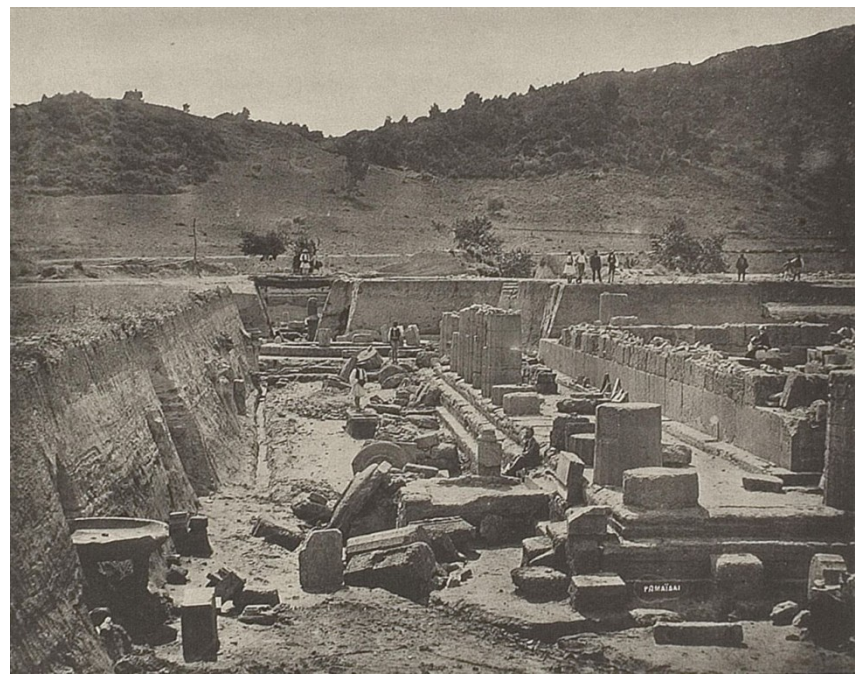
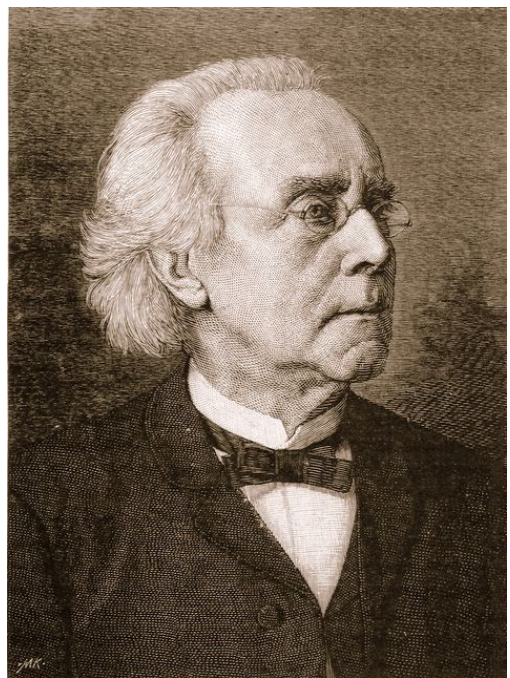
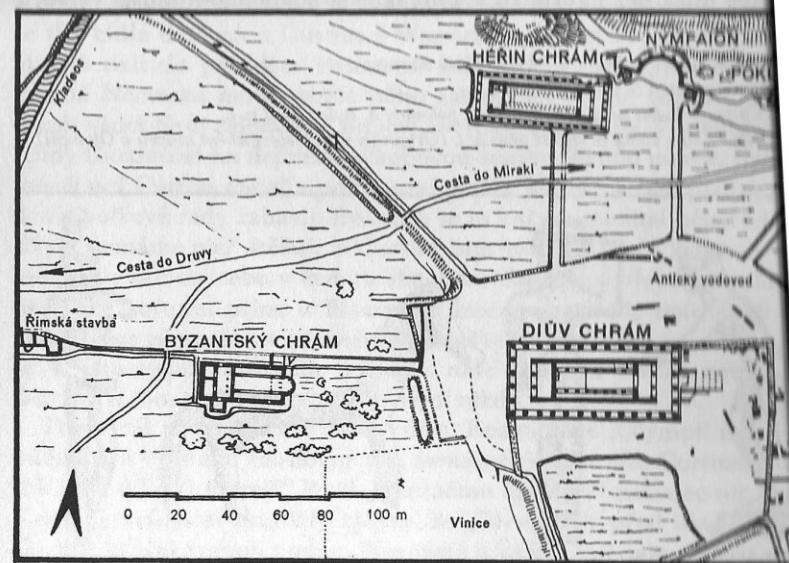



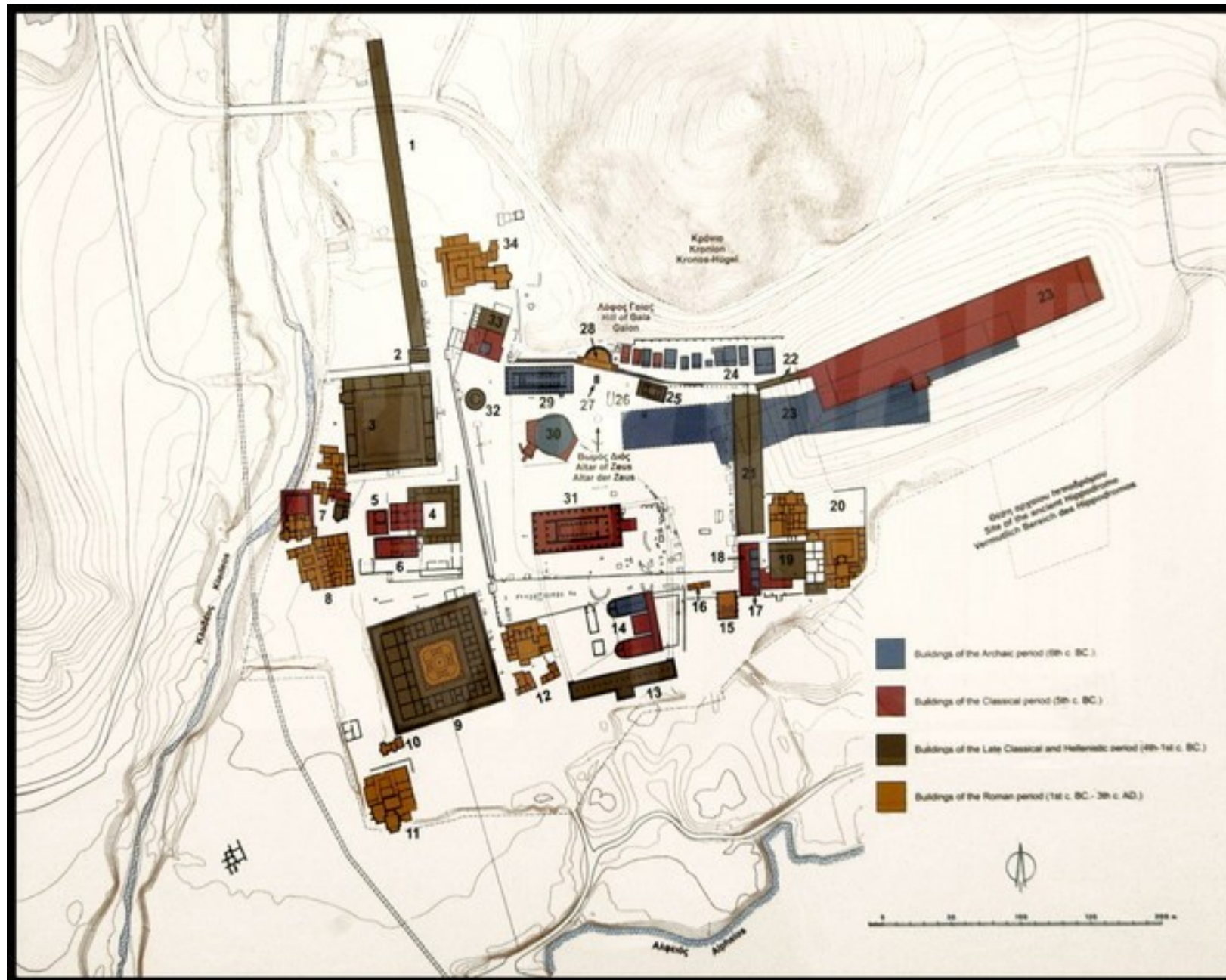

- 1. Gymnasium
- 2. Propylon
- 3. Palaestra
- 4. Theokleion
- 5. Heron
- 6. Pheidias' workshop
- 7. Kladeos baths
- 8. Roman Guest Accomodation
- 9. Leonidion
- 10. Ἰδρυτὶς Ἀσπιδοβόλου
- 11. SW Baths-Athlet's Club
- 12. Southern Baths
- 13. Southern Colonnade
- 14. Bouleuterion
- 15. Odeion
- 16. Arch of Nero
- 17. Sanctuary of Hestia
- 18. SE building
- 19. Greek Building
- 20. Octagon
- 21. Echo Colonnade
- 22. Krypte
- 23. Stadion
- 24. Treasuries
- 25. Metroon
- 26. Prehistoric apsidal building II
- 27. Altar of Hera
- 28. Nymphaion
- 29. Herain
- 30. Pelopion
- 31. Temple of Zeus
- 32. Philoppeion
- 33. Pnythelion
- 34. Building of a Roman House





*An aerial view of Olympia, Greece*







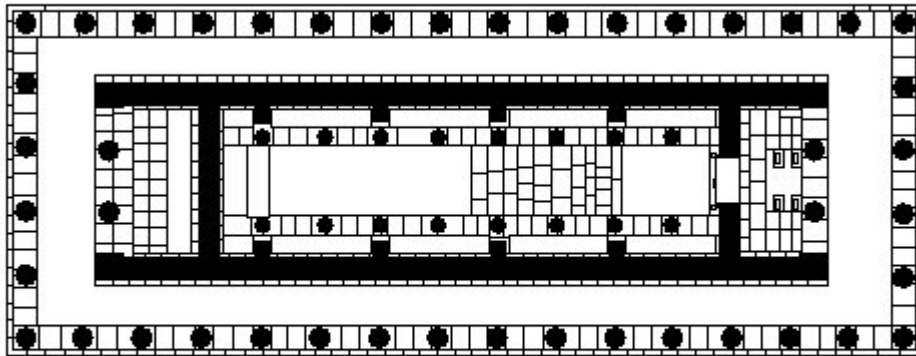

0.1 10 m. ↑

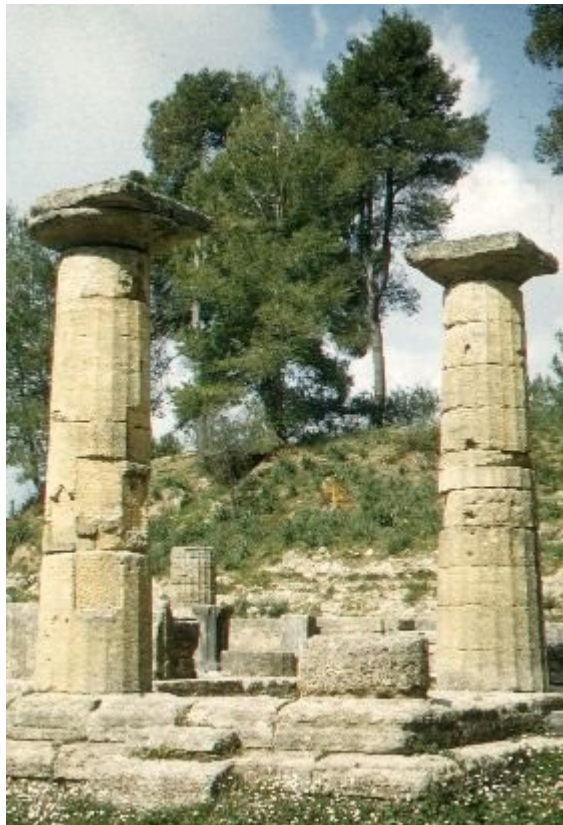









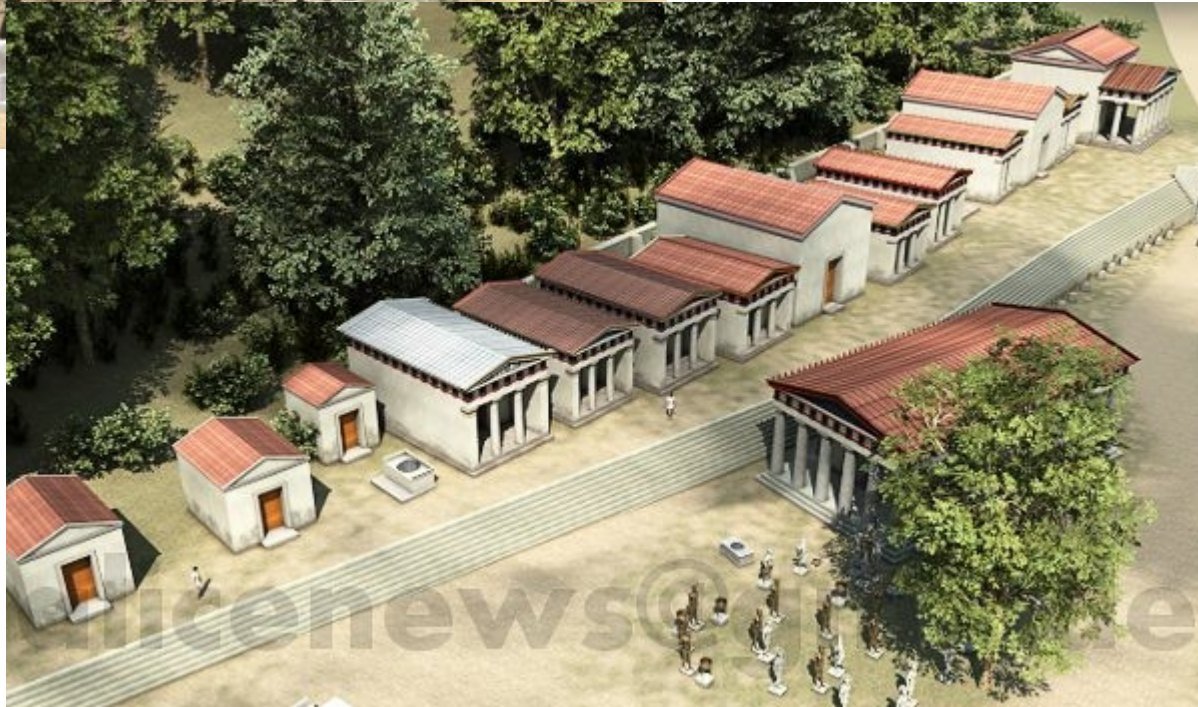
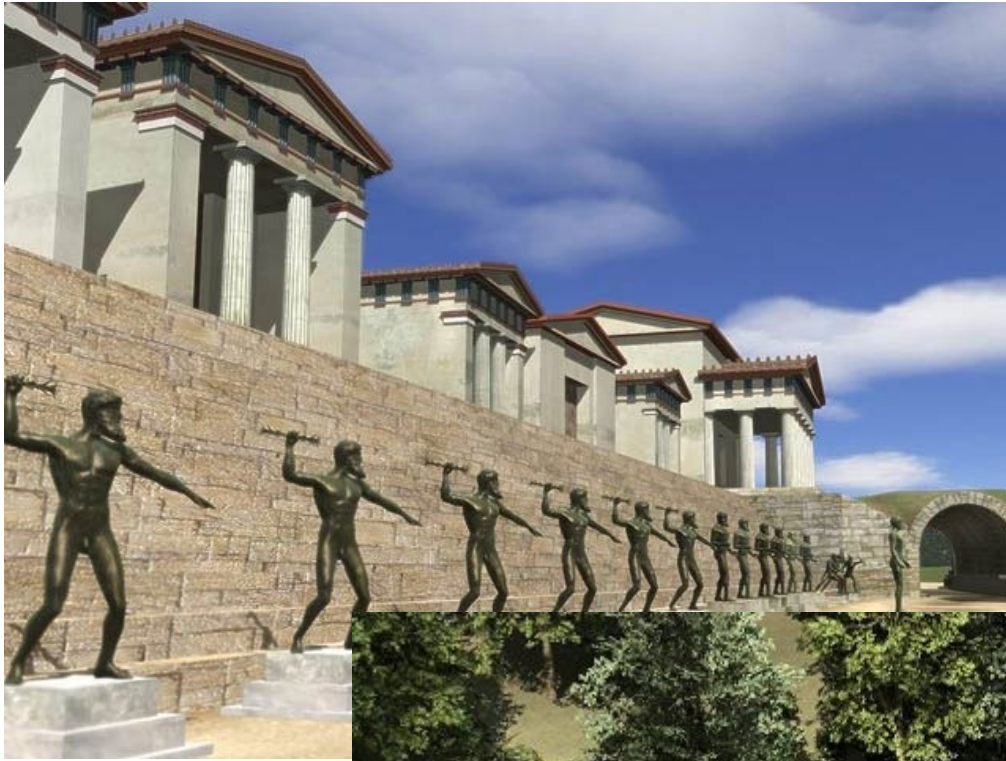



Olympia, Pelopeion

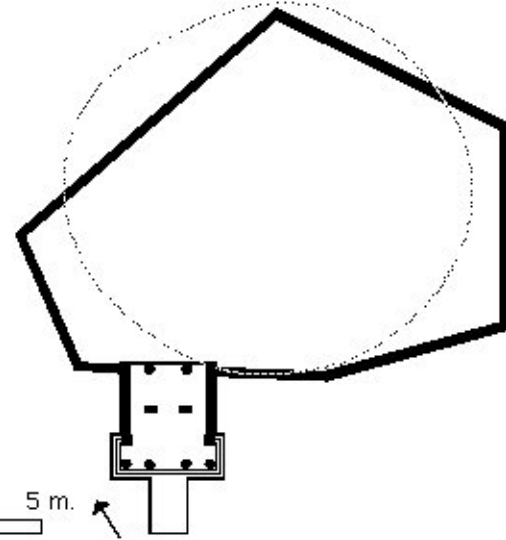
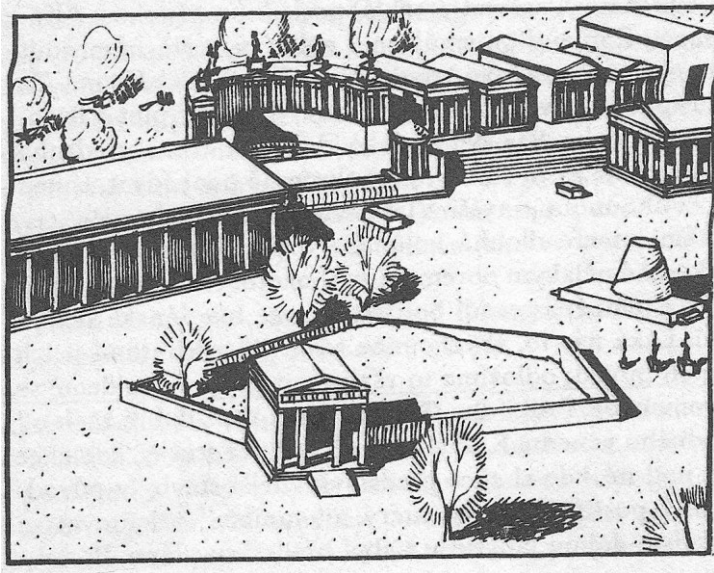





# Olympia, Bouleuterion

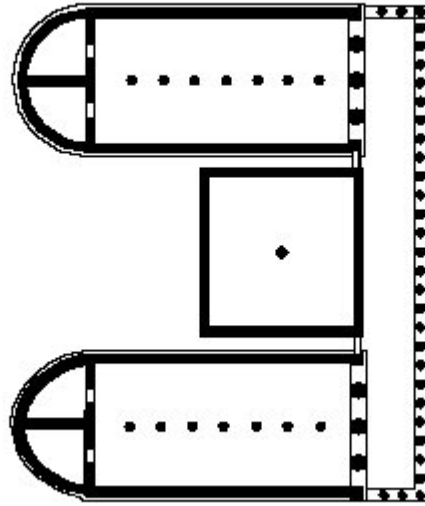

0 10 m.  



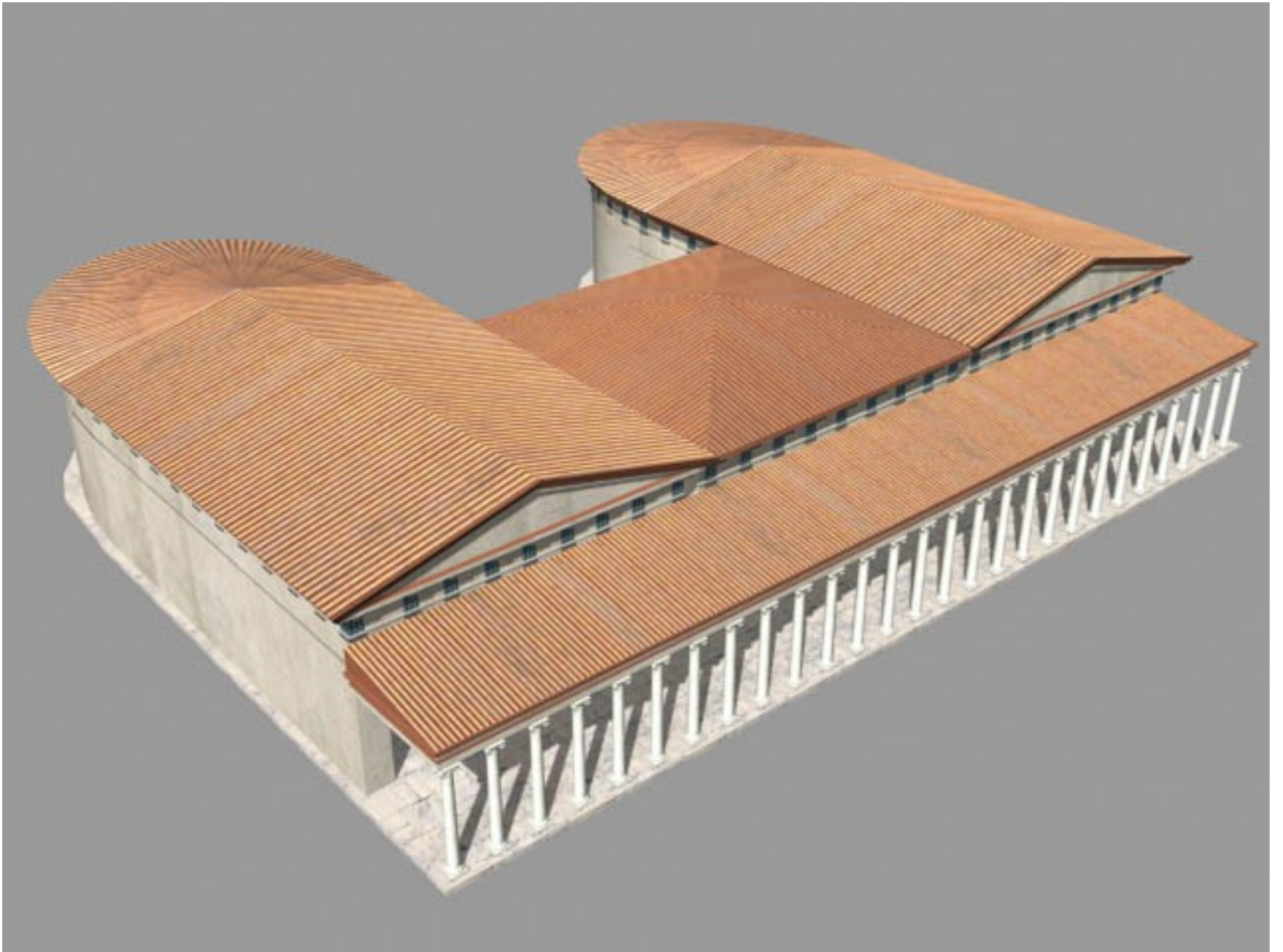



# Olympia, Temple of Zeus

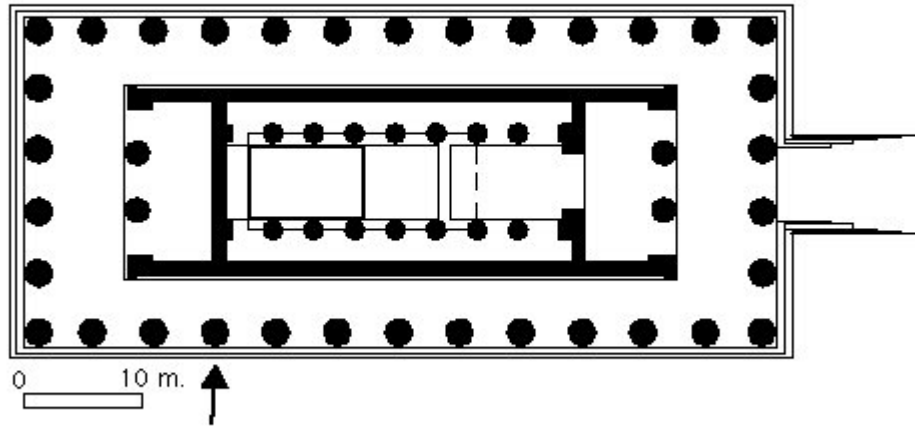







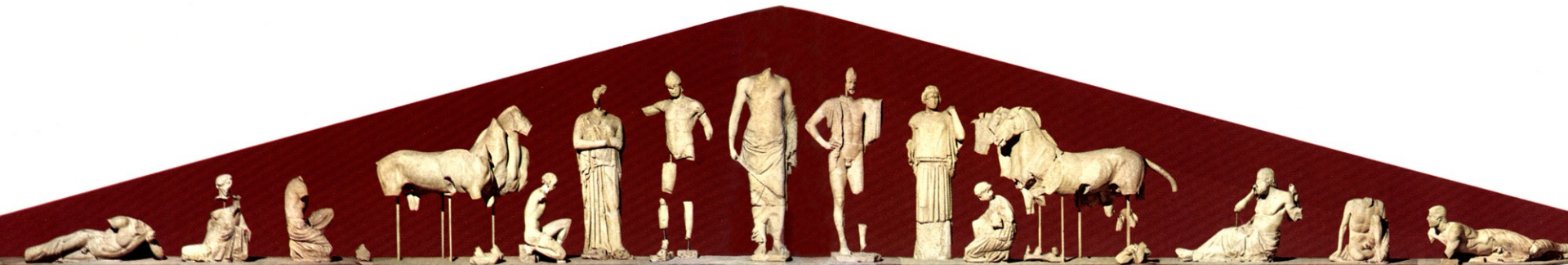

*Alpheios or Kladeos*

*Diviner*

*Charioteer*

*Horses from Oinomaos' or Pelops' chariot*

*Kneeling youth (Myrtilos?)*

*Sterope or Hippodameia*

*Pelops*

*Zeus*

*Oinomaos*

*Hippodameia or Sterope*

*Kneeling girl*

*Horses from Oinomaos' or Pelops' chariot*

*Old diviner (Iamos?)*

*Crouching youth (possibly Arkas)*

*Kladeos or Alpheios*







*Lapith woman   Old Lapith woman   Lapith   Centaur   Lapith woman   Centaur and Lapith   Theseus   Centaur   Lapith woman   Apollo   Deidameia and Centaur Eurytion   Peirithoos   Lapith and Centaur   Lapith woman and Centaur   Lapith   Old Lapith woman   Lapith woman*

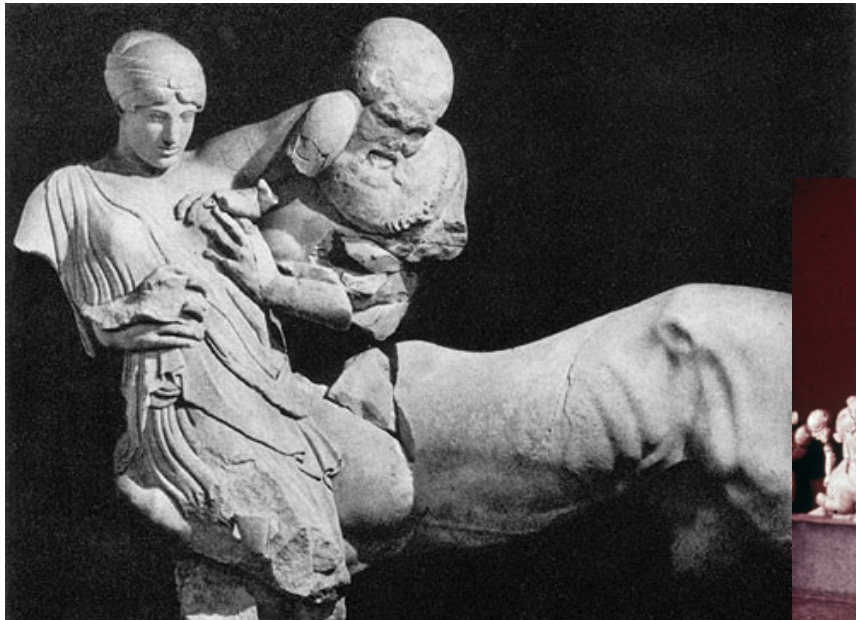

Athena

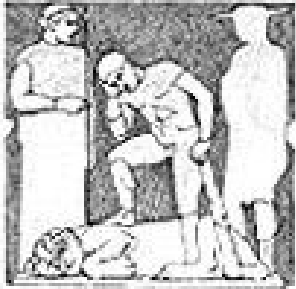

Athena

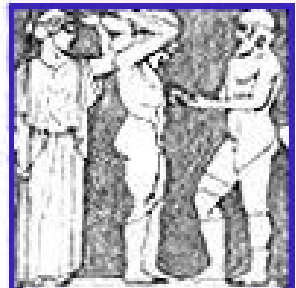
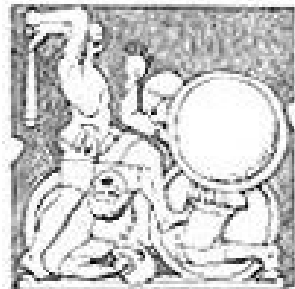
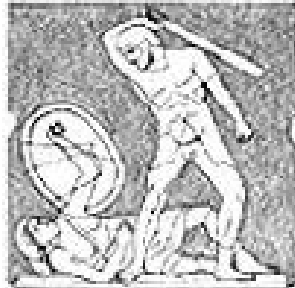
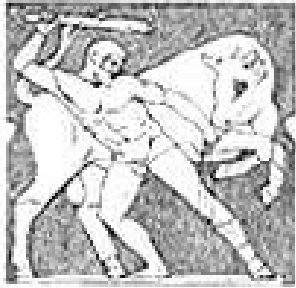
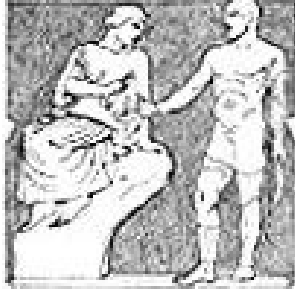

Athena

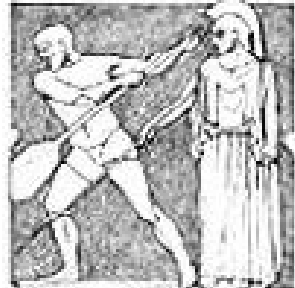
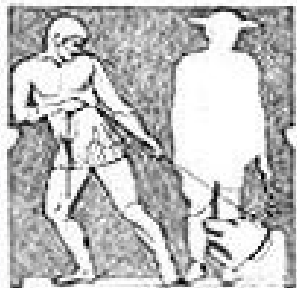

Athena





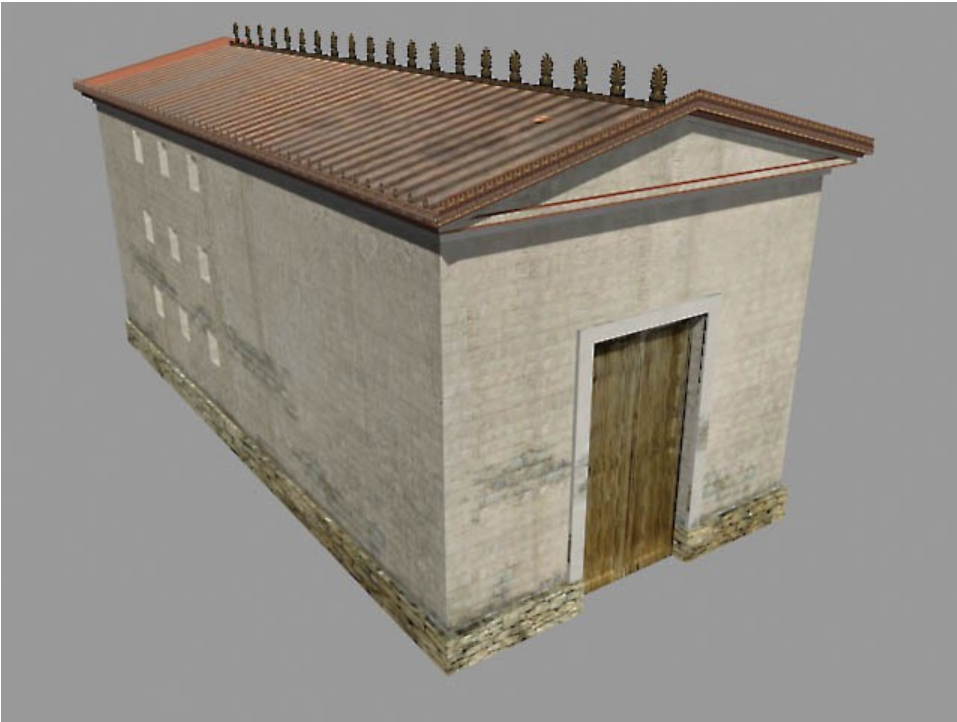





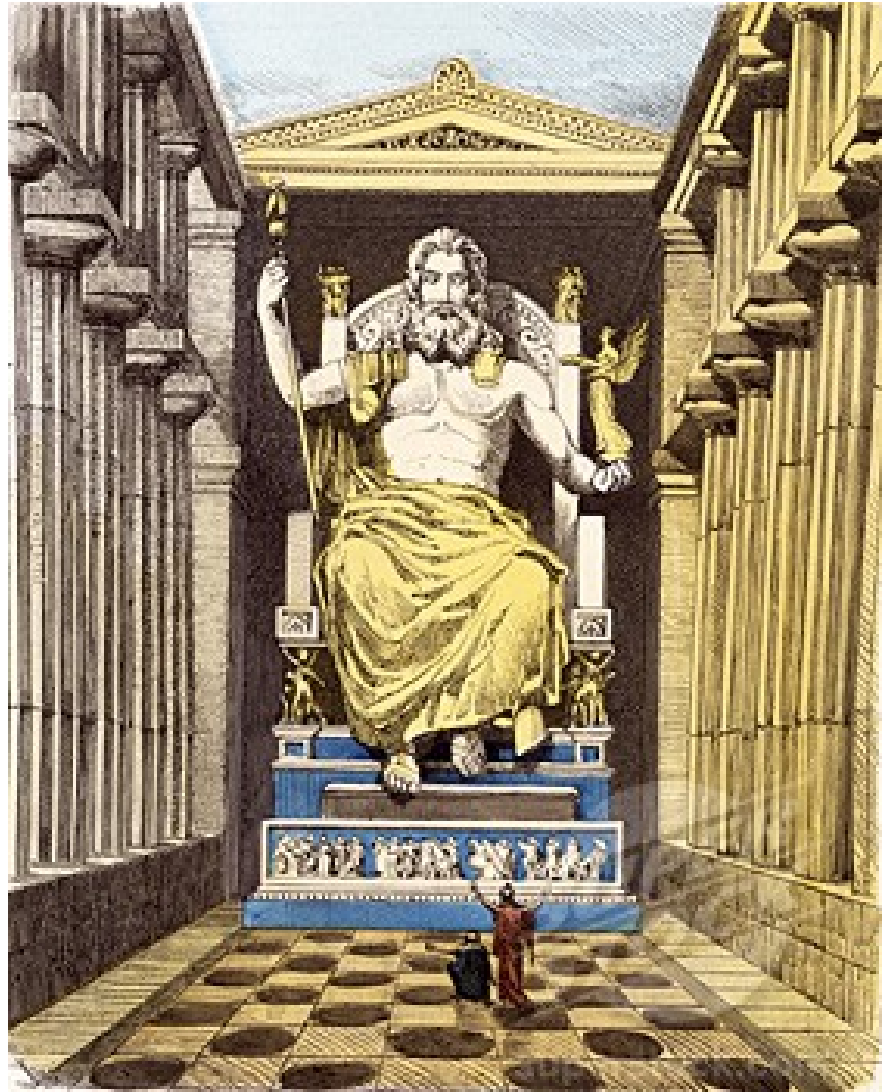



Olympia, Metroon

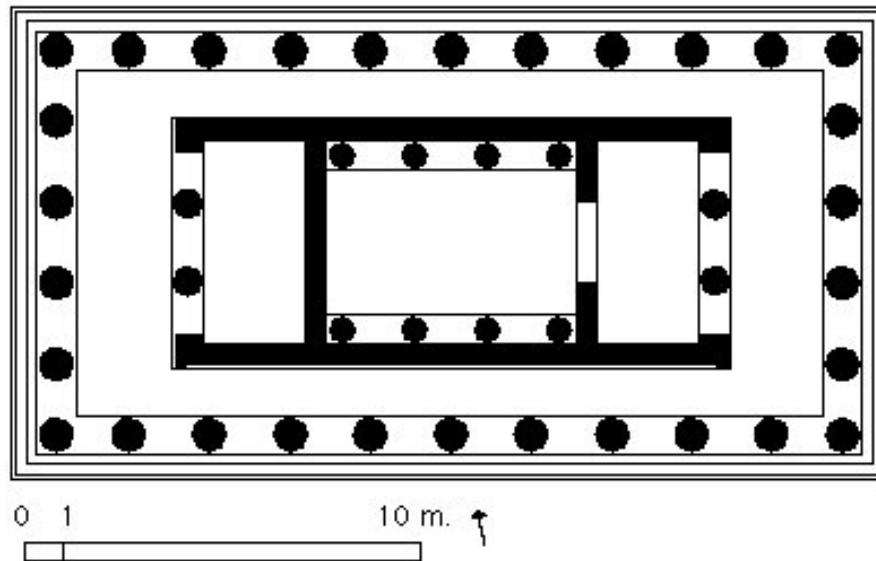





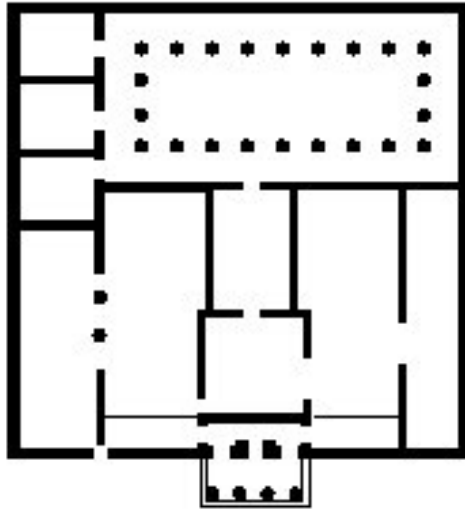

0 10 m.

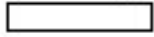



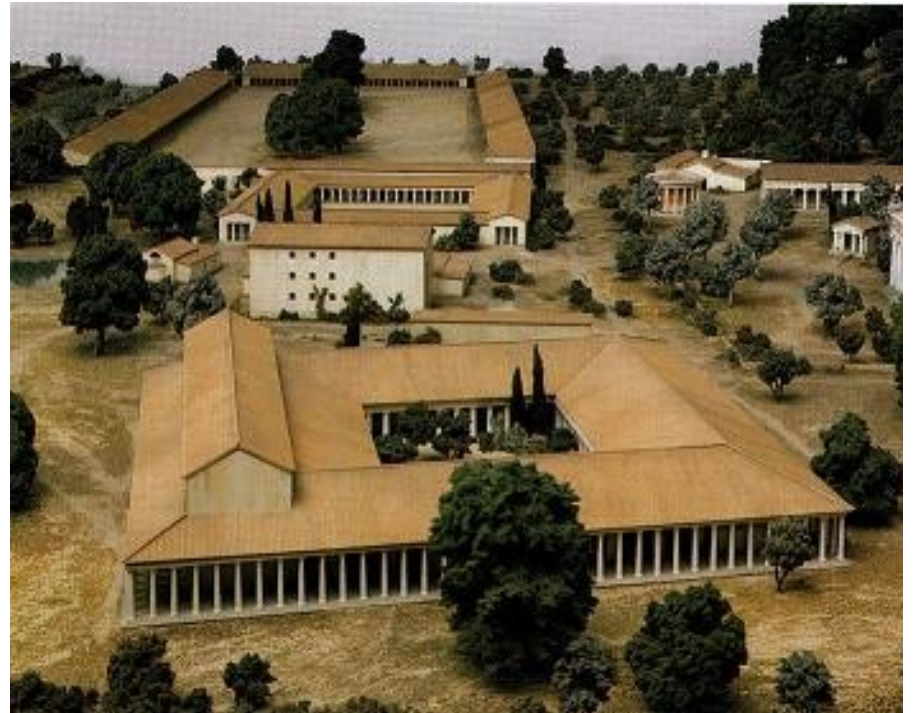
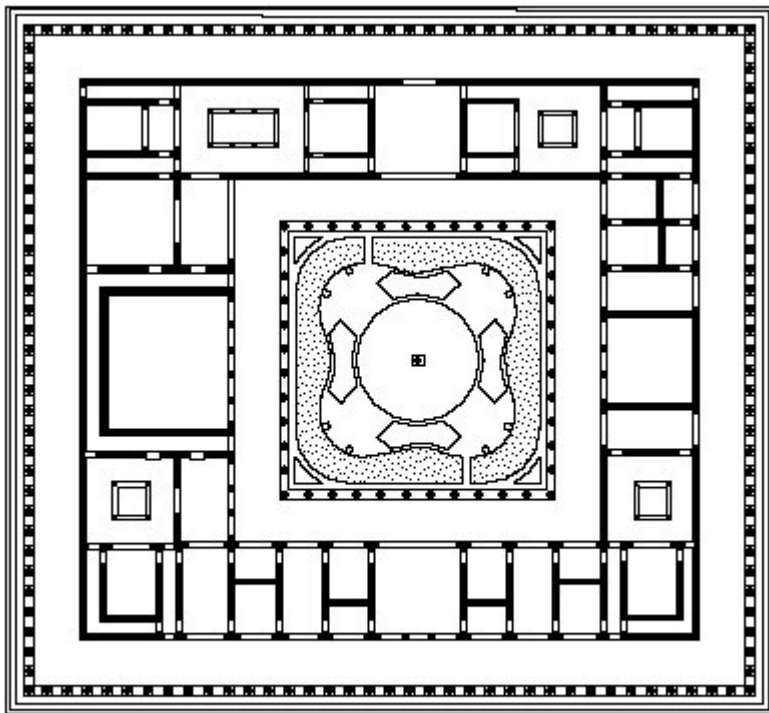

0 20 m



# Olympia, Echohall (Painted Stoa)

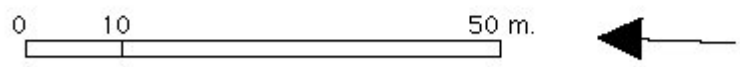
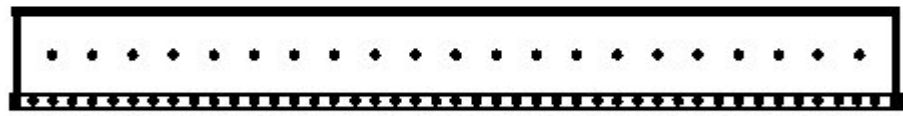



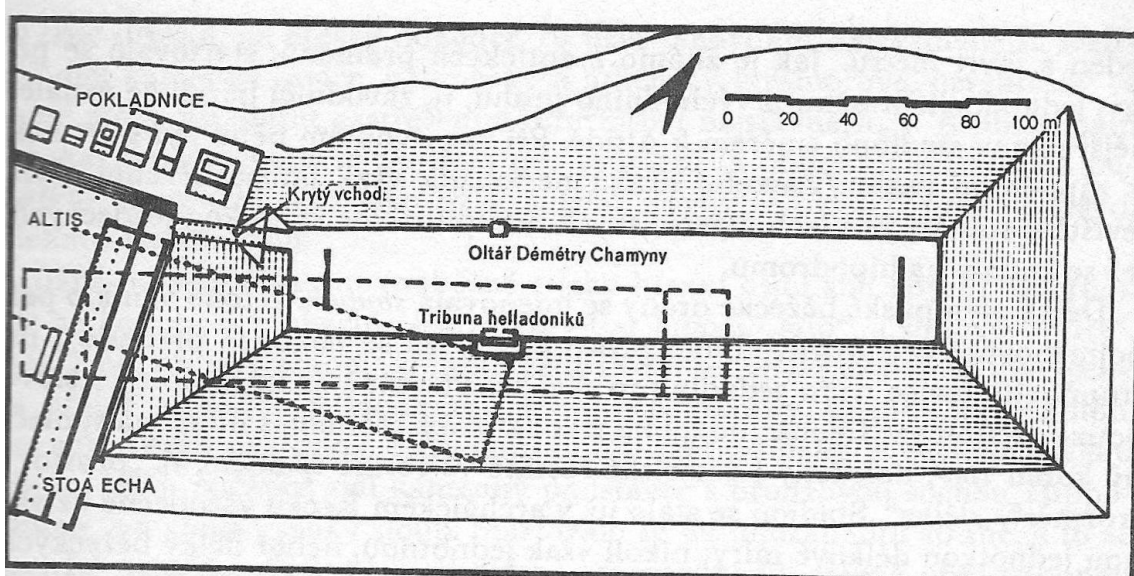

© shunya.net





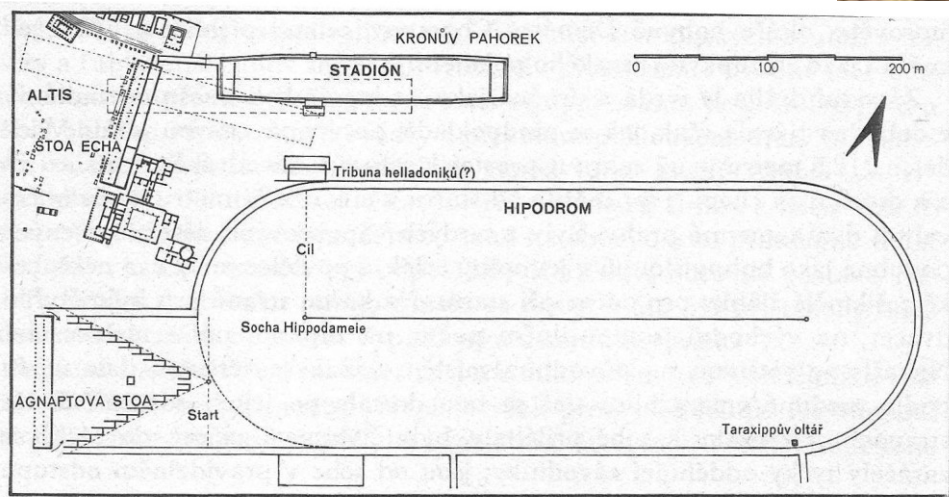
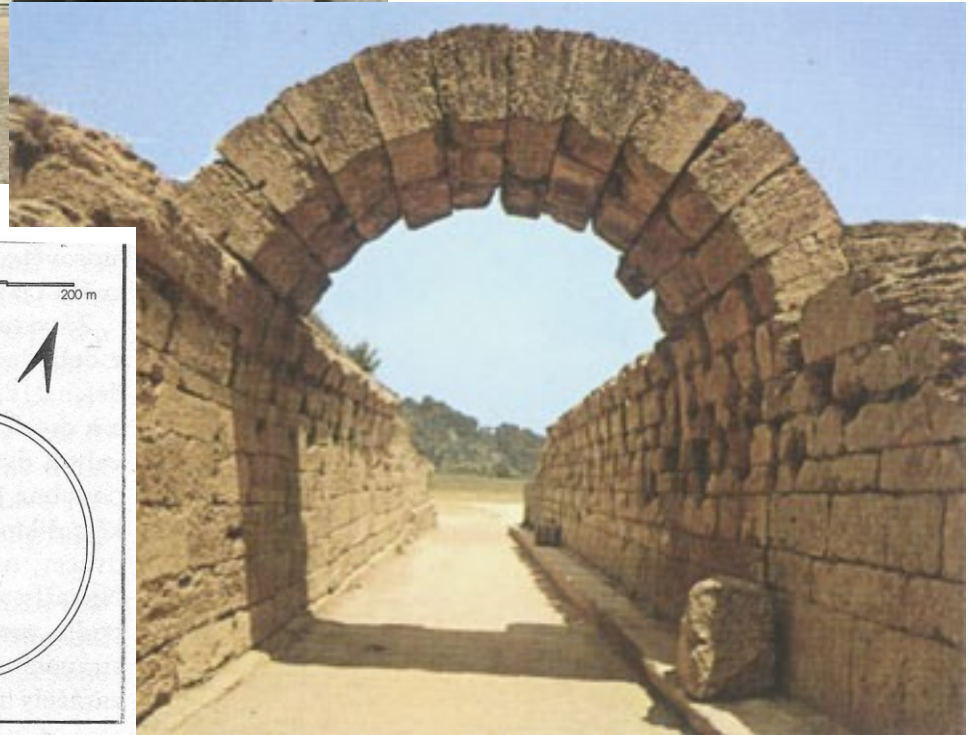



Olympia, Philippeion

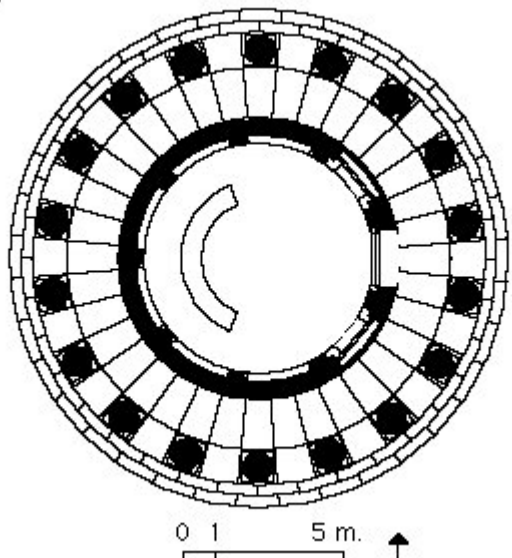

Olympia, Palaestra

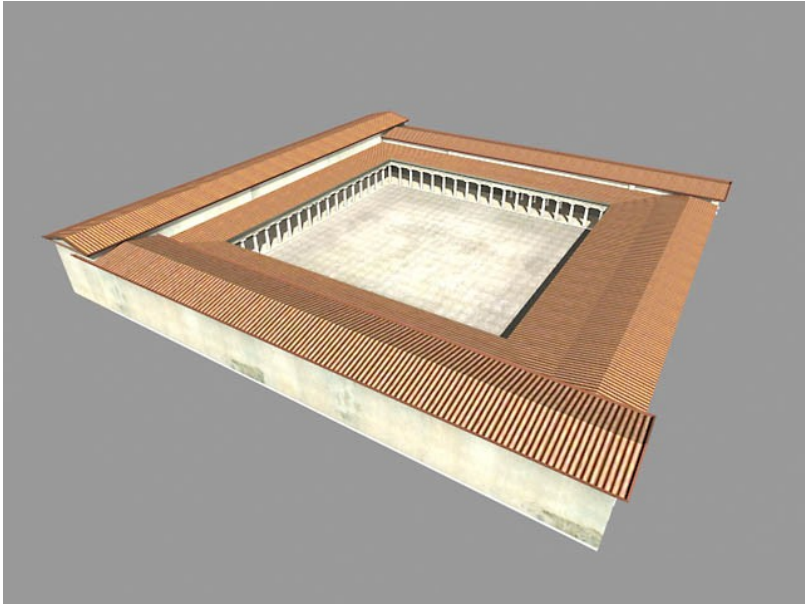
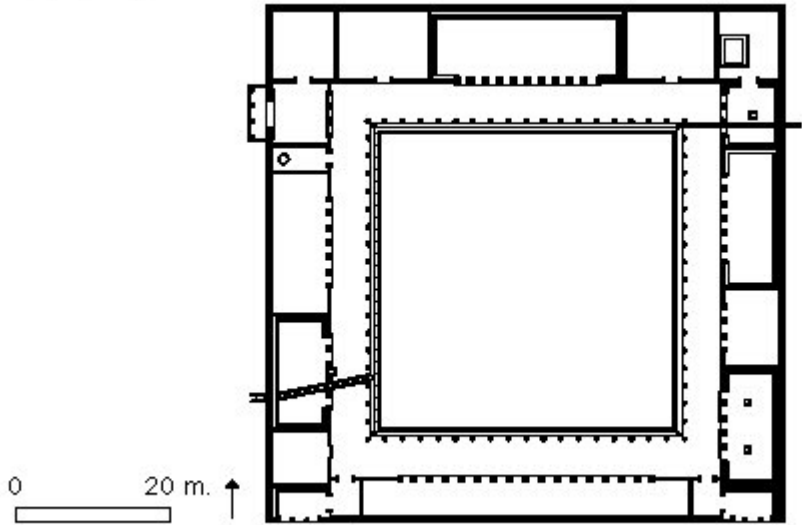



# Olympia, Gymnasium

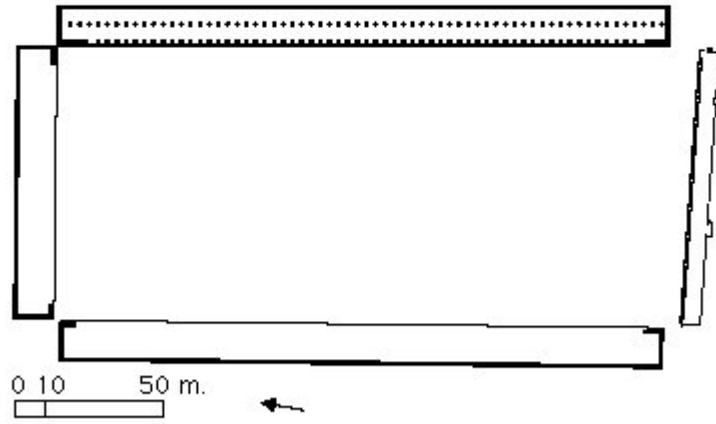

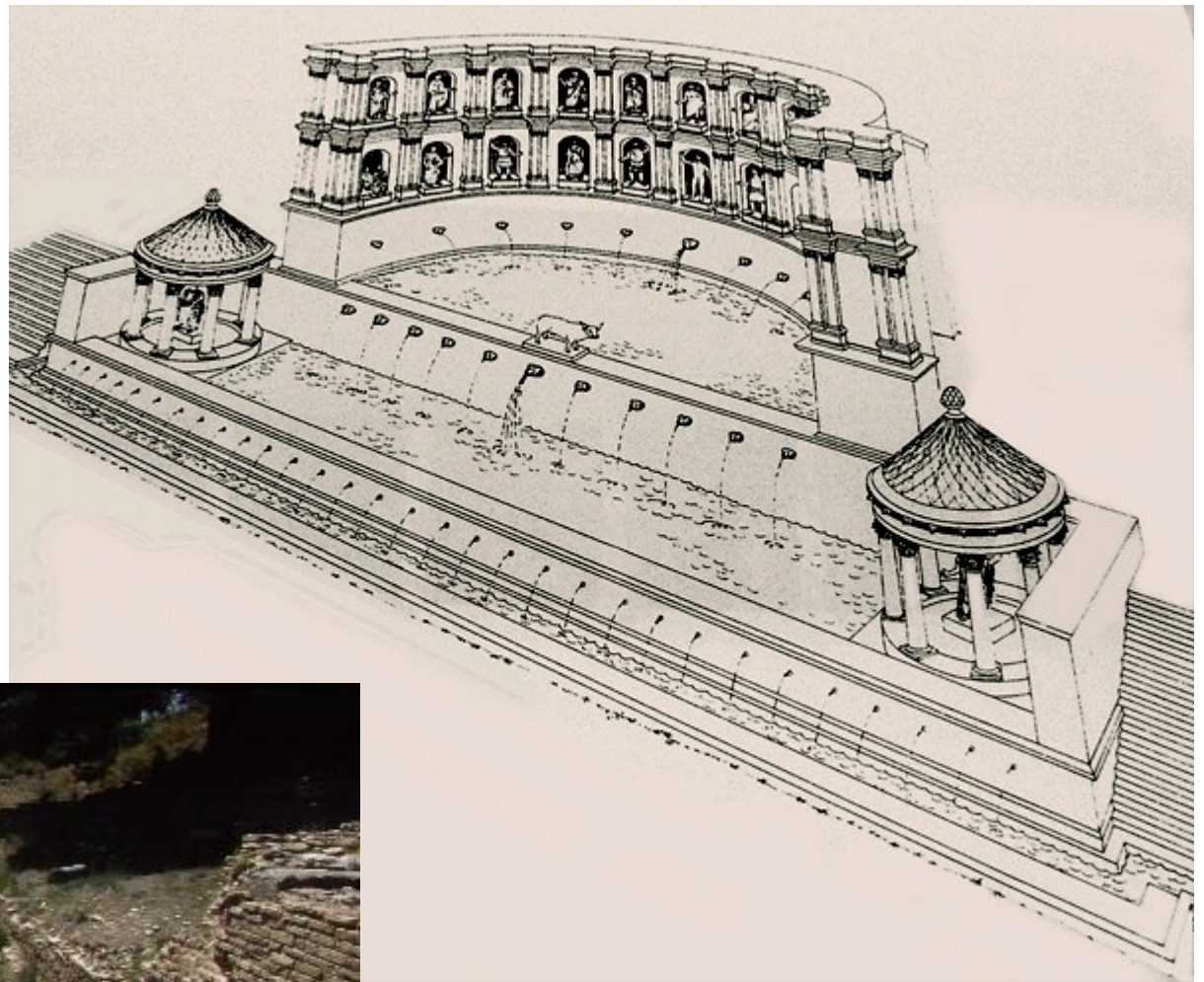





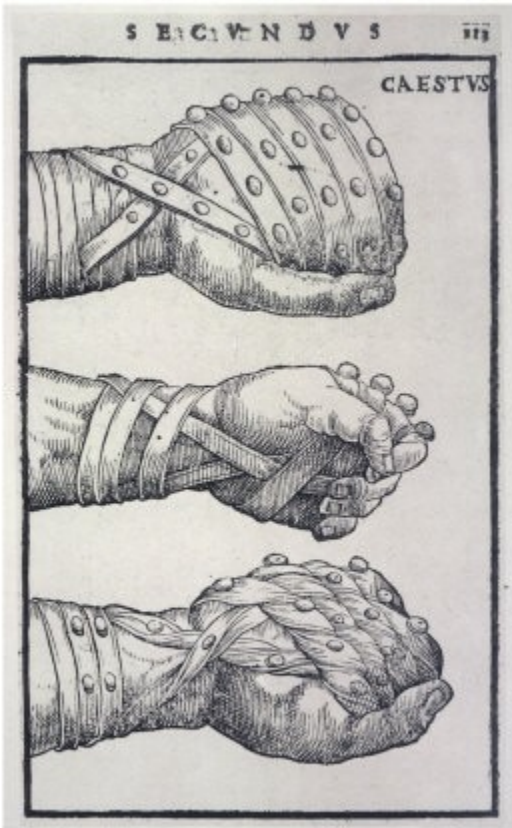
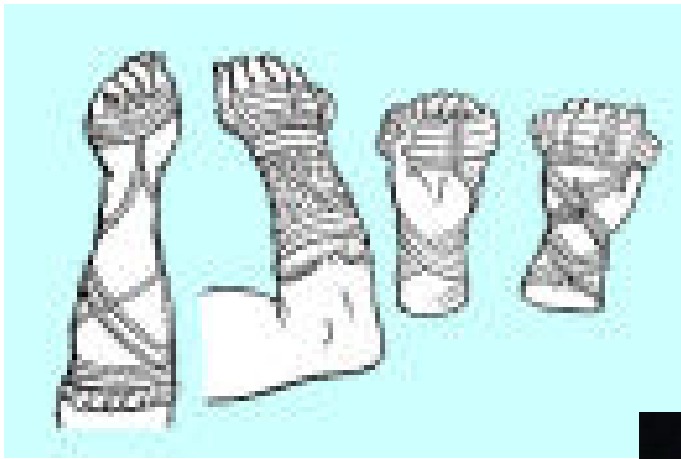



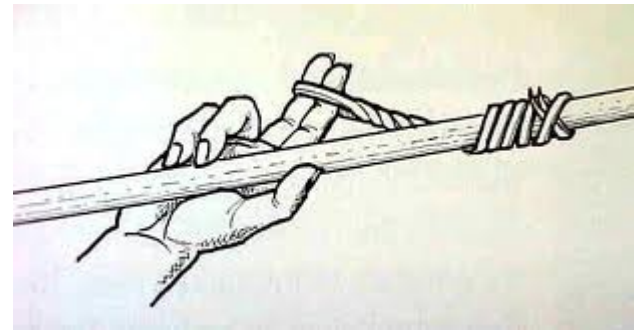



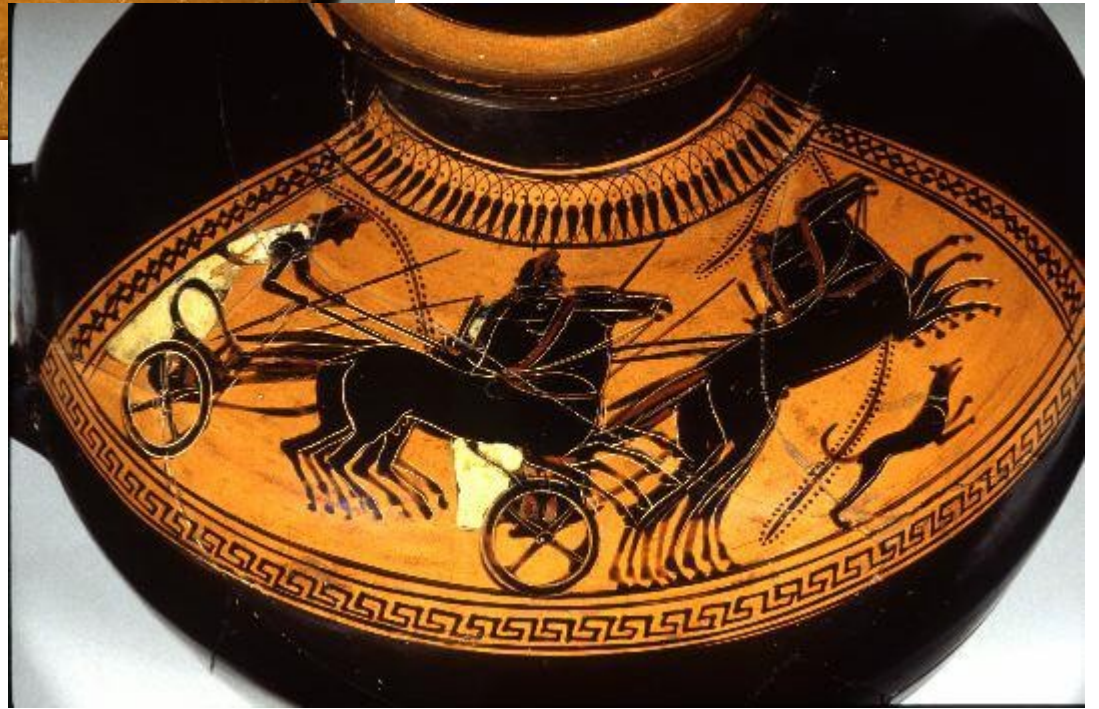



# LITERATURA

- ZAMAROVSKÝ, Vojtěch. *Vzkříšení Olympie*. Praha: Olympia, 1980.
- BAHNÍK, Václav. *Slovník antické kultury*. Praha: Svoboda, 1974.
- SVOBODA, Ludvík. *Encyklopedie antiky*. Praha: Academia, 1973.
- NEW PAULY ONLINE, *Litterae ante portas*