

# Promítací kinematografická technika

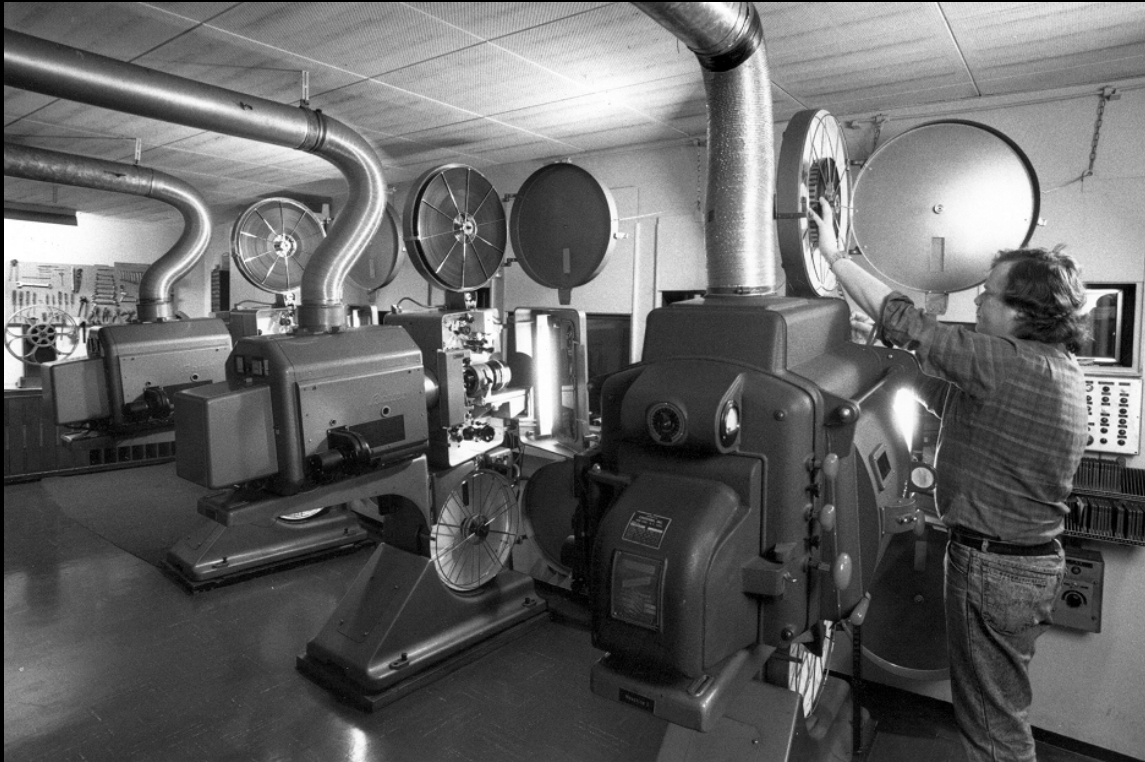

# Projekce v kině



# Periodizace

- Před rokem 1914
- Před nástupem zvuku (1914-1926)
- Ustálení po nástupu zvuku (1926-1948)
- Poválečné období (1948-1976)
- Nástup multiplexů (1976-dnes)

# Promítání před r. 1914

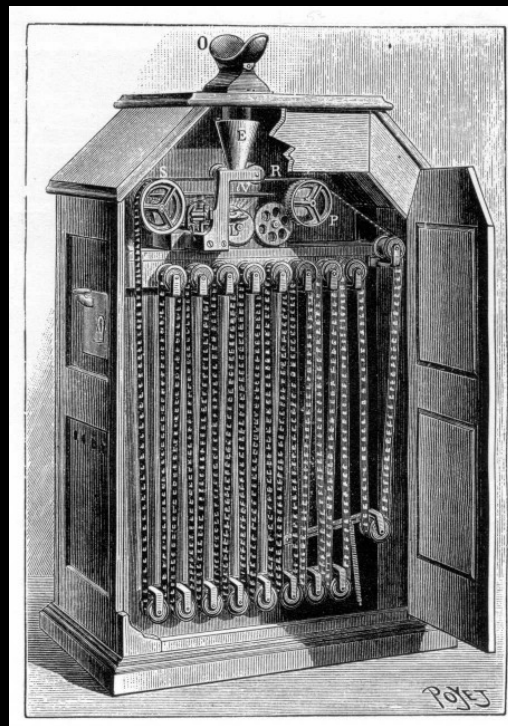

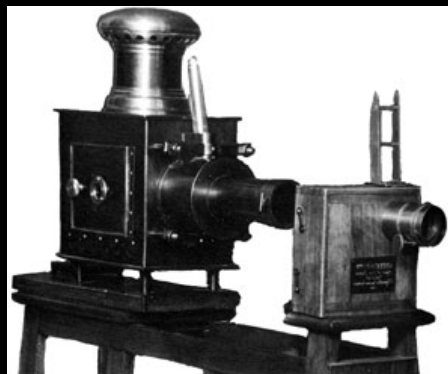

# Kinematograf

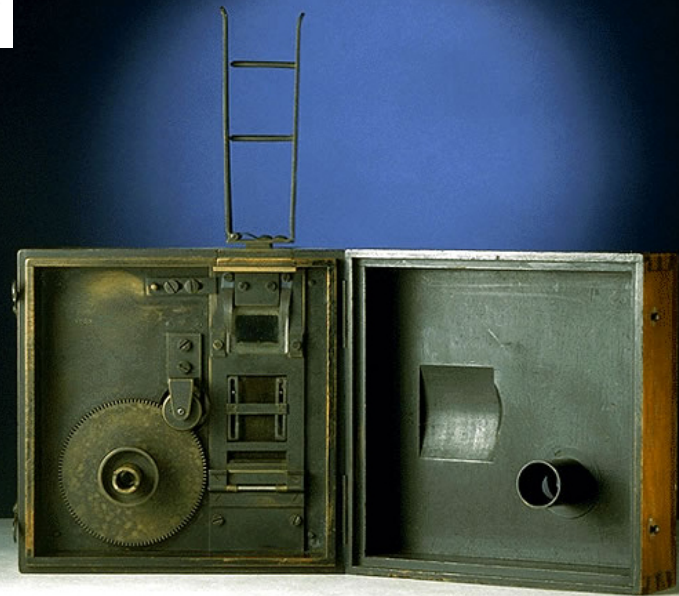

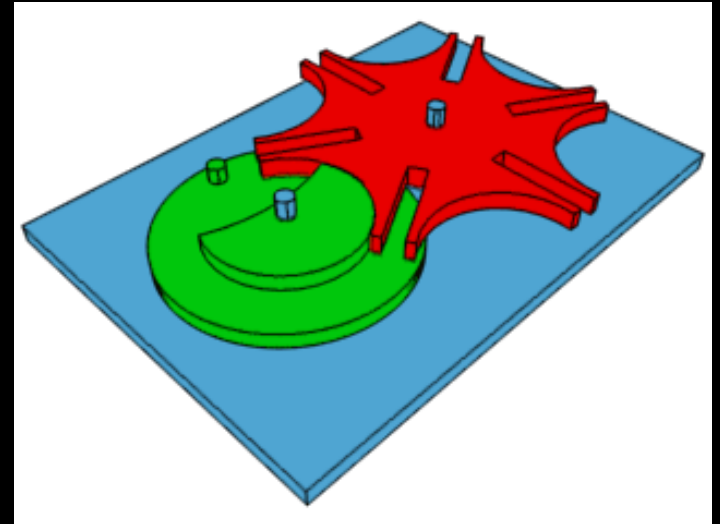
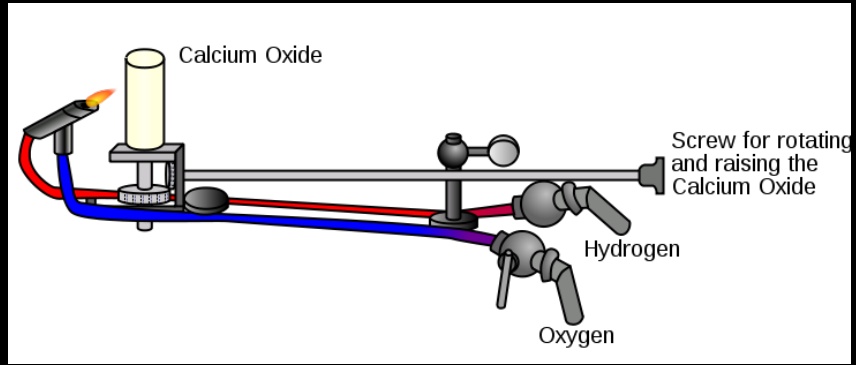
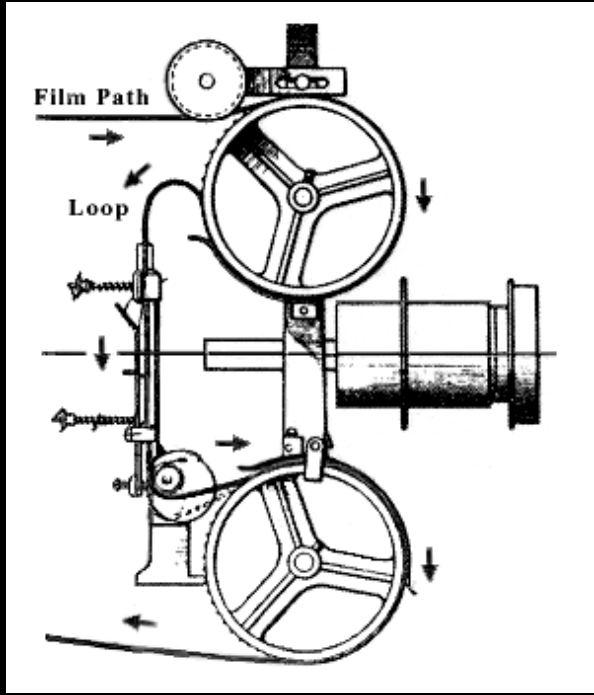

Krupp-Ernemann, 1912

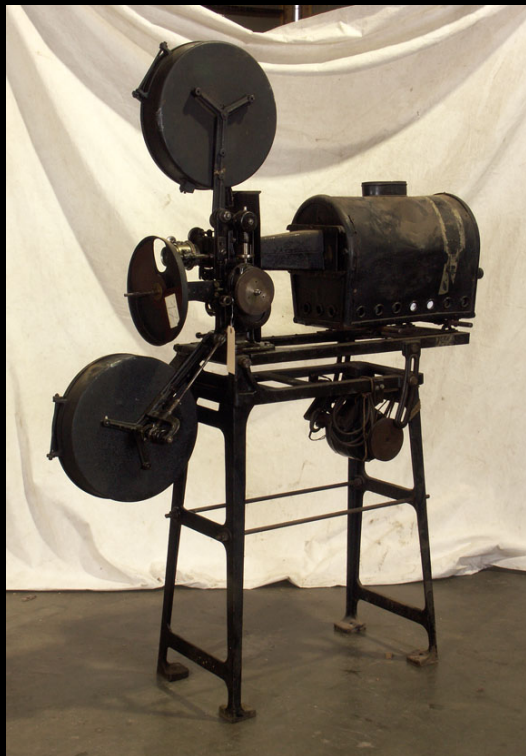

Bauer, 1914



# Standardizace před nástupem zvuku



## Výrobci:

- ➔ Motiograph
- ➔ Simplex (1909)
- ➔ Ernemann (Německo)
- ➔ Kalem (VB),
- ➔ Philips (Nizozemí),
- ➔ Cinemecannica a Prevost (Itálie)



# Nástup zvuku a ustálení



Bauer, 1935



Victoria, 1953



# Přizpůsobování poválečnému vývoji



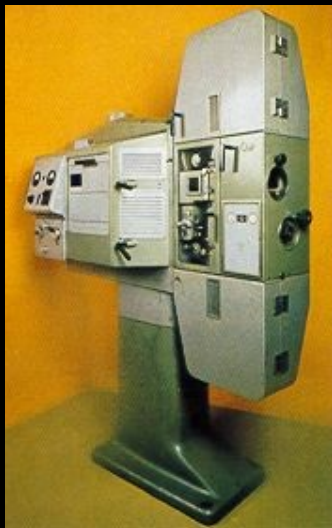

Eta 7 (1947)



Meopton III (1955)



Meopton IV (1959)



UM 70/35 (1963)



Meo 5X (1978)

# Snižování nákladů v kinech



# Platter

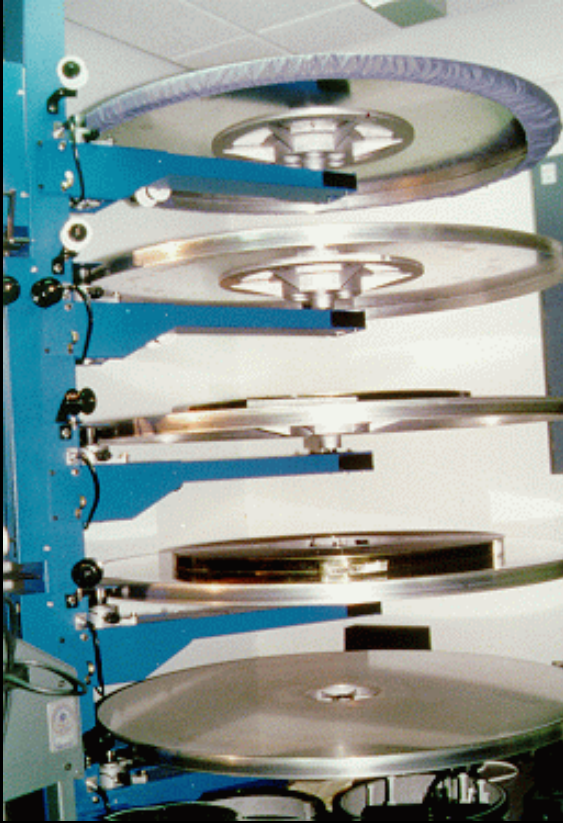

# Multiplex a po něm

