

Ondřej Štochl

TETRALOG

pro
violoncello a elektroniku

Vysvětlivky

Violoncello

Scordatura C – F (ladění strun – F, G, d, a)



- rychlé střídání napsaných flageoletů v různém pořadí



- col legno se zakrytými strunami (výška tónu je určena vzdáleností smyčce od kobylky)



- pizzicato levou rukou

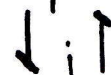

- prudké dohmátnutí prstu levé ruky (musí znít uvedený tón)



- tremollo sul tasto při jemně zakrytých strunách (má znít šum)



- přetlačit strunu F (tzn. přeladěnou C), výška tónu musí být co nejméně zřetelná



- čtvrttón nahoru / dolů

Elektronika - part ovládá zvukař na místě



- použití harmonizéru



- použití dozvuku



- zesilování amplifikace



- zeslabování amplifikace

----- - nechat znít dozvuk, dále sólistu nesnímat

Track 1



- spustit uvedenou stopu

Výše uvedené značky se vzájemně kombinují, smysl těchto kombinací lze vyrozumět z vysvětlení jednotlivých značek

Tetralog

- I. **Sangvinik, který občas - melancholicky – podléhá svým emocím**
- II. **Flegmatik, který dovede být – cholericky – prchlivý**
- III. **Cholerik, jehož projev má i špetku – sangvinické – racionality**
- IV. **Melancholik, který, ovládn emocemi, hledá stabilitu flegmatika**

Durata cca. 14 minut

$\text{♩} = 80$

non vibrato
molto tenuto

$\text{♩} = 9/8$

$\text{♩} = 12/8$ s.p.

vcl.

Violin staff with musical notation. It begins with a treble clef and a 9/8 time signature. The music consists of a series of eighth and sixteenth notes. Dynamic markings include *p* and *pp*. There are also some slurs and accents.

hall ca. 20 sec.

el.

Electric guitar staff with musical notation. It starts with a treble clef and a 9/8 time signature. The notation includes chords and single notes. Dynamic markings include *mp*, *p*, and *pp*. There are also slurs and accents.

Orchestra staff with musical notation. It begins with a treble clef and a 9/8 time signature. The music features various rhythmic patterns and dynamic markings such as *p* and *pp*. There are also slurs and accents.

Orchestra staff with musical notation. It starts with a treble clef and a 4/4 time signature. The notation includes chords and single notes. Dynamic markings include *p* and *pp*. There are also slurs and accents.

Orchestra staff with musical notation. It begins with a treble clef and a 9/8 time signature. The music consists of eighth and sixteenth notes. Dynamic markings include *p*. There are also slurs and accents.

Orchestra staff with musical notation. It starts with a treble clef and a 5/8 time signature. The notation includes chords and single notes. Dynamic markings include *p* and *mp*. There are also slurs and accents.

pp

Handwritten musical notation on a staff with a treble clef. The key signature has one flat (B-flat). The piece starts with a dynamic marking of *p* (piano) and a 5/8 time signature. It features a melodic line with slurs and a fermata over a note. The dynamic changes to *mp* (mezzo-piano) for a section with a 6/8 time signature and a 5-measure phrase. It concludes with a 5/8 time signature and a dynamic marking of *p*. Below the staff is a hatched bar representing a performance duration.

Handwritten musical notation on a staff with a treble clef. The key signature has one flat. It begins with a 5/8 time signature and a dynamic marking of *mp*. The notation includes triplets and a 4/8 time signature section. It ends with a 3/8 time signature and a dynamic marking of *p*. Below the staff is a hatched bar representing a performance duration.

Handwritten musical notation on a staff with a treble clef. The key signature has one flat. It starts with a dynamic marking of *mf* and a 3-measure phrase. This is followed by a section with a 4/4 time signature and a note marked with a fermata, with the instruction "(než skončí doz ruk)" written above. The dynamic then changes to *p*. The piece concludes with a 7/8 time signature and a dynamic marking of *p*. Below the staff is a hatched bar representing a performance duration.

Handwritten musical notation on a staff with a treble clef. The key signature has one flat. It features a 10/8 time signature and a dynamic marking of *mf*. The notation includes a 11/8 time signature section and a 9/8 time signature section. The dynamic changes to *p* towards the end. Below the staff is a hatched bar representing a performance duration.

Handwritten musical notation on a staff with a treble clef. The key signature has one flat. It starts with a dynamic marking of *ppp* (pianissimo) and a 9/8 time signature. The notation includes a 3/8 time signature section and an 8/8 time signature section. The dynamic changes to *p*. Below the staff is a hatched bar representing a performance duration.

Handwritten musical notation on a staff with a treble clef. The key signature has one flat. It begins with a 11/8 time signature and a dynamic marking of *p*. The notation includes a 9/8 time signature section and a 13/8 time signature section. Below the staff is a hatched bar representing a performance duration.

mf

6/8

molto vibr.

Handwritten musical notation on a grand staff. The upper staff contains a melodic line with various accidentals and a fermata. The lower staff is mostly empty with some hatching. Dynamics include "poco mf".

Handwritten musical notation on a grand staff. The upper staff has a melodic line with a slur and a fermata. The lower staff has a complex rhythmic pattern with many notes. Dynamics include "mf, pp".

Handwritten musical notation on a grand staff. The upper staff has a melodic line with a tempo marking "♩ = 60" and a dynamic "poco f". The lower staff has a melodic line with triplets and a dynamic "mp". Includes the instruction "hall cca. 40 sec.".

Handwritten musical notation on a grand staff. The upper staff has a hatched box. The lower staff has a melodic line with triplets and a dynamic "f". Includes the instruction "decrecendo".

♩=70 $\text{G}(\sharp)$ II $\text{G}(\sharp)$ $\text{G}(\sharp)$

5/1 5 5 5 5 5 3/1 7 7 5

pp *p*

$\text{G}(\sharp)$ $\text{G}(\sharp)$ $\text{G}(\sharp)$ $\text{G}(\sharp)$

9/1 6/1 5 5 5 5

mp *p*

$\text{G}(\sharp)$ $\text{G}(\sharp)$ $\text{G}(\sharp)$ $\text{G}(\sharp)$

2/1 6/1 5/1 3/1

pp *mf* *p* *mf* *p* *mf* *pp*

$\text{G}(\sharp)$ $\text{G}(\sharp)$ $\text{G}(\sharp)$

9/1 3/1 7/1 3/1

f *mp* *f*

$\text{G}(\sharp)$ $\text{G}(\sharp)$

9/1 5/1 6/1

mp *p* *mp*

Handwritten musical notation on a single staff. The piece begins with a *mf* dynamic. It features a 9/8 time signature and a 6/8 time signature. A triplet of eighth notes is marked with a '3' and a '+' sign. The notation includes various note values, rests, and slurs. The bottom of the page is shaded with diagonal lines.

Two chord diagrams in parentheses, each with a sharp sign and a double bar line below it, representing specific chord voicings.

Handwritten musical notation on a single staff. It starts with a 3/4 time signature and a 4/4 time signature, marked *poco s.p.* with a *p* dynamic. It then changes to a 7/8 time signature, marked *Più mosso; J = 100* and *vibrato*, with a *mf* dynamic. The notation includes slurs, accents, and a final measure with a '+' sign. The bottom of the page is shaded with diagonal lines.

Handwritten musical notation on a single staff. It begins with a 3/4 time signature and a triplet of eighth notes, marked *tr.* and *b*. It then changes to a 9/8 time signature, marked *rit.* with a *p* dynamic. The notation includes slurs and accents. The bottom of the page is shaded with diagonal lines.

Handwritten musical notation on a single staff. It starts with a 7/8 time signature, marked *J = 70* and *pizz.* with a *mp* dynamic. It includes *arco* and *tr.* markings. It then changes to a 3/4 time signature, marked *[cd]* with a *mf* dynamic. A chord diagram is shown above the staff. The bottom of the page is shaded with diagonal lines.

Handwritten musical notation on a single staff. It begins with a 5/4 time signature, marked *Più mosso J = 100* and *poco f* with a *p* dynamic. It features a triplet of eighth notes. It then changes to a 2/4 time signature and a 3/4 time signature, marked *f* and *mp*. The notation includes slurs, accents, and a final double bar line. The bottom of the page is shaded with diagonal lines.

7 4/8 1 3 3/8 [d:] p

f mp mf p

($\begin{matrix} 0 & 0 \\ \bullet & \bullet \\ \text{F}\# & \text{A} & \text{C} \end{matrix}$)

3 3 3 3/8 [d:] ritenuto

mp poco f

5/4 6 6 6 6 6 3 J=70

mp mp

4/8 pizz. + 3/8 6/8

p pp p

3/8 4/8 5 3/8

p mp p

Handwritten musical notation on a single staff. It begins with a treble clef and a key signature of one flat. The first measure contains a half note chord with a dynamic marking of *mp* and a hairpin crescendo. The second measure has a *5/d* fingering and a *cch* marking above it, with a slur over the notes. The third measure has a *3* above it and a *p* dynamic with a hairpin decrescendo. The fourth measure has a *1* above it and a *p* dynamic with a hairpin decrescendo. The staff ends with a double bar line and a fermata.

Handwritten musical notation on a single staff. It starts with a treble clef and a key signature of one flat. The first measure has a *4/d* fingering, a *1* above it, and a *p* dynamic with a hairpin decrescendo. The second measure has a *3* above it. The third measure has a *5/d* fingering. The fourth measure has a *5/d* fingering, a *ritenoto* marking above it, and a *p* dynamic with a hairpin decrescendo. The fifth measure has a *5* above it. The sixth measure has a *5* above it. The staff ends with a double bar line and a fermata.

Handwritten musical notation on a single staff. It begins with a treble clef and a key signature of one flat. The first measure has a *6/d* fingering and a *pp* dynamic with a hairpin decrescendo. The second measure has a *7/d* fingering, a *5* above it, and a *p* dynamic with a *decresc.* marking. The third measure has a *5* above it. The fourth measure has a *4/d* fingering, a *5* above it, and a *p* dynamic with a hairpin decrescendo. The fifth measure has a *5* above it. The staff ends with a double bar line and a fermata.

Handwritten musical notation on a single staff. It starts with a treble clef and a key signature of one flat. The first measure has a *6/d* fingering and a *ppp* dynamic with a hairpin decrescendo. The staff ends with a double bar line and a fermata.

6 sec. sfz
10 sec. 
4 sec.

vcl. 

el. 

rack 

1

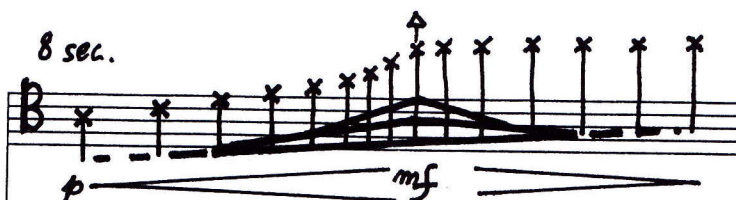
8 sec. 

5 sec. 

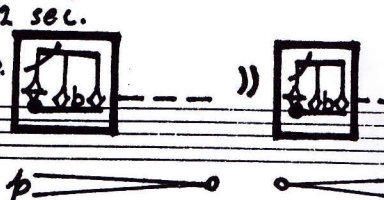
12 sec. mp
s.p. 

hall 5 sec. 

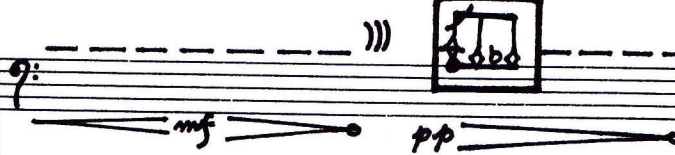

4 sec. 

$\text{♩} = 90$
 ∞

hall 



p 

s.p. 

8 sec. 

hall 8 sec. 

1 + 2

2

9 sec.

Handwritten musical notation in a box, possibly a chord or specific interval.

)))

Handwritten musical notation in a box, similar to the first one.

$\text{♩} = 80$

pizz.

vcl.

pp

track

3

mp

rit.

mp

$\text{♩} = 80$

6 sec.

3/4

mf

mp

poco accel.

3x

7/8

sfz

2/4

mf

f

half 10 sec.

rit.

$\text{♩} = 80$

7/8

arco

3/4

sfz

2/4

4/4 pizz.

ff

mp

pocof

pocof

cl. *arco*
3/4 *mf* 3 6 *poco f* 4/4 *mp* 5

el.

7/8 *poco f; mp* *be.* 9/8 *pizz.* *f* 5/4 *arco* *mp* 3

3 5/4 *poco f* 4/4 *tenuto* *f* *p*

7/8 *f* 6/8 *pizz.* *mp* 4/4 *arco* 6

poco f 7/8 *f* *sfz* 4/4 *mf* 5

Handwritten musical notation for the first system. It begins with a treble clef and a 5-measure slur over a sequence of notes. The first measure is marked with a forte *f* dynamic. The second measure is marked with a 9/8 time signature and the instruction *tenuto*. The third measure is marked with a mezzo-piano *mp* dynamic. The fourth measure is marked with a 9/8 time signature and a piano *p* dynamic. The fifth measure is marked with a sforzando *sfz* dynamic. The system concludes with a double bar line. Below the staff is a hatched area representing the piano accompaniment.

Handwritten musical notation for the second system. It begins with a treble clef and a 3-measure slur over a sequence of notes, marked with a forte *f* dynamic. The second measure is marked with a 3/8 time signature and the instruction *tenuto*. The third measure is marked with a fortissimo *ff* dynamic and a piano *p* dynamic. The fourth measure is marked with a 9/8 time signature and a fortissimo *ff* dynamic. The system concludes with a double bar line. Below the staff is a hatched area representing the piano accompaniment.

Handwritten musical notation for the third system, presented as a grand staff. The upper staff is for violin (*vcl.*) and the lower staff is for electric guitar (*el.*). The violin part begins with a 2/4 time signature and a forte *f* dynamic. The second measure is marked with a 11/8 time signature and a sforzando *sfz* dynamic. The third measure is marked with a 7-measure slur. The fourth measure is marked with a 5/4 time signature and a fortissimo *fff* dynamic. The system concludes with a double bar line and the instruction *sfz possibile*. The electric guitar part is mostly silent, with a few notes in the second measure. Below the staff is a hatched area representing the piano accompaniment.

♩ = 150

IV.

5/♩ tr. sempre 3/♩ 4/♩ 5/♩ (tr. sempre)

L. *f*

R. *mf* *s.p. (tr.)* *mp* *p* *f*

vcl.

el.

4/♩ 5/♩ tr. 4/♩

vcl. *mp* *f*

el. *f* *mp* *f* *p* *mp* *f* *mp*

vcl.

el.

3/♩ 5/♩ 8/♩ 6/♩

vcl. *mf* *p* *mf* *f* *ff* *mf* *f*

el. *mf* *f* *p* *mf* *f* *ff* *mf* *f*

vcl.

el.

3/♩ 7/♩ rit. 6/♩ tr.

vcl. *f* *p* *mp* *f*

el. *f* *p* *mp* *f*

vcl.

el.

5/♭ senza tr. + 3/♭ + 5/♭ 7/♭ tr. b +

(+)mf mf mp

5/♭ + + 3/♭ 5/♭

(+)mf mf f ff p

4/♭ 8/♭ 5/♭

mf ff

7/♭ 6/♭ + + 4/♭ + 5/♭

mf ff p f

3/4
mp

4/4
mf

molto accel.
5/4

(arco)

mp

mf

9/8
mf

7/8

3x
3/8

poco f

f

4/4
suld
sfz
ff

7/8
+++++

d.

60

9/8 + 1/8
p

sim.

5/4
mp

non vibr.

pp

2/4

vcl.

arco s.p.

Pizz.

mp

3

7/8

el.

arco ord.

mp

3

5/4

s.p.

mp

p

ord.

mp

mf

11/8

3/4

9/8

mf

4/4

5/4

pp

p

mp

2/4

3/4

7/4

3/4 0 000 0 *flag. simile* 8 sec. ∞

vcl.

el.

vcl.

5/4 10 sec. ∞

pizz. arco *

el.