

sklo

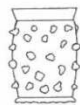

I.1



I.4



I.8



I.11



I.15

### Číška s optickým dekorem

### Hladké číšky

### Číše českého typu



I.16



I.18



II.3



II.4



II.5



II.7

### Číše s prohnutým okrajem



II.11

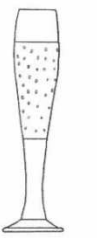

II.12



II.13



II.14



II.17



II.18

Dekor: diagonálně natavená vlákna

Dekor: tažené kapky

### Číše kyjovité

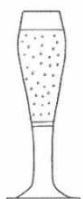

II.20



II.19



II.24



II.25



II.26



II.27



III.2



III.3



III.4



IV.2







XII.

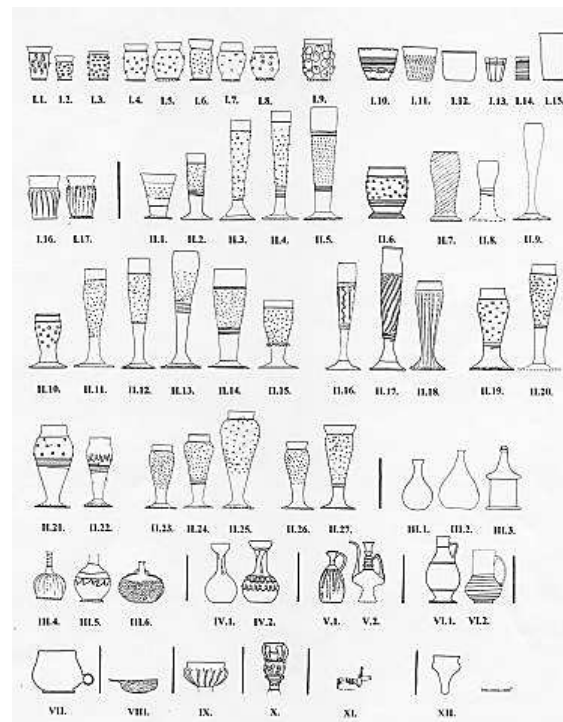

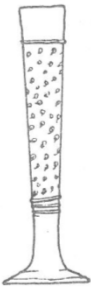
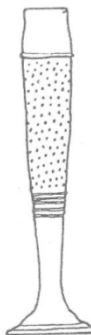
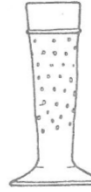
XIII.

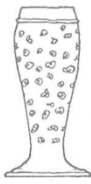

Typ	Obr.	13.stol.	14.stol.	15.stol.
I/1			<b>Číše českého typu</b>	
I/2				
I/3				

Typ	Obr.	13.stol.	14.stol.	15.stol.
I/4				
I/5				
II				
III				
IV/1				

**Široké kyjovité číše**







**Číše s taženými kapkami**

**Číše s nálepy**

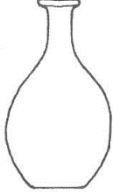
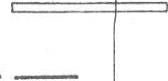
Typ	Obr.	13.stol.	14.stol.	15.stol.
IV <sub>2</sub>				
IV <sub>3</sub>				
V		<b>Široká kónická číška s velkými nálepy</b>		
VI				 <b>miska</b>
VII				
VIII				

**Kónický pohár předfouknutý do formy s vpíchnutým dnem**

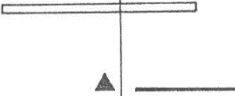

**Válcovité číše předfouknuté do formy: zdobené žebry**

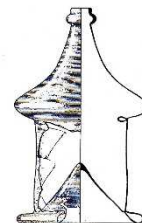
Typ	Obr.	13.stol.	14.stol.	15.stol.
IX				 <b>Hladká láhev s kulovitým tělem: vpíchnuté dno ±plastický pásek</b>
X				 <b>láhev splastickými žebry: vpíchnuté dno+plastický pásek</b>
XI				 <b>kutrolf</b>
XII				 <b>Dvojkónická láhev</b>



**Lahev s vnitřním prstencem: Doppelflasche**

**13.-15.stol. Morava**

Typ	Obr.	13.stol.	14.stol.	15.stol.
XIII			—	
XIV		—		
XV		▲	—	

konvičky

2.1 Počátky středověkého sklářství v Čechách a na Moravě

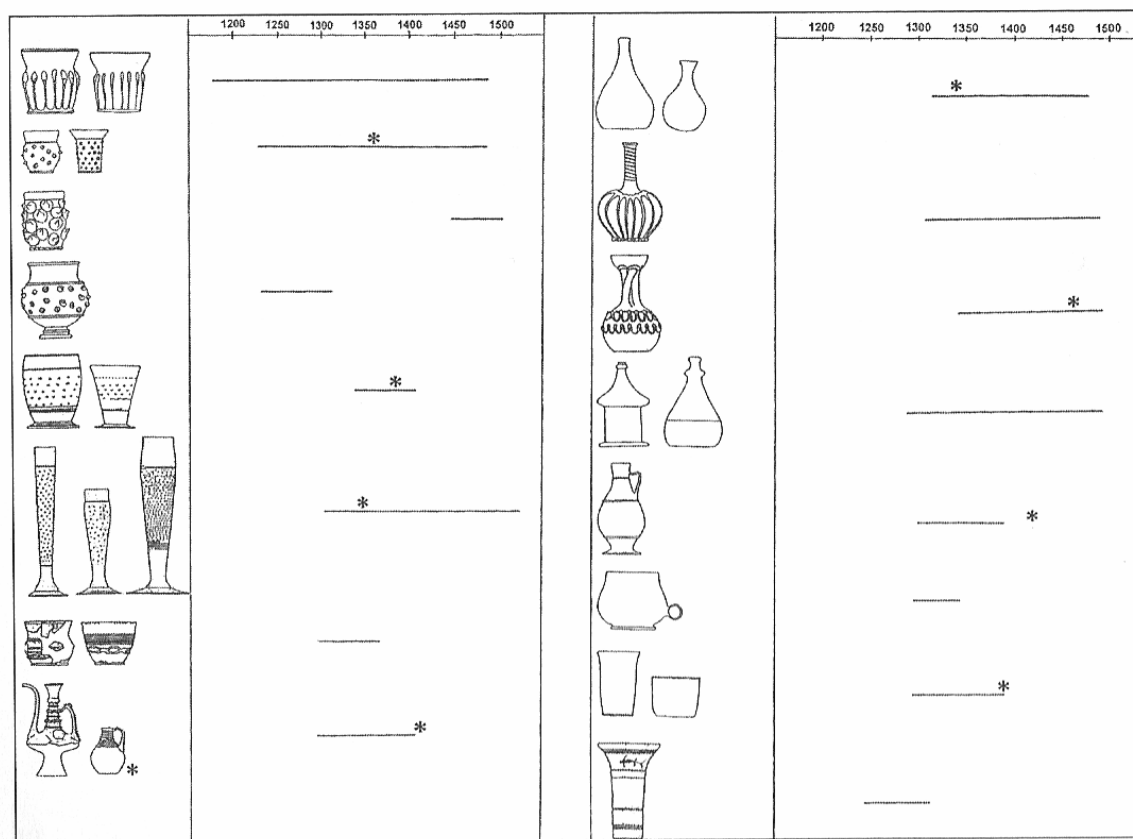

2 Srovnání výskytu archeologicky doložených tvarů nádob s dobou jejich nejstaršího vyobrazení v pramenech ikonografických.

## 1. Schenkgefäße – stolovací nalévací nádoby



I.1.

- I.1. Konvice
- I.2. Džbán
- I.3. Stolní lahev

- I.3.1. typ Mečová ulice 2
- I.3.2. s šikmým žebrováním a trychtýřovitým zobáčkem
- I.3.3. s žebrovaným hrdlem

## 2. žebrované nádoby

- II.1. s výraznými rameny
- II.2. hruškovitého tvaru

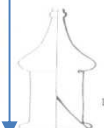
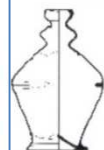
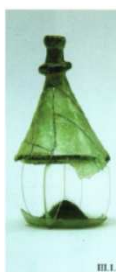

## 3. Lahve s vnitřním prstencem

- III.1. hruškovitého tvaru
- III.2. s kónickou spodní polovinou
- III.3. s cylindrickou spodní polovinou

## 4. číšky

### IV.1. s nálepy



- IV.1.1. s většími oválnými šnekovitými nálepy
- IV.1.2. s většími zašpičatělými nálepy
- IV.1.3. s menšími šnekovitými nálepy
- IV.1.4. s mnohoúhelníkovou kupou
- IV.1.5. sudovitá
- IV.1.6. zvláštní typy



### IV.2. s modrým natavením

- IV.2.1. cik-cak linie
- IV.2.2. s modrým nálepem
- IV.2.3. s bezbarvým nálepem

### IV.3. Hladké

- IV.3.1. s hladkou patkou
- IV.3.2. bez patky
- IV.3.3. s trychtýřovitým okrajem

### IV.4. s optickým dekorem

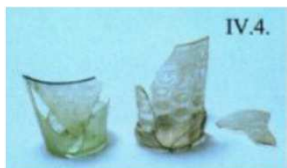

- IV.4.1. se vzorem bodů
- IV.4.2. s žebrovaným vzorem a kónickým tělem
- IV.4.3. s žebrovaným vzorem a soudkovitým tělem

## IV.5. s malovaným dekorem

- IV.5.1. malováno barevným emailem
- IV.5.2. malováno zlatem



## IV.6. se skleněnými žebry/s žebrovanou patkou

- IV.6.1.: Číška s taženými kapkami a modrými zrnky

## IV.7. kyjovitá číše

- IV.7.4. číše kyjovitá se srpekovitými nálepy

## 5. Becher = pohárky

- V.1. s hladkou kupou
- V.2. s žebrovanou kupou/vřetenovitou



## 6. Kutrolfy

## 7. Scheuer = šálky

- VII.1. hladké
- VII.2. s jemným (vertikálním a diagonálním)
- VII.3. s velkým (vertikálním a diagonálním) ž

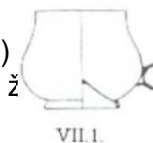

VII.1.

## 8. Zvláštní tvary

- VIII.1. žebrovaná miska
- VIII.2. polokulovitá miska
  - VIII.2.1. s žebry
  - VIII.2.2. hladká
- VIII.3. nádoba s nožkami
- VIII.4. poutnická lahev
- VIII.5. nádobka ve tvaru jelena

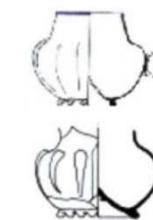

VIII.2.

## 10. Ozdoby

X.

## 11. Okenní sklo



VIII.1.

VIII.2.1.

VIII.2.2.



# Výzdoba skla

- vláknem
- kapkami/nálepky
- nitkováním (filigránová výzdoba)
- optický dekor
- malba
- rytí (diamantem)



**Sklárna Broumy 1599**

S taženými kapkami



staženým vláknem



Typ I.16 číše s vertikálními žebry

Hrotitě vytažené nálepy



Typ I.18

sklo transparentní opáklí





1270-1350

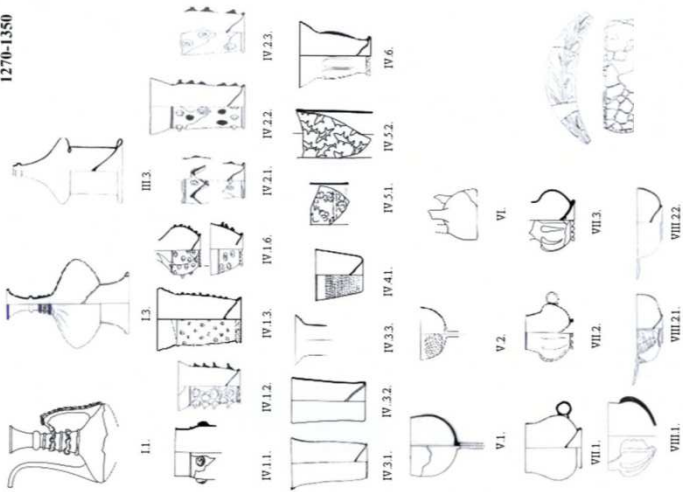

1350-1400

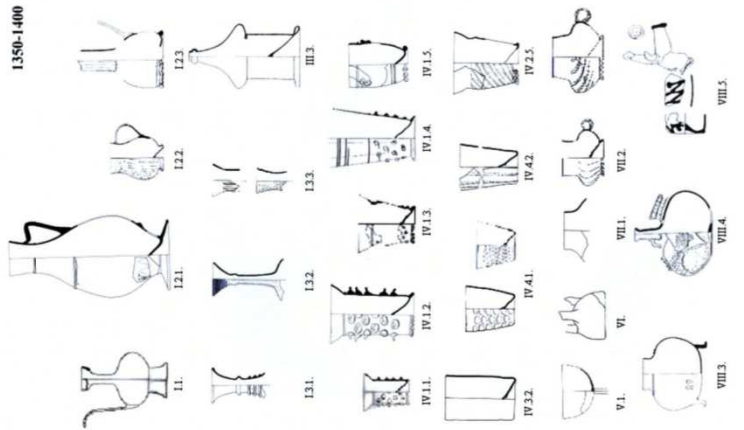

	I.	II.	III.	IV.1.	IV.2.	IV.3.	IV.4.	IV.5.	IV.6.
1240-1270									
1270-1350									
1350-1400									

### Číše Olomouckého typu



### Číše: kyjovitá IV.7.4.

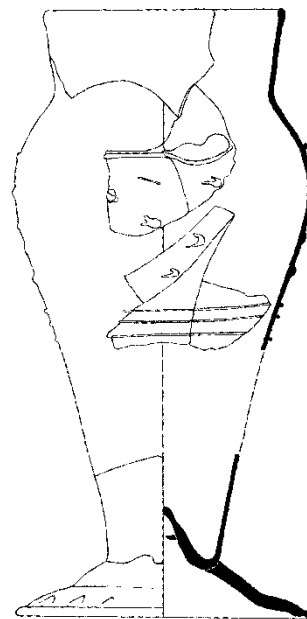

Jihlava

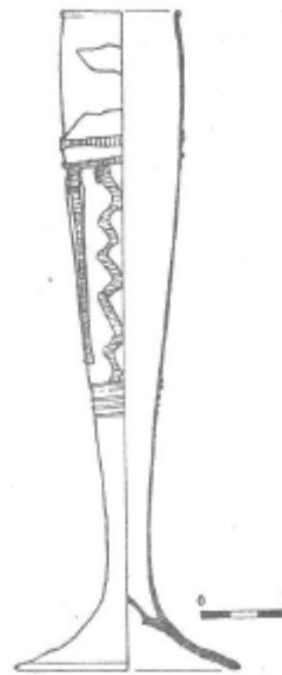

Plzeň

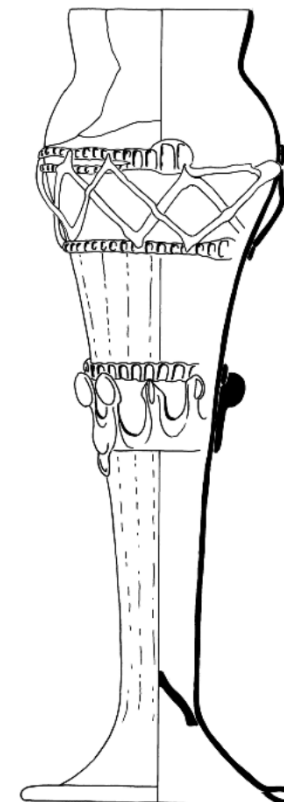

Brno, Olomoc, Opava  
Brno 1450-1480

### Číše s nálepy + vpravo z modrozeleného skla: typ schafhausen



# Dutá skla - stolní

- číše (nemají: stopku/dřík)



- poháry (kupa, stopka/dřík, patka)



römer



krautstrunk



číše českého typu

# Rozdělení skla - Dutá skla – stolní

- lahve a kutralfy
- džbány (mají ucho, ale nikoliv výlevku)
- konvice (mají výlevku)
- holby
- mísy
- talíře
- pokličky

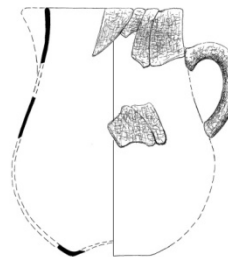
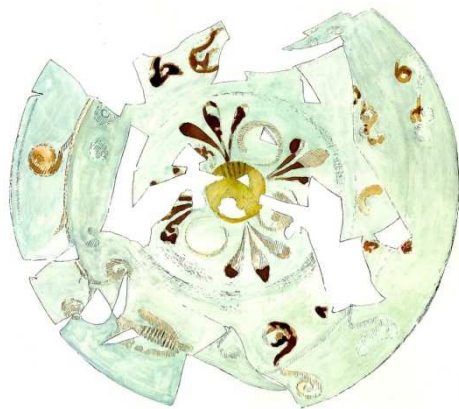
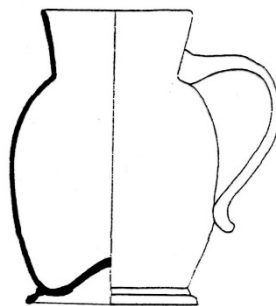
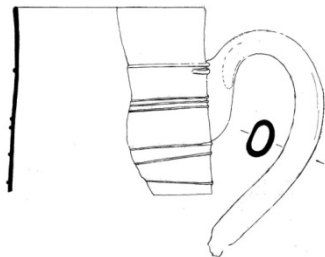
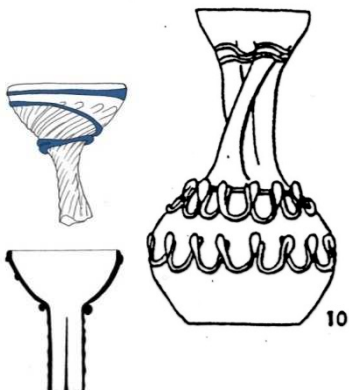



# Dutá skla

- hygienická - urinaly
  - tzv. mucholapky
- laboratorní - destilační předměty
  - alembiky
  - arbarela
  - lékárenské/kosmetické nádoby
- žertovné nádoby
  - varia – lampy
  - kalamáře

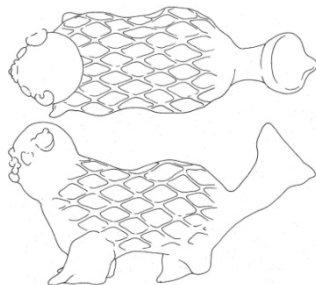
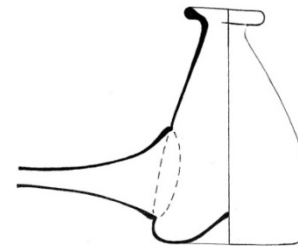
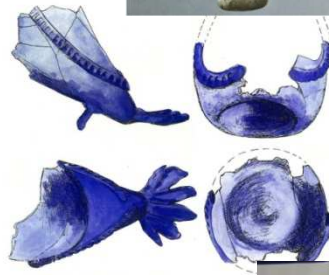
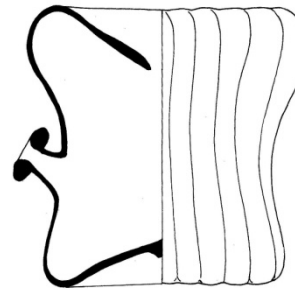
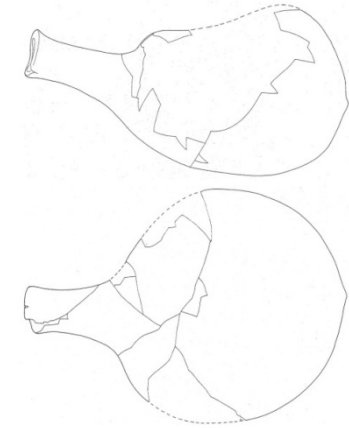
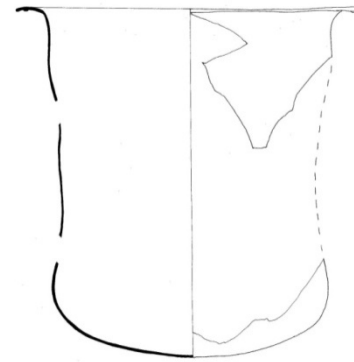



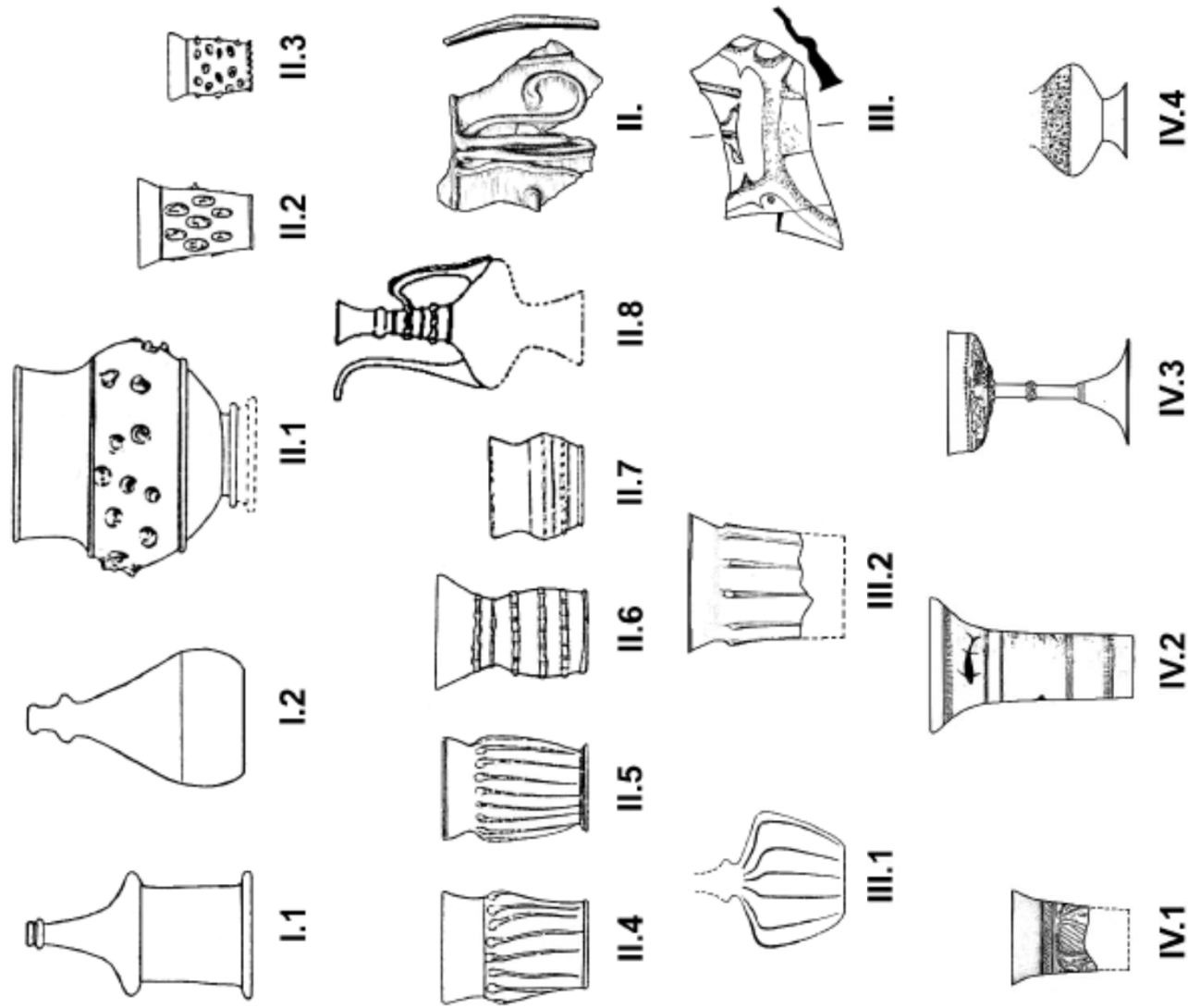

Obr. 7. Schematizované tvary nádob 12.–13. století z území Čech. I – foukané z volné ruky, nezdobené; II – foukané z volné ruky, zdobené natavenými nálepy a vláknky; III – foukané do pevné formy; IV – foukané z volné ruky, malované zlatem, zlatem a emaily nebo jen emaily (kresba H. Jonášová, J. Smržová).

Brno 1240-1270

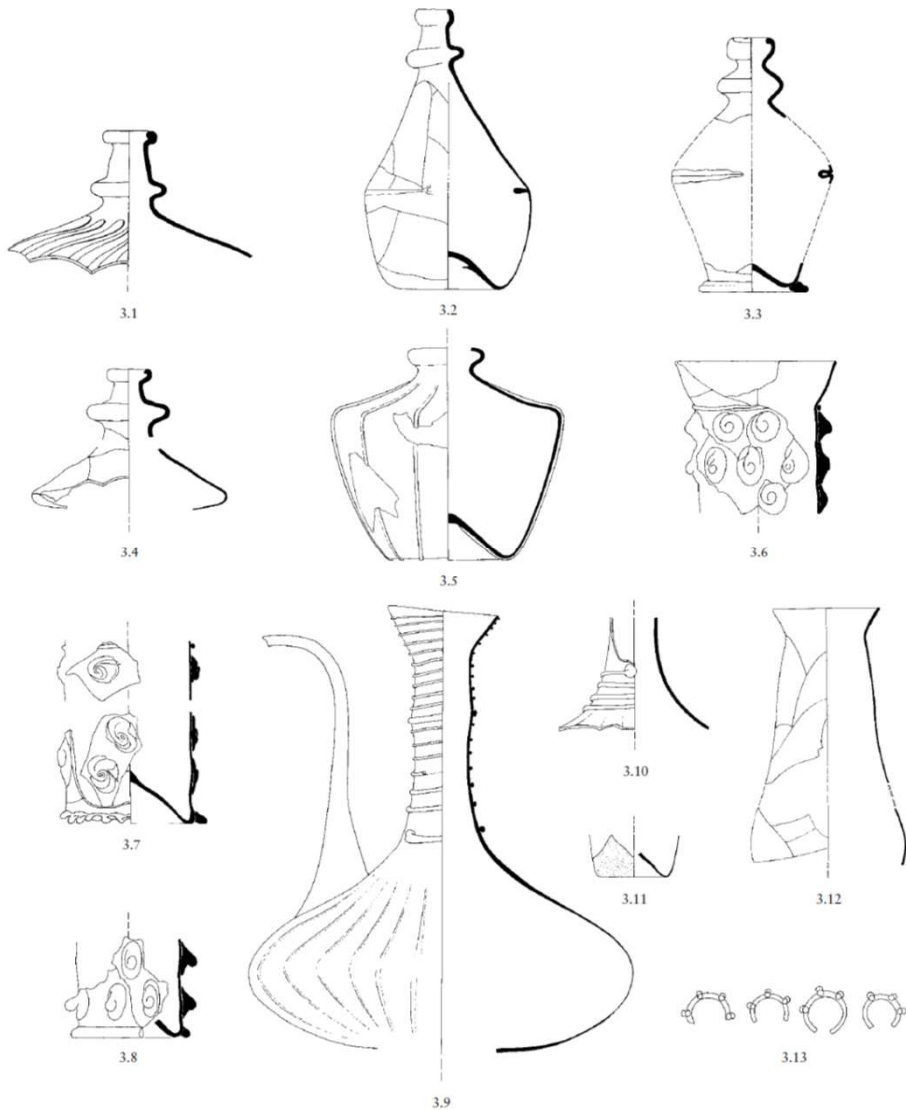

hnědé sklo



zelené sklo



žluté sklo



Čiré sklo s modrou nití



# Brno 1270-1350

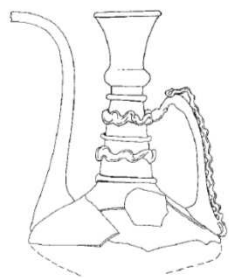

4.1

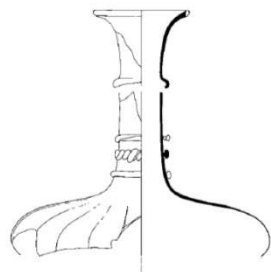

4.2

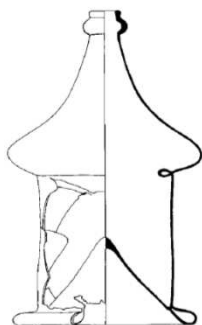

4.3

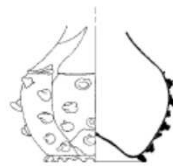

4.8

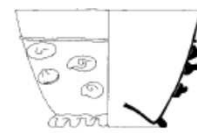

4.9



4.10

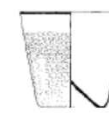

4.11

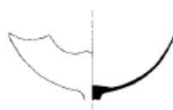

4.12

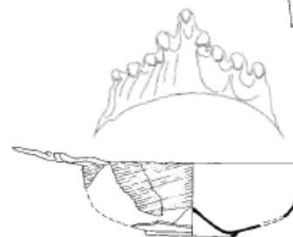

4.14

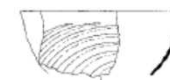

4.13



4.4



4.5

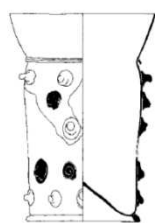

4.6

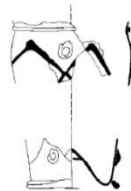

4.7



4.15

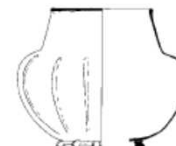

4.16



4.17

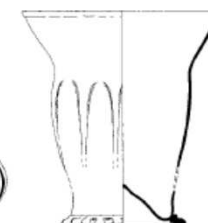

4.18

# Brno 1350-1420

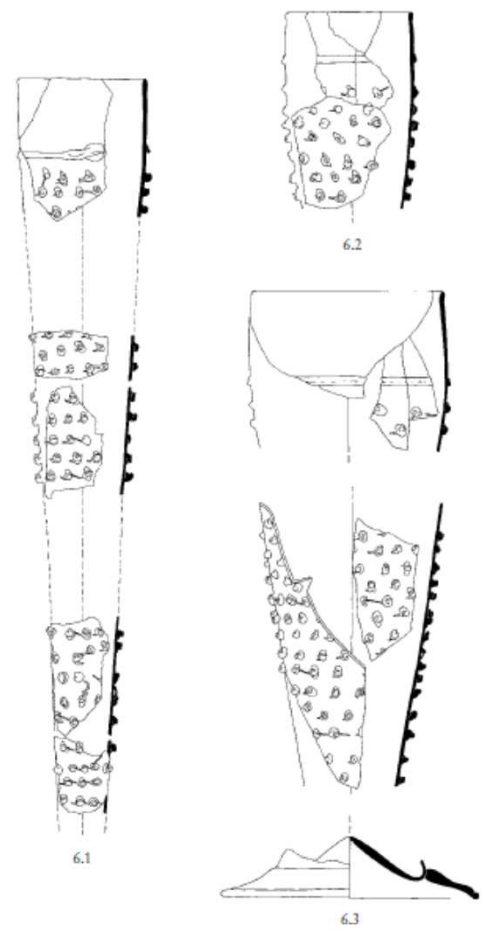
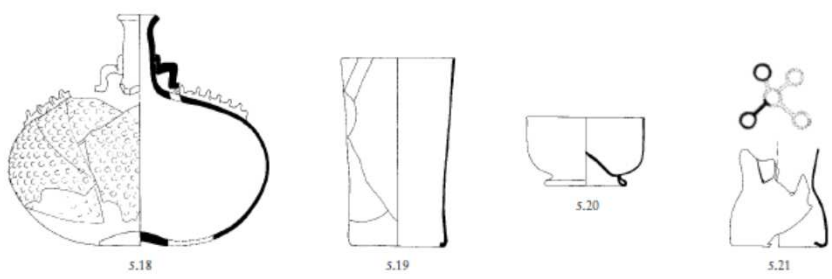
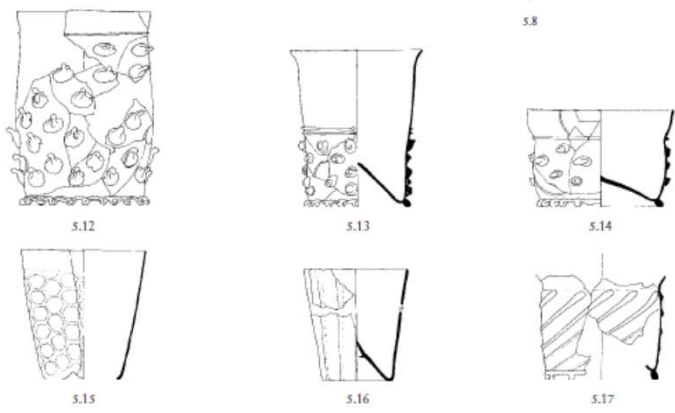
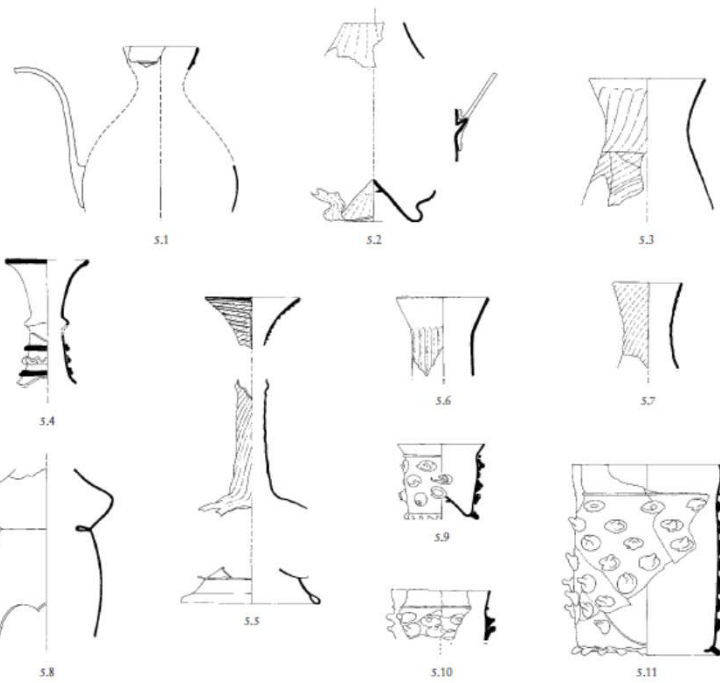

Brno 1421-1428

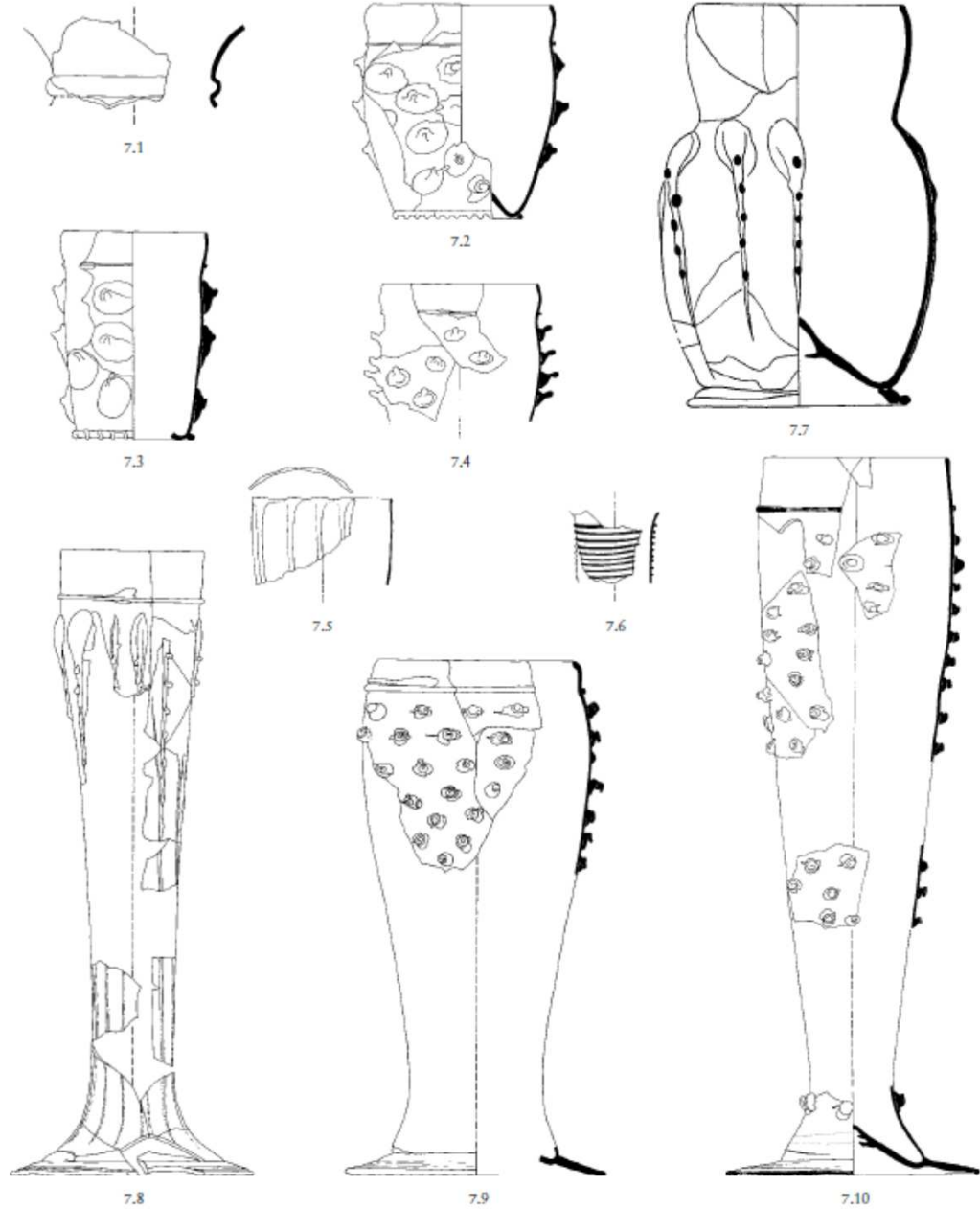



# Brno 1420-1470

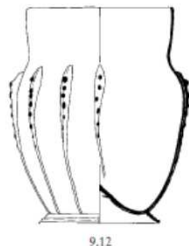
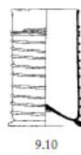
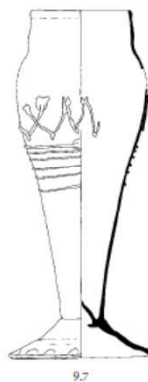
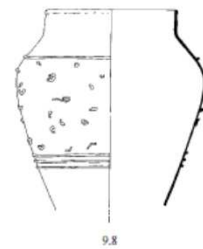
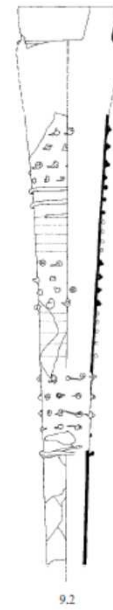
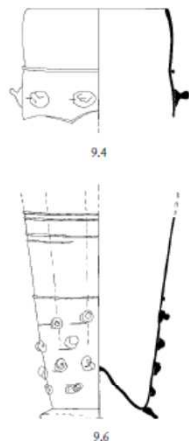
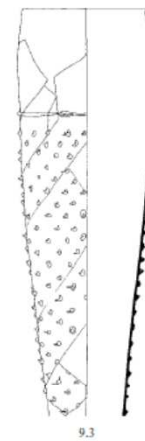
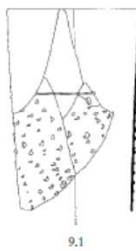
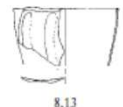
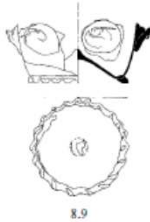
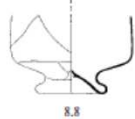
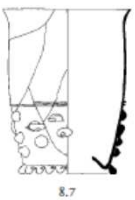
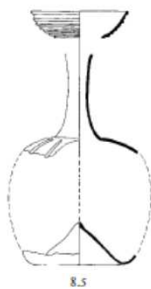
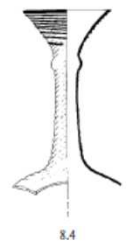
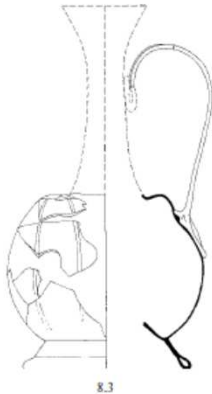

Brno 2/2. 15. stol.

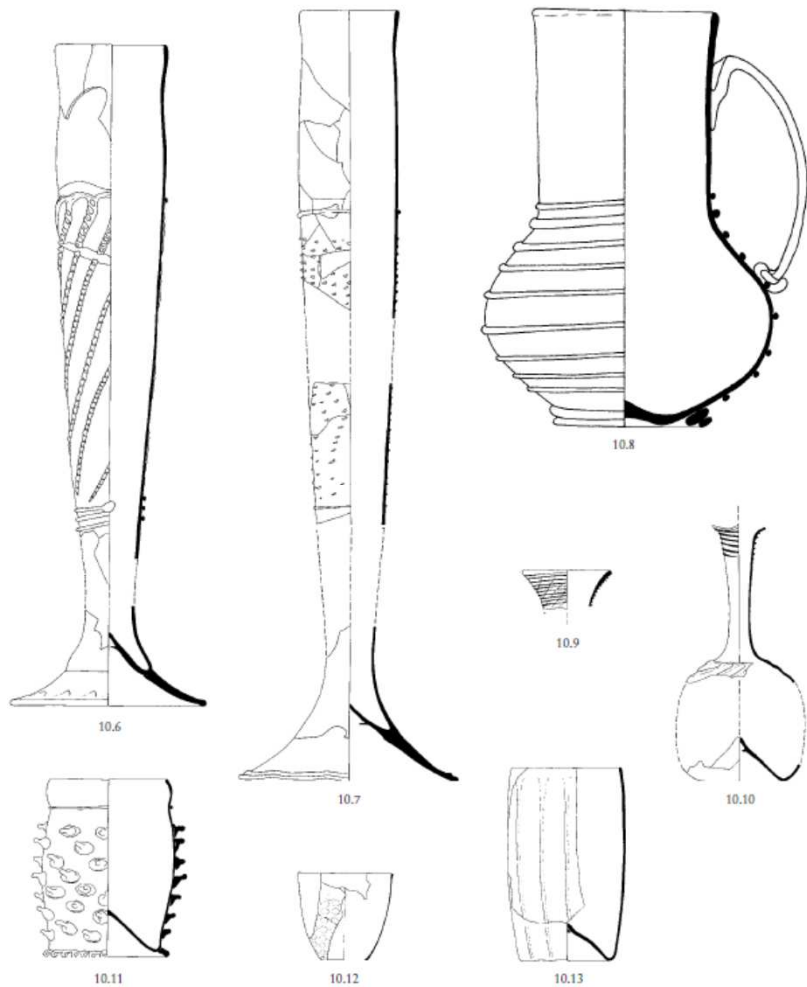

Emailový pohár



1500-1560

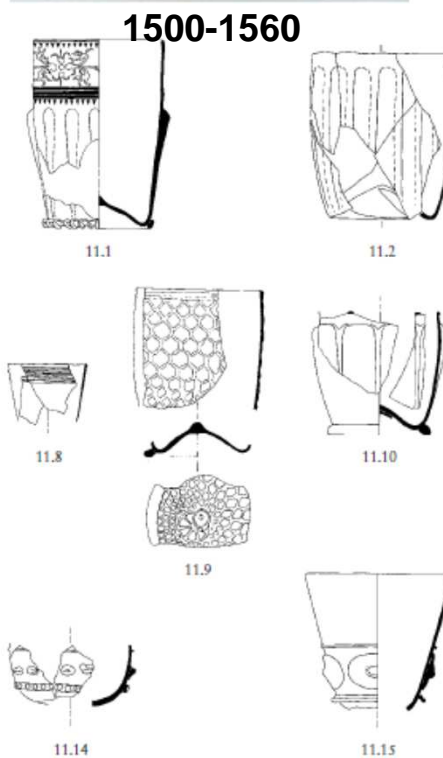

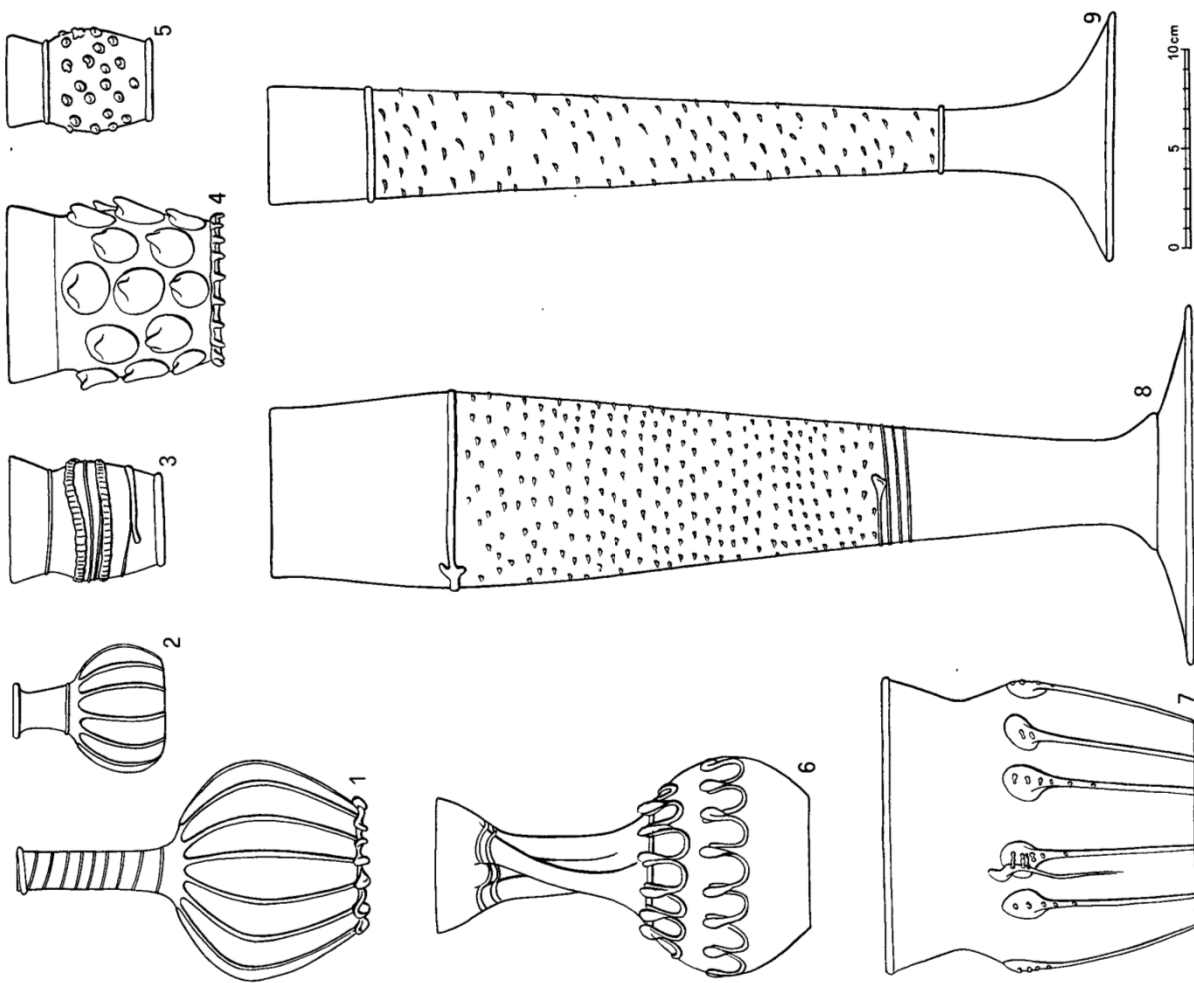

Obr. 7. Pížeň — Solní ul. Základní typové zastoupení skleněných nádob.

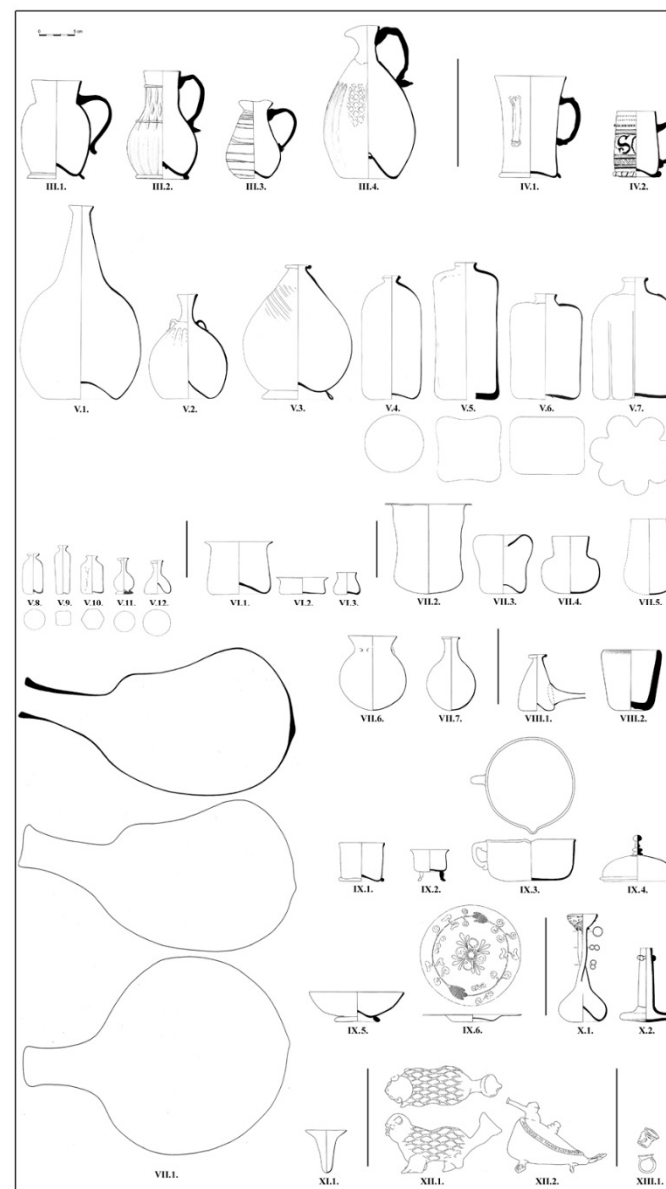
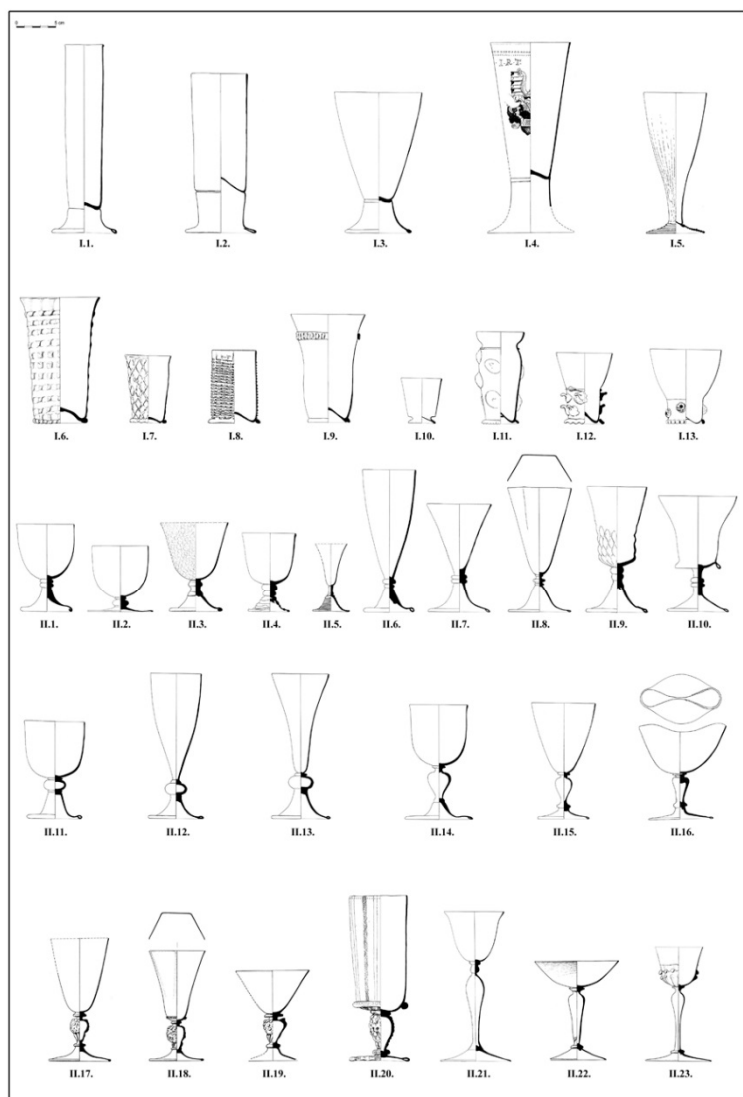

**Typy skla 16.-17. století, nalezeného na Pražském hradě a Hradčanech**

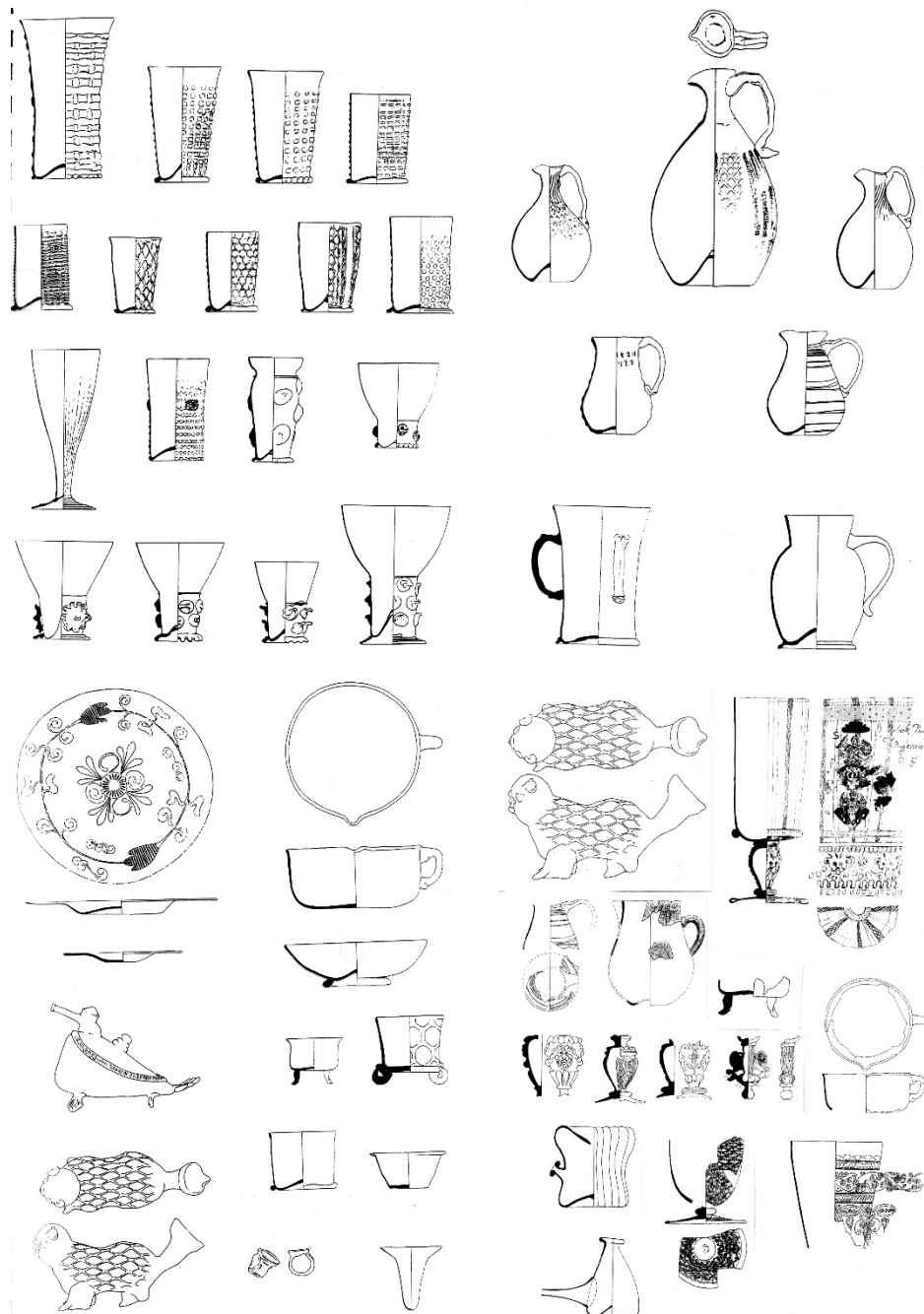

Tab. 9. Most, čp. 226. Schématicizované tvary nádob zastoupené v horizontech I–V. Kresby tab. č. 2–6 a 9 H. Jonášová.





**Fig. 14.** Types of vessels in Bratislava from 13<sup>th</sup> – mid- of 15<sup>th</sup> century. **1–3** = 13<sup>th</sup> century; **4–15** = end of 13<sup>th</sup>–14<sup>th</sup> century; **16–18** = mid- of 15<sup>th</sup> century. Drawn by H. Sedláčková, technical support L. Sedláčková. — **Obr. 14.** Typy nádob ze 13. až poloviny 15. století. **1–3** = 13. stol.; **4–15** = koniec 13.–14. stol., **16–18** = do poloviny 15. stol. Kresba: H. Sedláčková, technická úprava L. Sedláčková.

