

△ A conjectural reconstruction of the theatre of Dionysus in the early fifth century BC. It is possible that there was no *skene* at all at this time. The temple of Dionysus is on the right.

▽ The theatre of Dionysus in the second half of the fifth century. The *skene* at this time must have been made of wood. The arrangement shown here has three doorways and the actors can appear on the roof. The Odeon of Pericles is in the background.

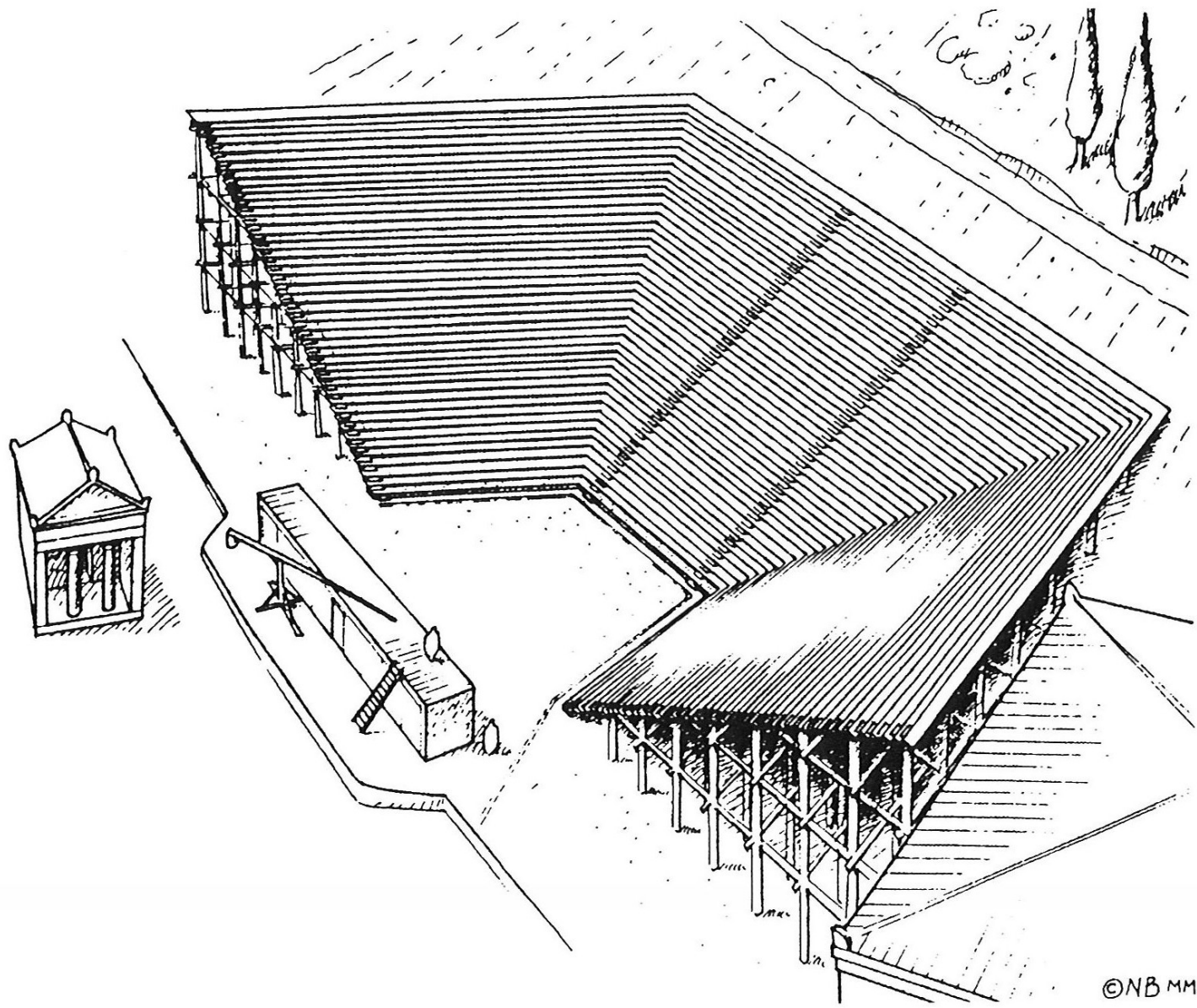





Dionýsovo divadlo, Athény, pol. 5. stol. př. n. l.

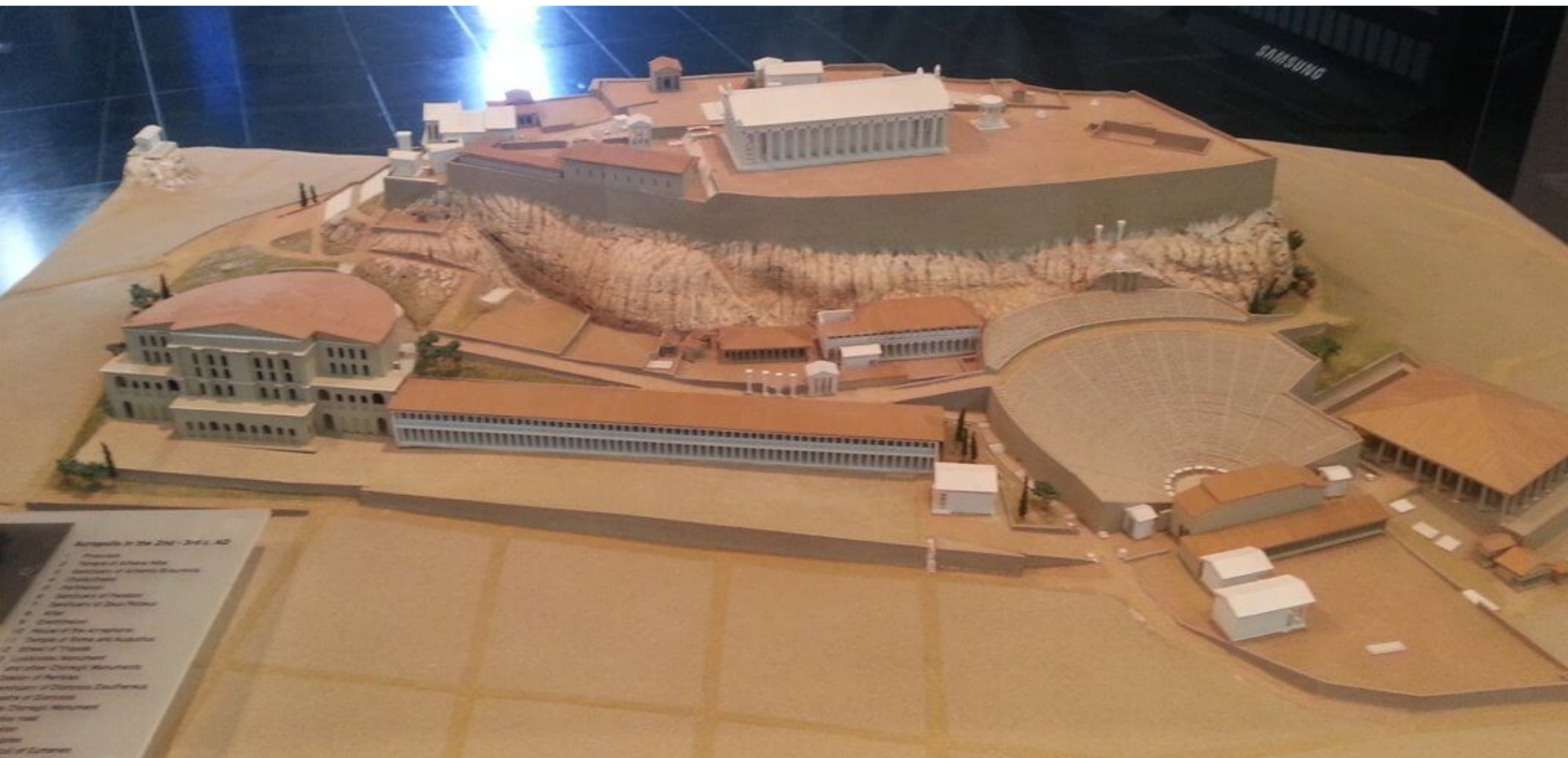

Dionýsovo divadlo po Lykurgově přestavbě, 4. stol. př. n. l.

Thorikos

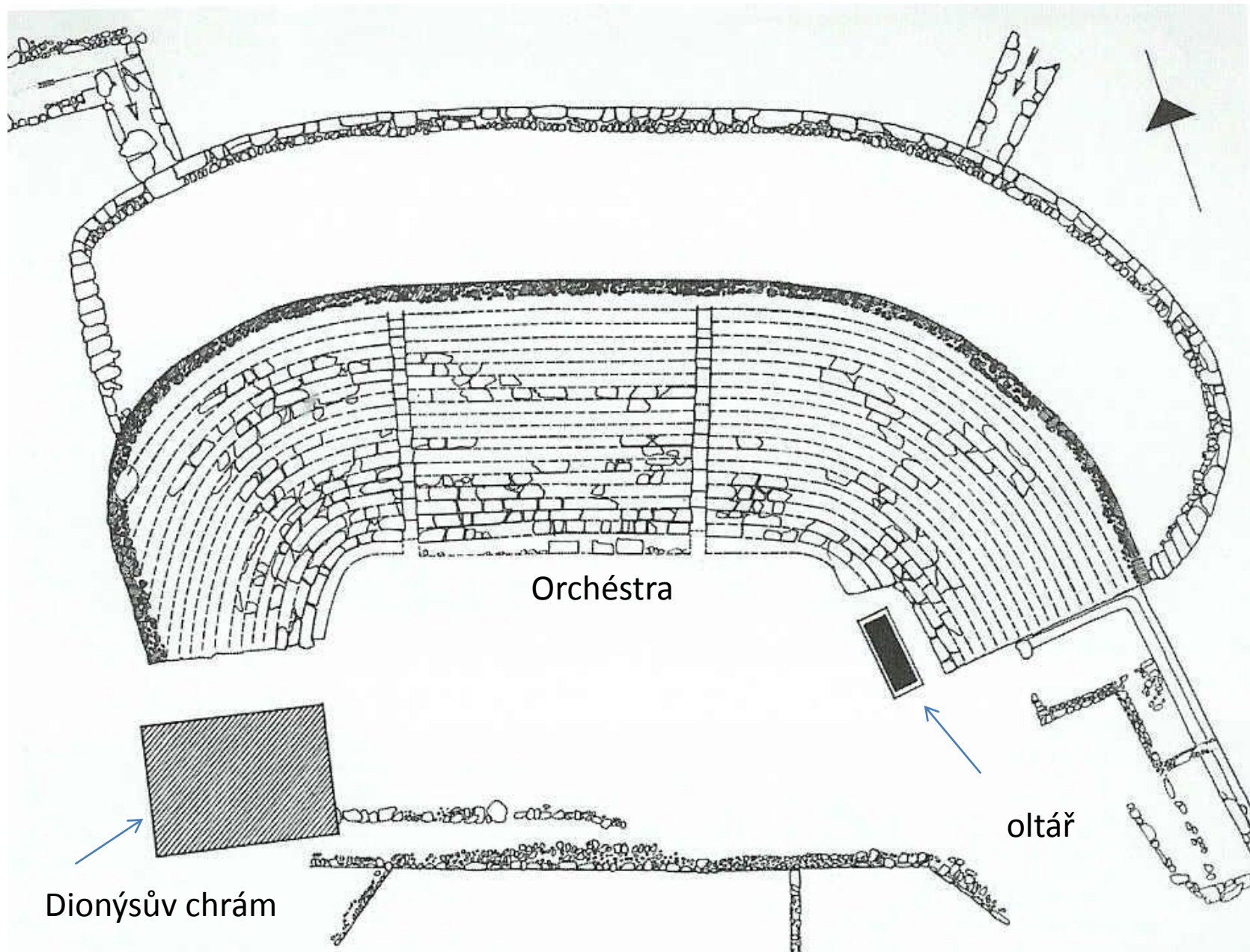

Thorikos – model

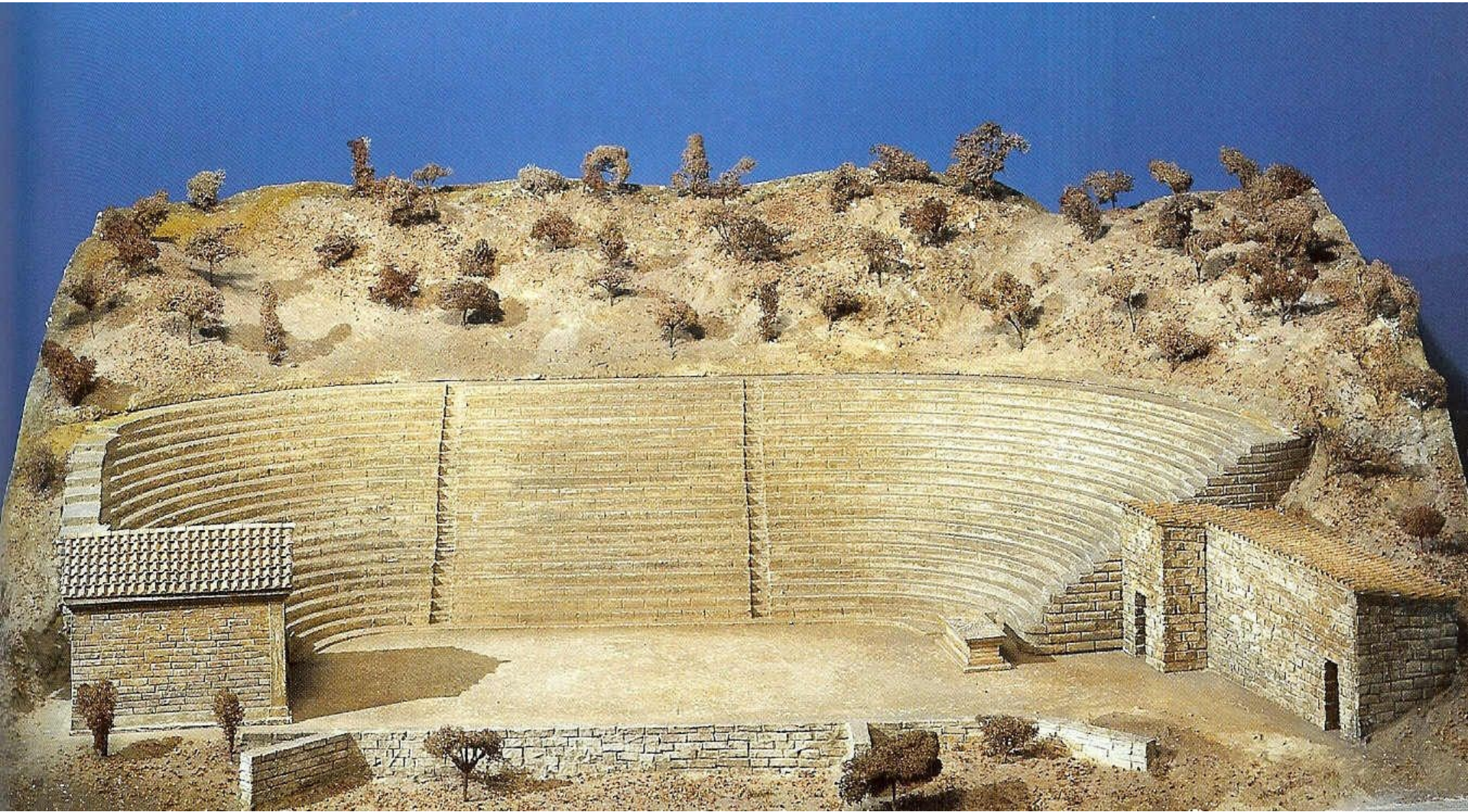

Thorikos – současná podoba









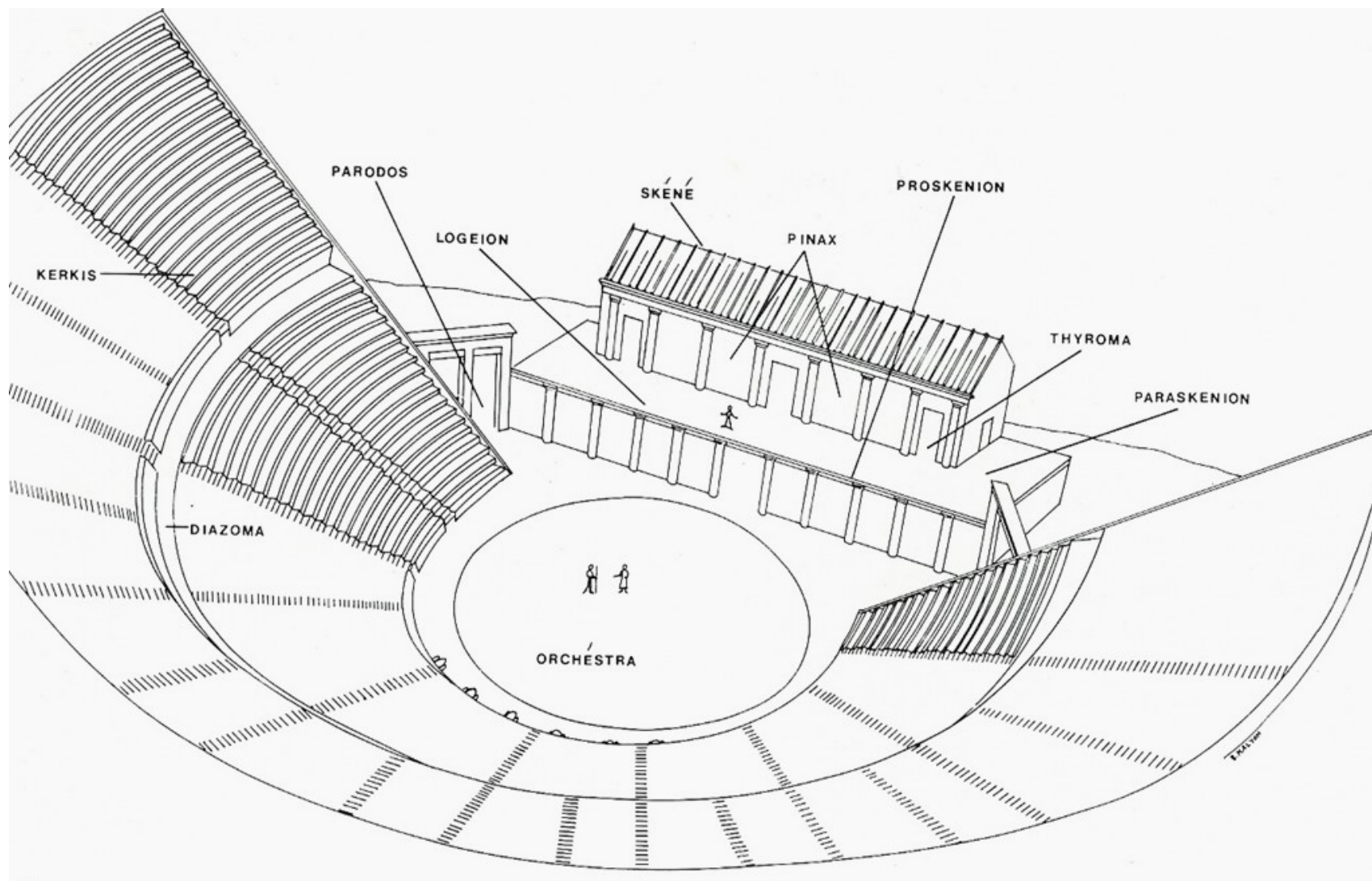

Orchestra



Epidauros

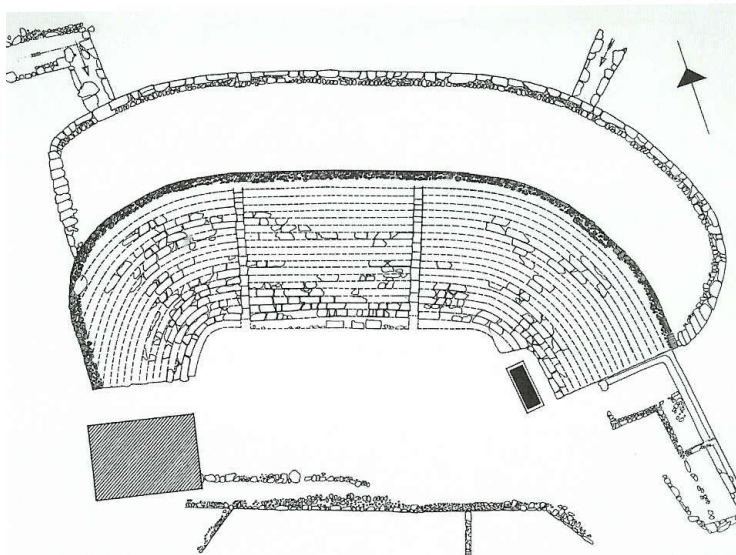

Thorikos

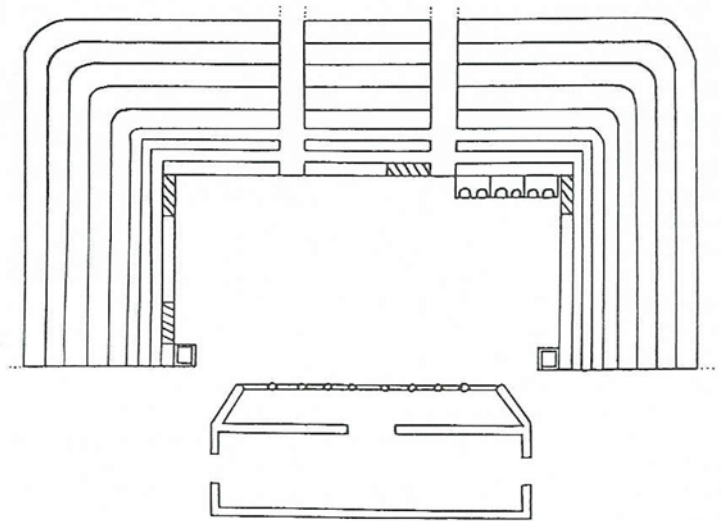

Euonymos

Skene

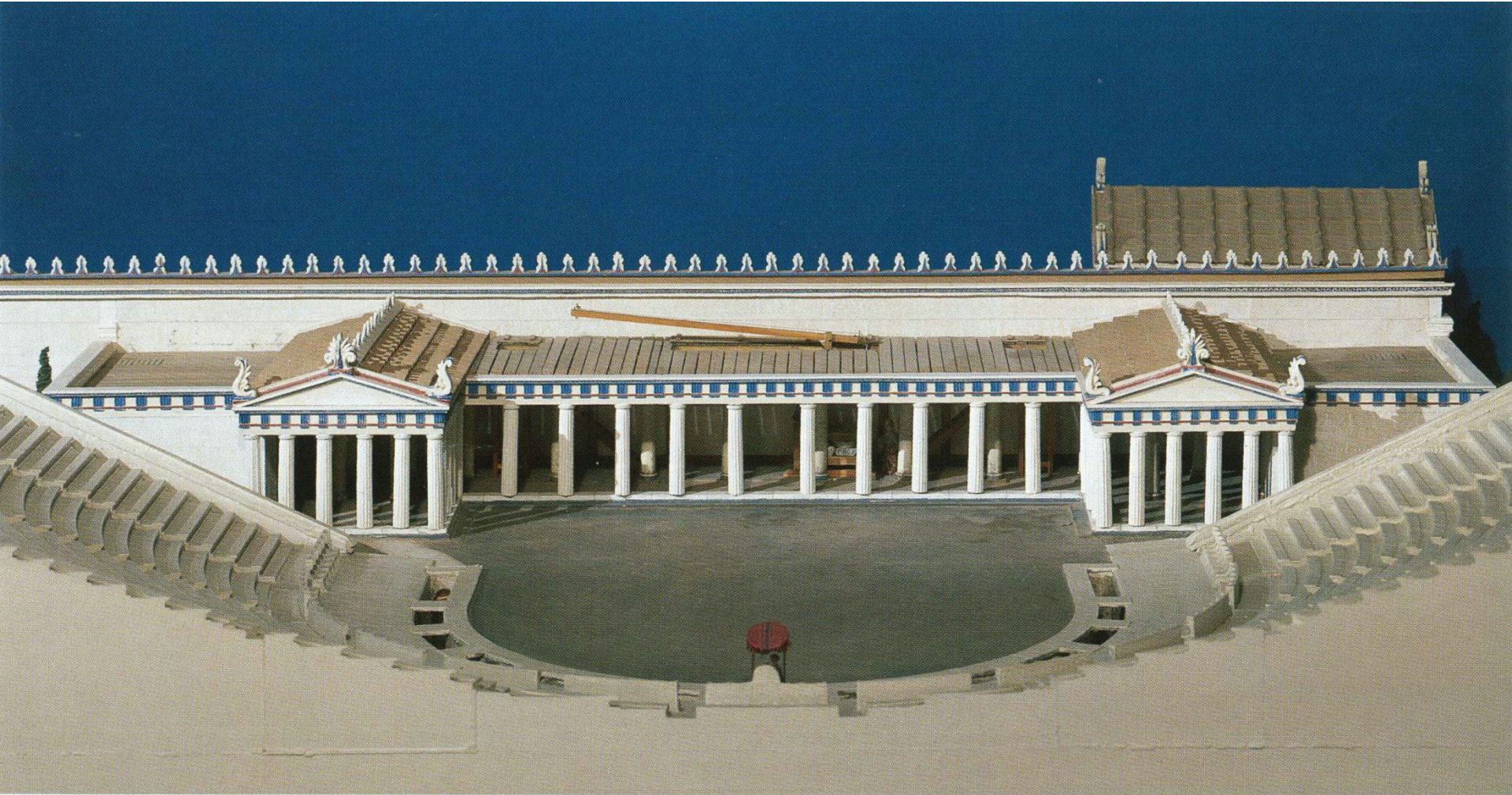

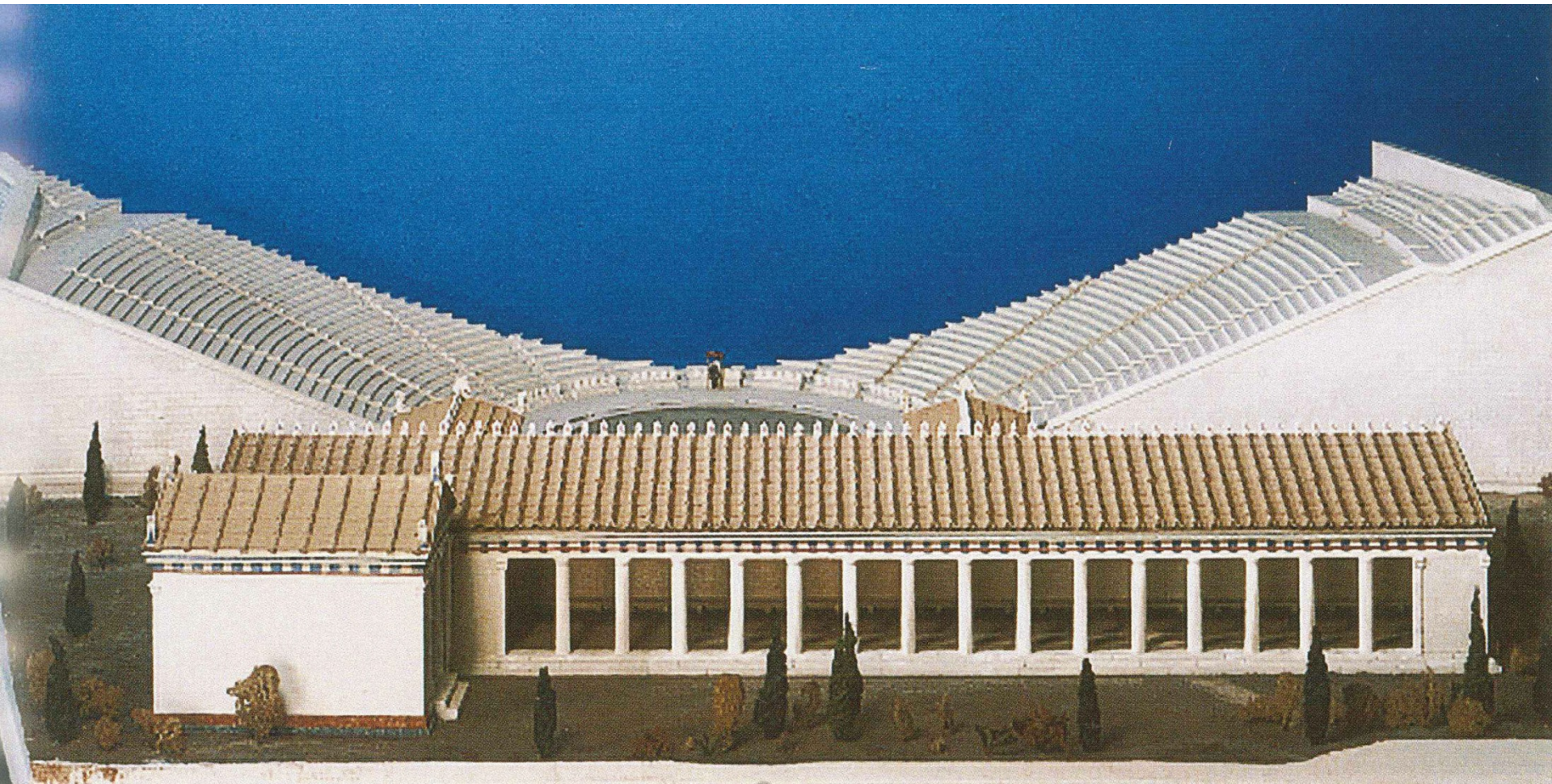

Proskénion – Paraskenia

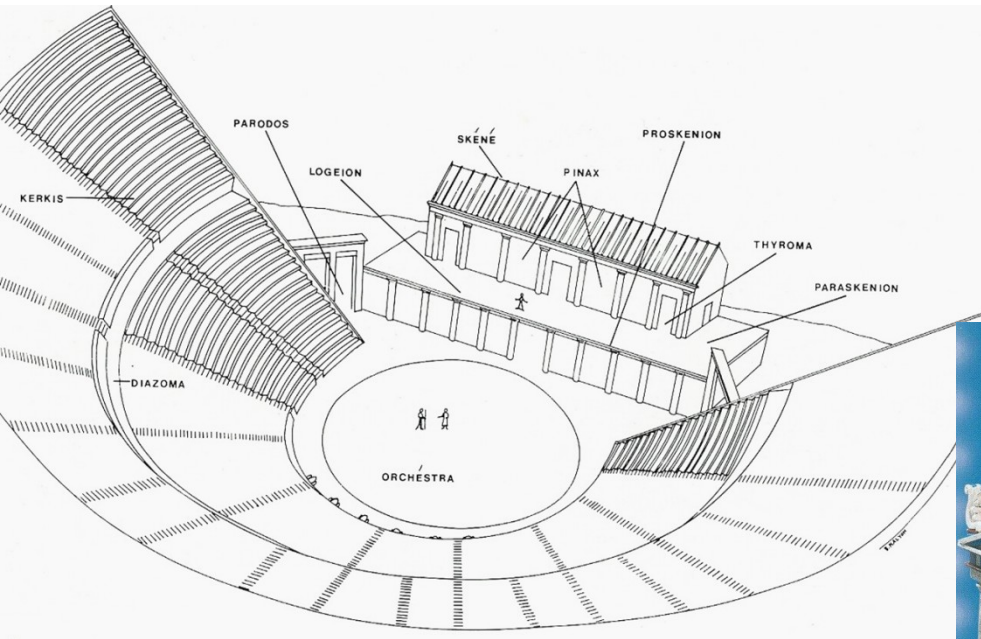

Logeion

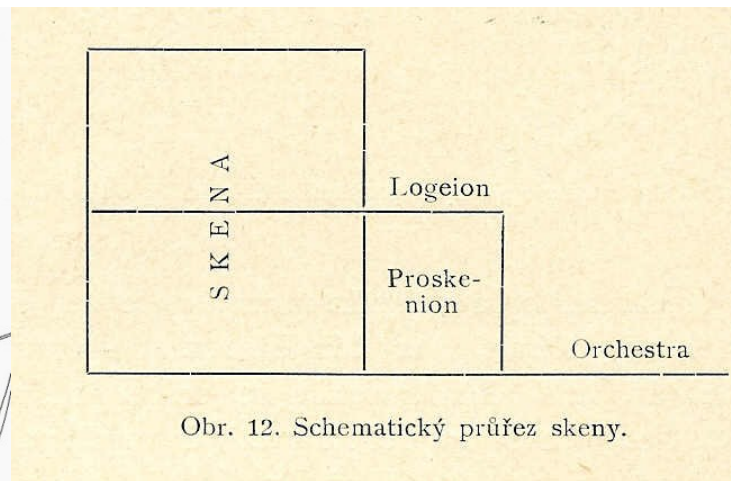
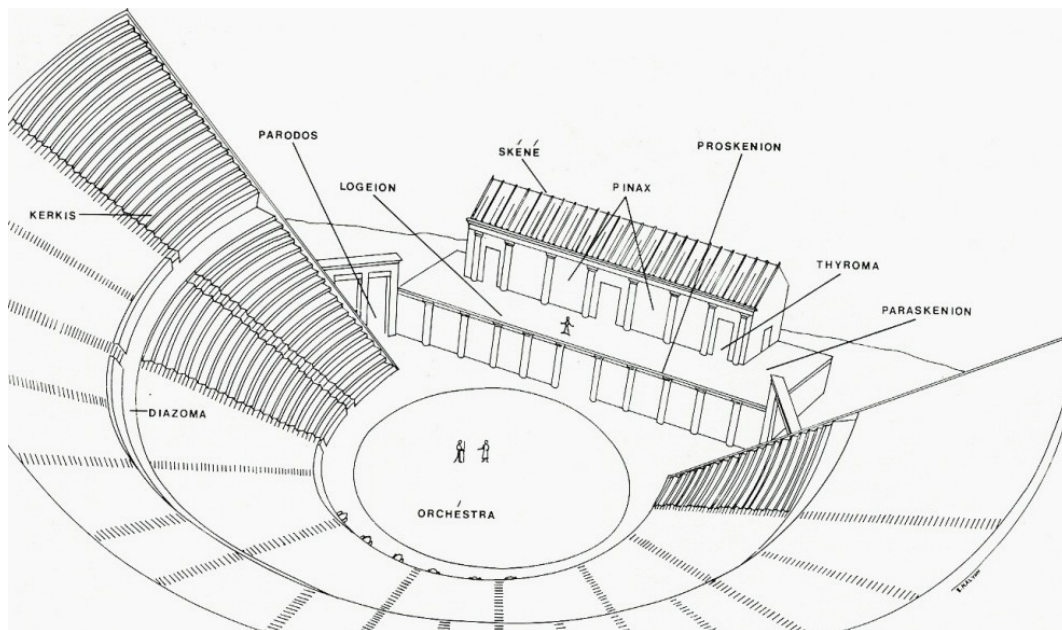

Obr. 12. Schematický průřez skeny.

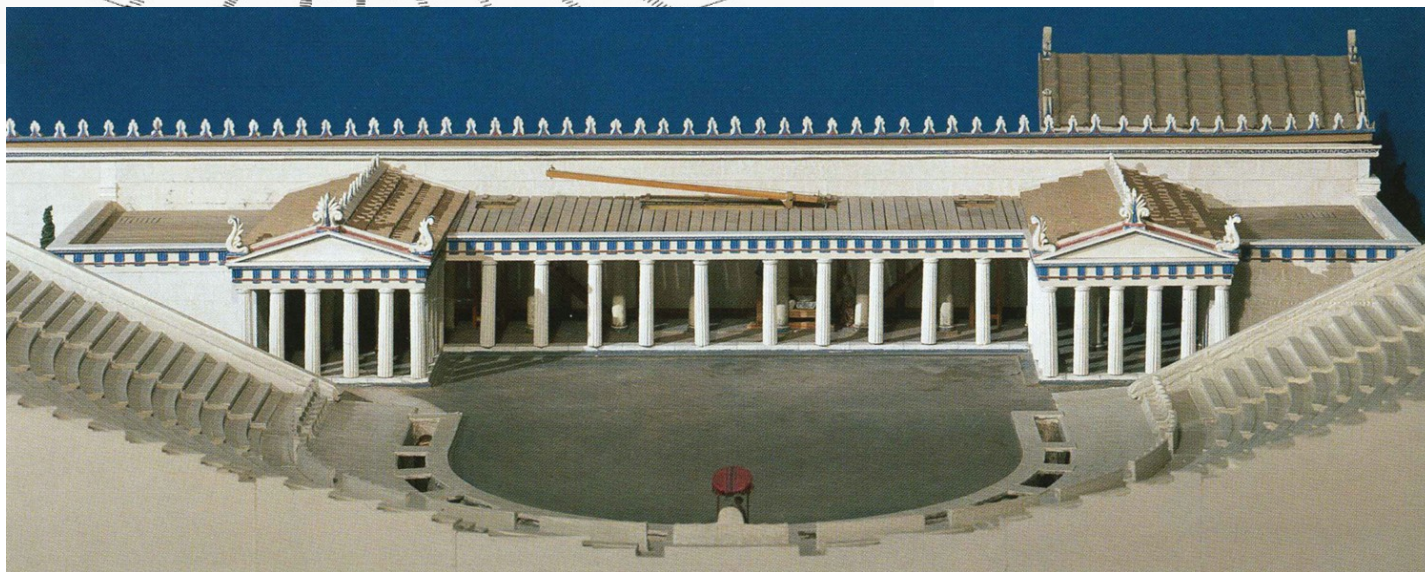

Eisodos



Roman Odeion at Ephesus: Parados Detail



Hellenistic Theatre at Priene: Pa

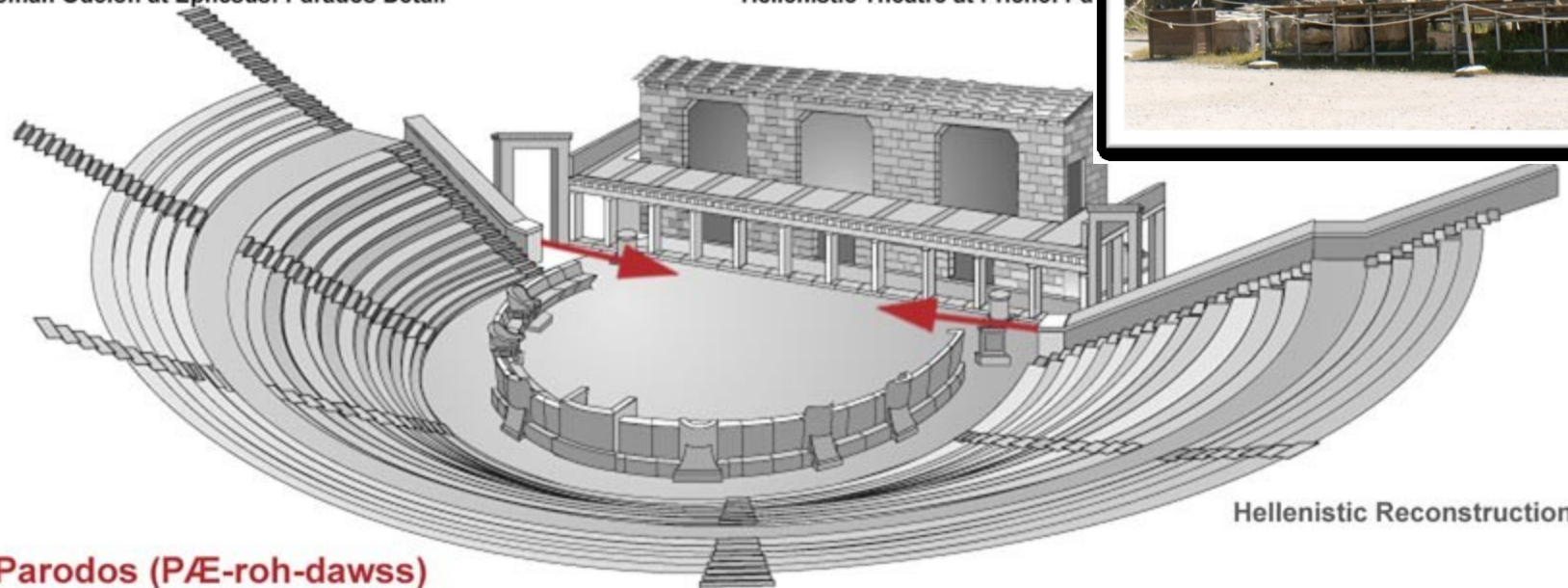
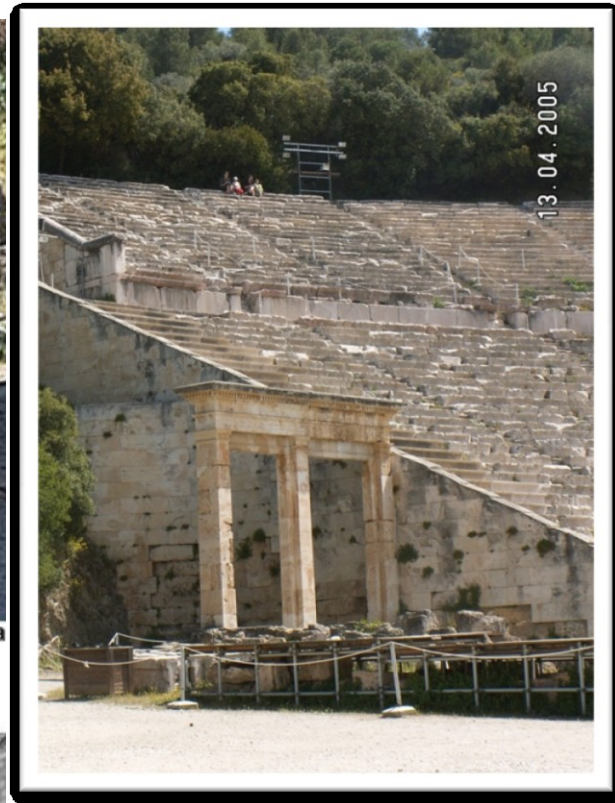

Hellenistic Reconstruction

Parodos (PÆ-roh-dawss)

(Greek; A passageway ;pl. paradoi) Side entrance into the orchestra of a Greek theater (one on each side); the space between the audience seating and the skene building; primary entrance/exit for the chorus and used by audience for entrance and exit from theatre; also the song sung by chorus as it first enters the orchestra.

Thymele

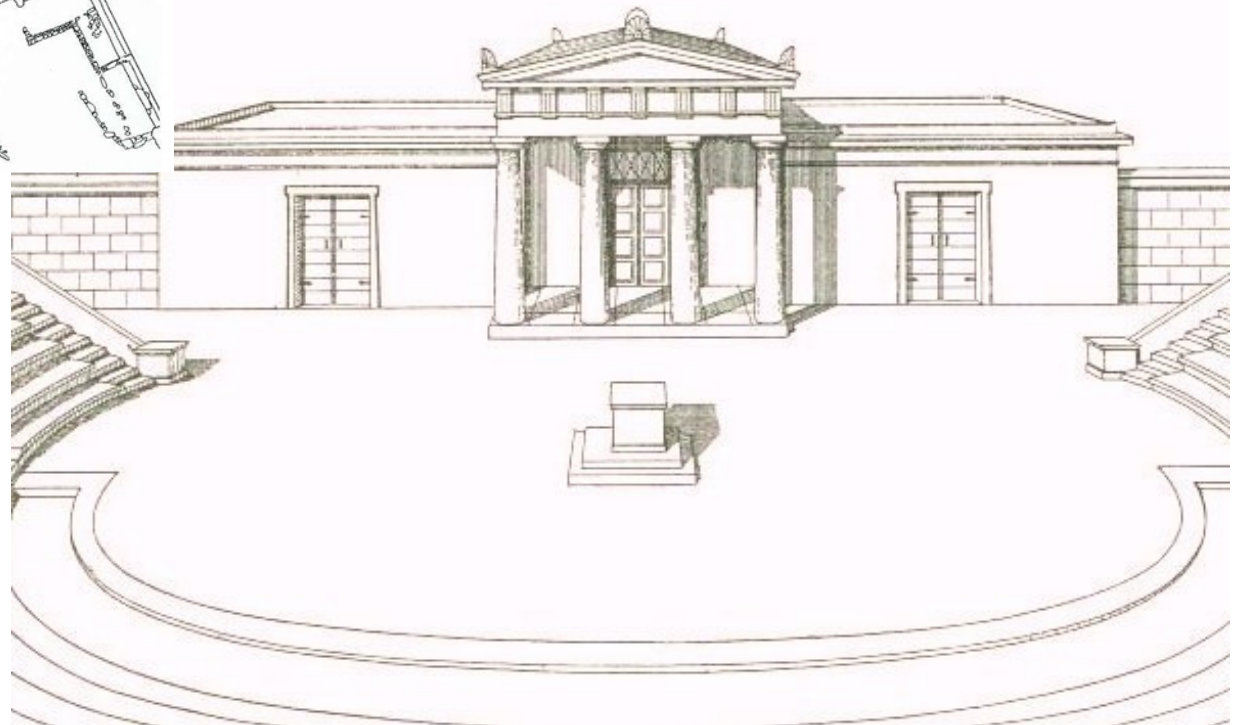
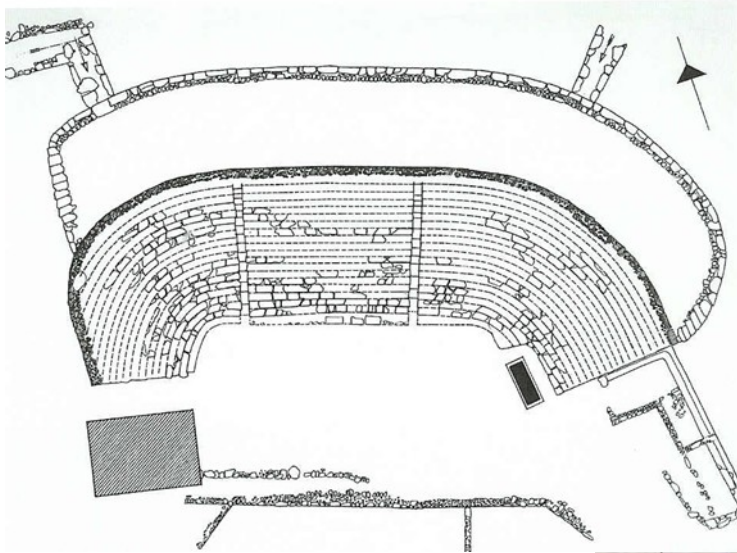

Enkyklema

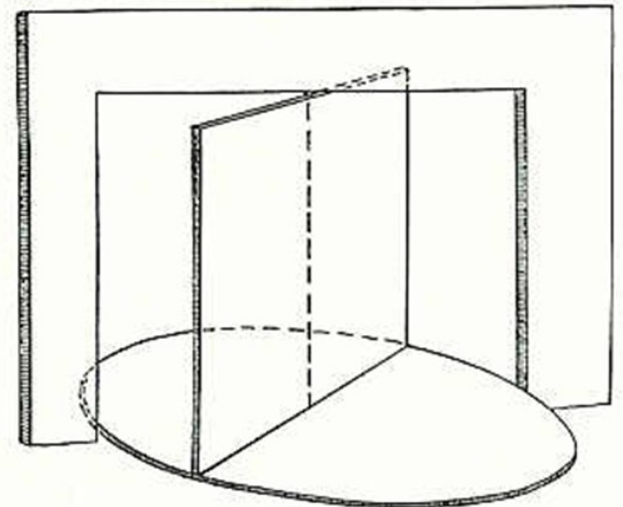
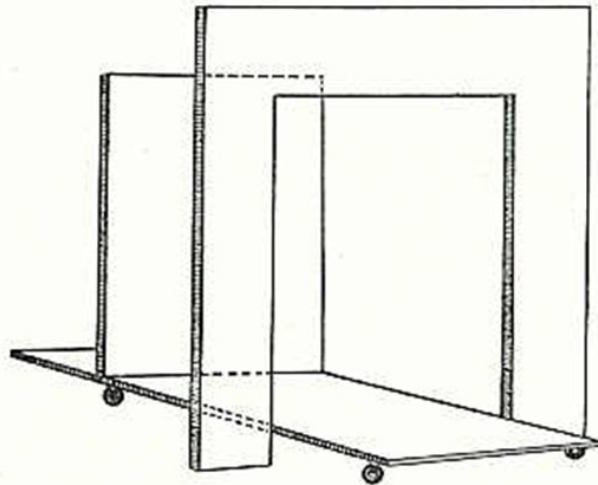

Mechane

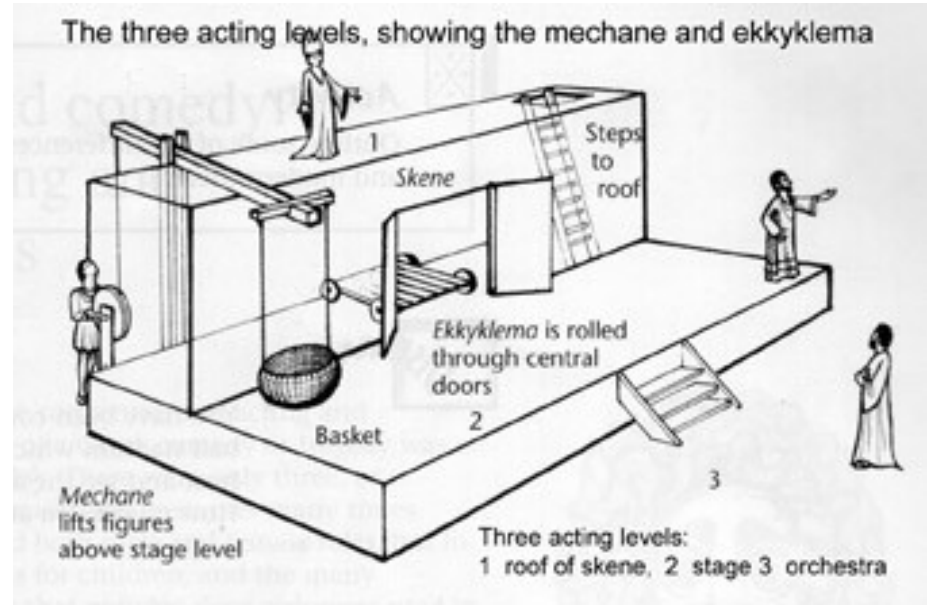
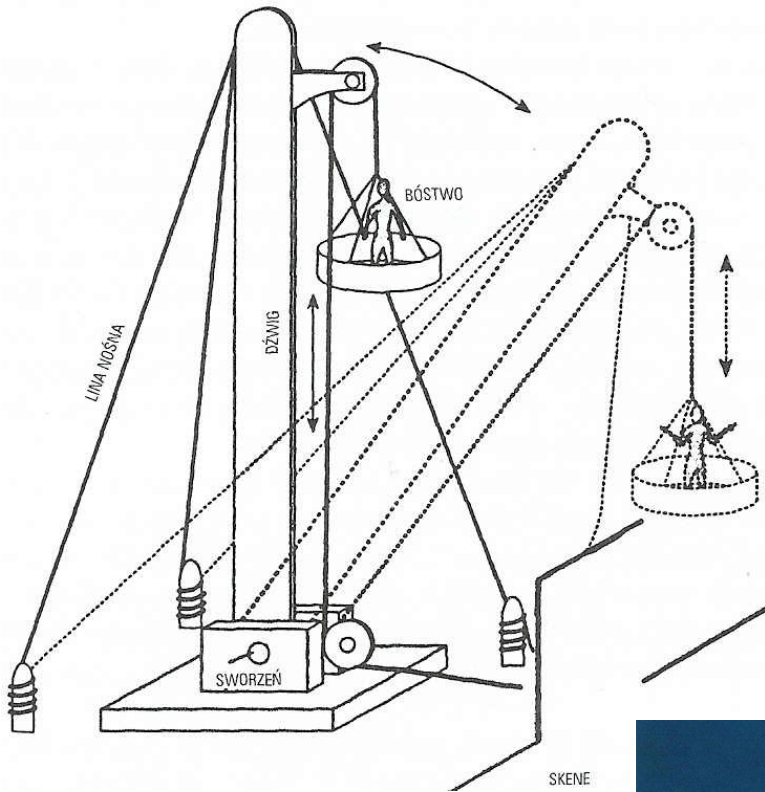



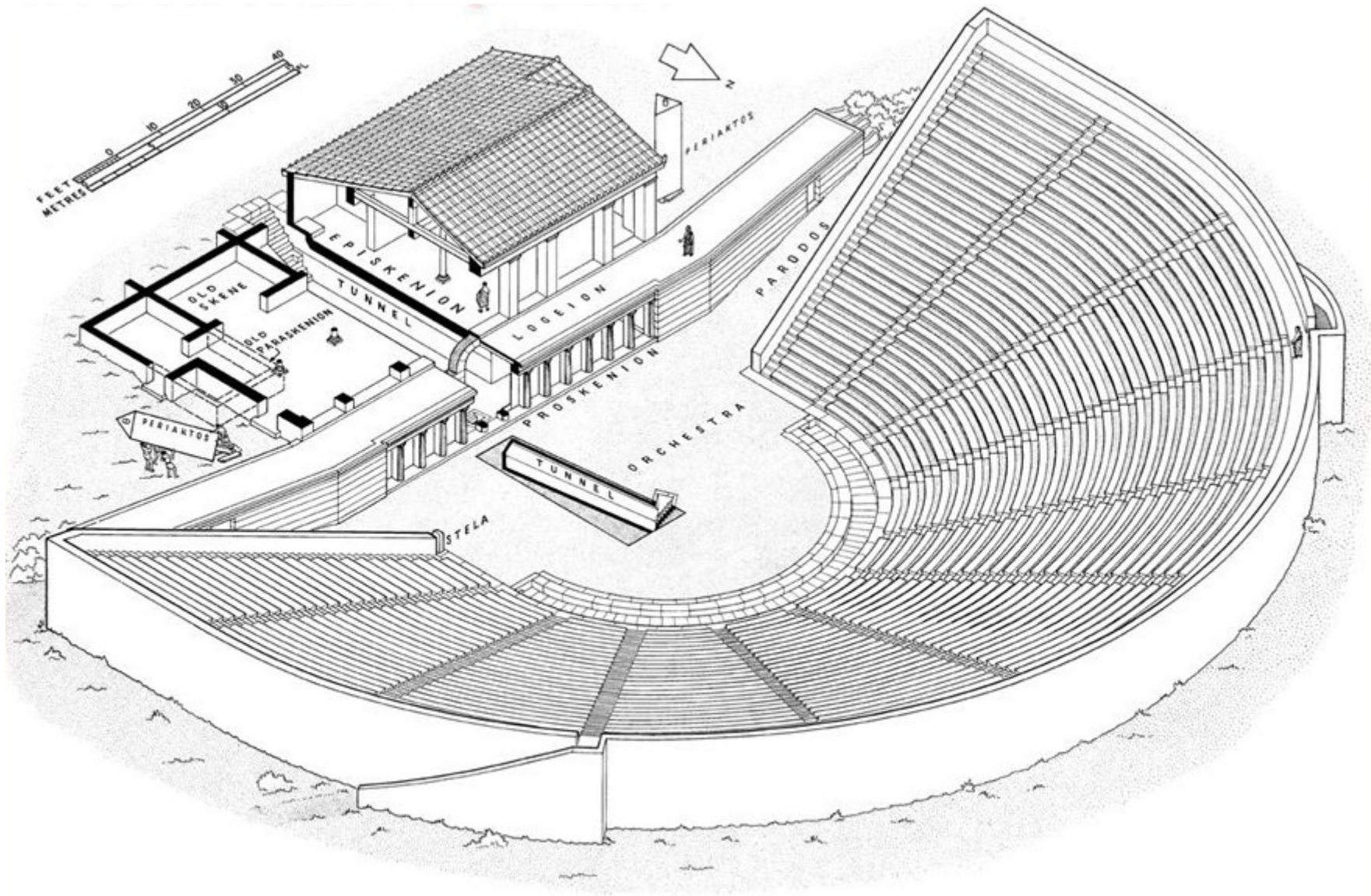

Eretria, Greece. The Hellenistic theatre

Periactoi/periacti

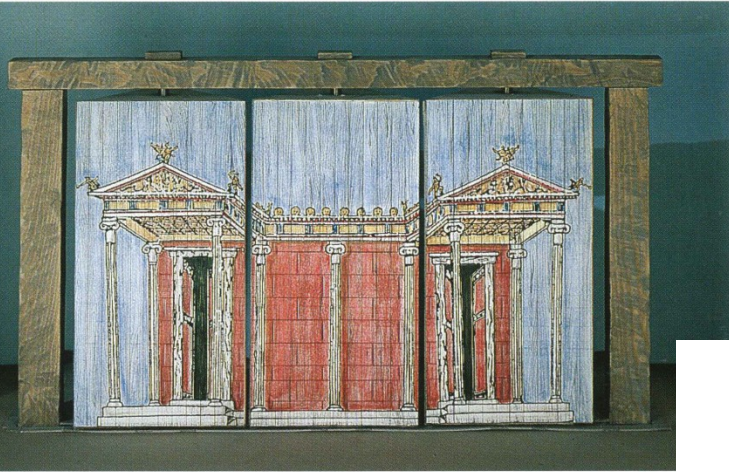

Pinakes

Pinakes (PIN-a-keez)
(Greek) Painted panels; temporary scenic elements usually placed in the openings (thyromata) of the Greek skene.

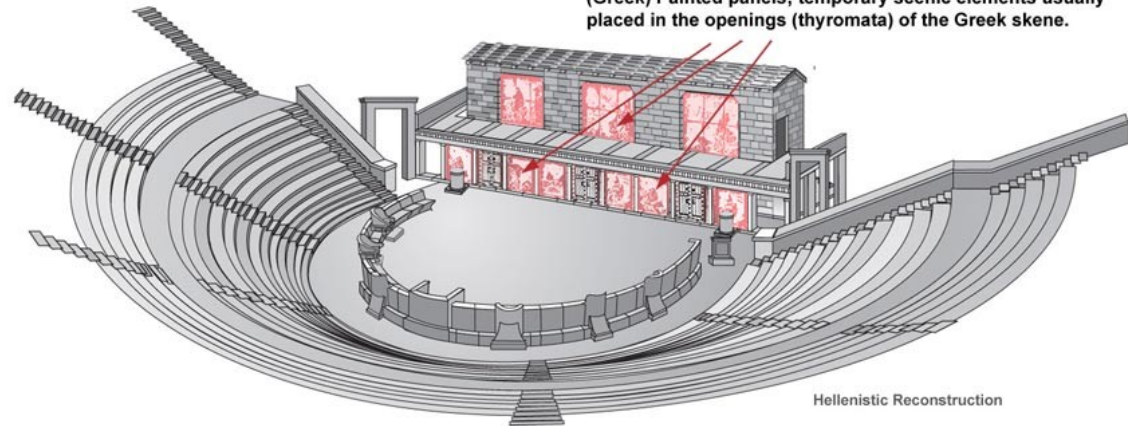



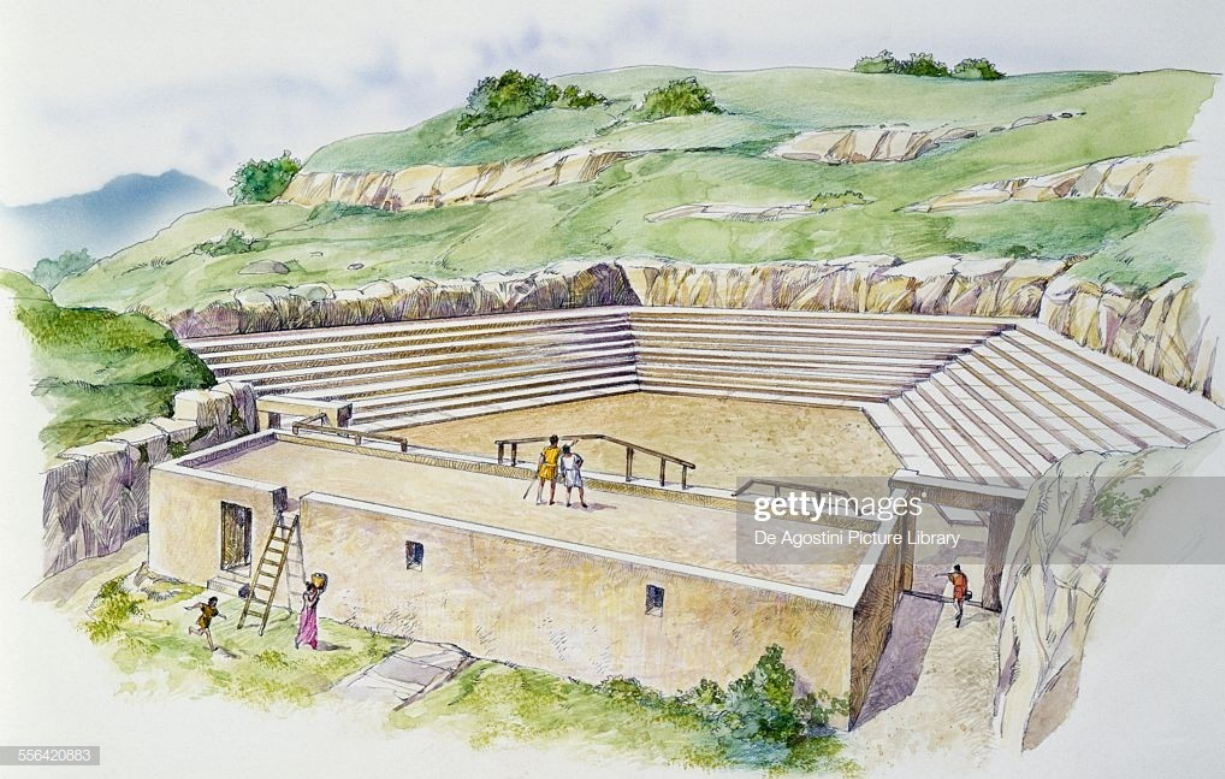

556420883

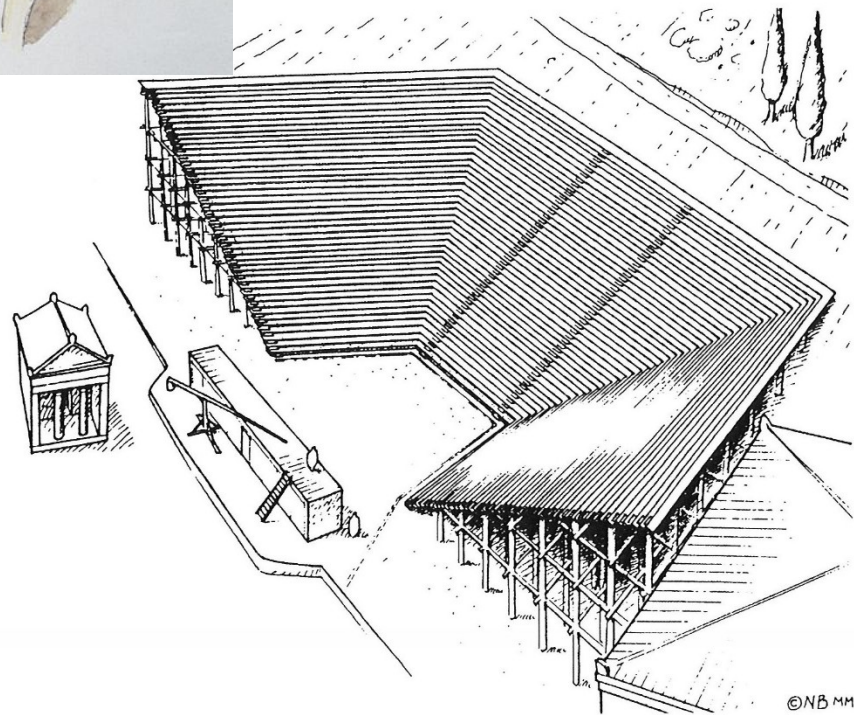

©NBMM

