

Jar 2006

F2050 Elektřina a magnetismus

Podmienky absolvovania cvičenia:

- **6 správne vyriešených domácich úloh**
- **min 2 body zo 4 bodovej písomky**

Kontakt:

Jozef Ráhel, tel. 54949 6747

rahel@mail.muni.cz

Štúdijné materiály:

<http://www.physics.muni.cz/~otobrzo/>

<http://www.sci.muni.cz/~trunec/elmag/elektrina.html>

Skalárne pole

„Číslo“ rozložené v priestore, napr. lokálna teplota, lokálna hustota náboja, lokálna merná hmotnosť (hustota)

$$u = u(x_1, x_2, x_3) = u(\vec{r})$$

Vektorové pole

„Šípky“ (vektory) rozložené v priestore, pričom každá „šípka“ má vlastný smer aj veľkosť.
Príklady: Intenzita elektrického alebo magnetického poľa, rýchlosti v prúdiacej kvapaline...

$$\vec{a} = \vec{a}(\vec{r}) = (a_1(\vec{r}), a_2(\vec{r}), a_3(\vec{r})) = a_1(\vec{r})\vec{e}_1 + a_2(\vec{r})\vec{e}_2 + a_3(\vec{r})\vec{e}_3$$

Príklad jenorozmerného vektorového poľa:

$$\vec{a} = \vec{a}(t) = (a_1(t), a_2(t), a_3(t)) = a_1(t)\vec{e}_1 + a_2(t)\vec{e}_2 + a_3(t)\vec{e}_3$$

Sčítanie a odčítanie vektorov

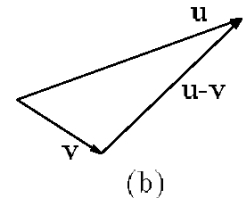
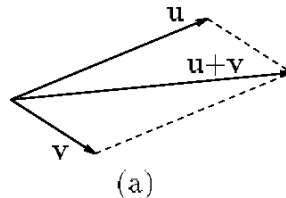

Skalárny súčin dvoch vektorov:

$$\vec{a} \cdot \vec{b} = a_1b_1 + a_2b_2 + a_3b_3 = \text{skalár (číslo)}$$

Vektorový súčin dvoch vektorov

$$\vec{a} \times \vec{b} = \det \begin{vmatrix} \vec{e}_1 & \vec{e}_2 & \vec{e}_3 \\ a_1 & a_2 & a_3 \\ b_1 & b_2 & b_3 \end{vmatrix} = (a_2b_3 - a_3b_2)\vec{e}_1 + (a_1b_3 - a_3b_1)\vec{e}_2 + (a_1b_2 - a_2b_1)\vec{e}_3 = \text{vektor}$$

Derivovanie vektorových funkcií

$$\frac{d}{dt} (\vec{a} \pm \vec{b} \pm \vec{c}) = \frac{d\vec{a}}{dt} \pm \frac{d\vec{b}}{dt} \pm \frac{d\vec{c}}{dt}$$

$$\frac{d}{dt} (\varphi \vec{a}) = \frac{d\varphi}{dt} \vec{a} + \varphi \frac{d\vec{a}}{dt} \quad (\varphi - \text{skalárna funkcia } t)$$

$$\frac{d}{dt} (\vec{a} \vec{b}) = \frac{d\vec{a}}{dt} \vec{b} + \vec{a} \frac{d\vec{b}}{dt}$$

$$\frac{d}{dt} (\vec{a} \times \vec{b}) = \frac{d\vec{a}}{dt} \times \vec{b} + \vec{a} \times \frac{d\vec{b}}{dt}$$

$$\frac{d}{dt} \vec{a}[\varphi(t)] = \frac{d\vec{a}}{d\varphi} \cdot \frac{d\varphi}{dt} \quad (\text{reťazové pravidlo})$$

Taylorov rozvoj vektorových funkcií:
$$\vec{a}(t+h) = \vec{a}(t) + h \frac{d\vec{a}}{dt} + \frac{h^2}{2} \frac{d^2\vec{a}}{dt^2} + \dots + \frac{h^n}{n!} \frac{d^n\vec{a}}{dt^n}$$

Súradnicové sústavy (najpoužívanejšie)

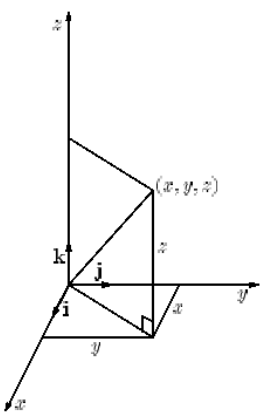
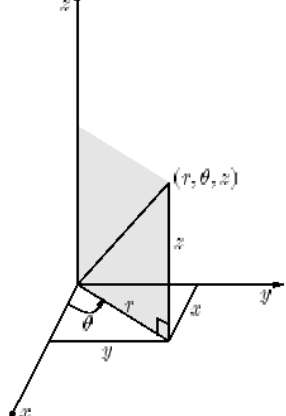
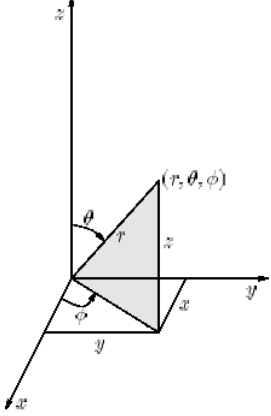
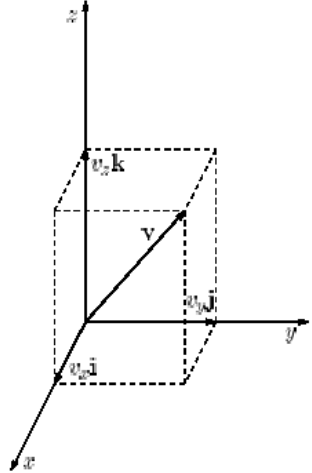
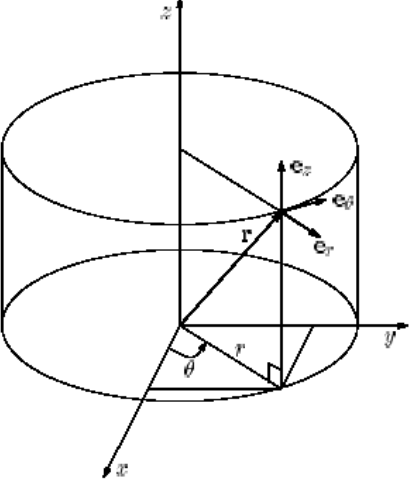
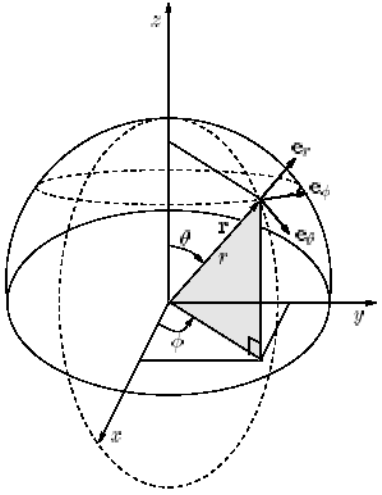
	Kartéziánska (pravouhlá) (x, y, z)	Cylindrická (r, θ, z)	Sférická (r, ϕ, θ)
súradnica			
Smer jednotkových vektorov			

Prevody cylindrická-kartéziánska

$(r, \theta, z) \rightarrow (x, y, z)$	$(x, y, z) \rightarrow (r, \theta, z)$
<u>Coordinates</u> $x = r \cos \theta$ $y = r \sin \theta$ $z = z$	$r = \sqrt{x^2 + y^2}$ $\theta = \begin{cases} \arctan \frac{y}{x}, & x > 0, y \geq 0 \\ \pi + \arctan \frac{y}{x}, & x < 0 \\ 2\pi + \arctan \frac{y}{x}, & x > 0, y < 0 \end{cases}$ $z = z$
<u>Unit vectors</u> $\mathbf{i} = \cos \theta \mathbf{e}_r - \sin \theta \mathbf{e}_\theta$ $\mathbf{j} = \sin \theta \mathbf{e}_r + \cos \theta \mathbf{e}_\theta$ $\mathbf{k} = \mathbf{e}_z$	$\mathbf{e}_r = \cos \theta \mathbf{i} + \sin \theta \mathbf{j}$ $\mathbf{e}_\theta = -\sin \theta \mathbf{i} + \cos \theta \mathbf{j}$ $\mathbf{e}_z = \mathbf{k}$

Prevody sférická -kartéziánska

$(r, \theta, \phi) \rightarrow (x, y, z)$	$(x, y, z) \rightarrow (r, \theta, \phi)$
<u>Coordinates</u> $x = r \sin \theta \cos \phi$ $y = r \sin \theta \sin \phi$ $z = r \cos \theta$	$r = \sqrt{x^2 + y^2 + z^2}$ $\theta = \begin{cases} \arctan \frac{\sqrt{x^2 + y^2}}{z}, & z > 0 \\ \frac{\pi}{2}, & z = 0 \\ \pi + \arctan \frac{\sqrt{x^2 + y^2}}{z}, & z < 0 \end{cases}$ $\phi = \begin{cases} \arctan \frac{y}{x}, & x > 0, y \geq 0 \\ \pi + \arctan \frac{y}{x}, & x < 0 \\ 2\pi + \arctan \frac{y}{x}, & x > 0, y < 0 \end{cases}$
<u>Unit vectors</u> $\mathbf{i} = \sin \theta \cos \phi \mathbf{e}_r + \cos \theta \cos \phi \mathbf{e}_\theta - \sin \phi \mathbf{e}_\phi$ $\mathbf{j} = \sin \theta \sin \phi \mathbf{e}_r + \cos \theta \sin \phi \mathbf{e}_\theta + \cos \phi \mathbf{e}_\phi$ $\mathbf{k} = \cos \theta \mathbf{e}_r - \sin \theta \mathbf{e}_\theta$	$\mathbf{e}_r = \sin \theta \cos \phi \mathbf{i} + \sin \theta \sin \phi \mathbf{j} + \cos \theta \mathbf{k}$ $\mathbf{e}_\theta = \cos \theta \cos \phi \mathbf{i} + \cos \theta \sin \phi \mathbf{j} - \sin \theta \mathbf{k}$ $\mathbf{e}_\phi = -\sin \phi \mathbf{i} + \cos \phi \mathbf{j}$

Polohový vektor \vec{r}

V karteziánskej sústave :

$$\vec{r} = x\vec{e}_x + y\vec{e}_y + z\vec{e}_z$$

pričom pre veľkosť platí:

$$|\vec{r}| = \sqrt{x^2 + y^2 + z^2}$$

V cylindrickej sústave:

$$\vec{r} = r\vec{e}_r + z\vec{e}_z$$

pričom pre veľkosť platí:

$$|\vec{r}| = \sqrt{r^2 + z^2}$$

Vo sférickej sústave:

$$\vec{r} = r\vec{e}_r$$

pričom pre veľkosť platí:

$$|\vec{r}| = r$$

Prevodová tabuľka

Kartesische Koordinaten	Zylinderkoordinaten	Kugelkoordinaten
$\vec{V} = V_x\vec{e}_x + V_y\vec{e}_y + V_z\vec{e}_z$	$V_\rho\vec{e}_\rho + V_\varphi\vec{e}_\varphi + V_z\vec{e}_z$	$V_r\vec{e}_r + V_\vartheta\vec{e}_\vartheta + V_\varphi\vec{e}_\varphi$
V_x	$= V_\rho \cos \varphi - V_\varphi \sin \varphi$	$= V_r \sin \vartheta \cos \varphi + V_\vartheta \cos \vartheta \cos \varphi - V_\varphi \sin \varphi$
V_y	$= V_\rho \sin \varphi + V_\varphi \cos \varphi$	$= V_r \sin \vartheta \sin \varphi + V_\vartheta \cos \vartheta \sin \varphi + V_\varphi \cos \varphi$
V_z	$= V_z$	$= V_r \cos \vartheta - V_\vartheta \sin \vartheta$
$V_x \cos \varphi + V_y \sin \varphi$	$= V_\rho$	$= V_r \sin \vartheta + V_\vartheta \cos \vartheta$
$-V_x \sin \varphi + V_y \cos \varphi$	$= V_\varphi$	$= V_\varphi$
V_z	$= V_z$	$= V_r \cos \vartheta - V_\vartheta \sin \vartheta$
$V_x \sin \vartheta \cos \varphi + V_y \sin \vartheta \sin \varphi + V_z \cos \vartheta$	$= V_\rho \sin \vartheta + V_z \cos \vartheta$	$= V_r$
$V_x \cos \vartheta \cos \varphi + V_y \cos \vartheta \sin \varphi - V_z \sin \vartheta$	$= V_\rho \cos \vartheta - V_z \sin \vartheta$	$= V_\vartheta$
$-V_x \sin \varphi + V_y \cos \varphi$	$= V_\varphi$	$= V_\varphi$

Derivovanie polí v karteziánskych súradniciach

Hamiltonov (nabla) operátor $\vec{\nabla} = \frac{\partial}{\partial x}\vec{e}_x + \frac{\partial}{\partial y}\vec{e}_y + \frac{\partial}{\partial z}\vec{e}_z = \left(\frac{\partial}{\partial x}, \frac{\partial}{\partial y}, \frac{\partial}{\partial z} \right)$

GRADIENT

Skalárne pole:

$$\text{grad } f(\vec{r}) \equiv \vec{\nabla}f(x, y, z) = \left(\frac{\partial f}{\partial x}, \frac{\partial f}{\partial y}, \frac{\partial f}{\partial z} \right)$$

Vyrobí zo skalárneho poľa $f(\mathbf{r})$ vektorové pole. Udáva smer a veľkosť najväčšej zmeny v skalárnom poli.

Vektorové pole:

$$\text{grad } \vec{V}(\vec{r}) \equiv \vec{\nabla} \vec{V}(x, y, z) = \begin{pmatrix} \frac{\partial V_x}{\partial x} & \frac{\partial V_x}{\partial y} & \frac{\partial V_x}{\partial z} \\ \frac{\partial V_y}{\partial x} & \frac{\partial V_y}{\partial y} & \frac{\partial V_y}{\partial z} \\ \frac{\partial V_z}{\partial x} & \frac{\partial V_z}{\partial y} & \frac{\partial V_z}{\partial z} \end{pmatrix}$$

DIVERGENCIA

$$\text{div } \vec{F} \equiv \vec{\nabla} \cdot \vec{F} = \frac{\partial F_x}{\partial x} + \frac{\partial F_y}{\partial y} + \frac{\partial F_z}{\partial z}$$

Udáva „žriedlovosť“ vektorového poľa.

ROTÁCIA

$$\text{rot } \vec{F} \equiv \vec{\nabla} \times \vec{F} = \begin{vmatrix} \vec{e}_x & \vec{e}_y & \vec{e}_z \\ \frac{\partial}{\partial x} & \frac{\partial}{\partial y} & \frac{\partial}{\partial z} \\ F_x & F_y & F_z \end{vmatrix} = \left(\frac{\partial F_z}{\partial y} - \frac{\partial F_y}{\partial z}, \frac{\partial F_x}{\partial z} - \frac{\partial F_z}{\partial x}, \frac{\partial F_y}{\partial x} - \frac{\partial F_x}{\partial y} \right)$$

Udáva „vírovosť“ vektorového poľa.

LAPLACIÁN

$$\Delta = \nabla \cdot \nabla = \nabla^2$$

$$\Delta U(x, y, z) = \frac{\partial^2 U}{\partial x^2} + \frac{\partial^2 U}{\partial y^2} + \frac{\partial^2 U}{\partial z^2}$$

Operátor nabra v rôznych súradnicových systémoch

Karteziánske $\vec{\nabla} = \vec{e}_x \frac{\partial}{\partial x} + \vec{e}_y \frac{\partial}{\partial y} + \vec{e}_z \frac{\partial}{\partial z} = \left(\frac{\partial}{\partial x}, \frac{\partial}{\partial y}, \frac{\partial}{\partial z} \right)$

Cylindrické $\vec{\nabla} = \vec{e}_r \frac{\partial}{\partial r} + \vec{e}_\theta \frac{1}{r} \frac{\partial}{\partial \theta} + \vec{e}_z \frac{\partial}{\partial z}$

Sférické $\vec{\nabla} = \vec{e}_r \frac{\partial}{\partial r} + \vec{e}_\theta \frac{1}{r} \frac{\partial}{\partial \theta} + \vec{e}_\phi \frac{1}{r \sin \theta} \frac{\partial}{\partial \phi}$

Diferenciálne vektorové operátory v karteziánskych, cylindrických a sférických súradniciach

	Kartesische Koordinaten	Zylinderkoordinaten	Kugelkoordinaten
$d\vec{s} = d\vec{r}$	$\vec{e}_x dx + \vec{e}_y dy + \vec{e}_z dz$	$\vec{e}_\rho d\rho + \vec{e}_\varphi \rho d\varphi + \vec{e}_z dz$	$\vec{e}_r dr + \vec{e}_\vartheta r d\vartheta + \vec{e}_\varphi r \sin \vartheta d\varphi$
gradU	$\vec{e}_x \frac{\partial U}{\partial x} + \vec{e}_y \frac{\partial U}{\partial y} + \vec{e}_z \frac{\partial U}{\partial z}$	$\vec{e}_\rho \frac{\partial U}{\partial \rho} + \vec{e}_\varphi \frac{1}{\rho} \frac{\partial U}{\partial \varphi} + \vec{e}_z \frac{\partial U}{\partial z}$	$\vec{e}_r \frac{\partial U}{\partial r} + \vec{e}_\vartheta \frac{1}{r} \frac{\partial U}{\partial \vartheta} + \vec{e}_\varphi \frac{1}{r \sin \vartheta} \frac{\partial U}{\partial \varphi}$
div \vec{V}	$\frac{\partial V_x}{\partial x} + \frac{\partial V_y}{\partial y} + \frac{\partial V_z}{\partial z}$	$\frac{1}{\rho} \frac{\partial}{\partial \rho}(\rho V_\rho) + \frac{1}{\rho} \frac{\partial V_\varphi}{\partial \varphi} + \frac{\partial V_z}{\partial z}$	$\frac{1}{r^2} \frac{\partial}{\partial r}(r^2 V_r) + \frac{1}{r \sin \vartheta} \frac{\partial}{\partial \vartheta}(V_\vartheta \sin \vartheta) + \frac{1}{r \sin \vartheta} \frac{\partial V_\varphi}{\partial \varphi}$
rot \vec{V}	$\vec{e}_x \left(\frac{\partial V_z}{\partial y} - \frac{\partial V_y}{\partial z} \right) + \vec{e}_y \left(\frac{\partial V_x}{\partial z} - \frac{\partial V_z}{\partial x} \right) + \vec{e}_z \left(\frac{\partial V_y}{\partial x} - \frac{\partial V_x}{\partial y} \right)$	$\vec{e}_\rho \left(\frac{1}{\rho} \frac{\partial V_z}{\partial \varphi} - \frac{\partial V_\varphi}{\partial z} \right) + \vec{e}_\varphi \left(\frac{\partial V_\rho}{\partial z} - \frac{\partial V_z}{\partial \rho} \right) + \vec{e}_z \left(\frac{1}{\rho} \frac{\partial}{\partial \rho}(\rho V_\varphi) - \frac{1}{\rho} \frac{\partial V_\rho}{\partial \varphi} \right)$	$\vec{e}_r \frac{1}{r \sin \vartheta} \left[\frac{\partial}{\partial \vartheta}(V_\varphi \sin \vartheta) - \frac{\partial V_\vartheta}{\partial \varphi} \right] + \vec{e}_\vartheta \frac{1}{r} \left[\frac{1}{\sin \vartheta} \frac{\partial V_r}{\partial \varphi} - \frac{\partial}{\partial r}(r V_\varphi) \right] + \vec{e}_\varphi \frac{1}{r} \left[\frac{\partial}{\partial r}(r V_\vartheta) - \frac{\partial V_r}{\partial \vartheta} \right]$
ΔU	$\frac{\partial^2 U}{\partial x^2} + \frac{\partial^2 U}{\partial y^2} + \frac{\partial^2 U}{\partial z^2}$	$\frac{1}{\rho} \frac{\partial}{\partial \rho} \left(\rho \frac{\partial U}{\partial \rho} \right) + \frac{1}{\rho^2} \frac{\partial^2 U}{\partial \varphi^2} + \frac{\partial^2 U}{\partial z^2}$	$\frac{1}{r^2} \frac{\partial}{\partial r} \left(r^2 \frac{\partial U}{\partial r} \right) + \frac{1}{r^2 \sin \vartheta} \frac{\partial}{\partial \vartheta} \left(\sin \vartheta \frac{\partial U}{\partial \vartheta} \right) + \frac{1}{r^2 \sin^2 \vartheta} \frac{\partial^2 U}{\partial \varphi^2}$

Príklady:

Úloha č. 1

Ukážte, že jednotkové vektory v cylindrickej súradnicovej sústave tvoria ortonormálny systém.

Úloha č. 2

Jednotkové vektory v karteziánskom súr. Systéme sa nemenia v závislosti od pozície. To ale neplatí pre krivočiare súradnicové systémy. Pre cylindrický súr. systém určite, čomu sa rovnajú derivácie jednotlivých jednotkových vektorov podľa každej z priestorových súradníc.

Úloha č. 3

Ukážte rozkladom na jednotlivé parciálne derivácie, že v karteziánskom súradnicovom systéme platí nasledujúca identita:

$$\operatorname{div}(f\vec{u}) = f \operatorname{div}(\vec{u}) + \vec{u} \cdot \operatorname{grad} f$$

pričom f označuje skalárne pole a \vec{u} vektorové pole.

Úloha č. 4

Vyjadrite nabla-operátor v cylindrických súradniciach. Pomocou nájdeneho tvaru operátora určte **grad** f a **div** \vec{u} .

Domáca úloha č.1

Zistite, či rovnaká identita ako v úlohe č.3 platí aj pre cylindrický súradnicový systém.
