

# Mechanical Properties

**Mechanical properties = response of a material to an applied load or force (deformation)**

**Two important regimes of mechanical behavior:**

**Elastic** (non-permanent) deformation - governed by the stretching of atomic bonds

**Plastic** (permanent) deformation - governed by the motion of dislocations

# **Mechanical Properties**

**Tensile Strength**

**Yield Strength**

**Stiffness, modulus of elasticity**

**Toughness**

**Ductility/Brittleness**

**Fracture Strength**

**Hardness**

# Stress and Strain

"Language" of Mechanical Properties: *Stress and Strain*

$$\text{Stress } \sigma = \frac{F}{A_0} \text{ [MPa]}$$

$F$  = load [N],  $A_0$  = cross sectional area [m<sup>2</sup>]

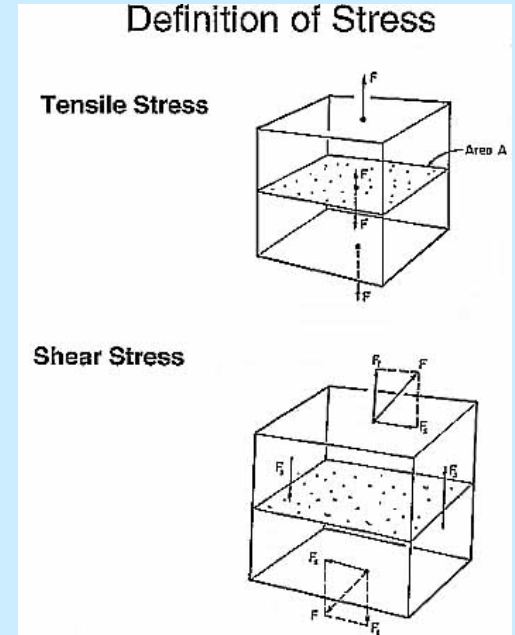

Stress

tensile  
compressive  
shear  
torsional  
bending

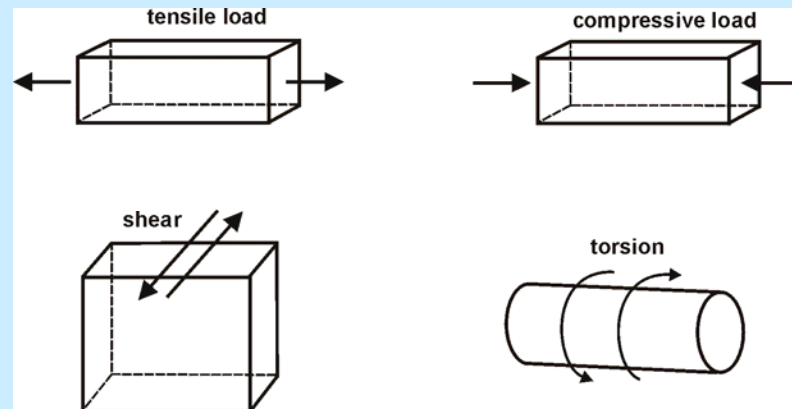

# Strain

**Strain (stretch) = relative elongation**

$$\varepsilon = \frac{\Delta l}{l_0} \quad [\text{m/m}]$$

$\Delta l$  = elongation

$l_0$  = original length

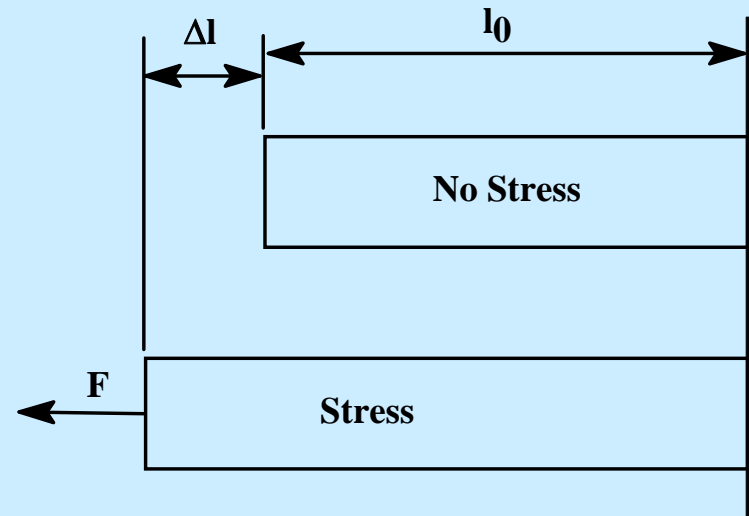

# Stress-Strain Diagram

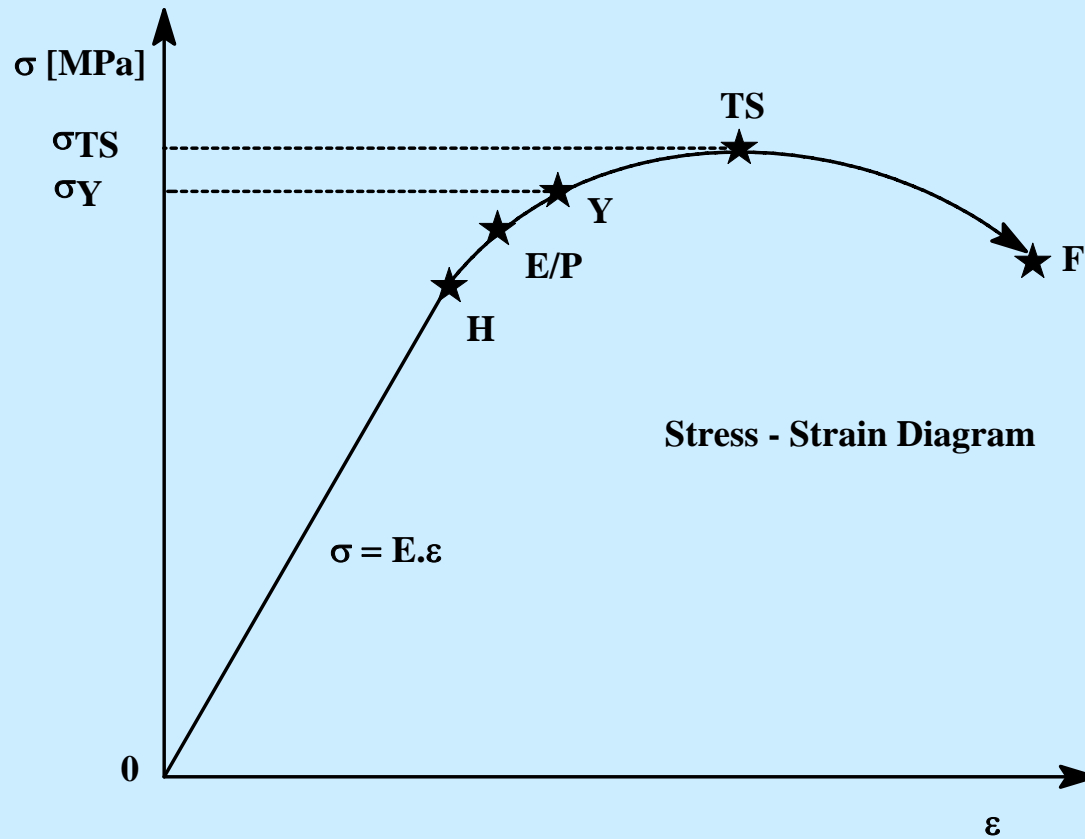

# Stress-Strain Diagram

## Stress – Strain Behavior

<b>0 – E/P</b>	<b>Elastic Deformation, recoverable</b>
<b>E/P – F</b>	<b>Plastic Deformation, irrecoverable</b>
<b>0 – H</b>	<b>Linear Region, Small Strain, Hooke's Law</b>
<b>H</b>	<b>Proportional Limit</b>
<b>Y</b>	<b>Yield Point, Engineering Yield Strength (at 0.2% strain)</b>
<b>TS</b>	<b>Tensile Strength = a maximum of the <math>\sigma</math>-<math>\epsilon</math> curve</b>
<b>F</b>	<b>Fracture, Break Point</b>

# Stress – Strain Behavior

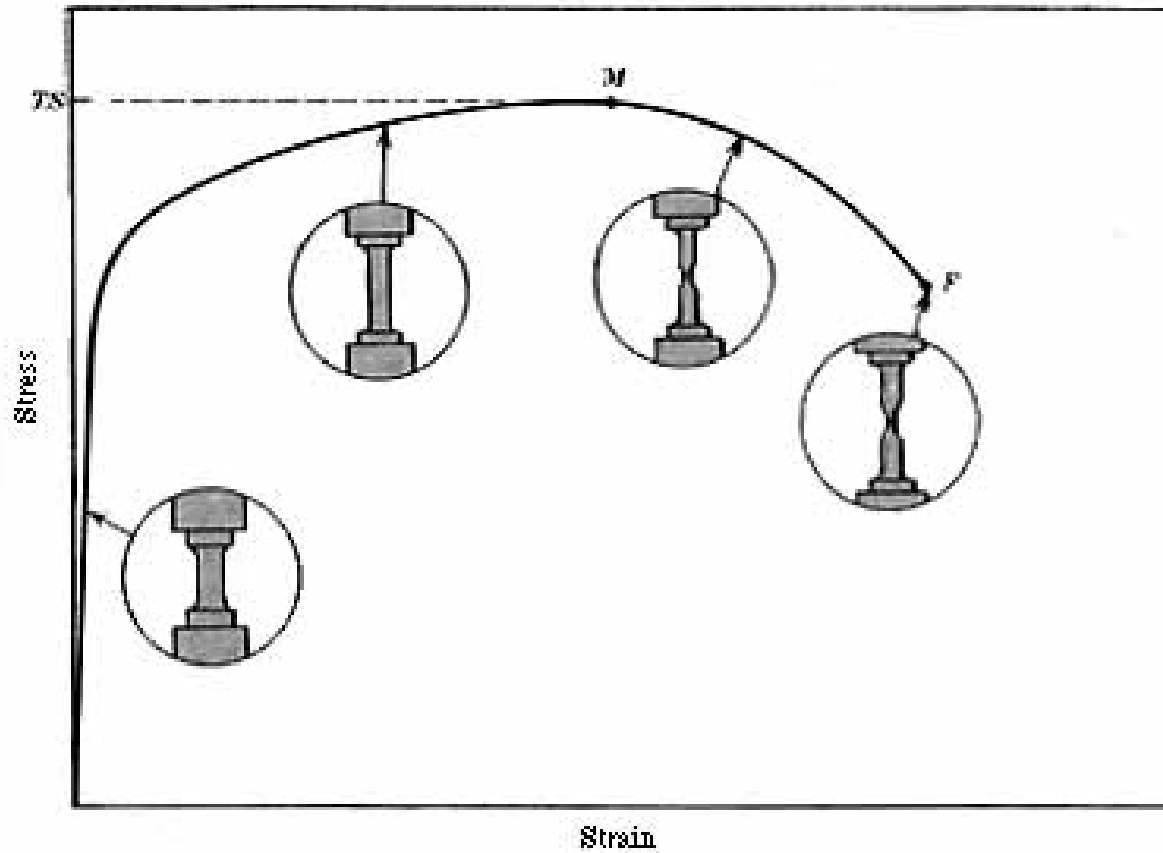

## Stress-Strain Curve for Ductile Material

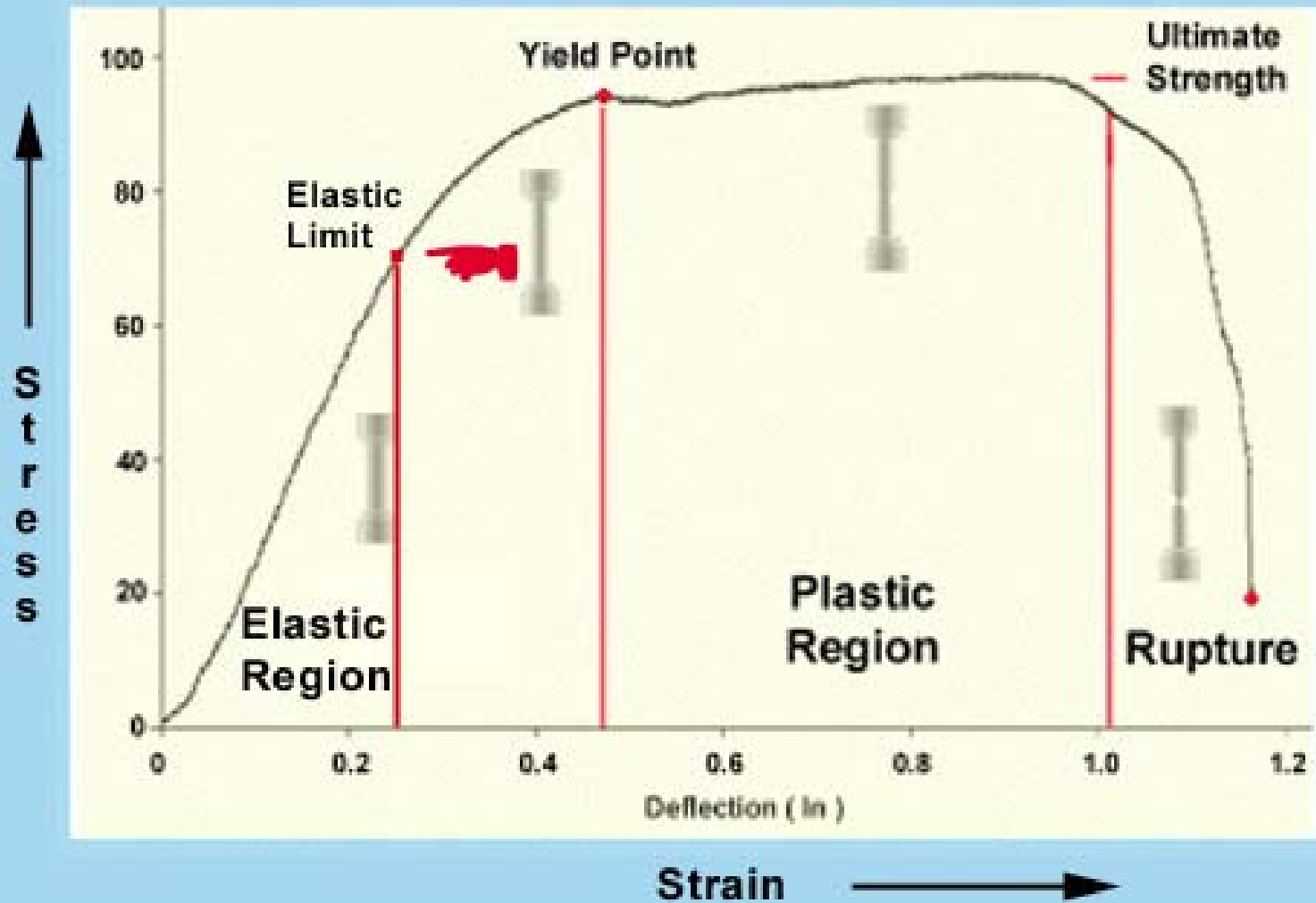



# Hooke's Law

Elastic deformation → Hooke's Law

$$\sigma = E \cdot \varepsilon$$

**E = Stiffness or Young's modulus or modulus of elasticity [GPa]**  
**Slope of the linear elastic portion of the  $\sigma$ - $\varepsilon$  curve**

**E ~ D (bond energy)**

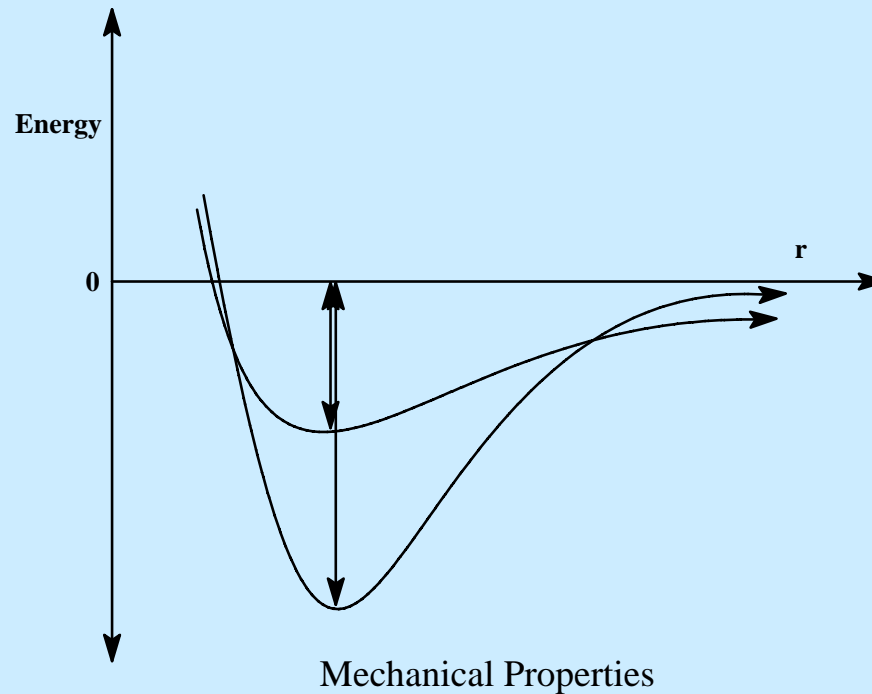

# Ductility

**Ductility is given by:**

**%Elongation (fractured specimen)**

**%Reduction in Cross Sectional Area**

**Metals 30-50%**

**Polymers >100%**

**Ceramics 0%**

# Poisson's Ratio

## Poisson's Ratio

The stress-strain curve does not show an important feature of plastic deformation: a contraction perpendicular to the extension caused by a tensile stress.

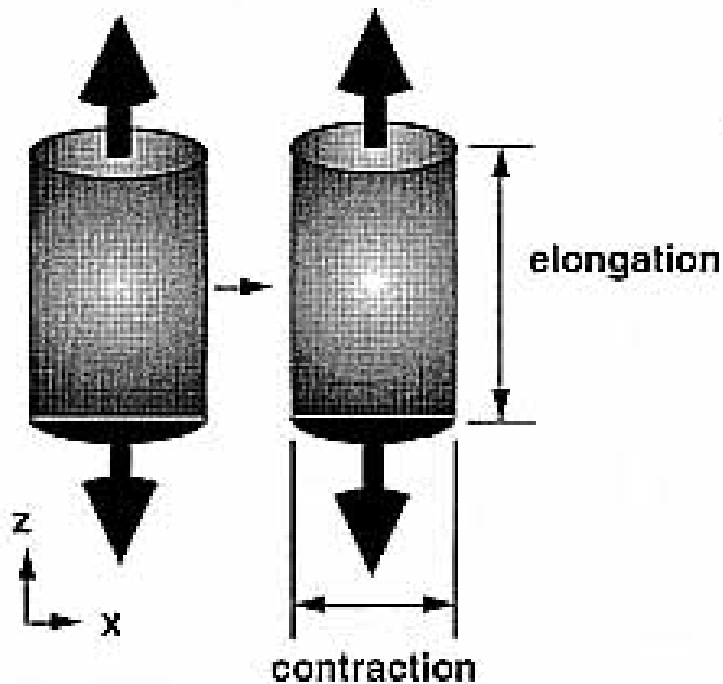

The effect is characterized by *Poisson's Ratio*:

$$\nu = - \frac{\epsilon_x}{\epsilon_z}$$

$\nu = 0.29$  for ductile iron  
 $\nu = 0.35$  for magnesium

# Bulk Modulus

**Bulk Modulus, B**      **Compressibility,  $\kappa$**

$$B = 1/\kappa$$

$$B = (N_c/4)(1971 - 220 I) r^{-3.5}$$

$N_c$       average coordination number

$r$       bond distance

$I$       ionicity    0 for Group 14 (diamond, Si)

1 for Group 13/15 (BN)

2 for Group 12/16 (ZnS)

$$B = \frac{A q^2 (n - 1)}{72 \pi \epsilon_0 r_0^4}$$

$A$	Madelung constant
$n$	Born coefficient
$q$	charge
$r_0$	bond distance

# Ductility and Brittleness

**Ductility – plastic deformation before fracture**

**Metals – slip, dislocations move easily**

**Brittleness – no plastic deformation**

**Ceramics – ionic, difficult to slip**

**– covalent – strong bonds**

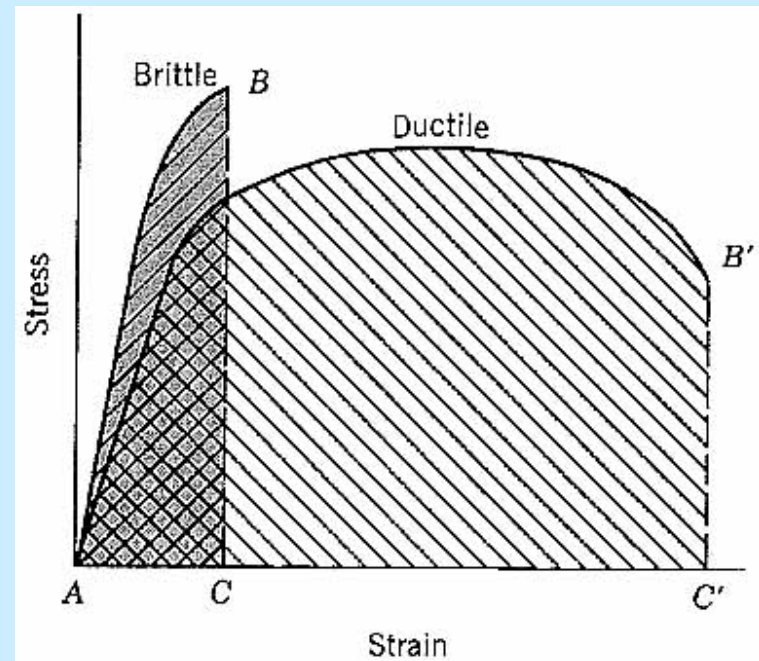

# Toughness

## Toughness

- energy absorbed by the material up to the point of fracture
- area under the  $\sigma$ - $\epsilon$  curve up to the point of fracture
- combination of high strength and medium ductility
- the ability of a material to resist fracture, plus the ability to resist failure after the damage has begun
- a tough metal can withstand considerable stress, slowly or suddenly applied, will deform before failure
- the ability of a material to resist the start of permanent distortion plus the ability to resist shock or absorb energy

# Toughness

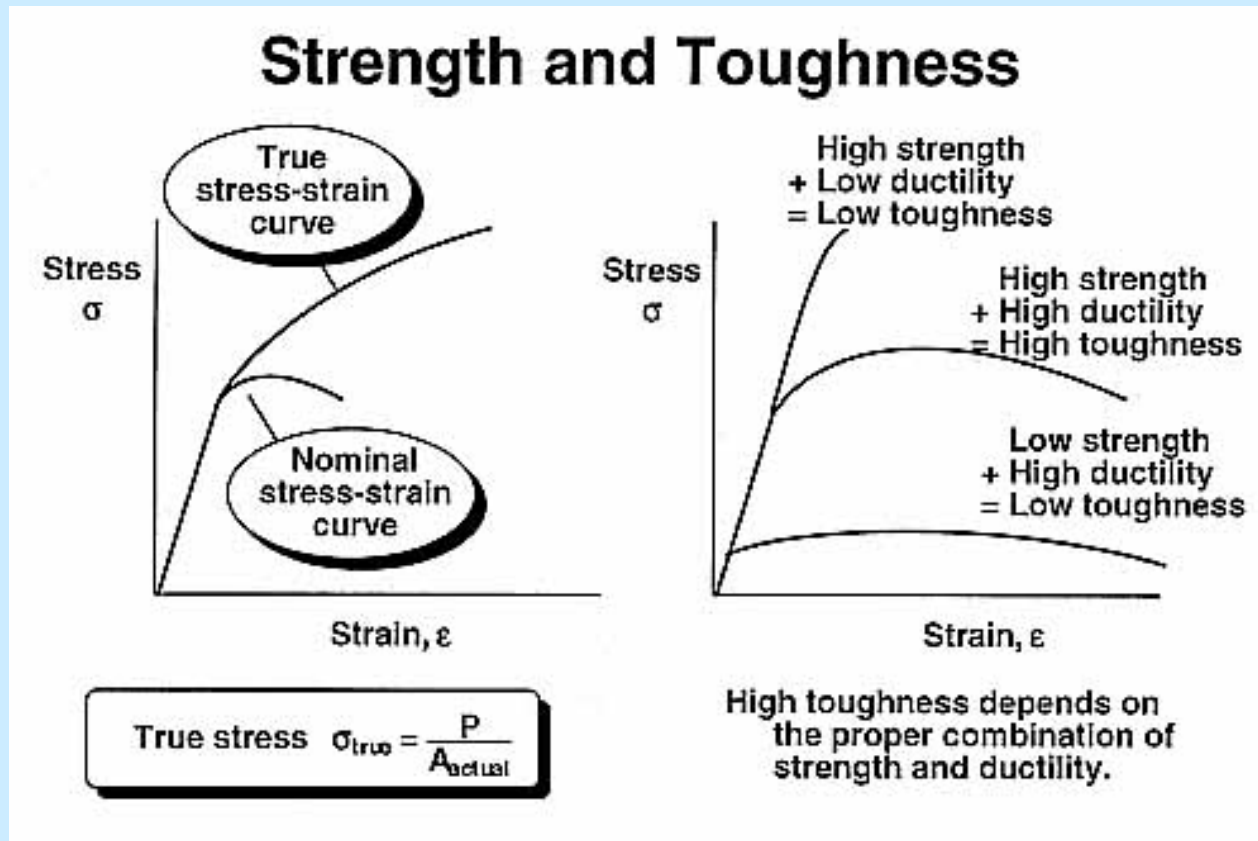

# Hardness

## Hardness

**Resistance to plastic deformation, usually by indentation**

**Stiffness or temper, or resistance to scratching, abrasion, or cutting**

**It is the property of a material, which gives it the ability to resist being permanently, deformed (bent, broken, or have its shape changed), when a load is applied.**

**The greater the hardness of the metal, the greater resistance it has to deformation.**

**Macro**

**Micro**

**Nano**



# Hardness

## Hardness

→ resistance to local plastic deformation

$$\sigma_{TS} = 3.55.HB \text{ [MPa]} \text{ (HB < 175)}$$

$$\sigma_{TS} = 3.38.HB \text{ [MPa]} \text{ (HB > 175)}$$

## Hardness scale

**Mohs scale**

**1 – 10, minerals**

**Rockwell HR**

**cone or sphere**

**Brinell HB**

**10 mm sphere**

**Vickers HV**

**diamond pyramid**

**Knoop HK**

**diamond pyramid**

**Berkovich HV**

**diamond pyramid**

**Shore HS**

**20° needle**

**(Durometer)**

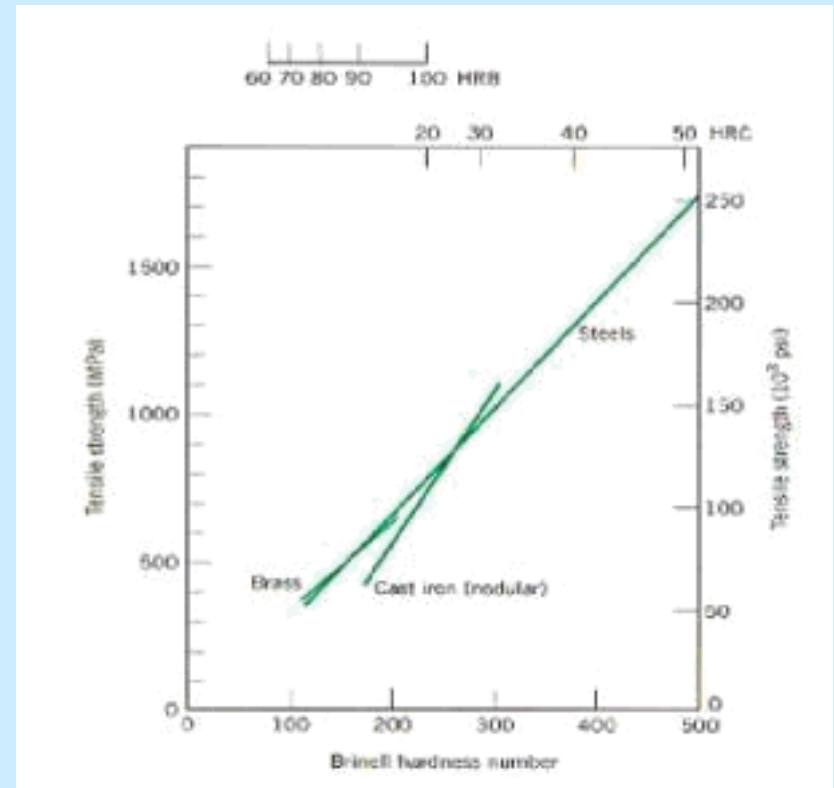

# Mohs scale

## Friedrich Mohs

Hardness of minerals, surface scratching  
nonlinear

not suitable for fine-grained, friable, or pulverulent materials

1	Talc
2	Gypsum $\text{CaSO}_4 \cdot 2\text{H}_2\text{O}$
3	Calcite $\text{CaCO}_3$
4	Fluorite $\text{CaF}_2$
5	Apatite $\text{Ca}_5(\text{PO}_4)_3(\text{OH})$
6	Orthoclase $\text{KAlSi}_3\text{O}_8$
7	Quartz $\text{SiO}_2$
8	Topaz $\text{Al}_2(\text{SiO}_4)(\text{F}/\text{OH})_2$
9	Corundum $\text{Al}_2\text{O}_3$
10	Diamond C

# Rockwell

Penetration depth of an indenter under a specified load

Rockwell	Indenter	Load, kg	Application
<b>B</b>	1.6 mm ball	100 kg	Soft steel, nonferrous metals
<b>T</b>	1.6 mm ball	15, 30, 45	Thin soft metals
<b>N</b>	120° diamond (brale)	15, 30, 45	Hard thin sheet metals
<b>A</b>	120° diamond (brale)	50	Cemented carbides
<b>R</b>	1.6 mm ball	10	Polymers
<b>C</b>	120° diamond (brale)	150	Hardened metals

# Indenters

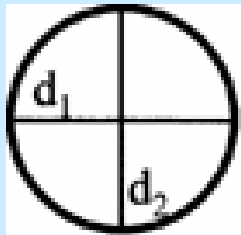

Brinell

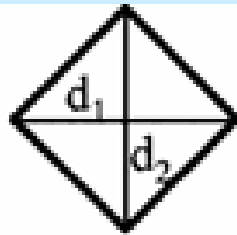

Vickers

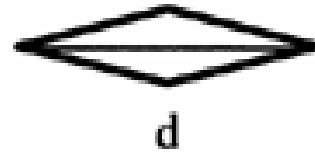

Knoop

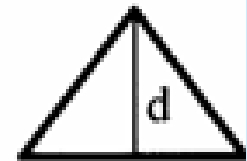

Berkovich

# Brinell (Germany)

Diameter of indentation made by a 10 mm ball (hardened steel or WC) under a specified load (500, 1500, 3000 kg) for a specified time (10, 15, 30 s)

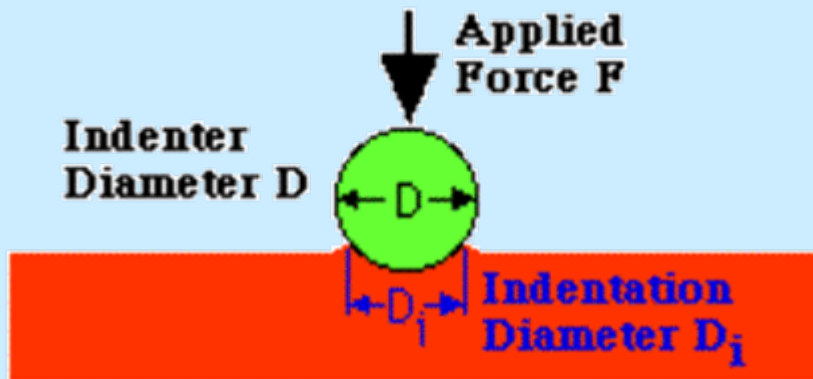

$$\text{BHN} = \frac{F}{\frac{\pi}{2} D \cdot (D - \sqrt{D^2 - D_i^2})}$$

HB = the Brinell hardness number

F = the imposed load in kg

D = the diameter of the spherical indenter in mm

$D_i$  = diameter of the resulting indenter impression in mm

# Vickers (UK)

**Diamond pyramid indenter**

$$HV = 1.8544(F/d^2)$$

**F**      load [kg]  
1-120 kg

**d**      diagonal of a square  
indentation [mm]

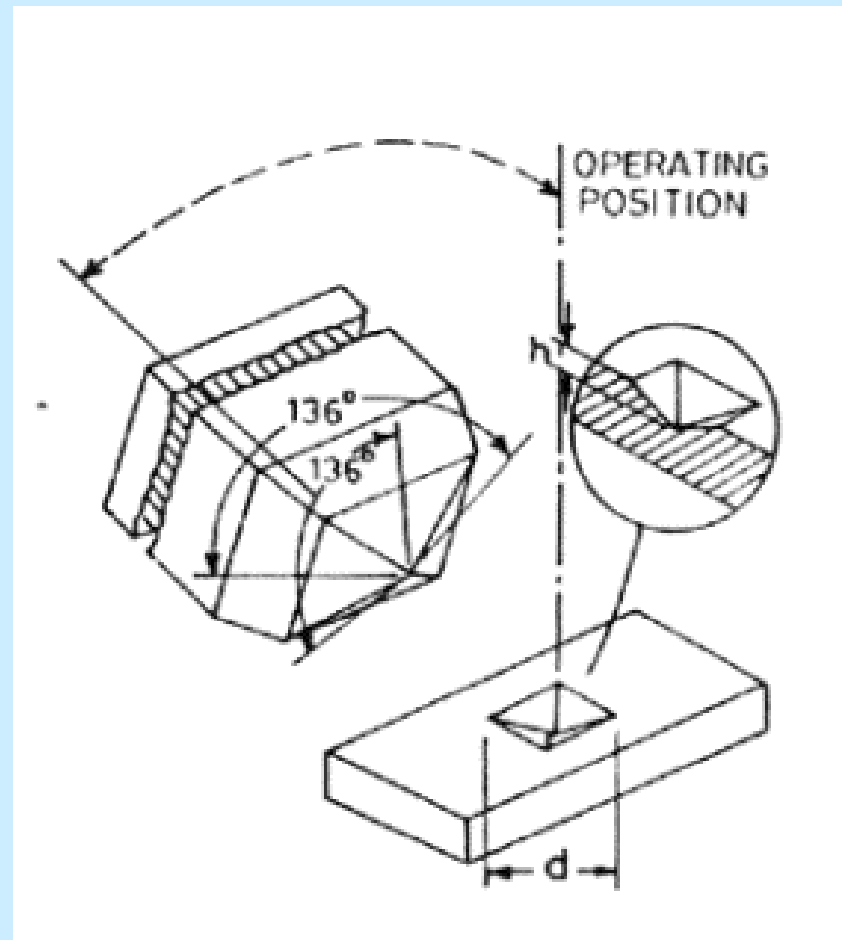

**A comparison of the deformation around an indentation as a function of the force applied.**

**For (A), a 100-g load was applied, resulting in a 41-  $\mu\text{m}$ -diameter indent, while for (B), a 10-kg load was applied, resulting in a 410-  $\mu\text{m}$ -diameter indent.**

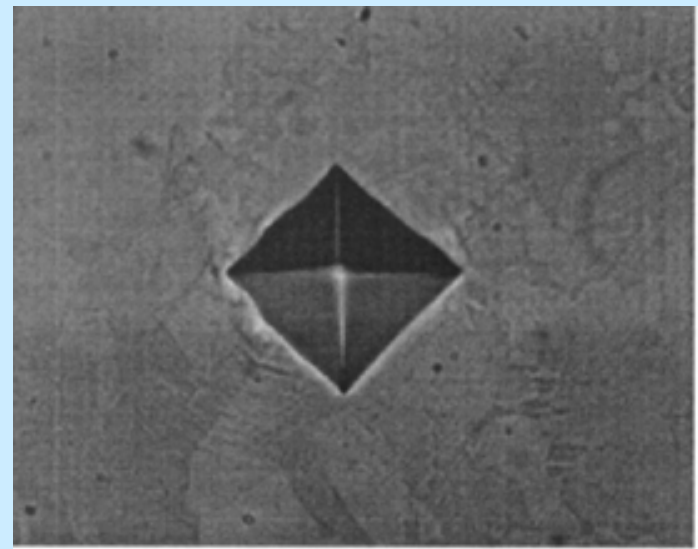

550X

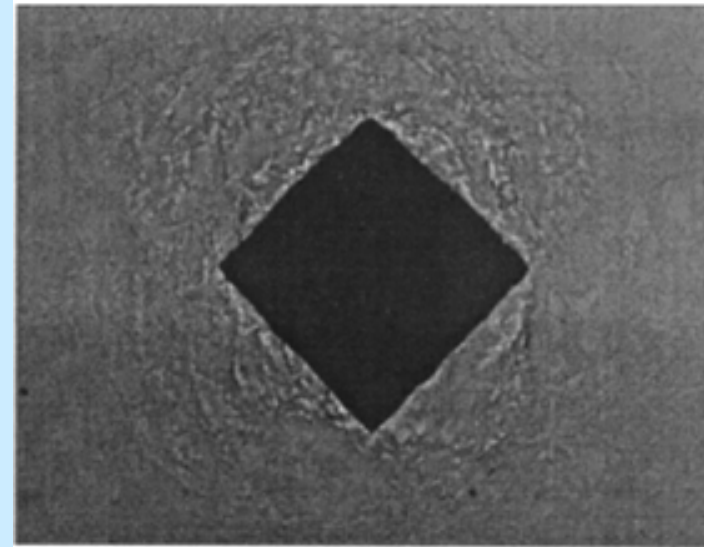

75X

# Knoop (US)

**Diamond pyramid indenter**

$$HK = 14.2294(F/l^2)$$

**F**      load [kg]  
1 - 1000 g

**l**      long diagonal of  
a rhombohedral  
impression [mm]

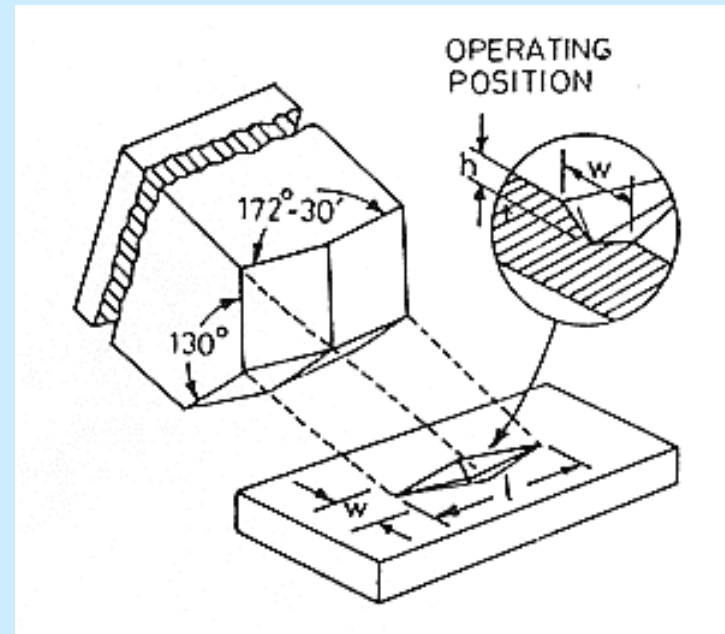



# Berkovich

**Triangular diamond pyramid  
indenter 115°**

$$\mathbf{HK = 1.5677(F/d^2)}$$

**F**        **load [kg]**  
**1 - 1000 g**

**d**        **long diagonal of**  
**a triangular**  
**impression [mm]**

# Shore (Durometer)

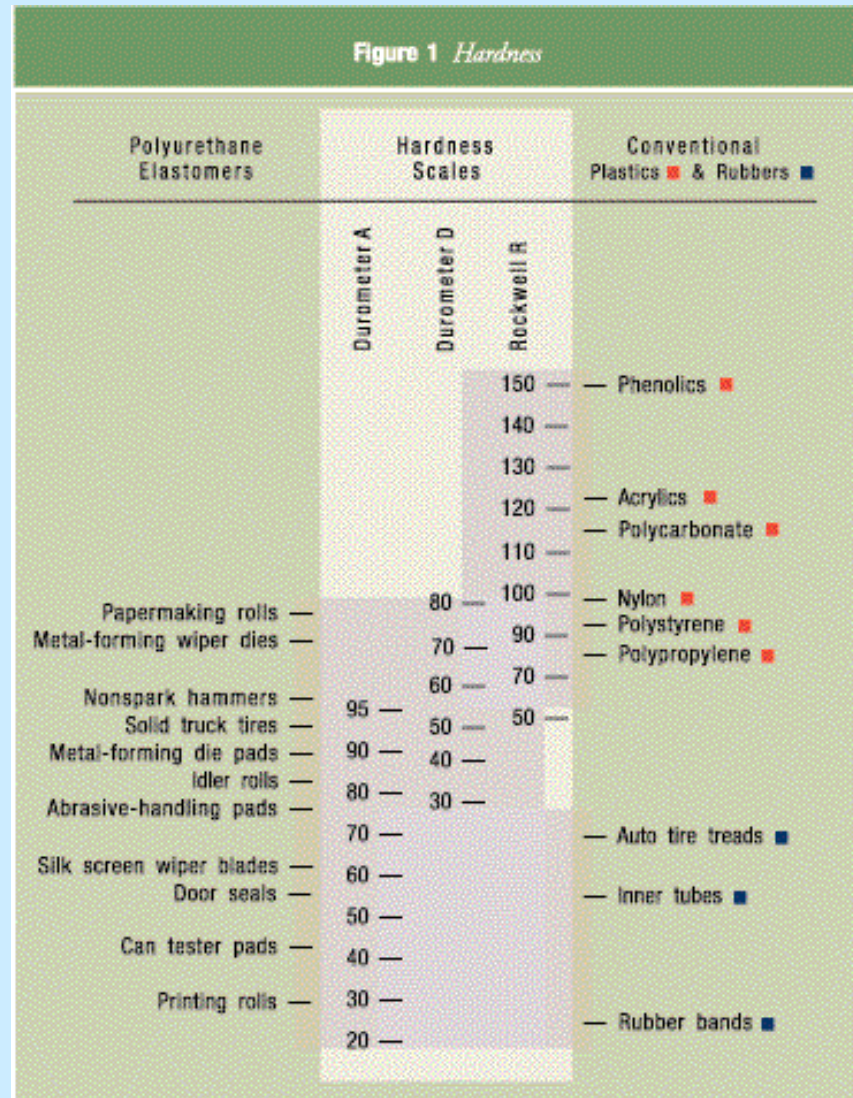

### Common Applications and Nomenclature for Hardness Tests

Test	Abbreviation	Indenter	Test load (kg)	Application
Brinell	HBW	10-mm ball: tungsten carbide	3000	cast iron and steel
Brinell	HBS	10-mm ball: steel	500	copper, aluminum
Rockwell A	HRA	brale	60	very hard materials, cemented carbides
Rockwell B	HRB	$\frac{1}{16}$ -in. ball	100	low-strength steel, copper alloys, aluminum alloys, malleable iron
Rockwell C	HRC	brale	150	high-strength steel, titanium, pearlitic malleable iron
Rockwell D	HRD	brale	100	high-strength steel, thin steel
Rockwell E	HRE	$\frac{1}{8}$ -in. ball	100	cast iron, aluminum, and magnesium alloys
Rockwell F	HRF	$\frac{1}{16}$ -in. ball	60	annealed copper alloys, thin soft metals
Superficial Rockwell T	30 T	$\frac{1}{16}$ -in. ball	30	materials similar to Rockwell B, F, and G, but of thinner gauge
Superficial Rockwell N	30 N	brale	30	materials similar to Rockwell A, C, and D, but of thinner gauge
Vickers	HV	diamond	10	hard materials, ceramics, cemented carbides
Vickers	HV	diamond	0.5	all materials
Knoop	HK	diamond	0.5	all materials, case-depth determination

Rockwell C Scale	Brinell Hardness	Vickers Hardness	Tensile Strength (approx.)		Rockwell C Scale	Brinell Hardness	Vickers Hardness	Tensile Strength (approx.)	
Brale Penetrator	10mm Tungsten Carbide Ball	Pyramidic Diamond			Brale Penetrator	10mm Tungsten Carbide Ball	Pyramidic Diamond		
150kgf	3,000kgf	10kgf	ksi	kg/mm <sup>2</sup>	150kgf	3,000kgf	10kgf	ksi	kg/mm <sup>2</sup>
67	—	900	—	—	43	400	423	201	141
66	—	865	—	—	42	390	412	196	138
65	739	832	—	—	41	381	402	191	134
64	722	800	—	—	40	371	392	186	131
63	705	772	—	—	39	362	382	181	127
62	688	746	—	—	38	353	372	176	124
61	670	720	—	—	37	344	363	172	121
60	654	697	—	—	36	336	354	167	118
59	634	674	329	232	35	327	345	163	114
58	615	653	319	224	34	319	336	159	112
57	595	633	307	216	33	311	327	154	109
56	577	613	297	209	32	301	318	149	105
55	560	595	288	202	31	294	310	146	102
54	543	577	279	196	30	286	302	142	99
53	525	560	269	189	29	279	294	138	97
52	512	544	262	184	28	271	286	134	94
51	496	528	253	178	27	264	279	130	92
50	481	513	245	172	26	258	272	127	89
49	469	498	238	167	25	253	266	125	88
48	455	484	231	162	24	247	260	122	85
47	443	471	224	158	23	243	254	120	84
46	432	458	218	153	22	237	248	116	82
45	421	446	212	149	21	231	243	113	80
44	409	434	206	145	20	226	238	111	78

For the source of Rockwell, Brinell and Vickers Hardness data see endnote 4.

### Aproximate Comparison of Hardness Scales

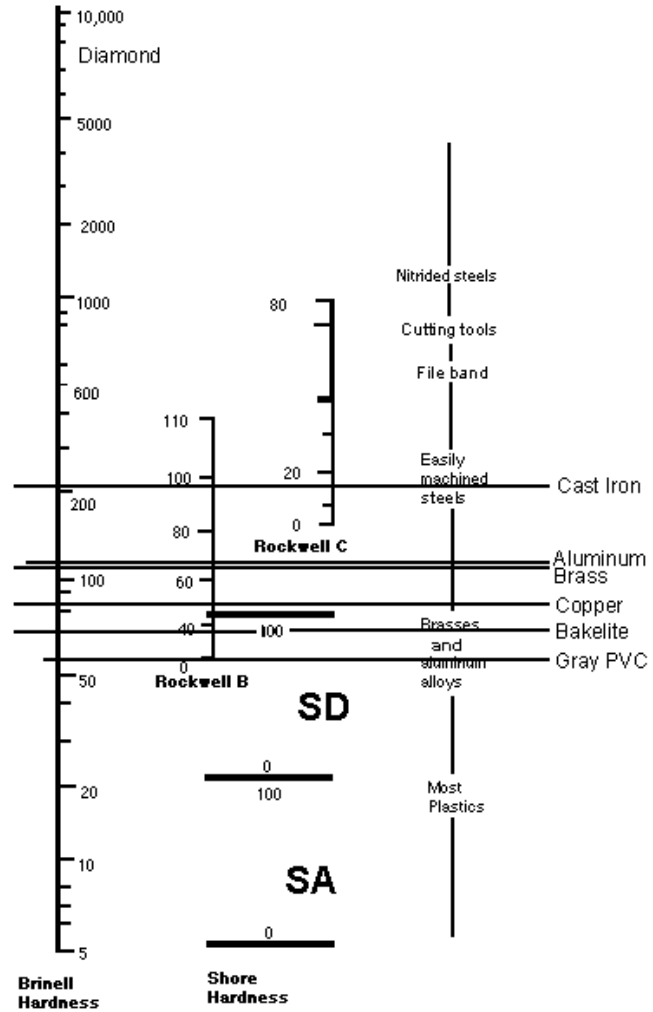

Mark Doggett IT 283

# Ceramics

## Transverse bend test

$\sigma_{FS}$  = Flexural strength, Fracture strength, Modulus of rupture

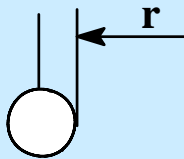
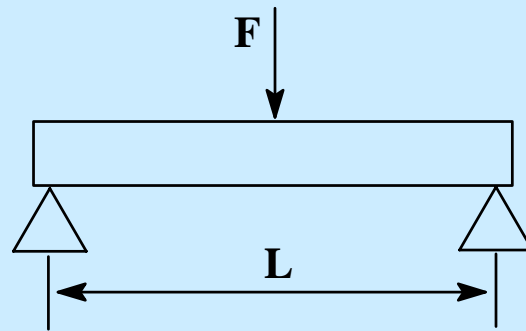

$$\sigma_{FS} = \frac{FL}{\pi r^3}$$

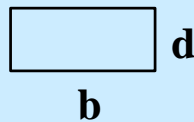

$$\sigma_{FS} = \frac{3FL}{2bd^2}$$

# Ceramics

✿ only elastic deformation at room temperature

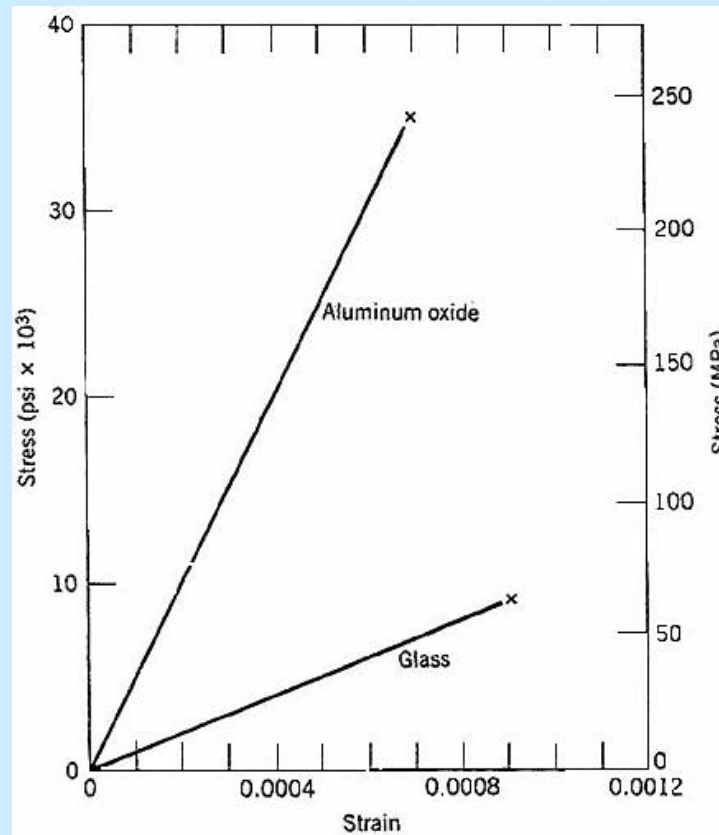

# Ceramics

✿ voids dominate behavior

$$E = E_0(1 - 1.9P + 0.9P^2)$$

$E_0$  elasticity modulus of the nonporous material

$P$  volume fraction porosity

$$\sigma_{FS} = \sigma_0 \exp(-nP)$$

$n, \sigma_0$  experimental constants

✿ tension not the same as compression

tensile strength is one-tenth of compressive strength !!!!



# Ceramics

✳ strength determined by the largest flaws, sample size dependent

L. DaVinci: The longer the wire, the smaller the load to fail it.

Weibull statistical theory of strength

$$\sigma_x = \frac{A}{V^{-n}}$$

**A, n** materials constants  
**V** volume of material

# Superplasticity in Ceramics

**ZrO<sub>2</sub>, SiC, Si<sub>3</sub>N<sub>4</sub>, SiYAION**

**Grain boundary sliding at elevated temperatures, grains wetted with glass phase, viscous fluid acts as a lubricant, equiaxed fine grains  
solution-precipitation, diffusion**

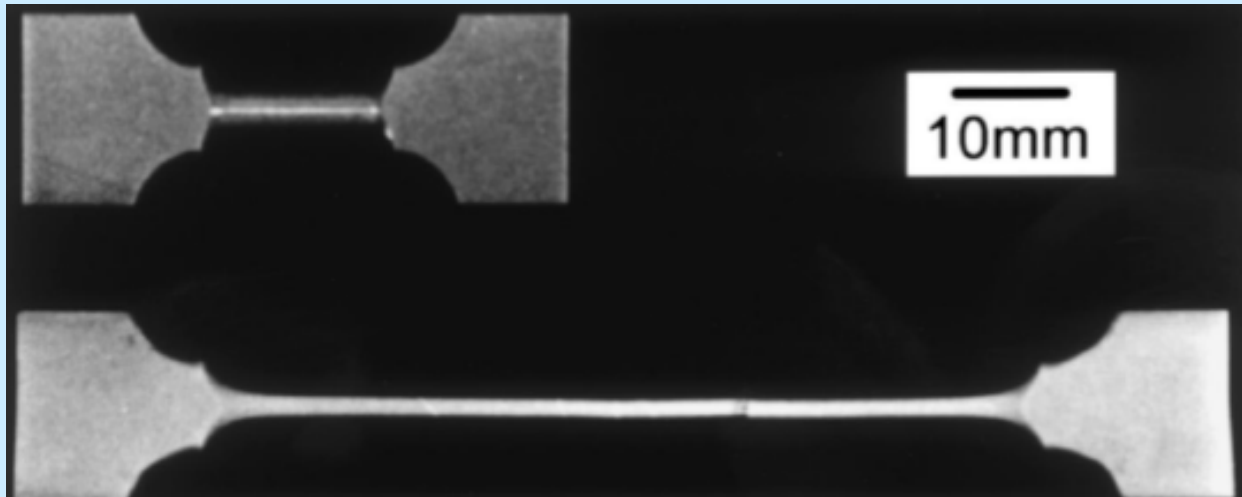

**SiAlON 470% elongation**

# Surface Roughness

$R_a$  = arithmetic average of the peak-to-valley height of surface asperities [ $\mu\text{m}$ ]

Profilometer, stylus of finite radius (2, 5, 10  $\mu\text{m}$ ) cannot reach the bottom of valleys

True roughness =  $4 \times R_a$

AFM Atomic force microscopy, stylus 100 angstrom

