

ŠÍŘENÍ SIGNÁLŮ A SYNAPSE



Šíření signálů a synapse

Synapse, místa přerušení elektrického vedení.

AP a místní potenciály.

Zpomalení, převod na chemickou řeč.

Neurony tedy nekomunikují pouze AP, ale i chemicky.

Obecná citlivost neuronů i na chemickou modulaci.

Existuje i mimosynaptický přenos - informační polévka.

Prostor pro zpracování informací.

Plasticita a paměť

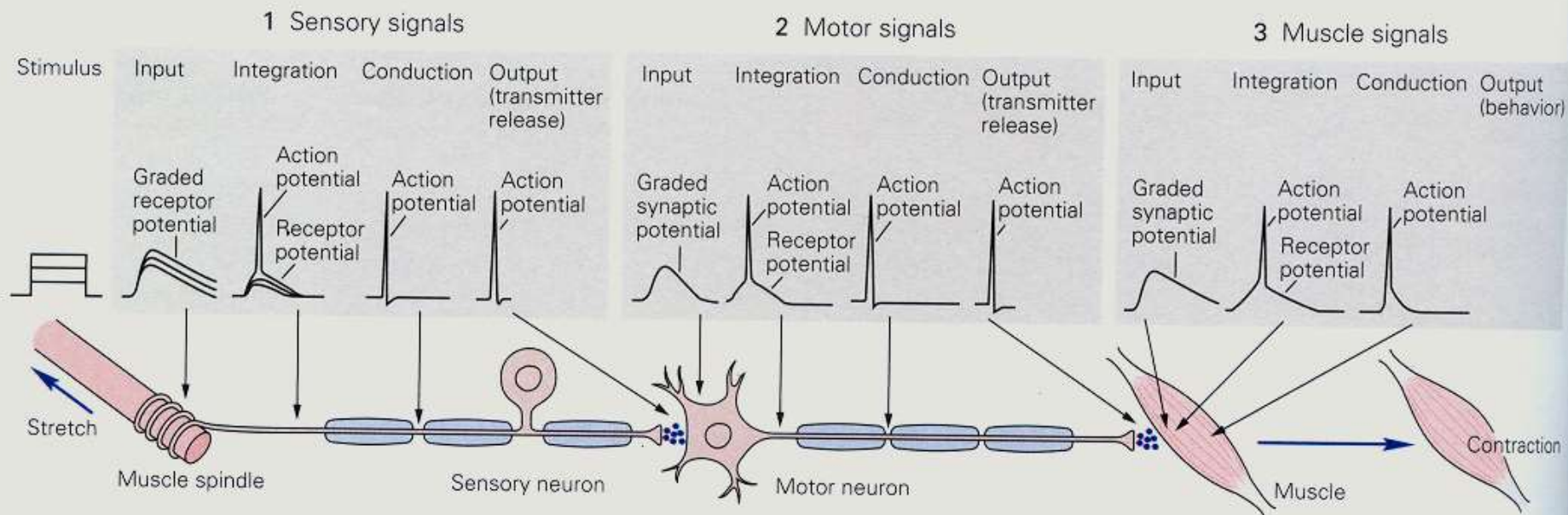

Od místa vzniku k dalšímu neuronu.

Šíření podél membrány.
Kromě příčného i podélný tok iontů.
Záleží na průměru.

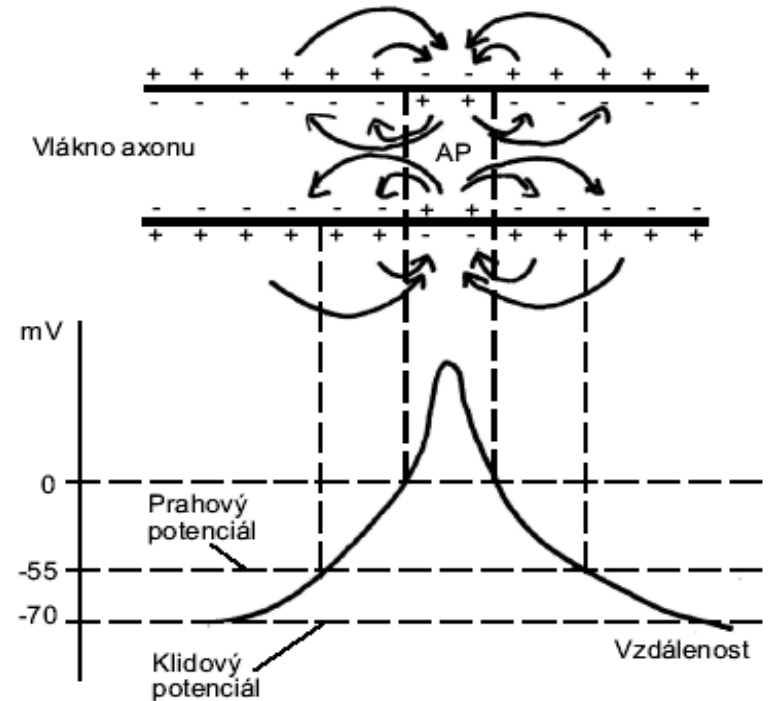
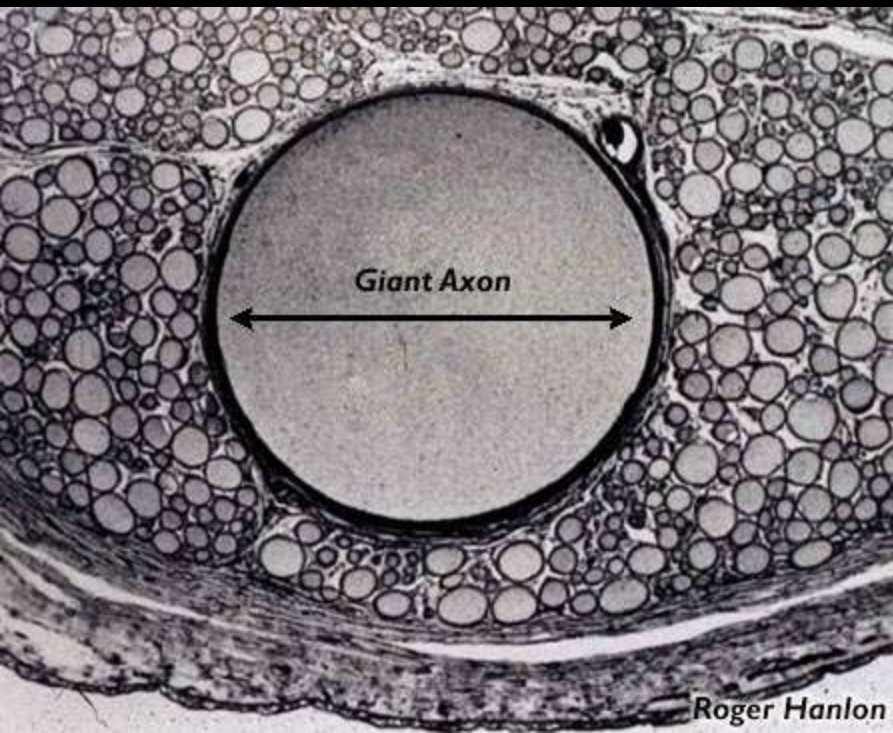

Obr. 4.6. Šíření akčního potenciálu (AP). Jestliže je jedno místo excitabilní membrány depolarizováno, podélné iontové toky (šipky) vyvolají rozšíření depolarizace i do bezprostředního okolí. Nové AP mohou vznikat všude, kde byl překročen prahový potenciál. Děj se opakuje a vlna vznikajících depolarizací se šíří podél membrány.



Propagace, voltage clamp

nemyelinizovaný
myelinizovaný

► Myelination of PNS and CNS Axons

Myelination in the Peripheral Nervous System

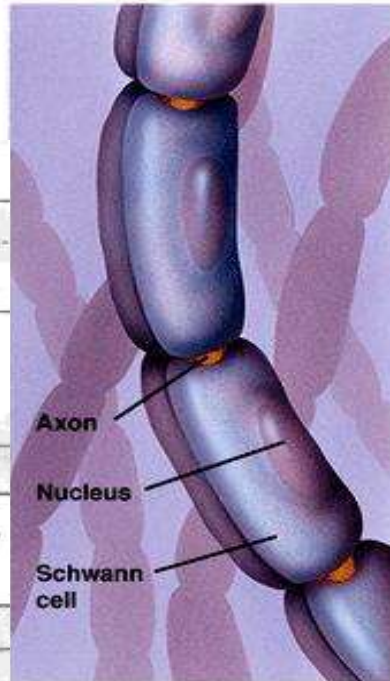

Myelination in the Central Nervous System

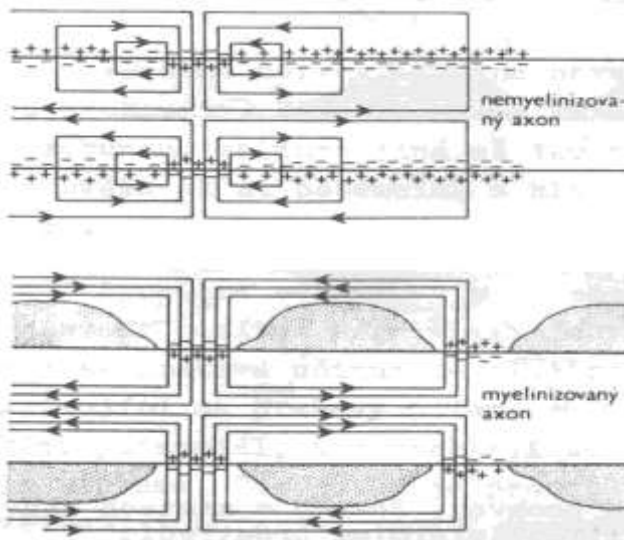
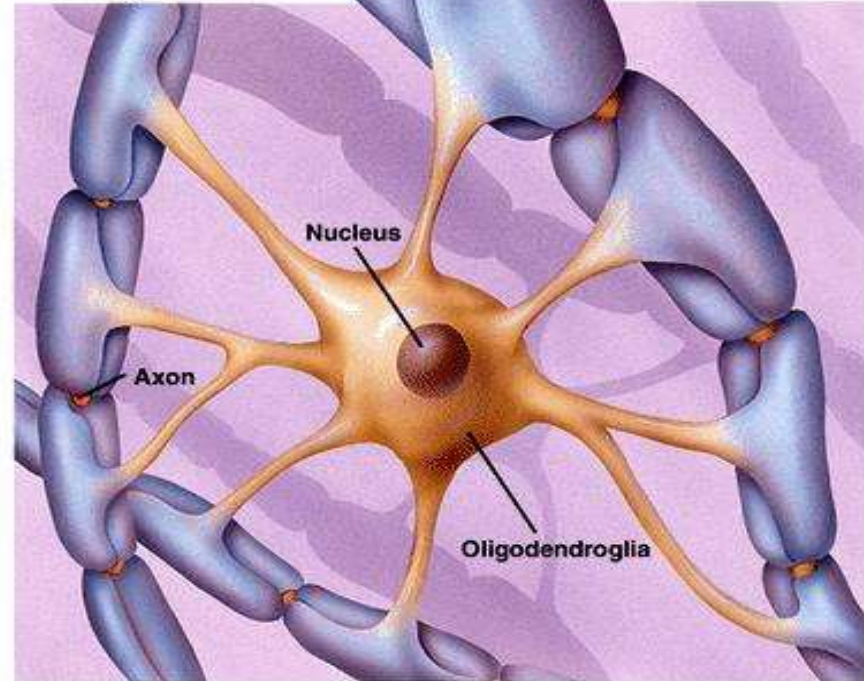

Šíření podél membrány.

Záleží i na myelinizaci.

Žabí myelinizovaný neuron má při 20°C a 12um rychlost vedení 25m/s. Nemyelinizovaný neuron sépie musí mít pro stejnou rychlost průměr 500um! Je to 40x menší průměr a 1600x plocha.

Synapse

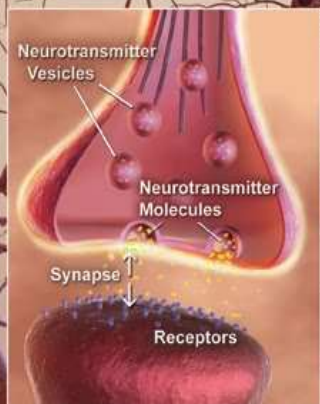

Axons

Dendrites

Neuron

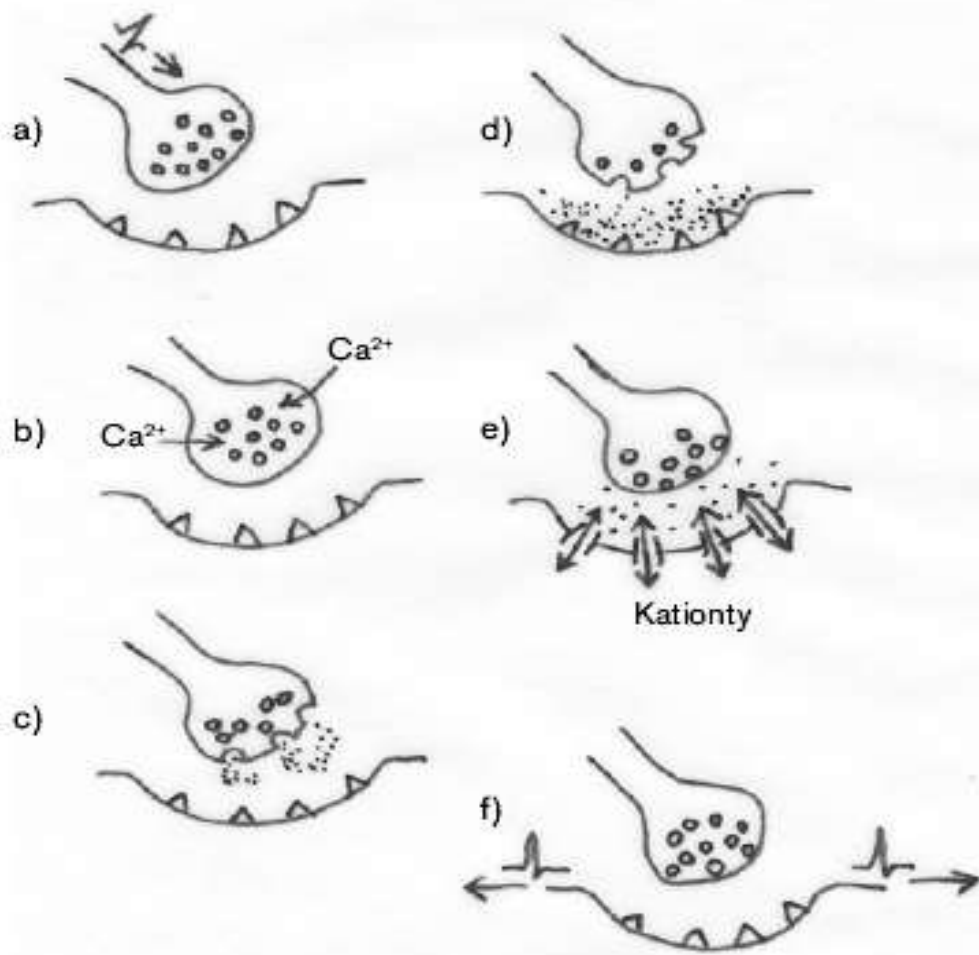

Obr. 4.7. Sekvence dějů při předání akčního potenciálu (AP) prostřednictvím mediátoru na chemické synapsi. a) přicházející AP depolarizuje synaptický knoflík, b) otvírají se vápníkové kanály a Ca^{2+} proudí do nitra knoflíku, c) to vyvolá exocytózu granul s mediátorem, d) mediátor se váže na receptory postsynaptické membrány, e) následuje otevření kanálů pro kationty a jejich vtok způsobí místní depolarizaci, f) na napěťově citlivém okolí synapse mohou vzniknout nové AP.

Synapse

Synapse v kontextu buněčných spoju

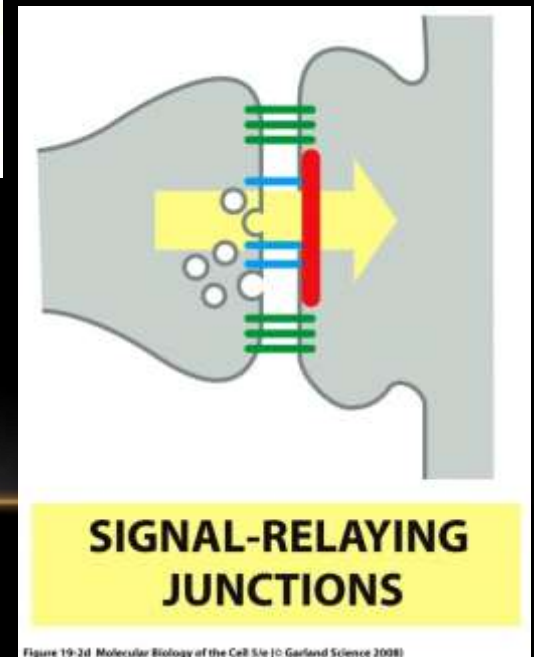
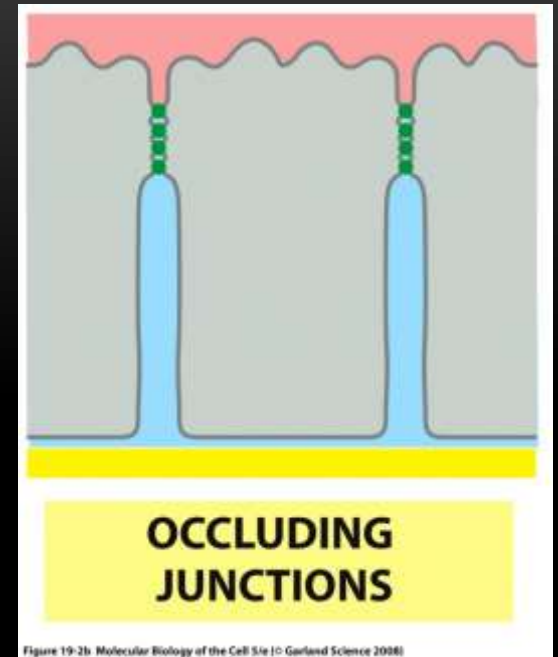
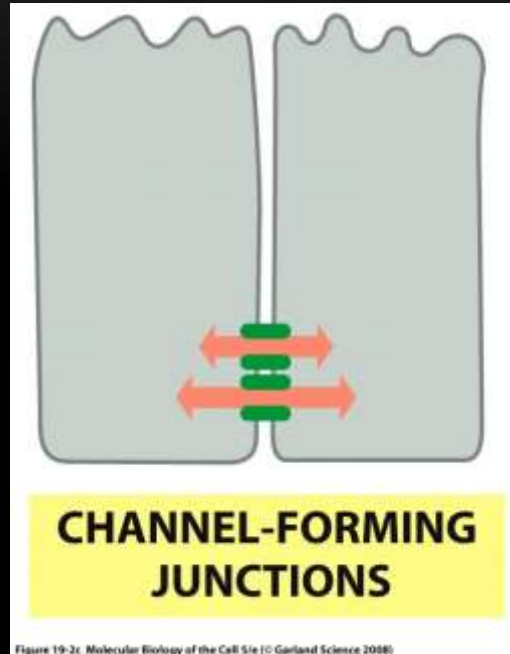
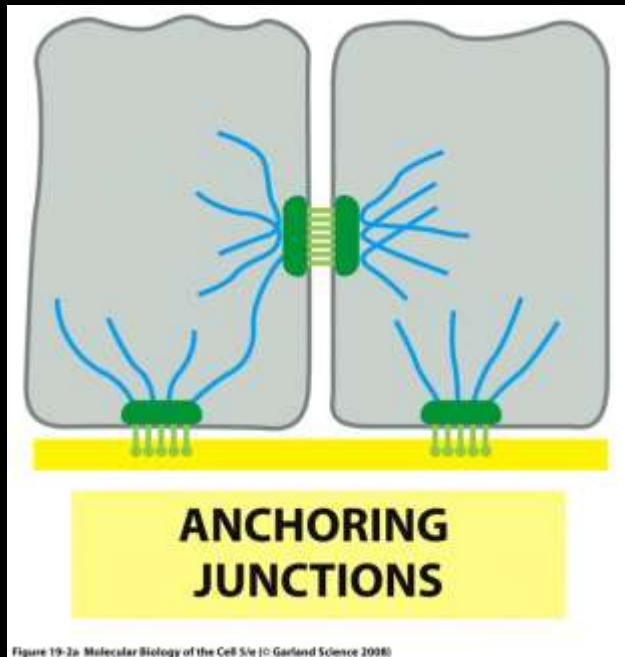

The Nobel Prize in Physiology or Medicine 1970



"for their discoveries concerning the humoral transmitters in the nerve terminals and the mechanism for their storage, release and inactivation"



Sir Bernard Katz



1/3 of the prize

United Kingdom

University College
London, United Kingdom

b. 1911
d. 2003



Ulf von Euler



1/3 of the prize

Sweden

Karolinska Institutet
Stockholm, Sweden

b. 1905
d. 1983



Julius Axelrod

1/3 of the prize

USA

National Institutes of Health
Bethesda, MD, USA

b. 1912
d. 2004

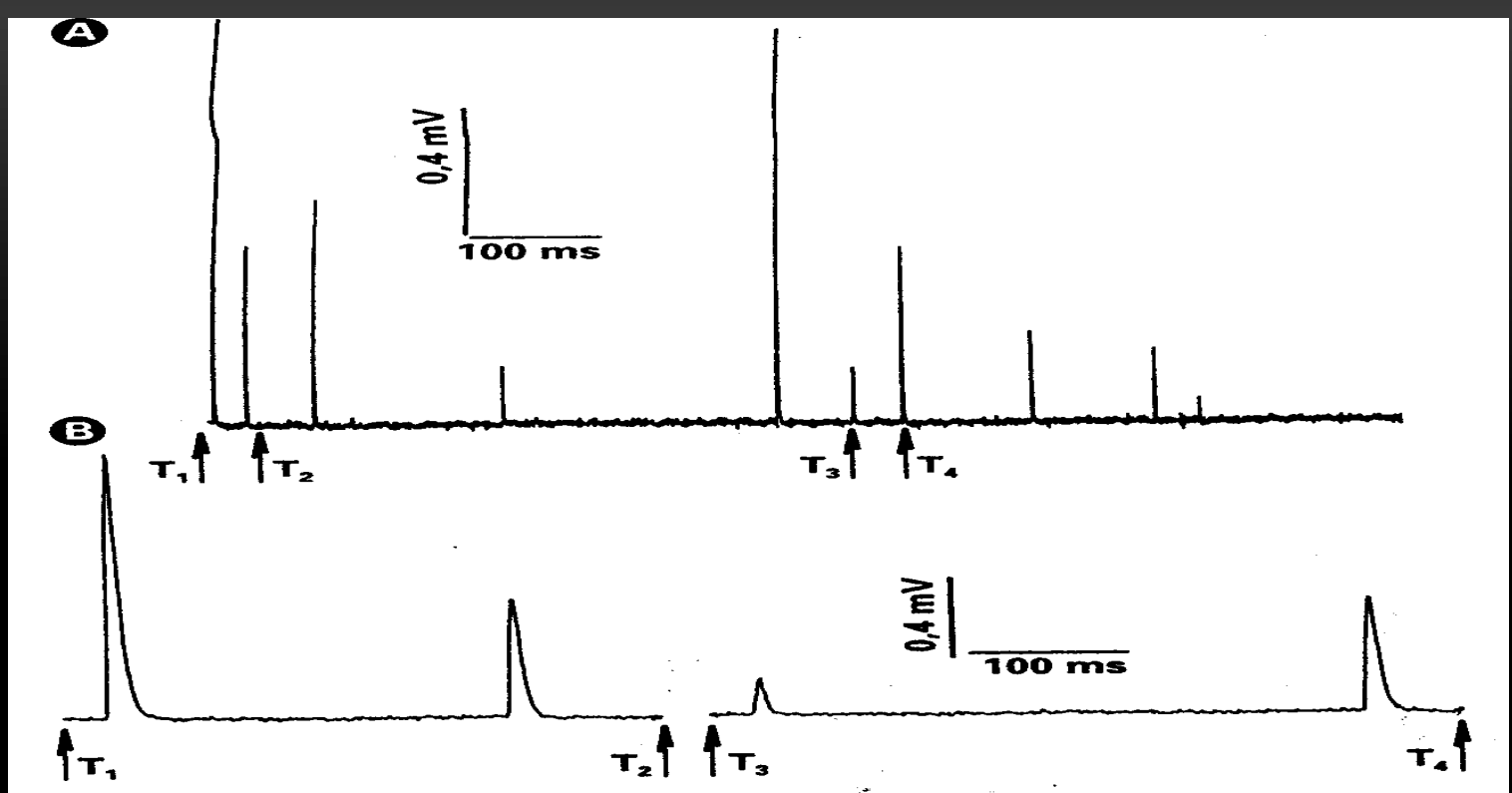

Sir Bernard Katz, 1970
Kvantovaný přenos

Second messengers,
synapses

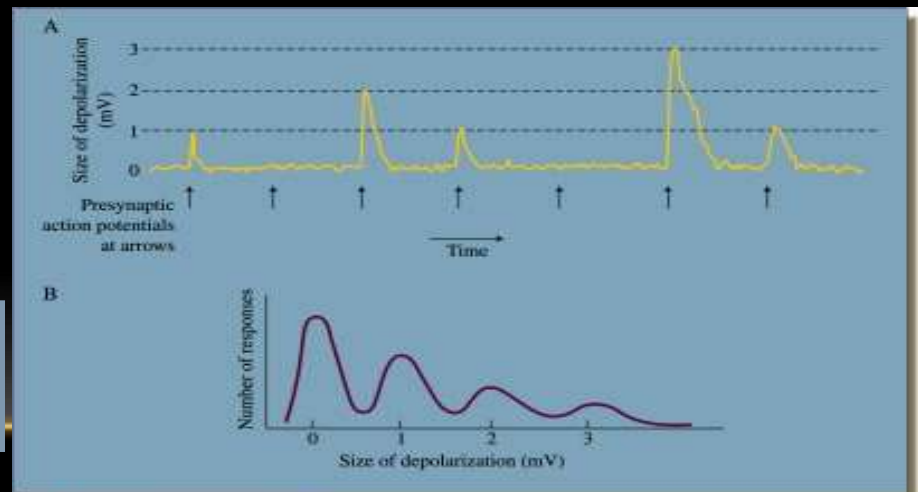

Receptor je součástí kanálu – ionotropní signalizace
 nebo spojen s kanálem kaskádou signálů – metabotropní signalizace

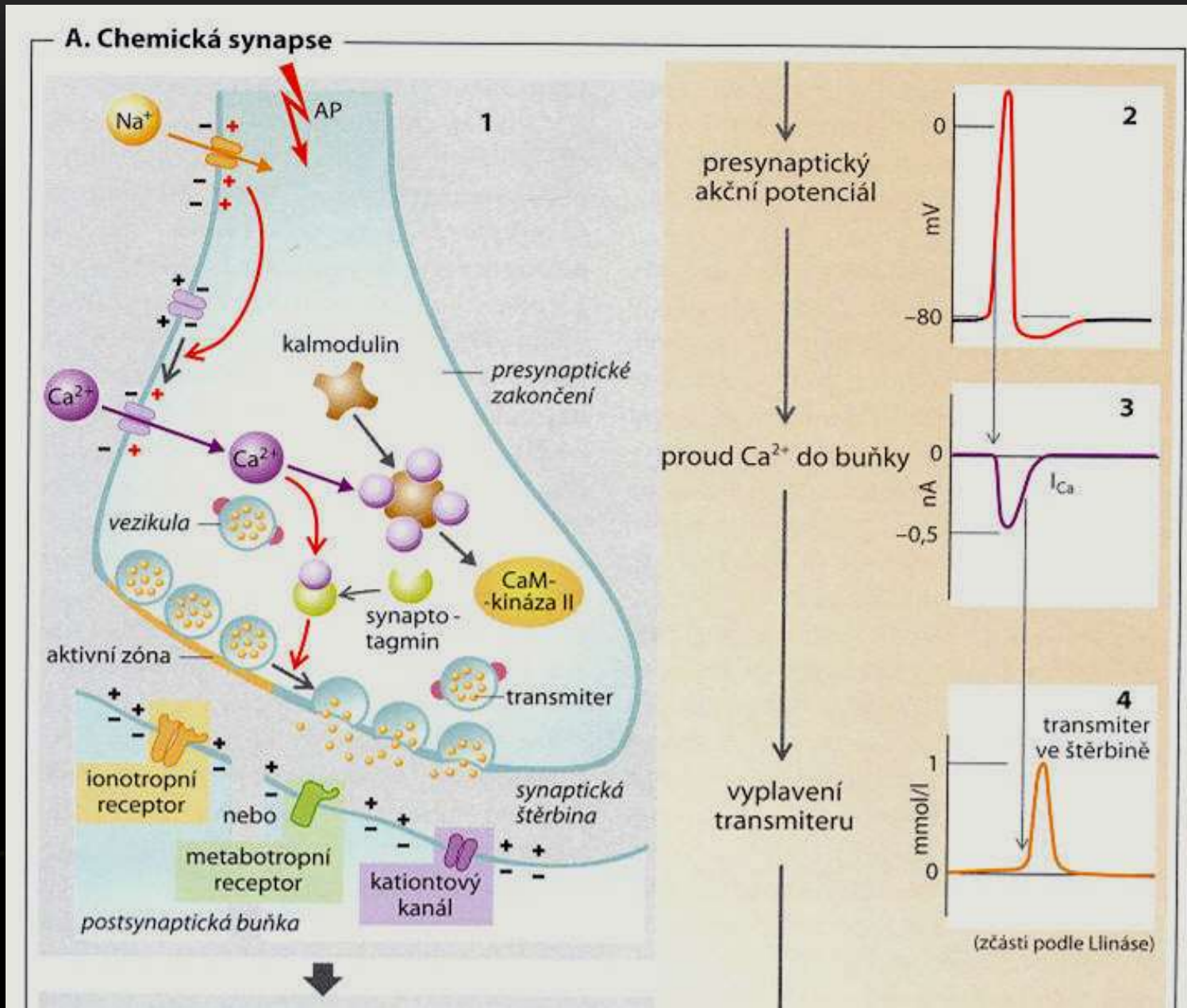

Tab. 2.5 Synaptický přenos I

Ach receptor je ionotropní. Je to pentamer, podobný receptoru pro serotonin, GABA, glycin.
Avšak Glut. receptor je tetramer, podobný K kanálu.

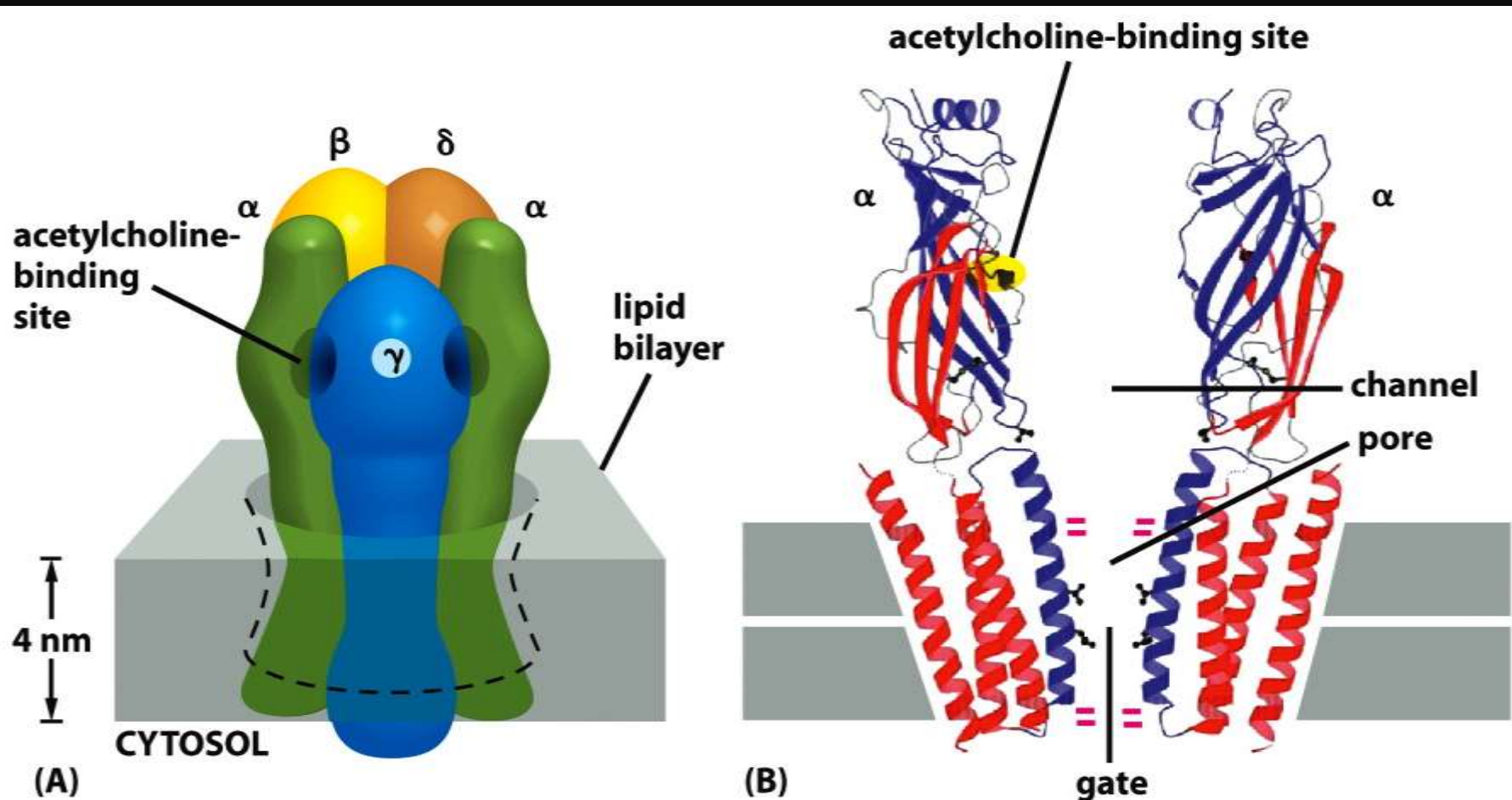
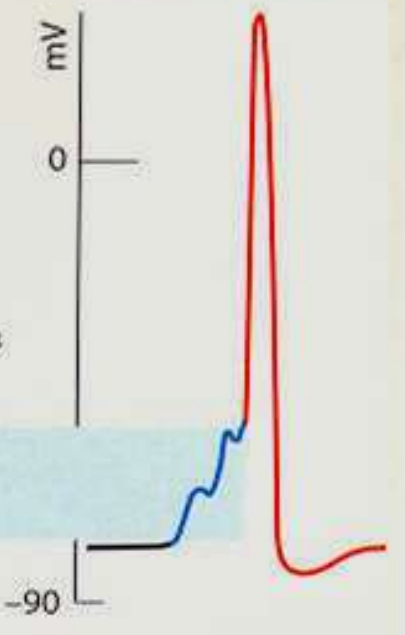
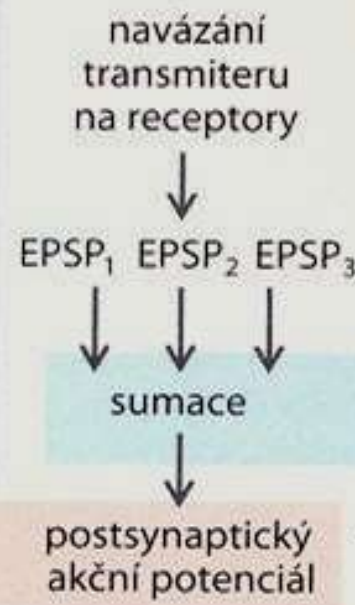
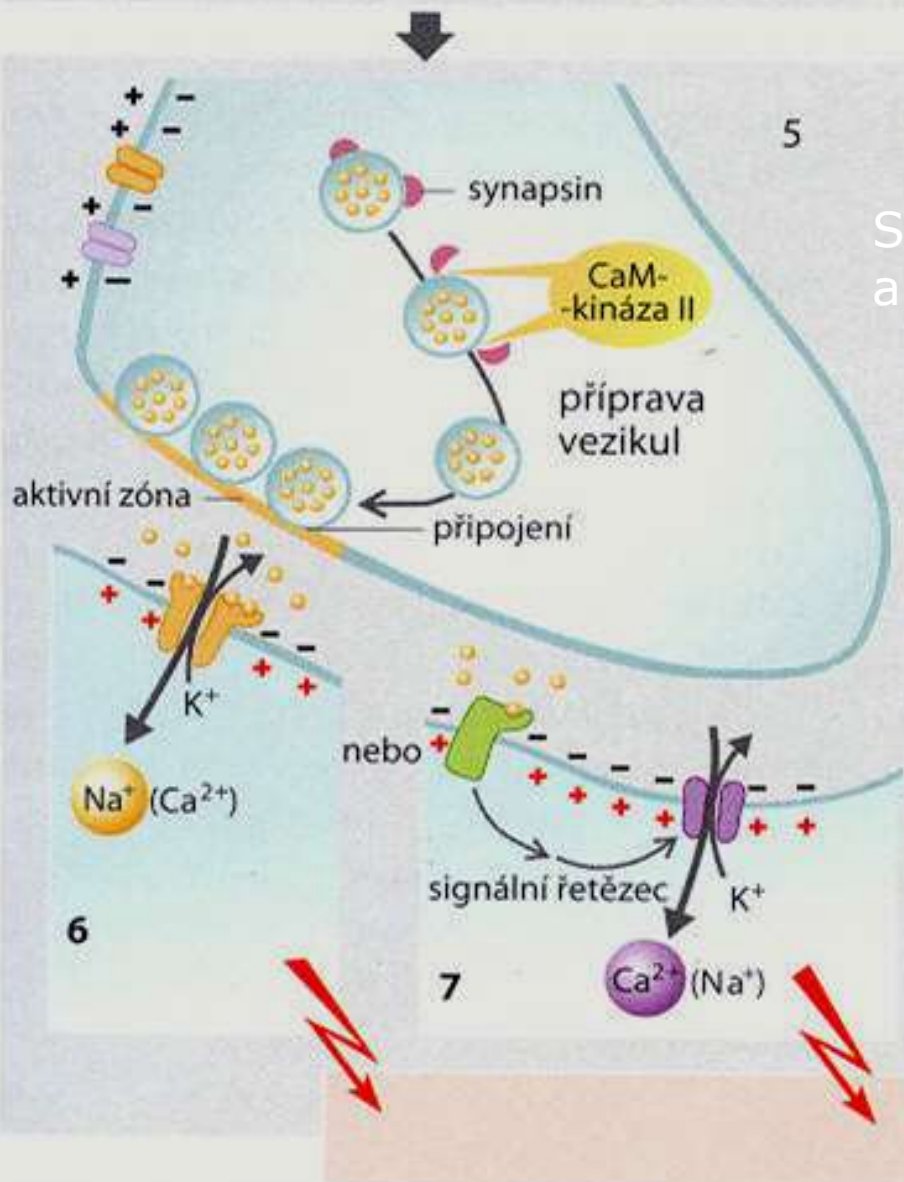

Figure 11-38 Molecular Biology of the Cell 5/e (© Garland Science 2008)

Synapsin = znovuhromadění v aktivní zóně



(viz tab. B)

Coatmer clathrin nutný pro udržení tvaru vesikulu

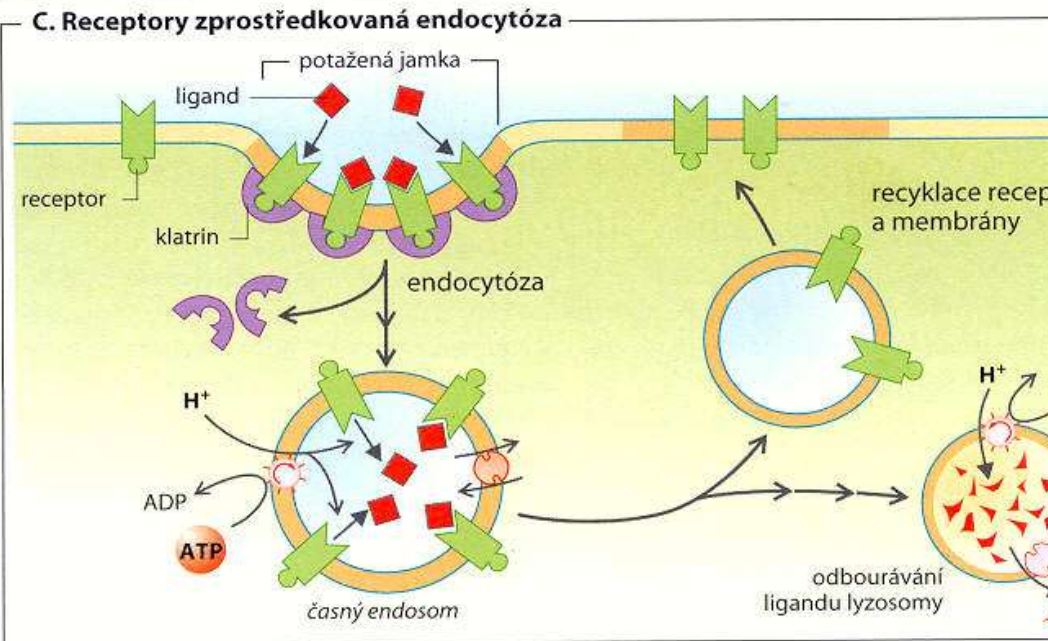

(a) Overview of vesicle recycling

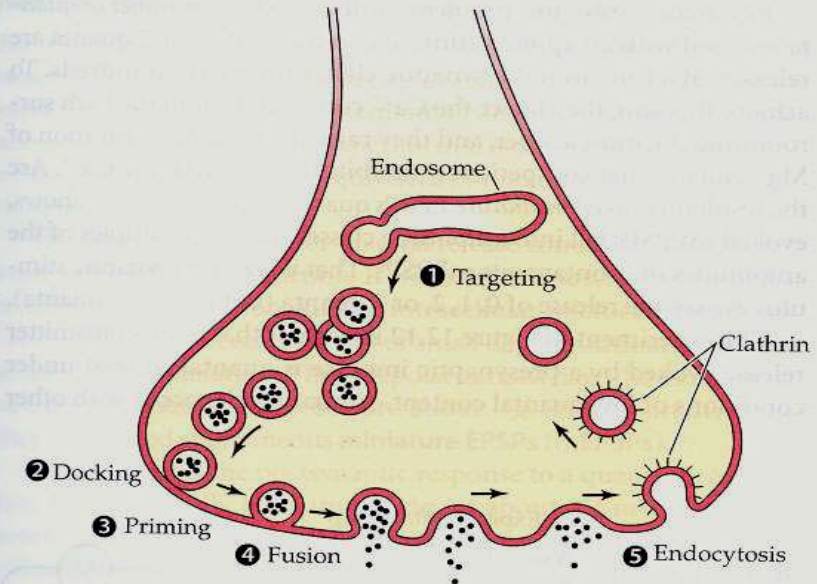

(b) Retrieval of the vesicular membrane

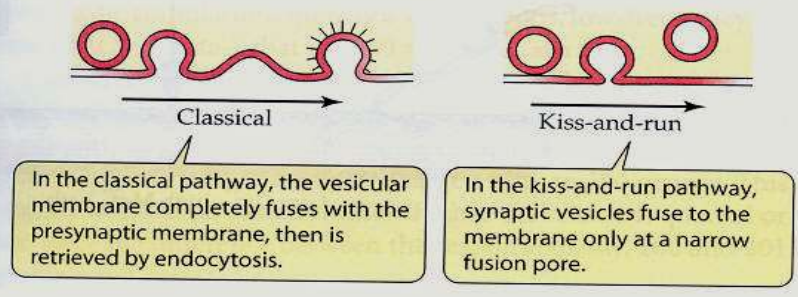

Syntéza v knoflíku nebo v těle neuronu

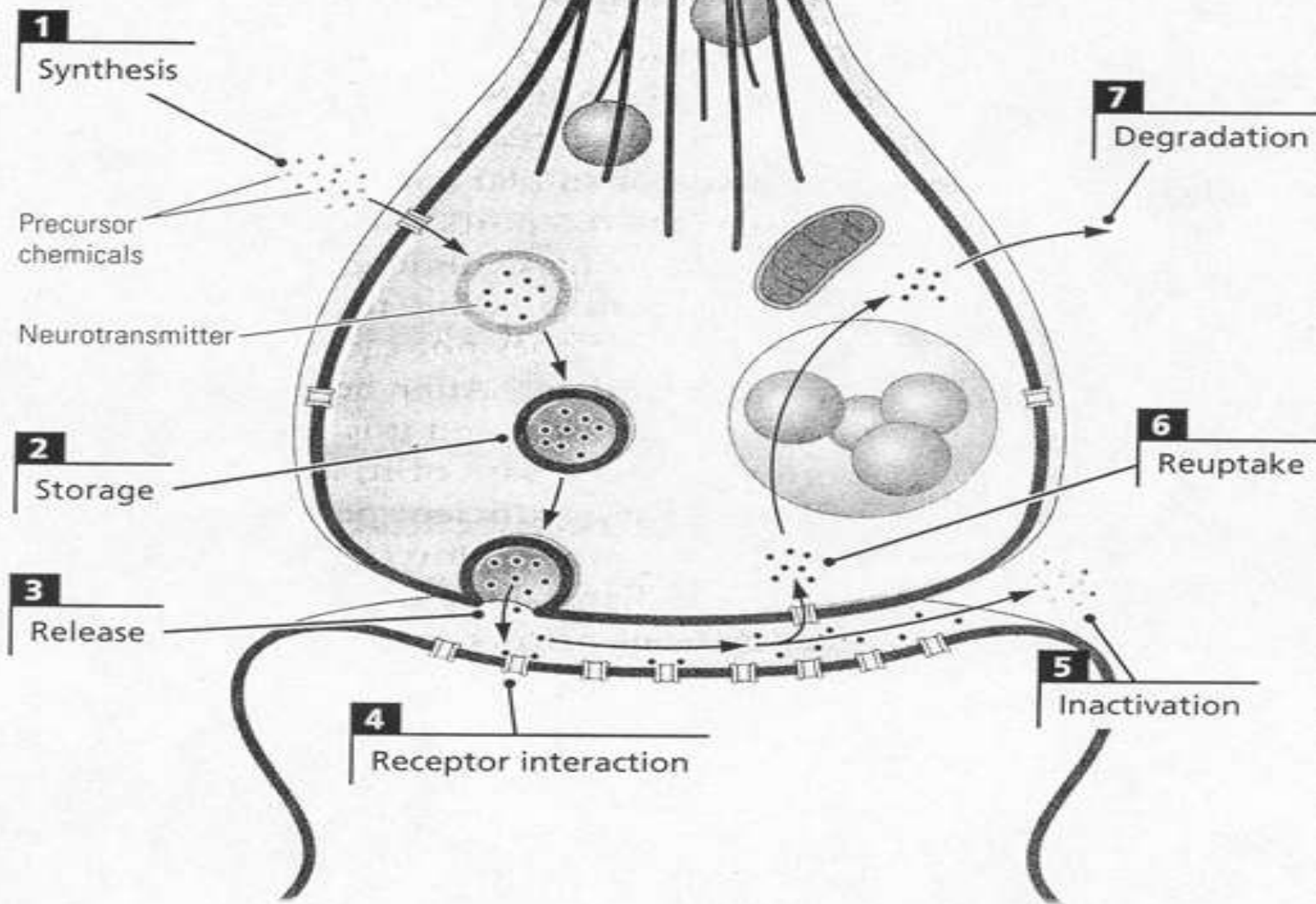

Místní recyklace vesikul je rychlejší než transport z Golgiho a. Spolupráce endosomu a vesikulu.

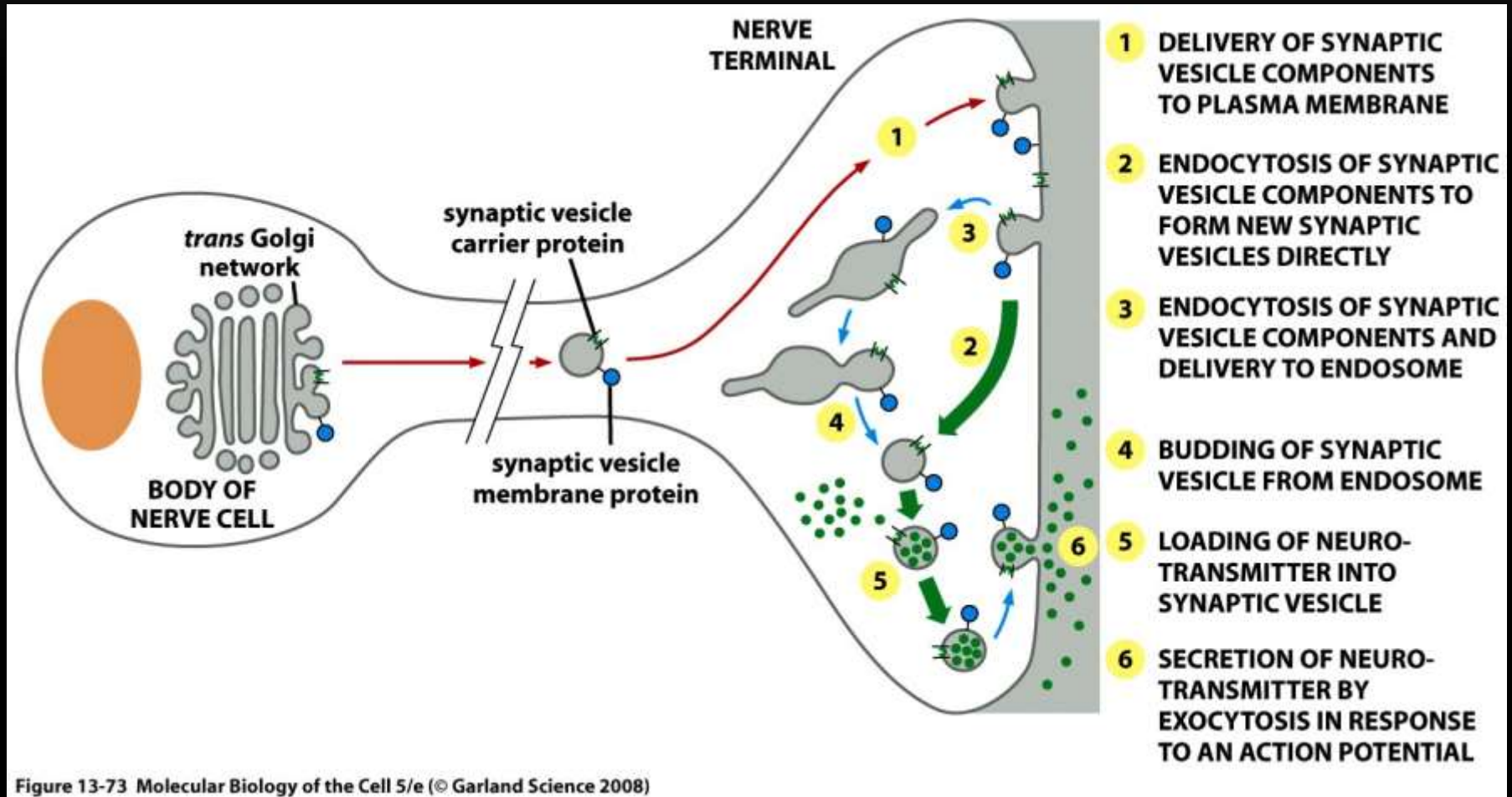

Figure 13-73 Molecular Biology of the Cell 5/e (© Garland Science 2008)

Synaptický vesikul:
Import transmitteru
na přenašči
hnaném H^+
gradientem.

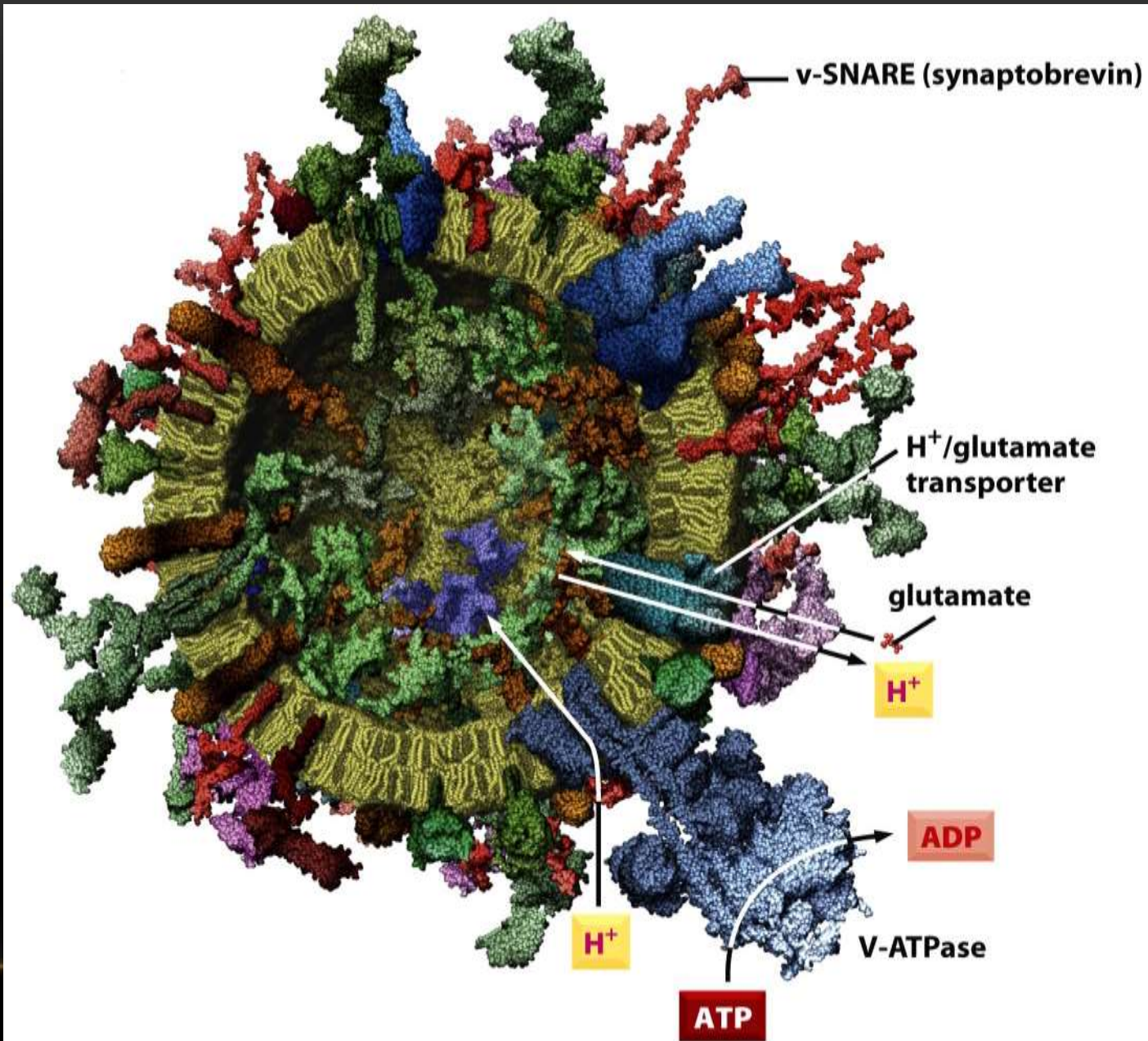
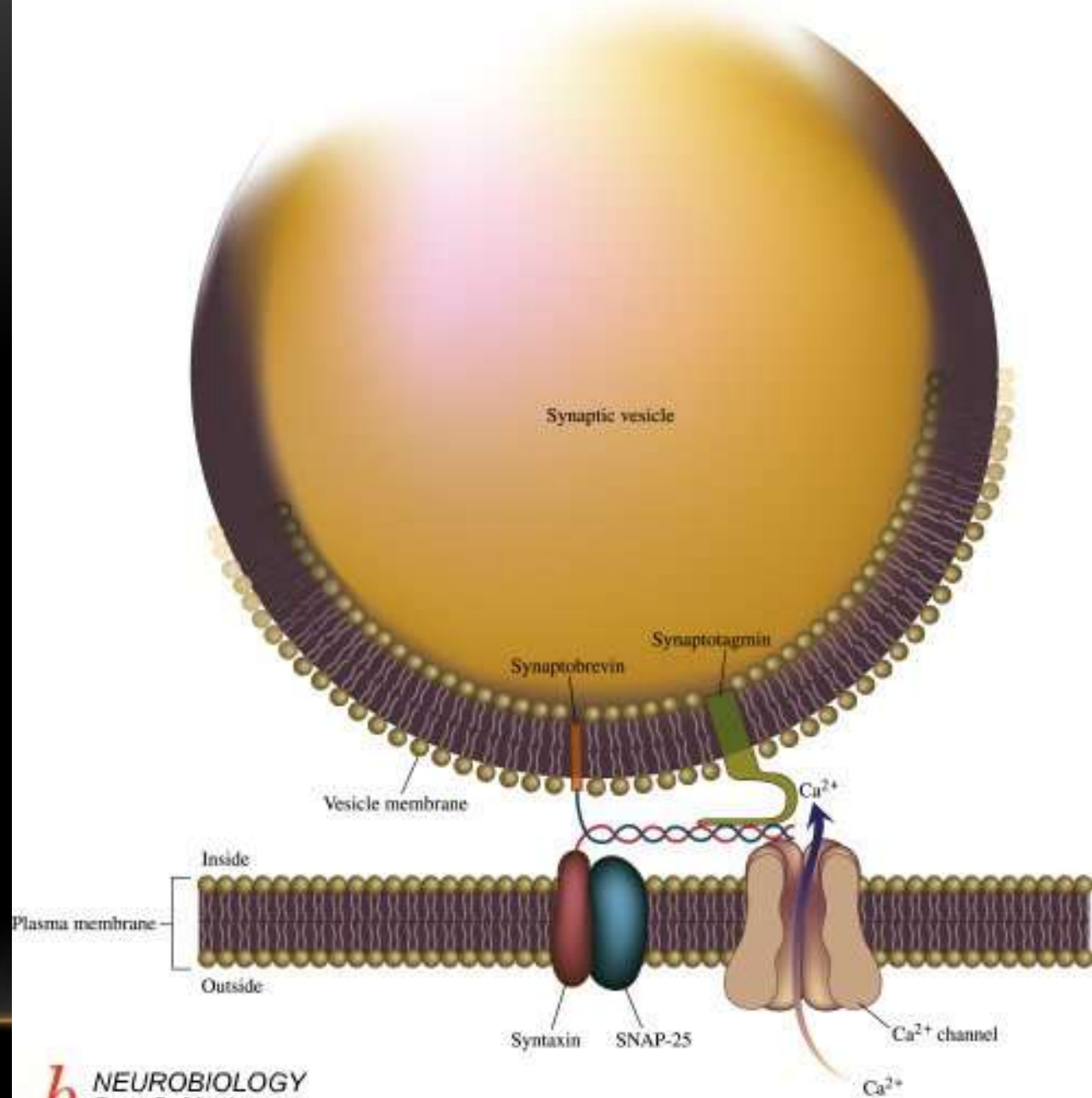

Figure 13-74 Molecular Biology of the Cell 5/e (© Garland Science 2008)

Ca se váže na synaptotagmin, Ten vyvolá interakci syntaxinu + SNAP 25 se synaptobrevinem = exocytóza.

Ca²⁺ dále aktivuje proteinkinázu II závislou na kalcium-kalmodulinu, která aktivuje v presynaptickém zakončení enzym synapsin, díky kterému se vezikuly znovu hromadí v aktivní zóně.



E. Ukončení působení transmiteru

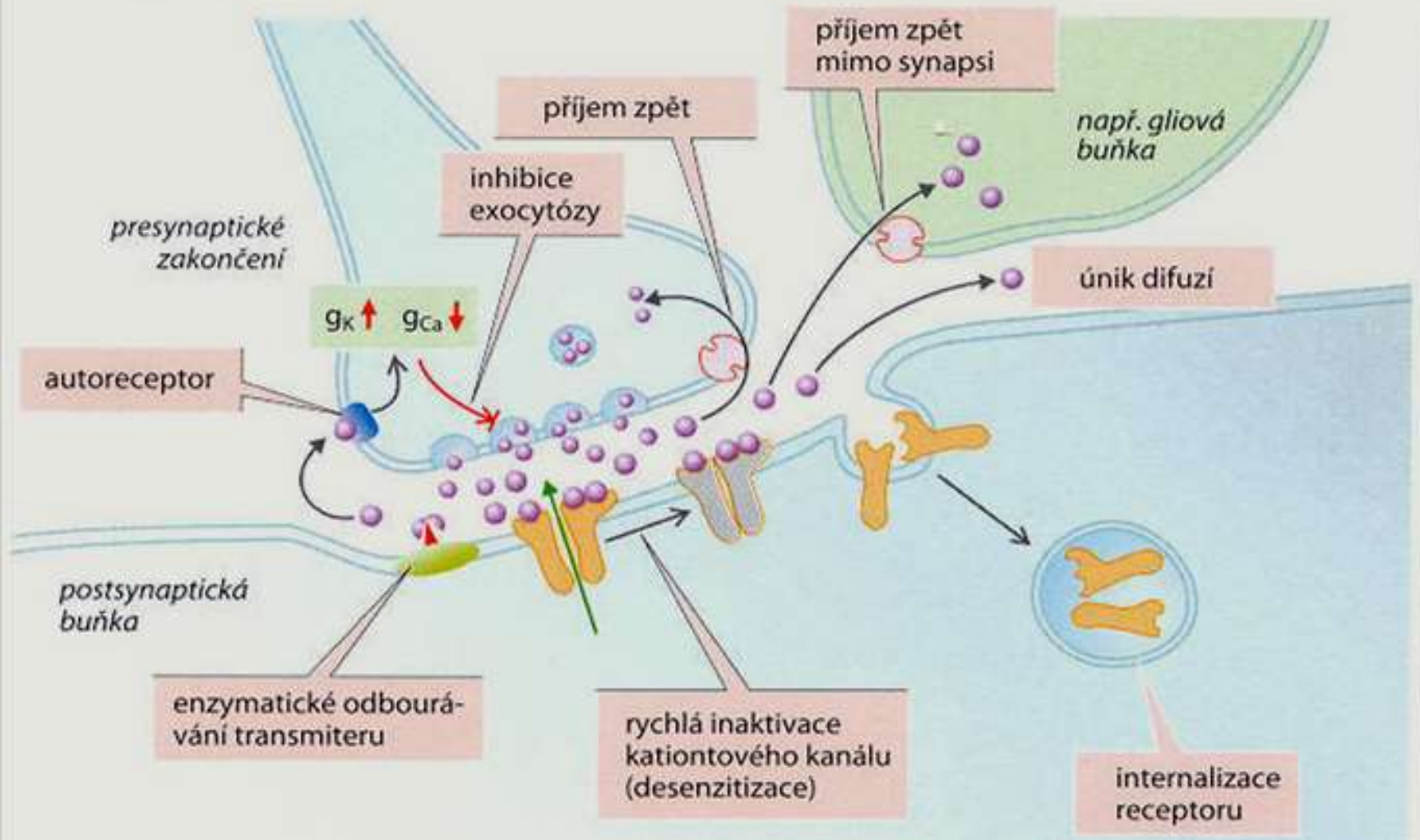

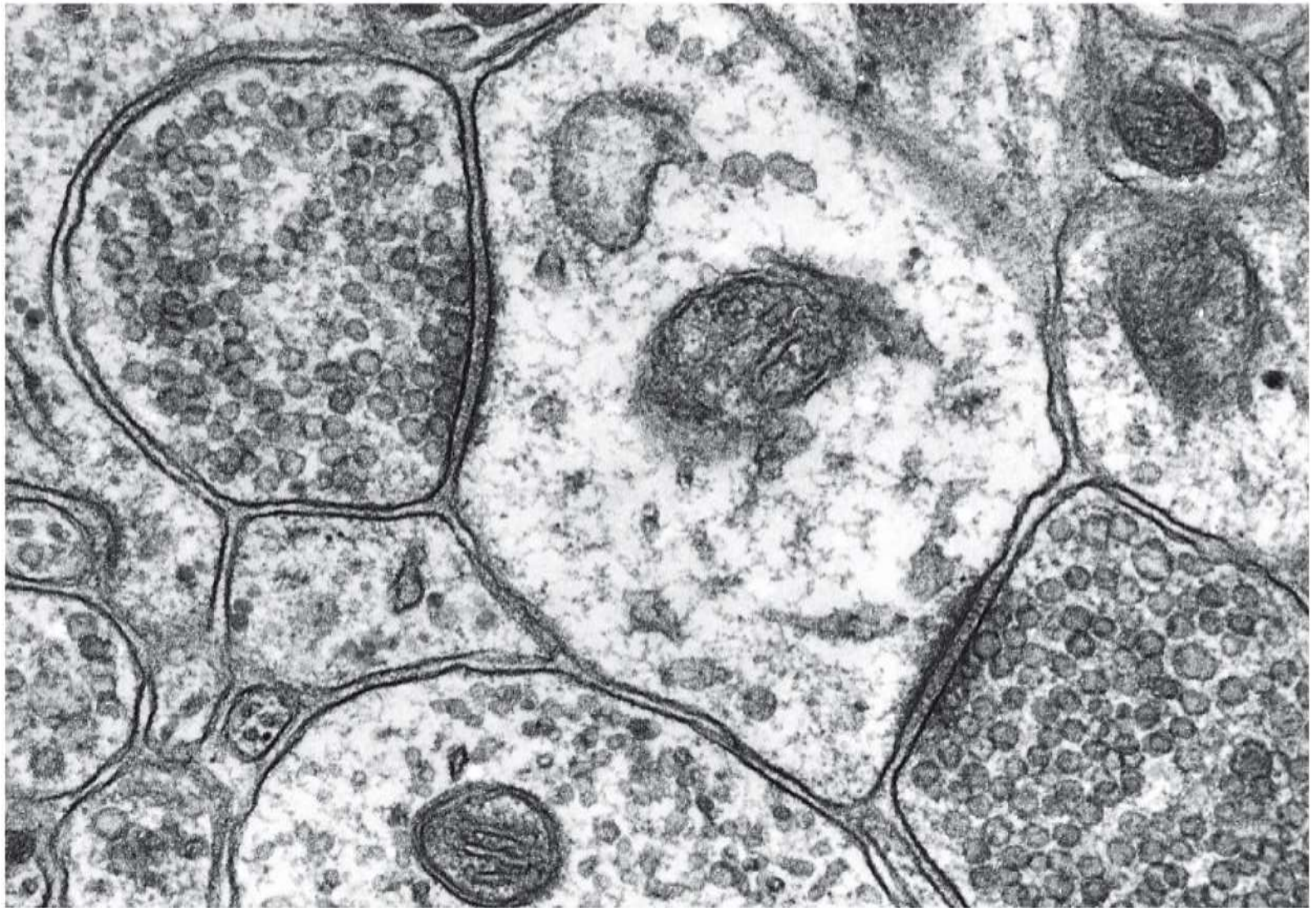

2 μm

Figure 19-22a Molecular Biology of the Cell 5/e (© Garland Science 2008)

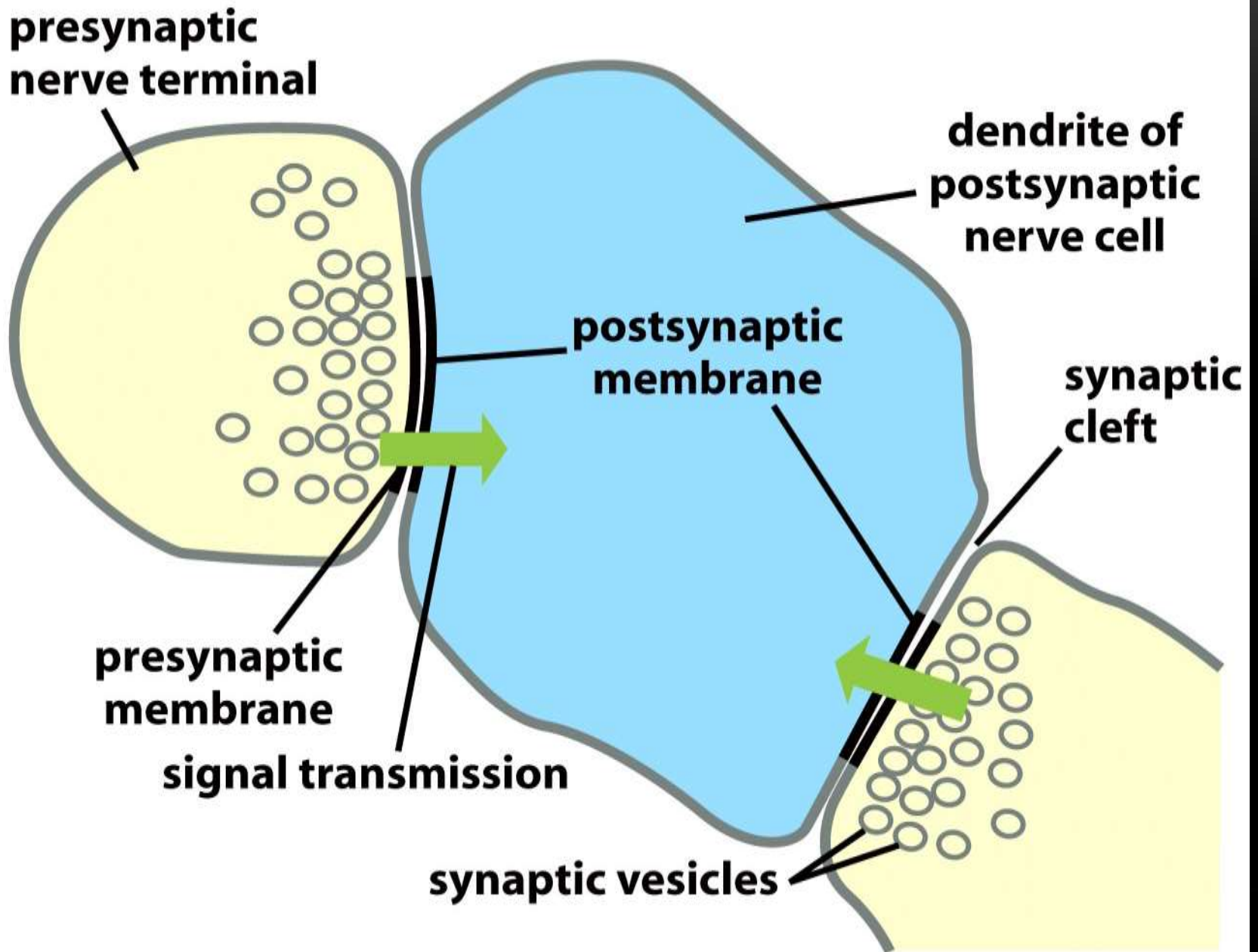

Figure 19-22b Molecular Biology of the Cell 5/e (© Garland Science 2008)

Buněčný spoj s mnoha kotvami napojenými na „lešení“

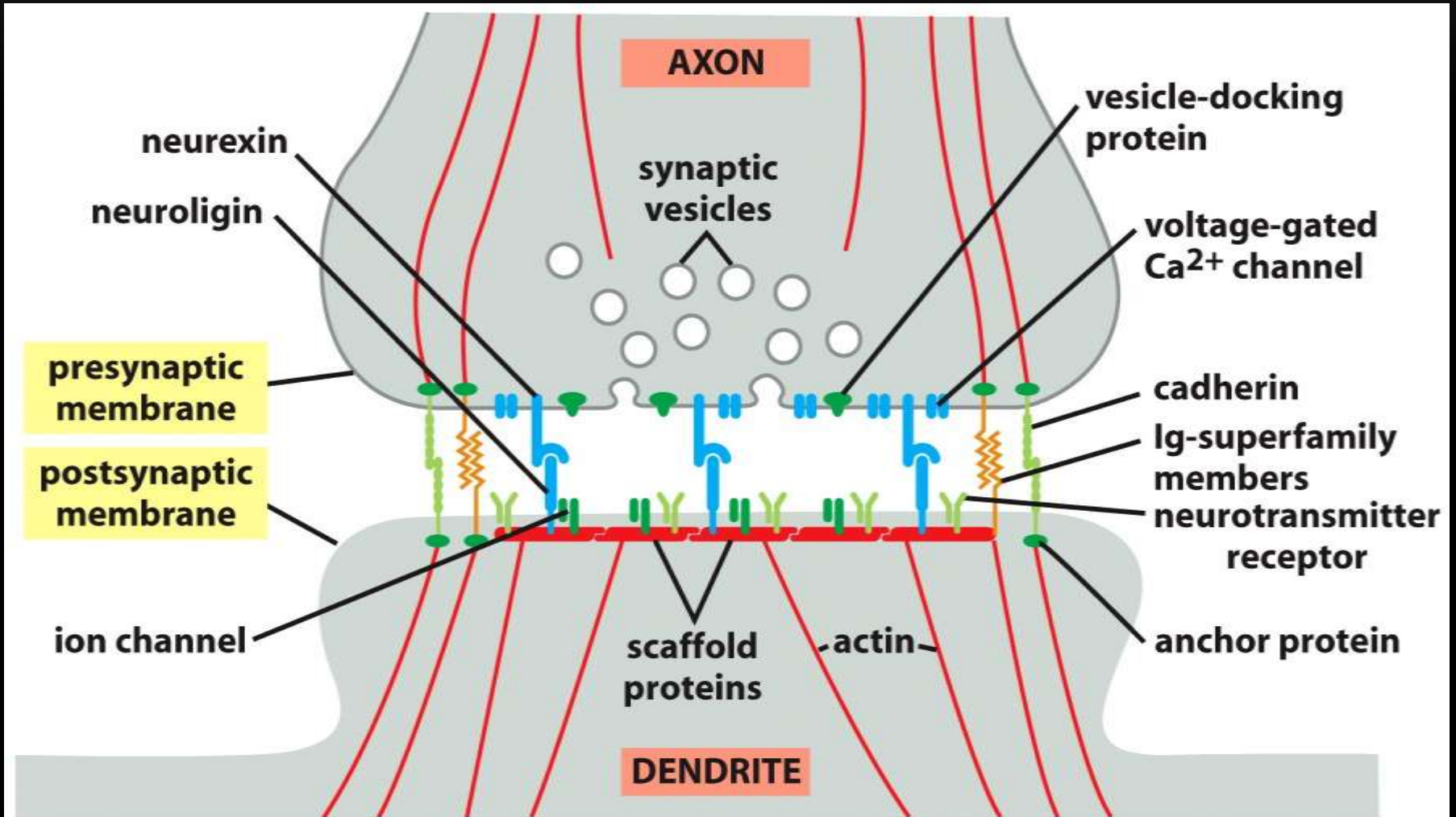

Figure 19-22c Molecular Biology of the Cell 5/e (© Garland Science 2008)

Postsynaptická strana - detail

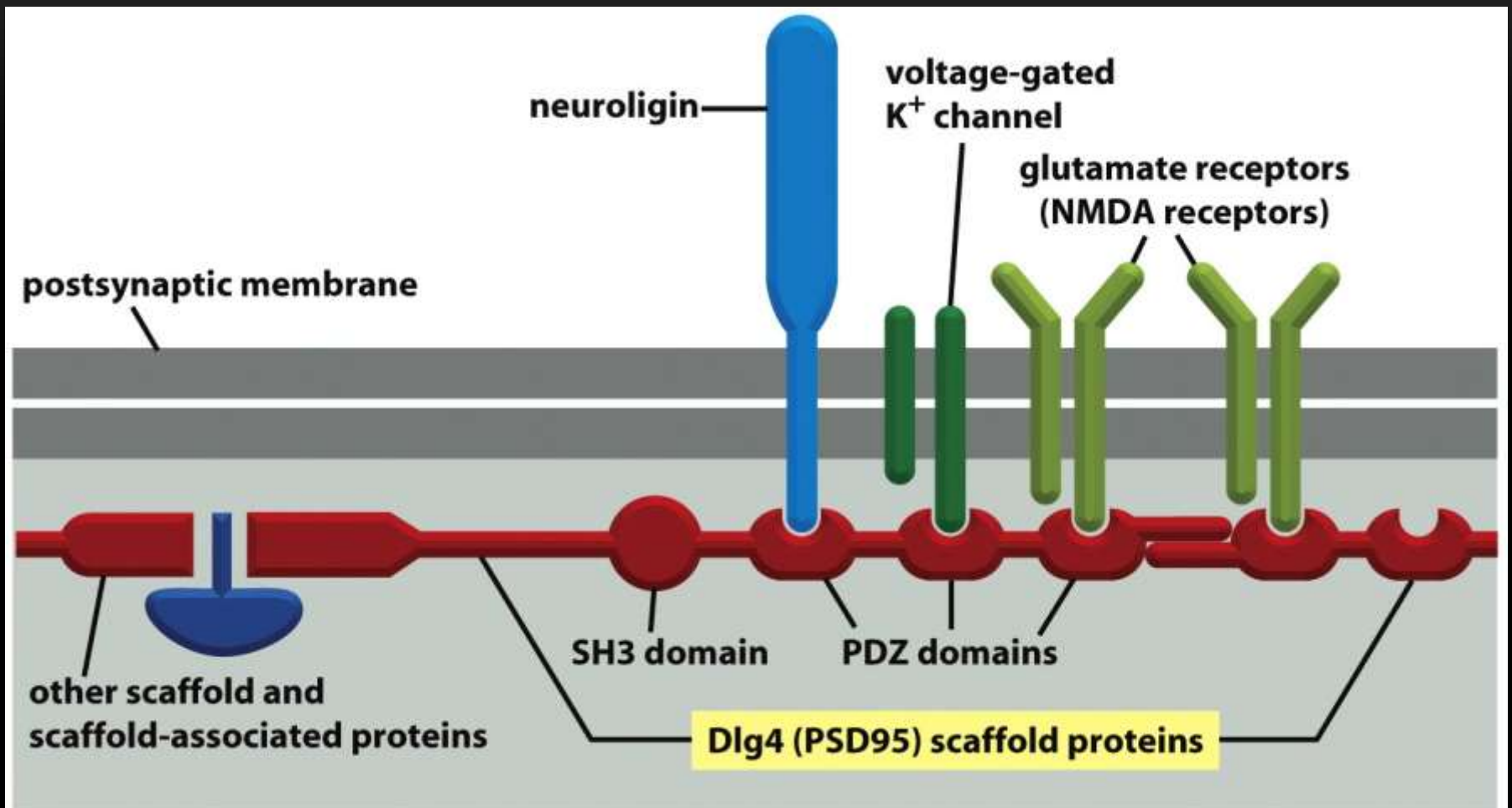

Figure 19-21 Molecular Biology of the Cell 5/e (© Garland Science 2008)

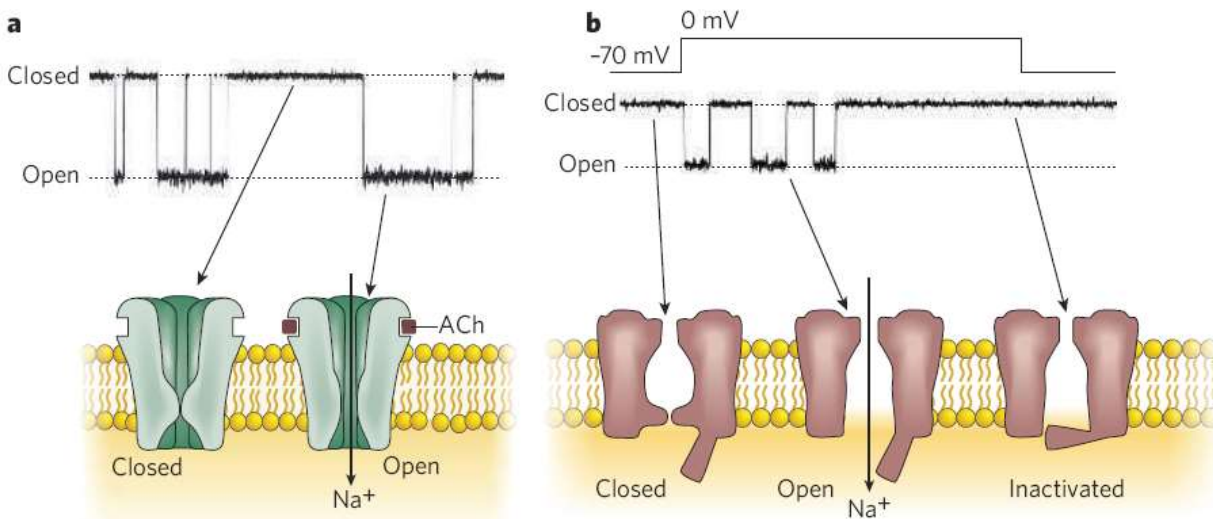
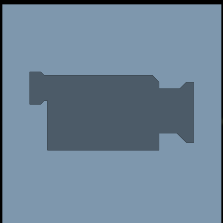
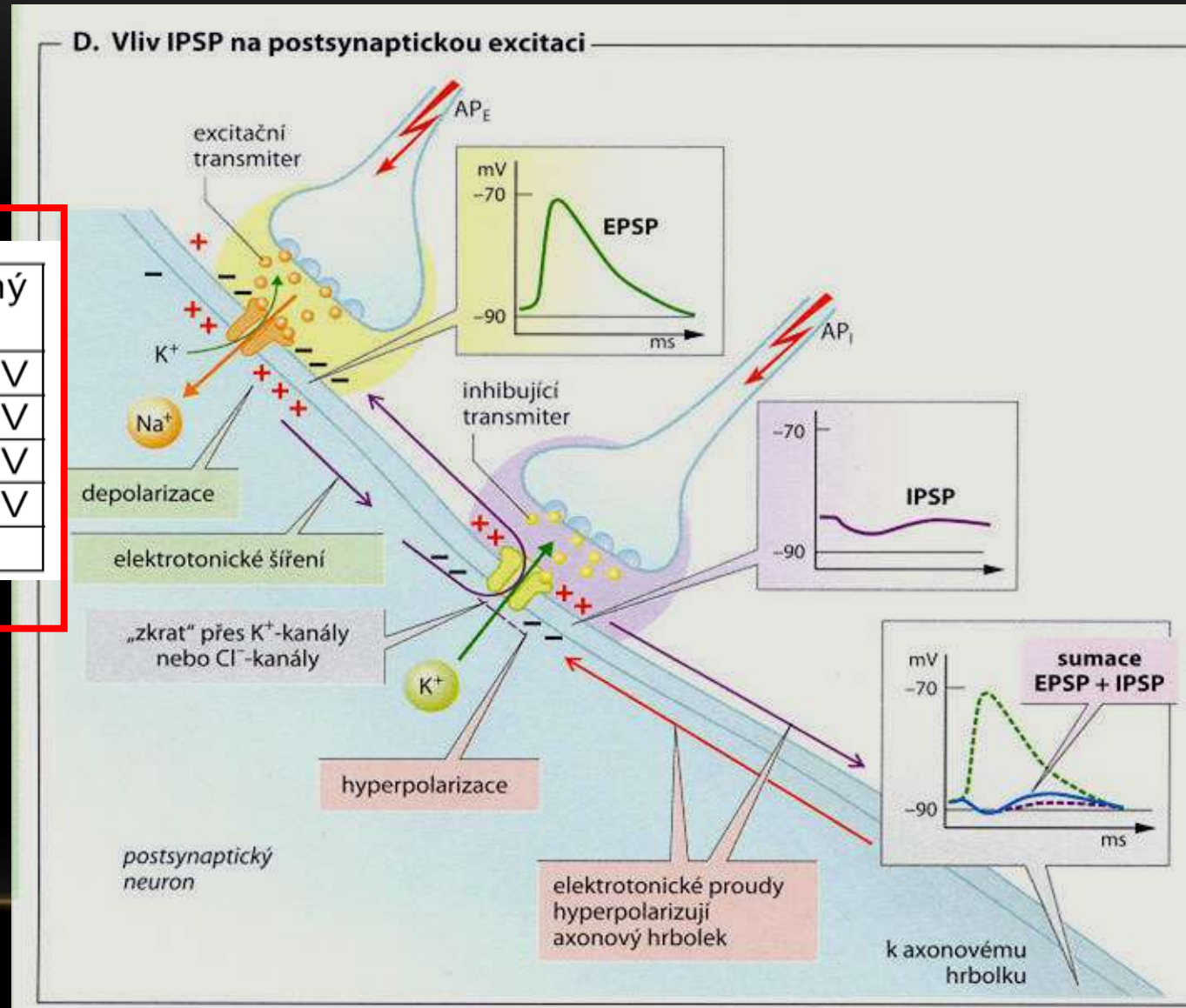

Figure 1 | Molecular nanoswitches. Schematics illustrating how ion channels open and close, with associated single-channel recordings. Opening and closing of the channel are random events, but the frequency with which they occur is influenced by, for example, ligand-binding (**a**) or transmembrane voltage (**b**). The transition rate between open and closed states is $<10 \mu\text{s}$. The flux rate through the pore when it is open is of the order of 10^7 ions per second; that mediated by the coupled exchangers is substantially smaller (see p. 484). Following opening, some voltage-gated channels enter an inactivated (non-conducting) state in which they are refractory to subsequent depolarization (**b**).

Patch-clamp záznam ionotropného receptoru.

Nemusí být jen excitační, jsou i inhibiční transmitery.

Iont	Rovnovážný potenciál
Na^+	+67 mV
K^+	-98 mV
Cl^-	-90 mV
volný Ca^{2+}	+129 mV
fixní aniont	



Parasympatikus na myokardu

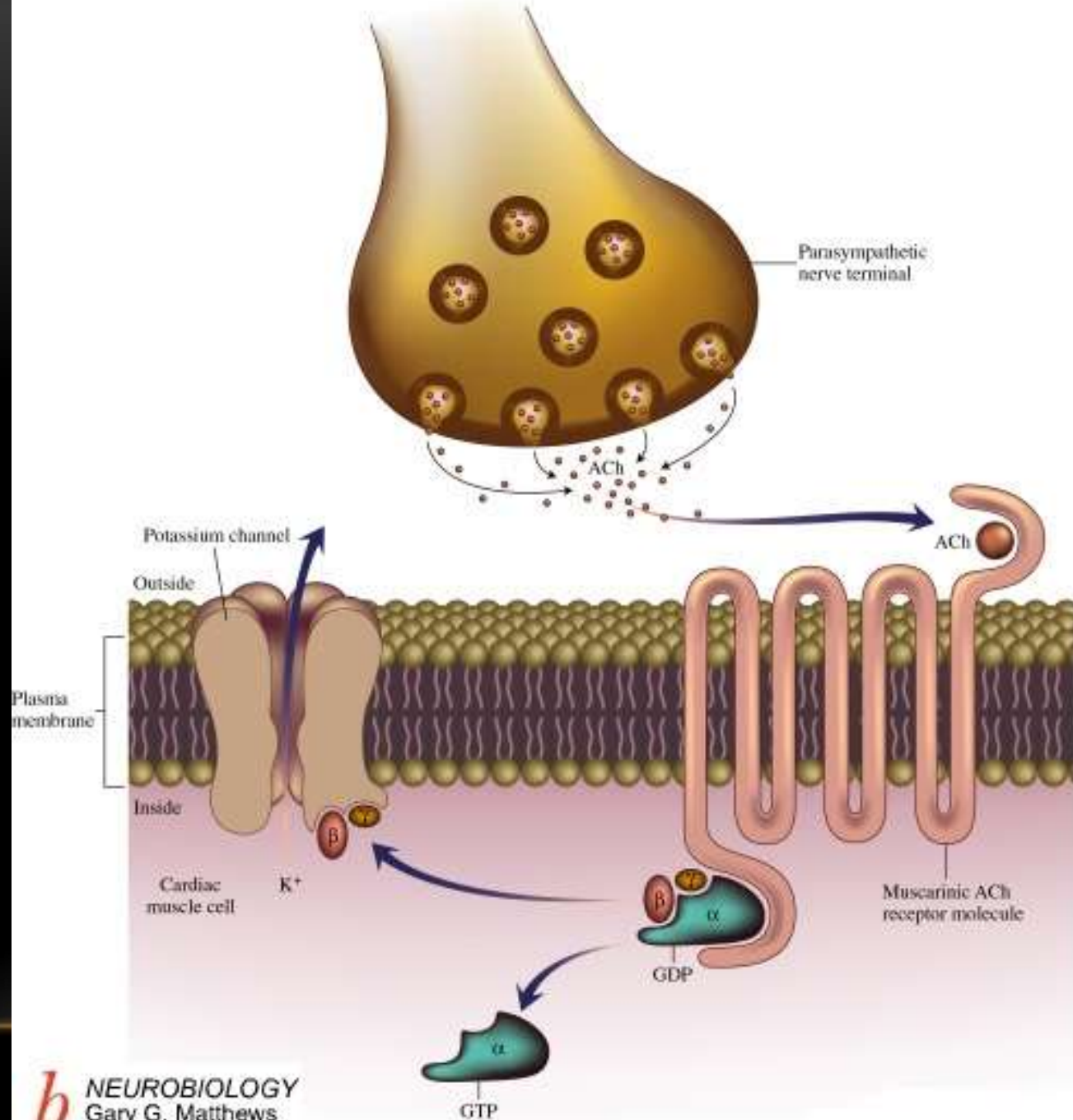

Sympatikus na myokardu

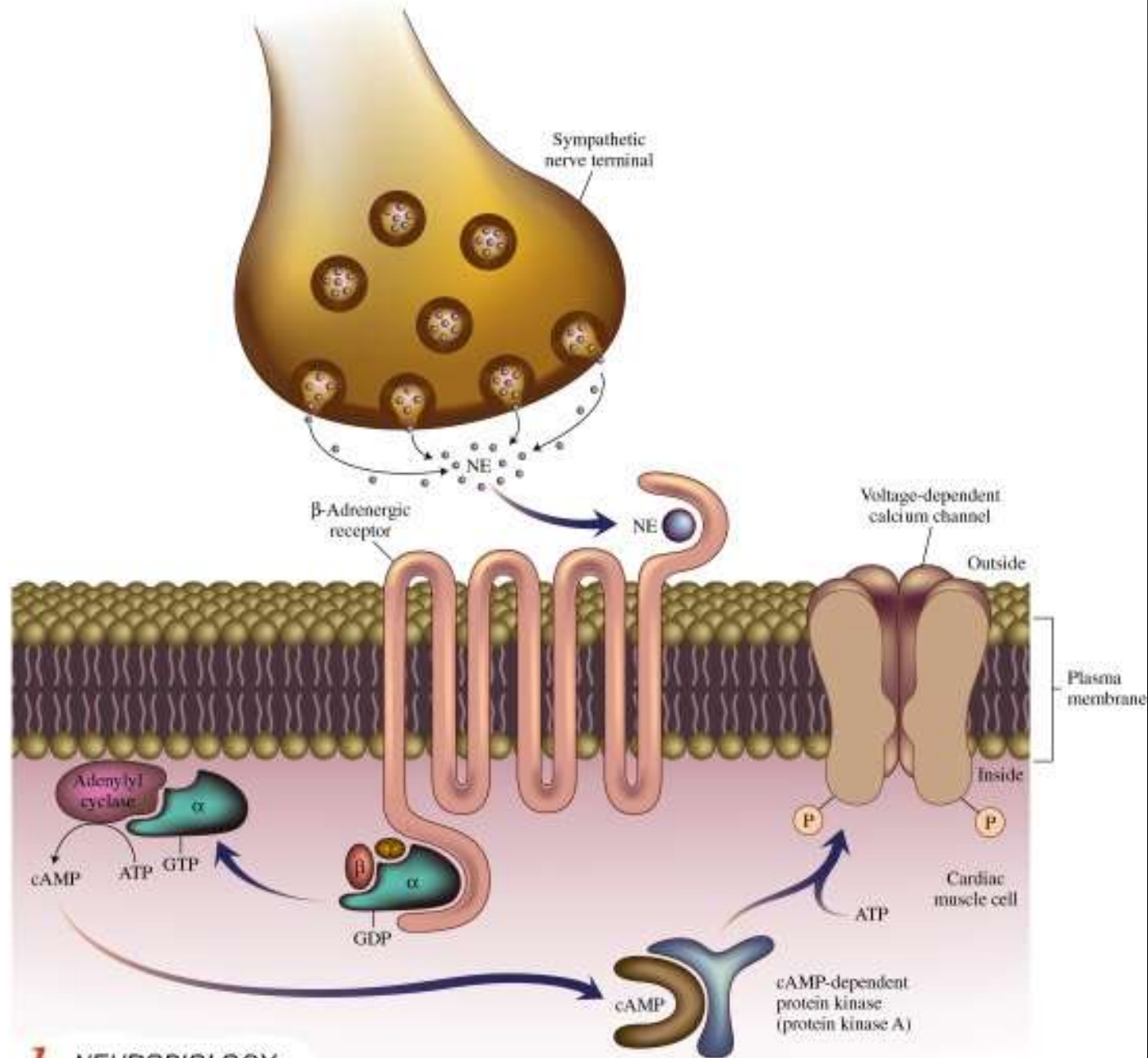

Odstupňovaný
potenciál

Vedení s
dekrementem

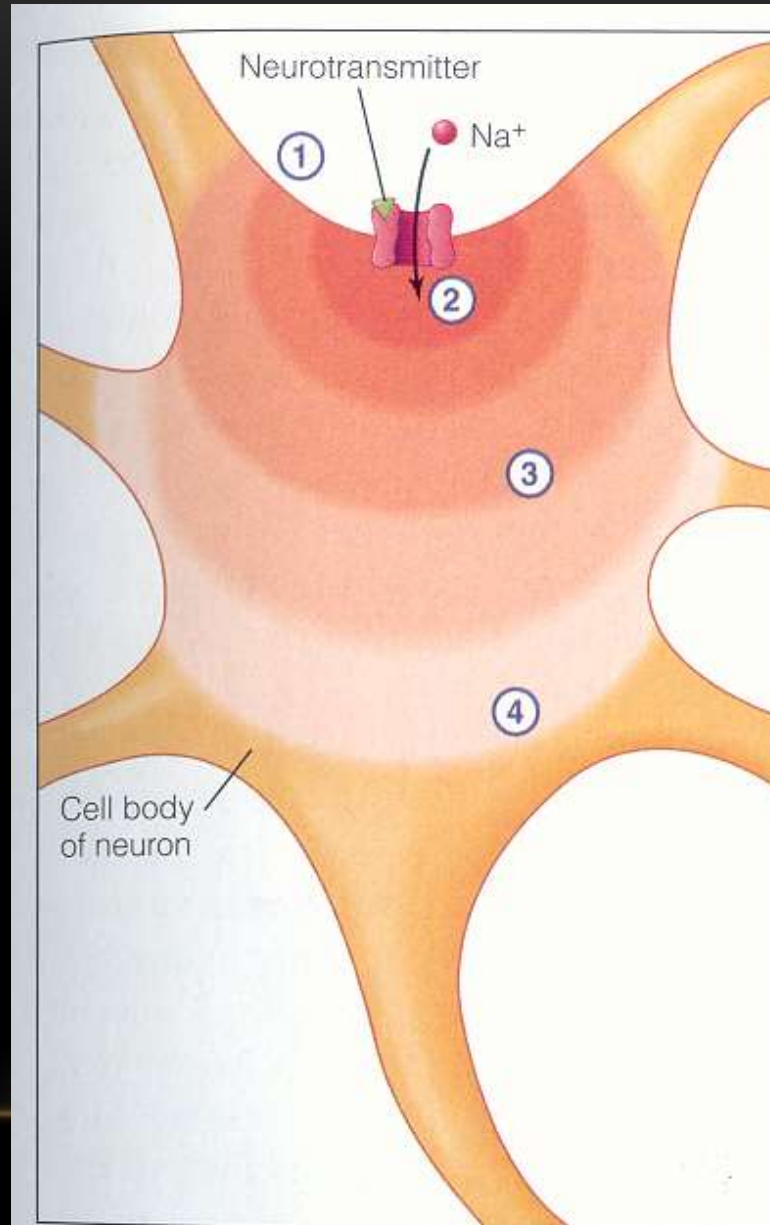

① Neurotransmitter binds to a ligand-gated Na^+ channel.

② Na^+ enters cell through the open channel.

③ Current spreads through the cell.

④ The strength of the signal decreases with distance.

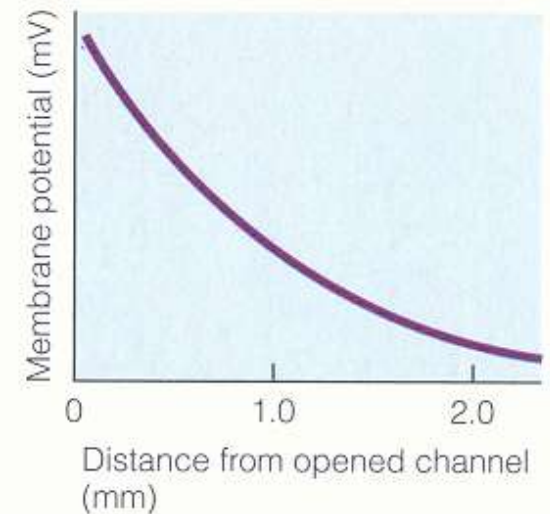

Prostorová a časová sumace

B. Prostorová sumace podráždění

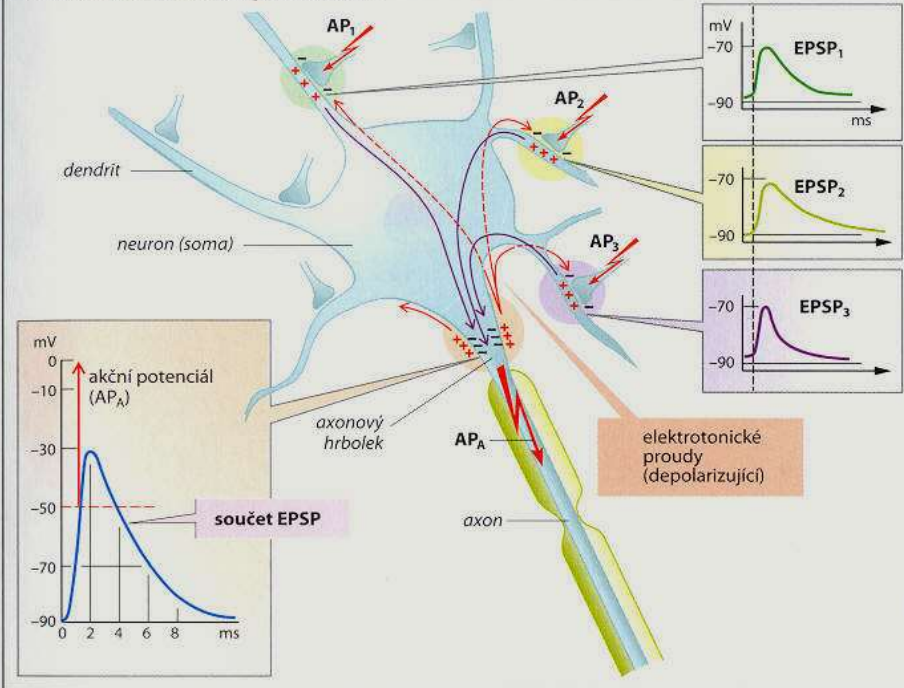

C. Časová sumace podráždění

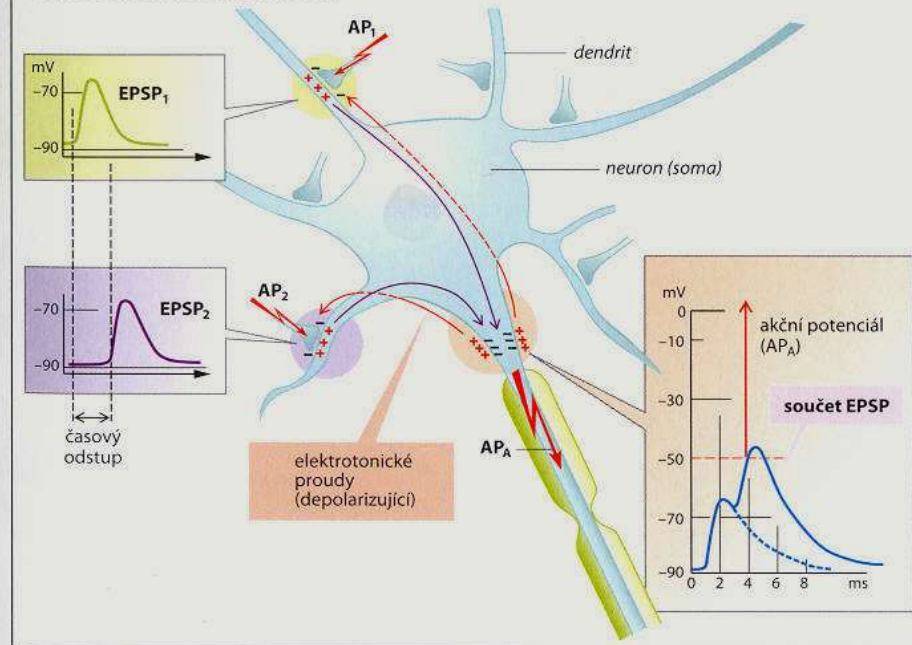

a Räumliche Summation

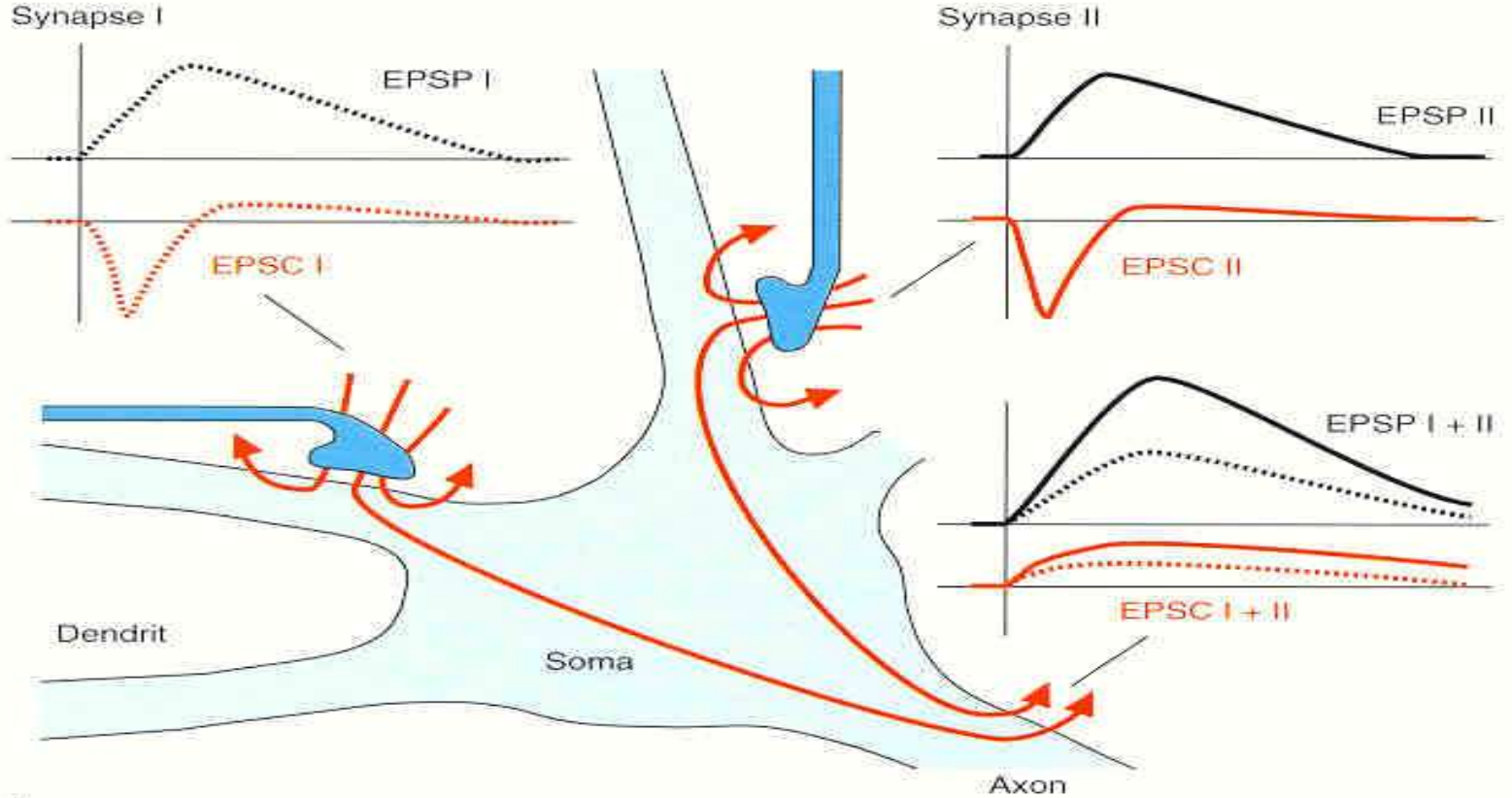

b Zeitliche Summation

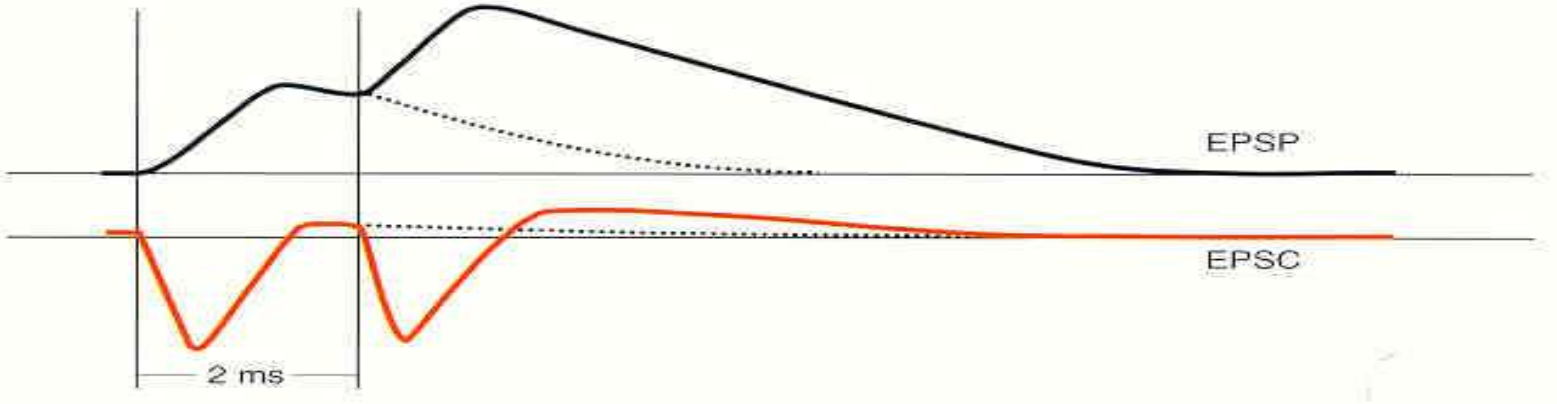

Srovnání dvou typů elektrické řeči.

Table 4-2 ■ Comparison of Graded Potentials and Action Potentials

Graded Potentials	Action Potentials
Graded potential change; magnitude varies with magnitude of triggering event	All-or-none membrane response; magnitude of triggering event coded in frequency rather than amplitude of action potentials
Decremental conduction; magnitude diminishes with distance from initial site	Propagated throughout membrane in undiminishing fashion
Passive spread to neighboring inactive areas of membrane	Self-regenerating in neighboring inactive areas of membrane
No refractory period	Refractory period
Can be summed	Summation impossible
Can be a depolarization or hyperpolarization	Always depolarization and reversal of charges
Triggered by a stimulus, by combination of neurotransmitter with receptor, or by spontaneous shifts in leak-pump cycle	Triggered by depolarization to threshold, usually through the spread of a graded potential
Occurs in specialized regions of membrane designed to respond to the triggering event	Occurs in regions of membrane with an abundance of voltage-gated Na^+ channels

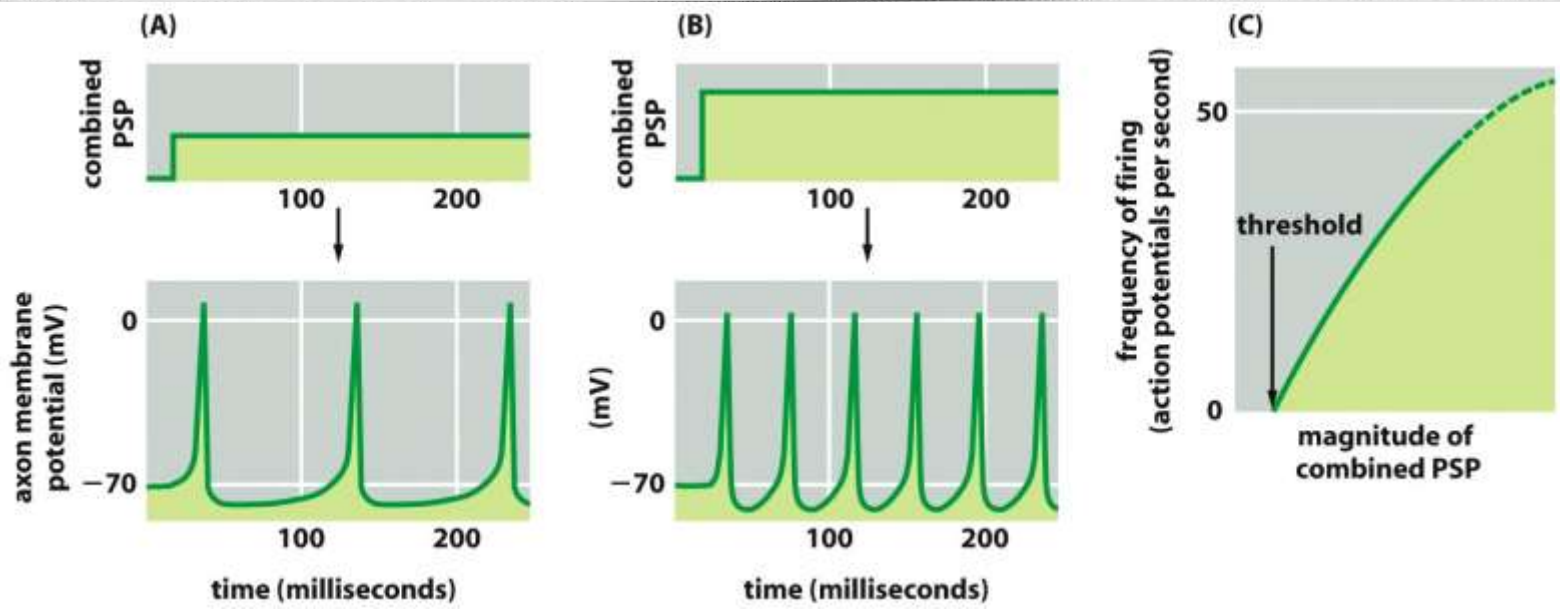

Na iniciálním segmentu se velikost depolarizace překódovává na frekvenci AP. Aby tuto speciální funkci axonový hrbolk plnil, musí tu být kromě Na kanálu citlivého na napětí ještě další 4 typy iontových kanálů: 3 selektivní pro K⁺ (zpožděné, rychle inaktivující a Ca-aktivované); a 1 typ selektivní pro Ca.

Zpožděné K⁺ vrací membránu ke K⁺ klidovému napětí – repolarizují po depolarizaci. Trvalý podnět tedy vyvolá trvalé „pálení“.

Aby se ale vyšší depolarizace převedla na vyšší f AP, musí tu být rychle inaktivující K⁺ kanály. Ty se také otevírají při depolarizaci a inaktivují se, ale úměrně k ní, takže zůstávají dlouho otevřené a snižují frekvenci AP u depolarizace těsně nad prahem, ale u větší depolarizace se inaktivují dříve, počet otevřených K kanálů je tedy nižší (tím méně se uplatňují) a frekvenci AP netlumí.

Ca a Ca dependentní K kanály se uplatňují při adaptaci – při reakci axonu na trvalou depolarizaci. Jak je membrána dlouhodobě depolarizována, roste počet Ca iontů vniklých přes napětově sensitivní Ca kanály. To vede k otevření K kanálů a tak se membrána hyperpolarizuje. Frekvence AP při trvalé nepřerušované stimulaci klesá. Reaguje tedy lépe na změnu než na trvalý podnět.

Analýza tisíců vstupů.
Větvení na tisíce výstupů.

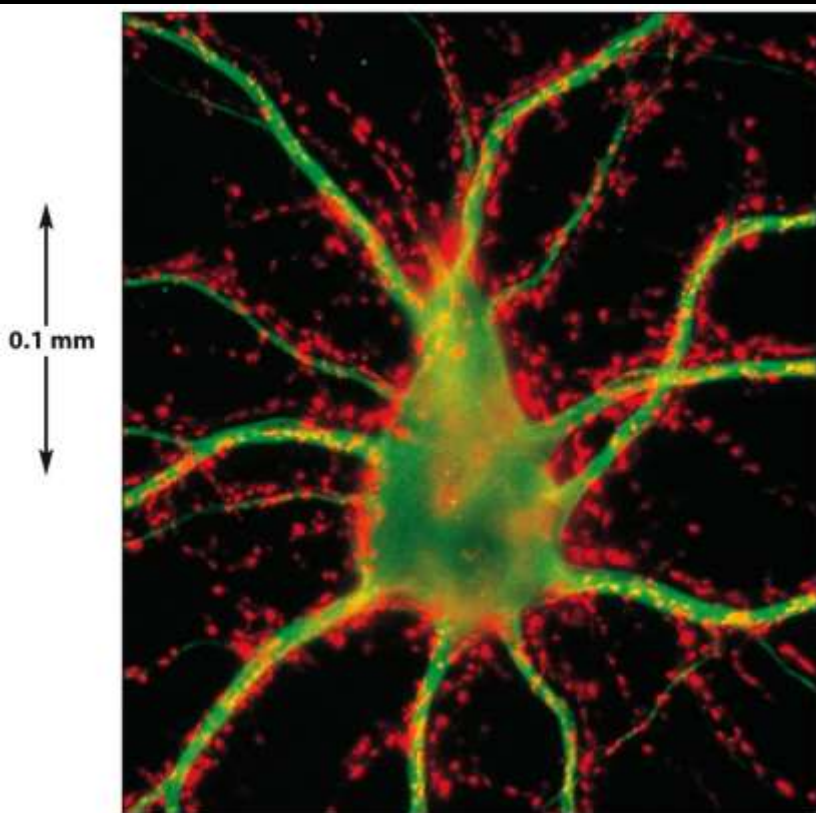

Figure 11-40b Molecular Biology of the Cell 5/e (© Garland Science 2008)

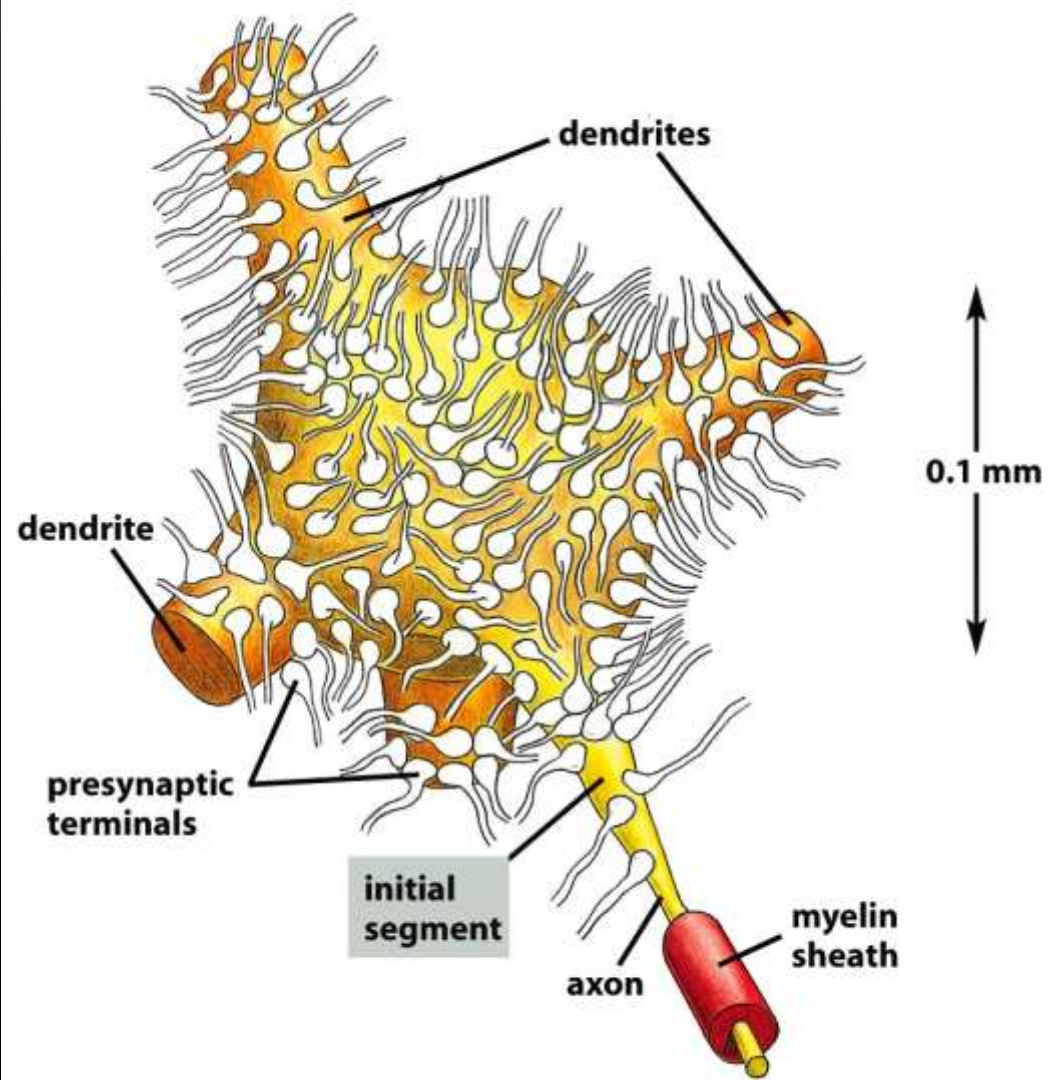
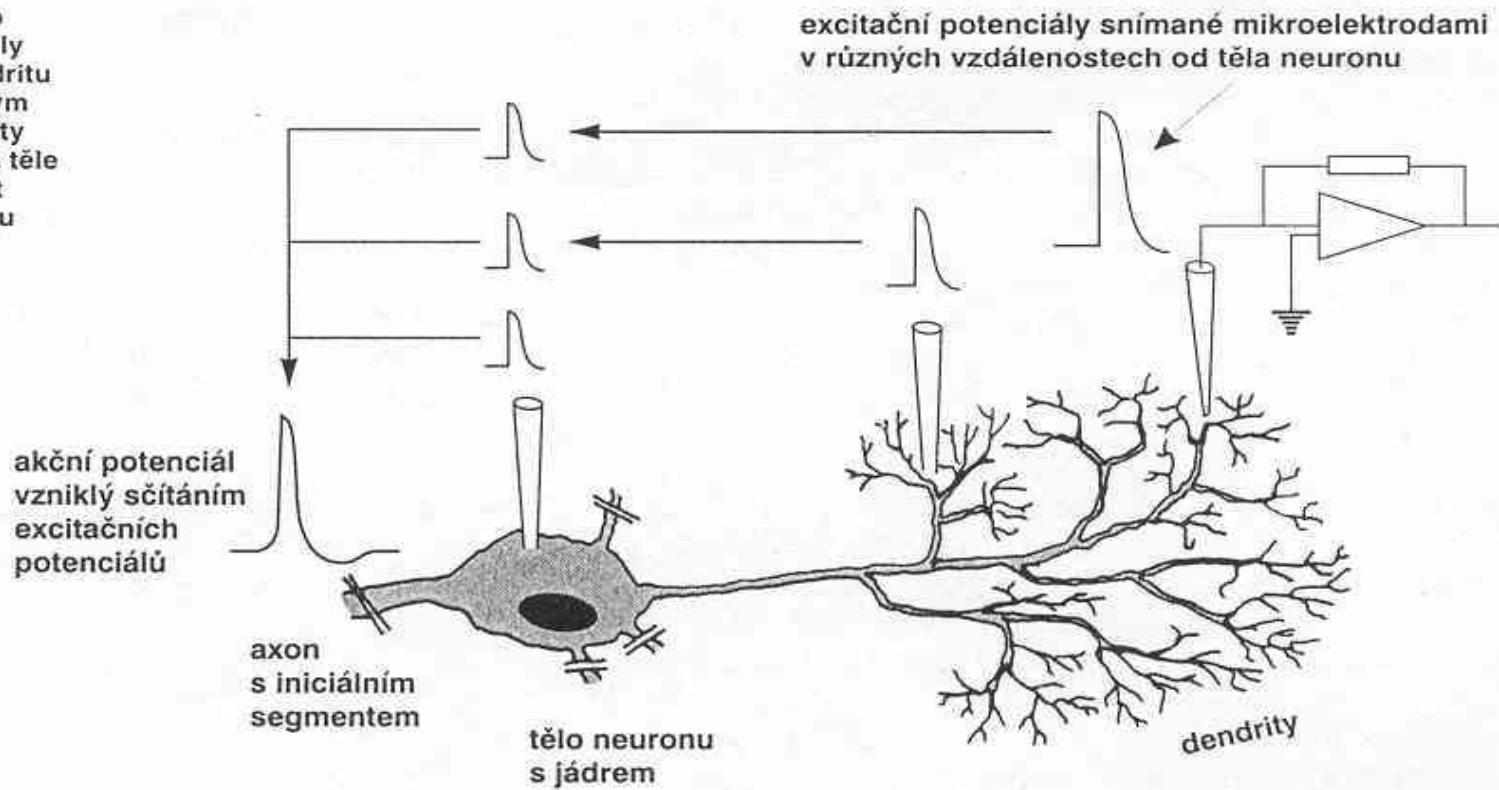
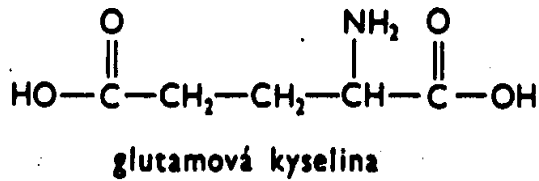
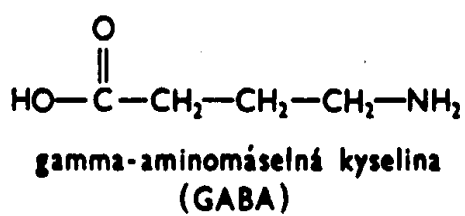

Figure 11-40a Molecular Biology of the Cell 5/e (© Garland Science 2008)

Vzdálenější vstupy ale nejsou diskriminovány! Synaptické stupňování a „volání nazpět“

1. Schéma pokusu Mageeho a Cooka. Excitační potenciály vyvolané ostříkováním dendritu vysokoosmotickým cukerným roztokem se během své cesty k tělu neuronu zmenšují. Na těle neuronu už je jejich velikost stejná, ač se při svém vzniku amplitudou lišily. Sčítáním potenciálů může vzniknout akční potenciál.





Excitační x inhibiční

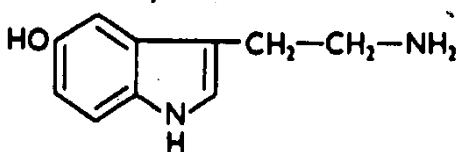
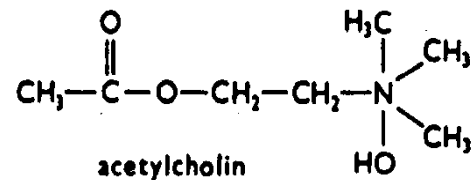
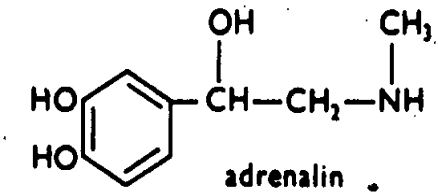
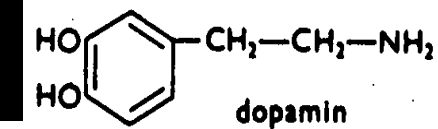

transmitter	typy receptorů	druh receptoru	účinek				druhý posel	
			Na ⁺	K ⁺	Ca ²⁺	Cl ⁻	cAMP	IP ₃ /DAG
acetylcholin	nikotinový muskarinový: M1, M2, M3	●	↑	↑	↑			↑
ADH (= vazopresin)	V1 V2	●					↑	↑
CCK (= cholecystokinin)	CCK _{A-B}	●						↑
dopamin	D1, D5 D2	●		↑	↓		↓	↑
GABA (= γ-aminomáselná kys.)	GABA _A , GABA _C GABA _B	●		↑	↓	↑	↓	
glutamát (aspartát)	AMPA kainat NMDA m-GLU	●	↑	↑	↑		↓	↑
glycin	-	●				↑		
histamin	H ₁ H ₂	●					↑	↑
neurotenzin	-	●					↓	↑
noradrenalin, adrenalin	α ₁ (A-D) α ₂ (A-C) β ₁₋₃	●		↑	↓		↓	↑
NPY (= neuropeptid Y)	Y1-2	●		↑	↓		↓	
opioidní peptidy	μ, δ, κ	●		↑	↓		↓	
oxytocin	-	●						↑
puriny	P ₁ : A ₁ A _{2a} P _{2X} P _{2Y}	●		↑	↓		↓	↑
serotonin (= 5-hydroxytryptamin)	5-HT ₁ 5-HT ₂ 5-HT ₃ 5-HT ₄₋₇	●	↑	↑	↓		↓	↑
somatostatin (= SIH)	SRIF	●		↑	↓		↓	
tachykinin	NK1-3	●						↑

- aminokyseliny
- katecholaminy
- peptidy
- ostatní



Tab. 2.7 a 2.8 Synaptický přenos III a IV

Eric Kandel sumarizoval výsledky své práce na receptorech:

- Způsob účinku synapse není determinován transmitterem, ale vlastnostmi receptoru na postsynaptické buňce.
- Receptory na postsynaptických (přijímacích) buňkách jediného presynaptického neuronu mohou být farmakologicky odlišné a mohou řídit různé iontové kanály
- Jediná přijímací buňka může mít více než jediný druh receptoru pro daný transmitter, přičemž každý receptor může řídit jiný mechanismus iontové propustnosti.

Stejný
mediátor, ale
různé dráhy a
opačný účinek.

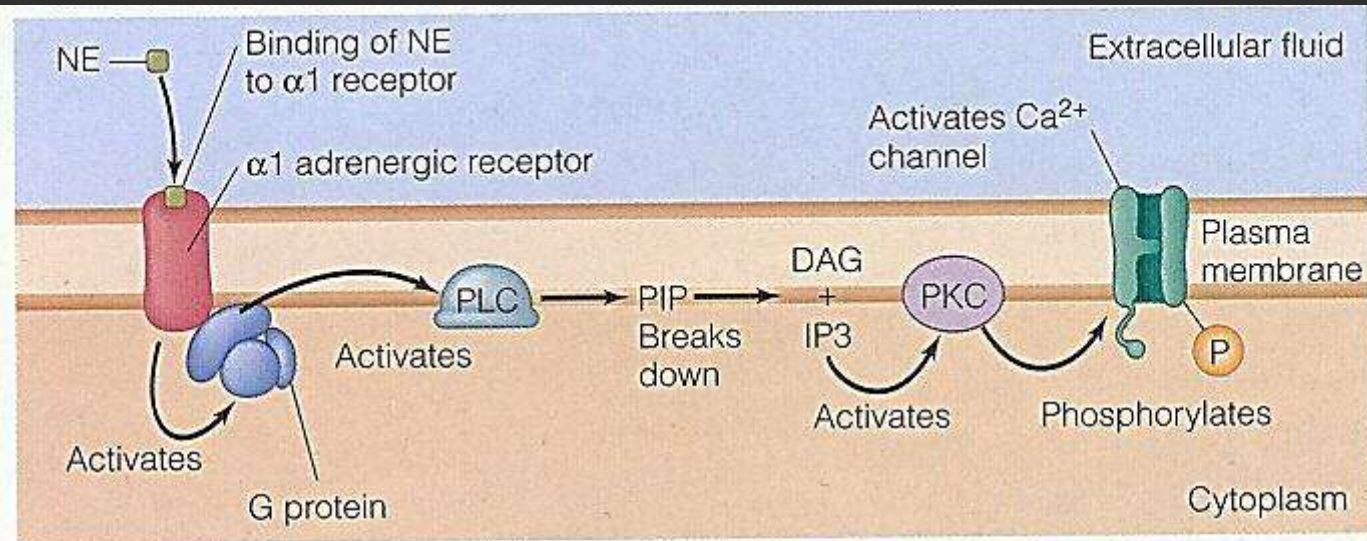

(a) Binding of NE to α_1 adrenergic receptors

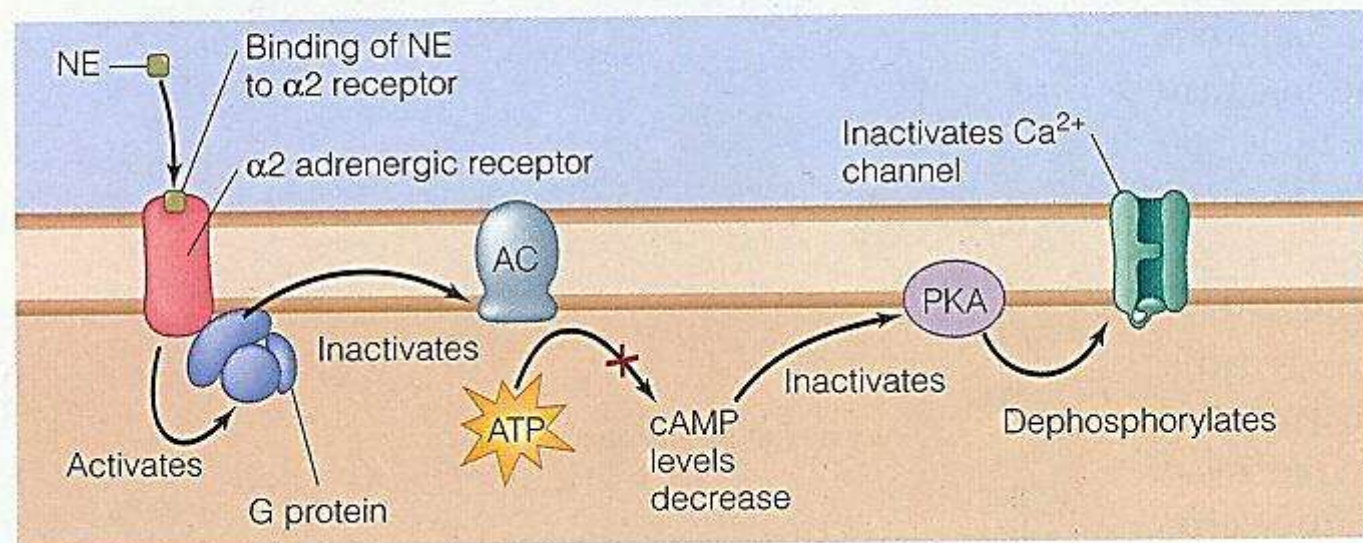

(b) Binding of NE to α_2 adrenergic receptors

Mimosynaptický přenos (presynaptická inhibice/potenciace)

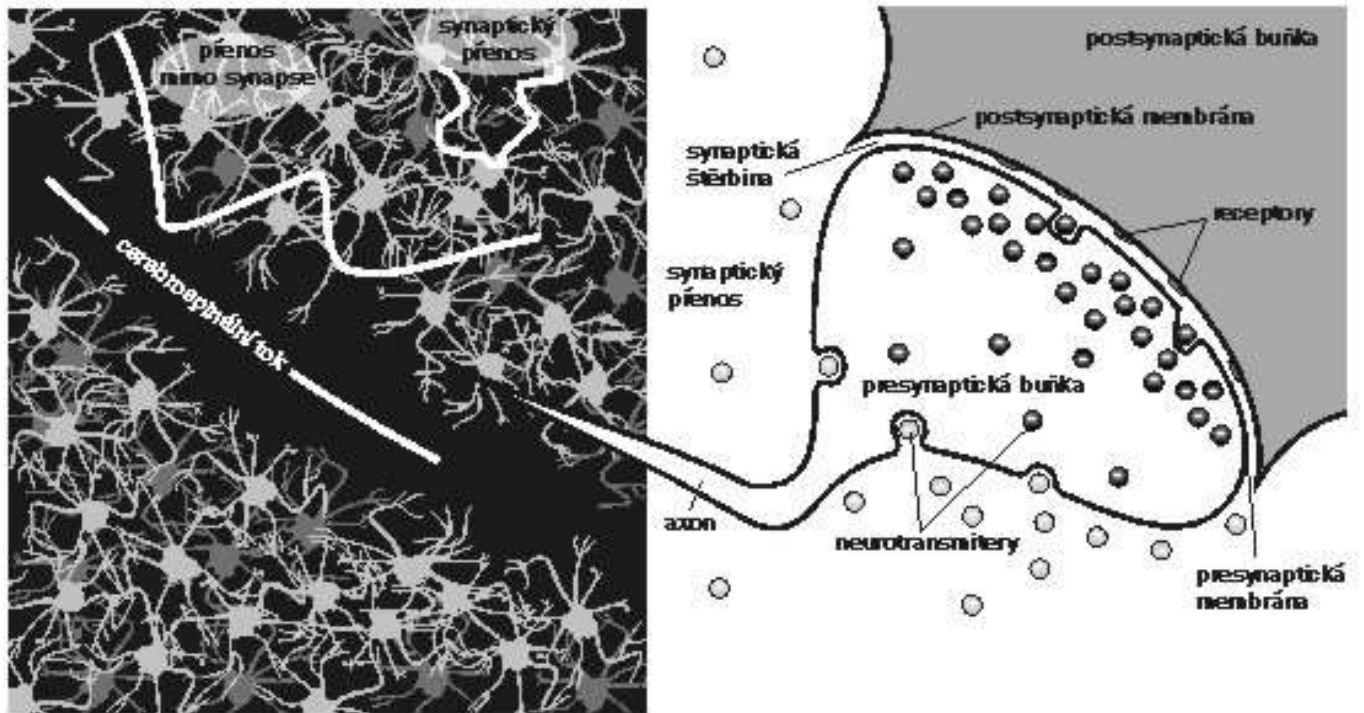

Mozek lze pokládat za žlázu s vnitřní sekrecí, která si své hormony produkuje sama. Pro rychlé procesy zajišťující jednotlivé funkce užívá synaptický přenos, kdežto pro celkové nastavení úrovně aktivity mimosynaptický. A mimosynaptický přenos je dost podobný způsobu, jímž se k svým cílům dostávají hormony. Rozdíl je jen v tom, že hormony se dopravují cévami v krevním proudu, kdežto neurotransmitery plují mozem v mozkomíšním moku.

Klasické transmitters

a

Neuroaktivní peptidy – neuromodulátory, kotransmitters

Table 4–4 ■ Comparison of Classical Neurotransmitters and Neuropeptides

Characteristic	Classical Neurotransmitters	Neuropeptides
Size	Small; one amino acid or similar chemical	Large: 2 to 40 amino acids in length
Site of synthesis	Cytosol of synaptic knob	Endoplasmic reticulum and Golgi complex in cell body; travel to synaptic knob by axonal transport
Site of storage	In small synaptic vesicles in axon terminal	In large dense-core vesicles in axon terminal
Site of release	Axon terminal	Axon terminal; may be cosecreted with neurotransmitter
Speed and duration of action	Rapid, brief response	Slow, prolonged response
Site of action	Subsynaptic membrane of postsynaptic cell	Nonsynaptic sites on either presynaptic or postsynaptic cells at much lower concentrations than classical neurotransmitters
Effect	Usually alter potential of postsynaptic cell by opening specific ion channels	Usually enhance or suppress synaptic effectiveness by long-term changes in neurotransmitter synthesis or postsynaptic receptor sites

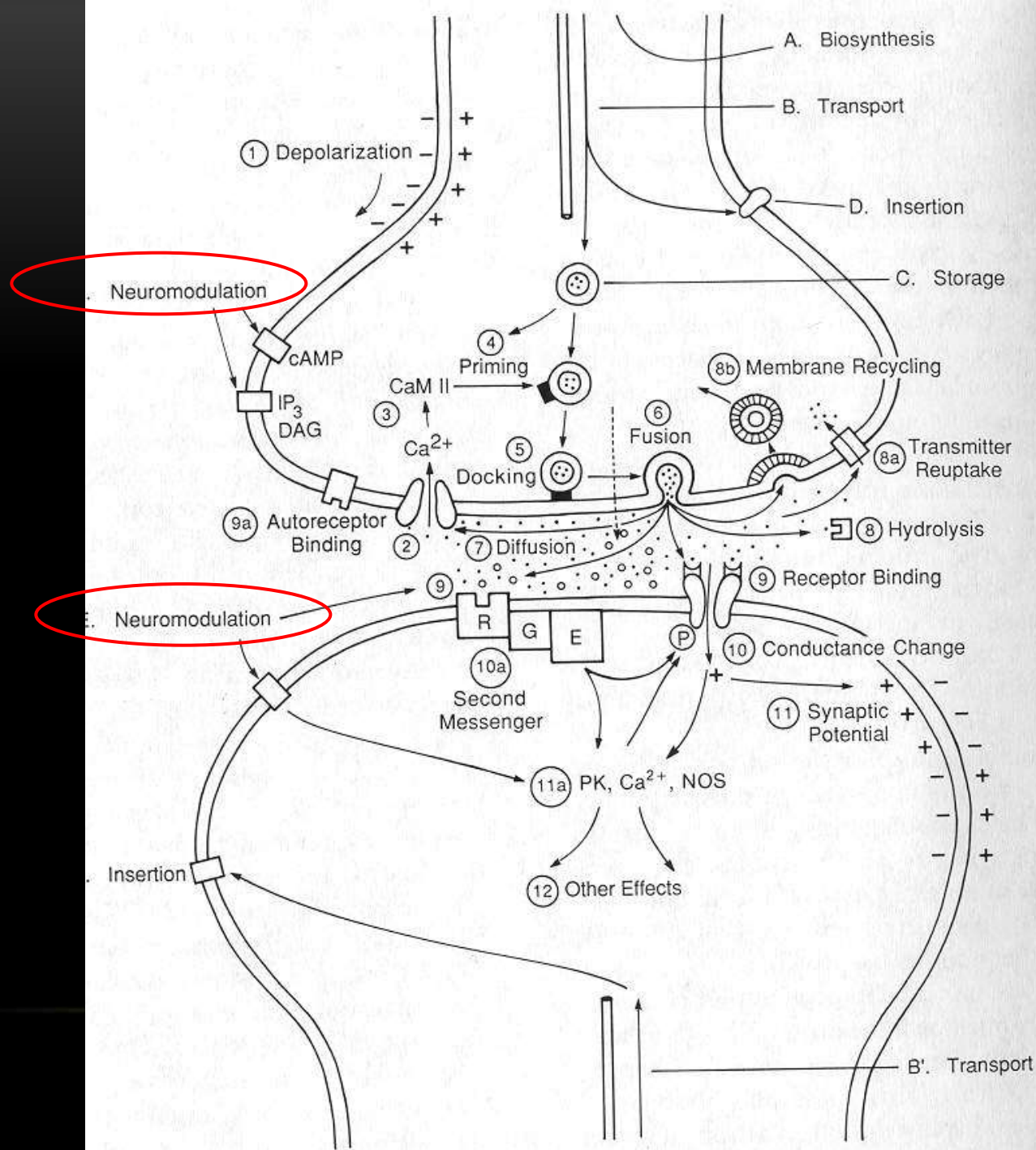

Receptory nejen na dendritech a těle:
Presynaptická synapse

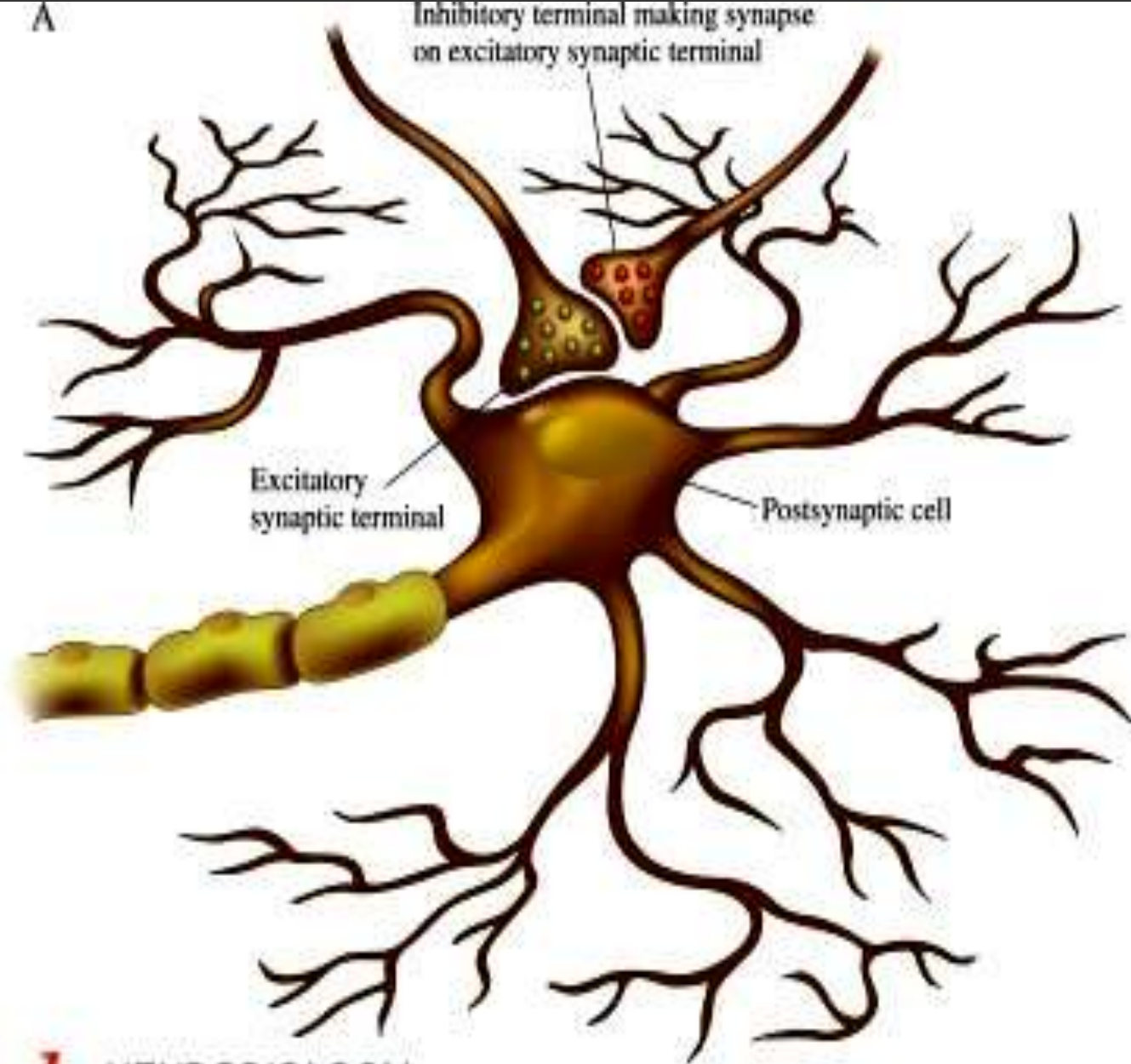

Důsledek obecné chemické sensitivity neuronů: Účinky psychoaktivních látek např. na psychiku

Účinky neurotransmitterů prostřednictvím synaptického přenosu

neurotransmitter	dostupnost (aktivita neurotransmiteru)	lék
serotonin	↓	antidepressivum
acetylcholin	↓	inhibitory acetylcholinesterázy, která odbourává acetylcholin
g-aminomáselná kyselina (GABA)	↓	anxiolytika (usnadňují účinek kyseliny g-aminomáselné)
dopamin	↑	antipsychotika (blokují účinek dopaminu)

Diagrammatical elements:
- A vertical arrow labeled "snížena" (decreased) points downwards, spanning the rows for serotonin, acetylcholin, and GABA.
- A vertical arrow labeled "zvýšena" (increased) points upwards, spanning the row for dopamin.

Synapse jsou nejen chemické, ale i elektrické

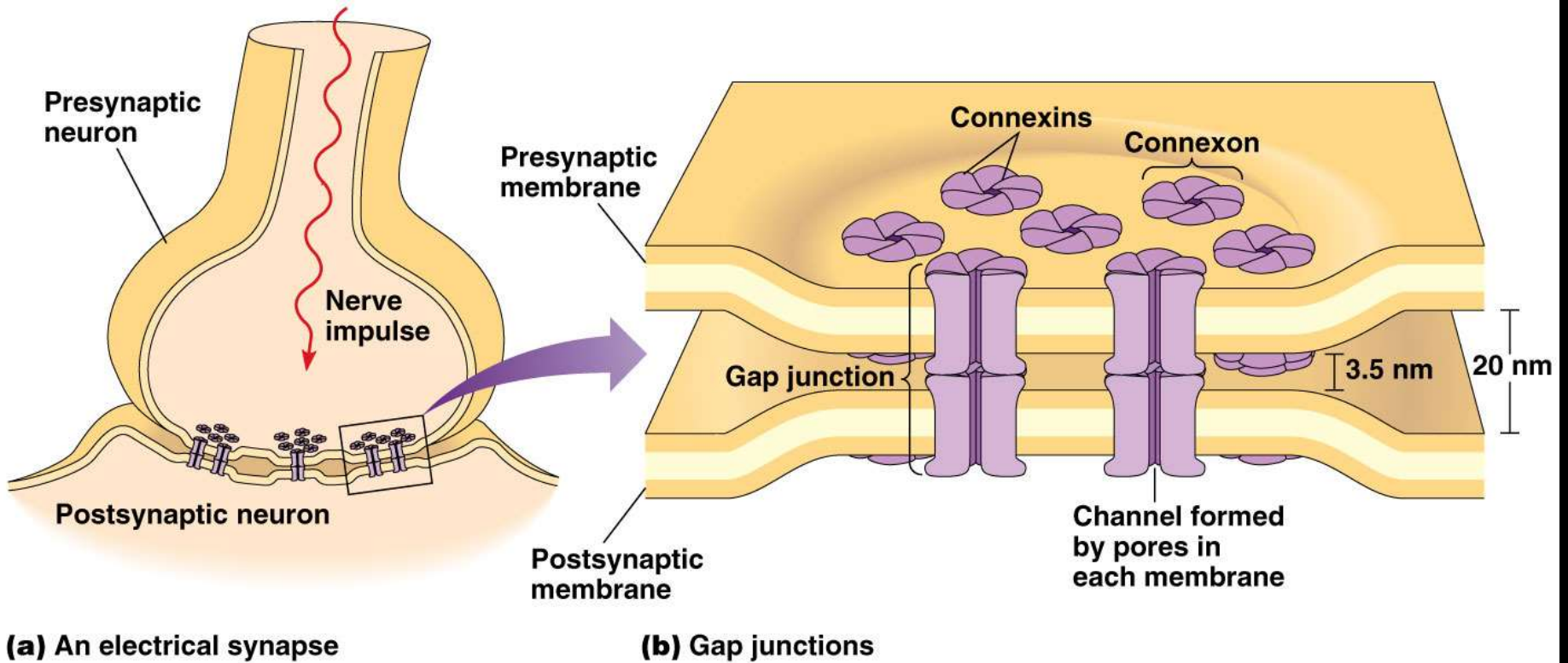

Electrical synapses and their functional interactions with chemical synapses

Alberto E. Pereda

It was thought that electrical synapses were more abundant in invertebrates and cold-blooded vertebrates than in mammals. However, a wealth of data now indicate that electrical synapses are widely distributed in the mammalian brain

In addition to the retina, inferior olive and olfactory bulb, structures in which electrical transmission has been known to occur for some time, electrical synapses have been found in disparate regions of the mammalian CNS.

Synaptic transmission is both chemical and electrical, and interactions between these two forms of interneuronal communication might be required for normal brain development and function.

Based on this bidirectional and analogical (that is, they do not require an action potential) nature, electrical synapses are particularly efficient at detecting the coincidence of simultaneous subthreshold depolarizations within a group of coupled neurons, a phenomenon that increases neuronal excitability and promotes synchronous firing.

Electrical synapses are also highly effective at mediating lateral excitation and increasing the sensitivity of sensory systems, as it occurs in the retina and the primary afferents of escape networks.

Gap junction-mediated lateral excitation has also been shown to occur in a network of cerebellar interneurons, promoting the spread of chemically mediated synaptic inputs between remote dendritic arborizations.

Because of their reliability (transmission at electrical synapses is not probabilistic in nature) and the absence of a synaptic delay (transmission occurs instantaneously), electrical synapses are also a typical feature of escape response networks in both invertebrates and vertebrates.

a Chemical synapse

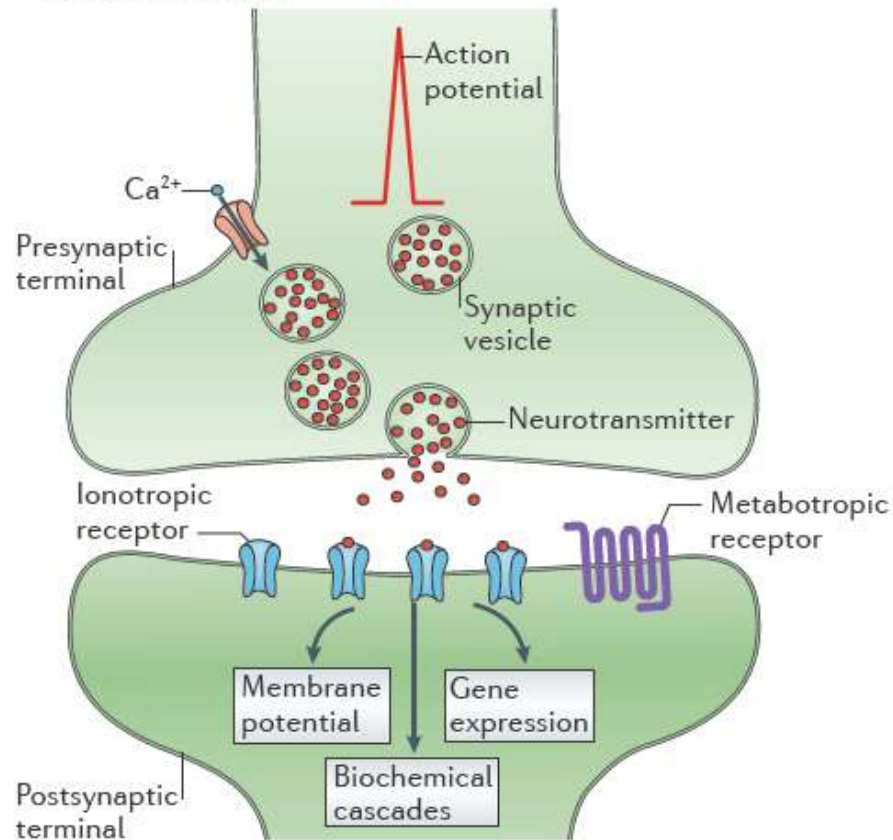

b Electrical synapse

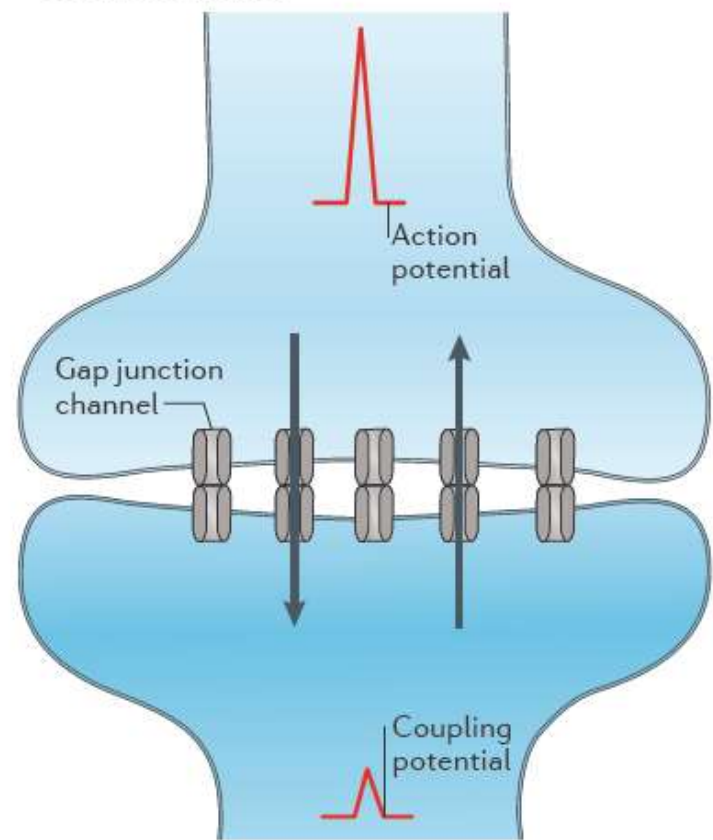
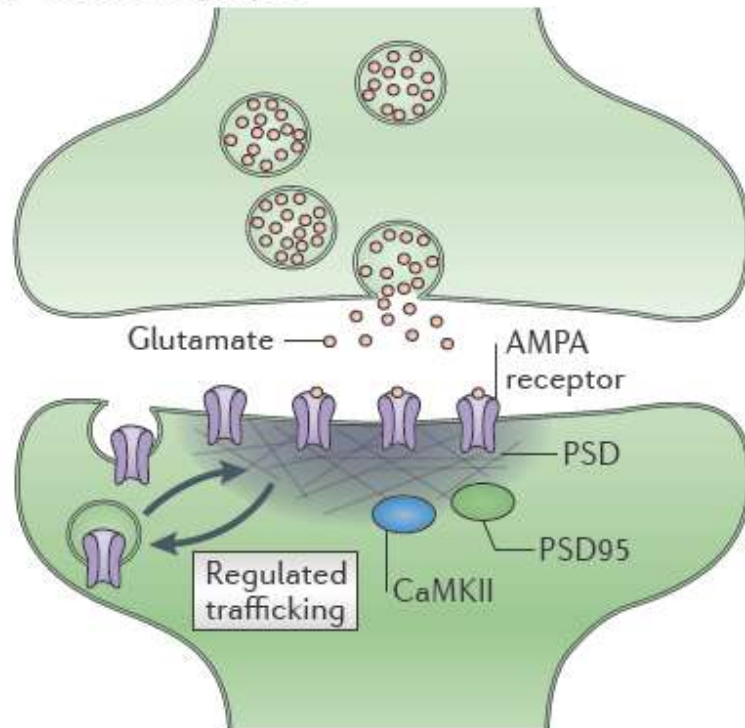

Figure 1 | **The two main modalities of synaptic transmission.** **a** | Chemical transmission requires sophisticated presynaptic molecular machinery that regulates neurotransmitter release in a probabilistic manner upon depolarization of the presynaptic terminal — in this case, by the arrival of an action potential — which leads to the activation of voltage-gated calcium channels (VGCCs). Similarly complex postsynaptic molecular machinery is also required. This includes the presence of ionotropic and metabotropic receptors that are capable of detecting and translating the presynaptic message (neurotransmitters) into various postsynaptic events, ranging from changes in resting membrane potential to gene expression, thus amplifying the presynaptic signal. **b** | Electrical transmission is mediated by clusters of intercellular channels called gap junctions that connect the interior of two adjacent cells, and thereby directly enable the bidirectional passage of electrical currents carried by ions (arrows) as well as intracellular messengers and small metabolites (not illustrated here). Electrical synapses are bidirectional in nature: when a presynaptic action potential propagates to the postsynaptic cell, the membrane resting potential of the postsynaptic cell simultaneously propagates to the presynaptic cell.

a Chemical synapse



b Electrical synapse

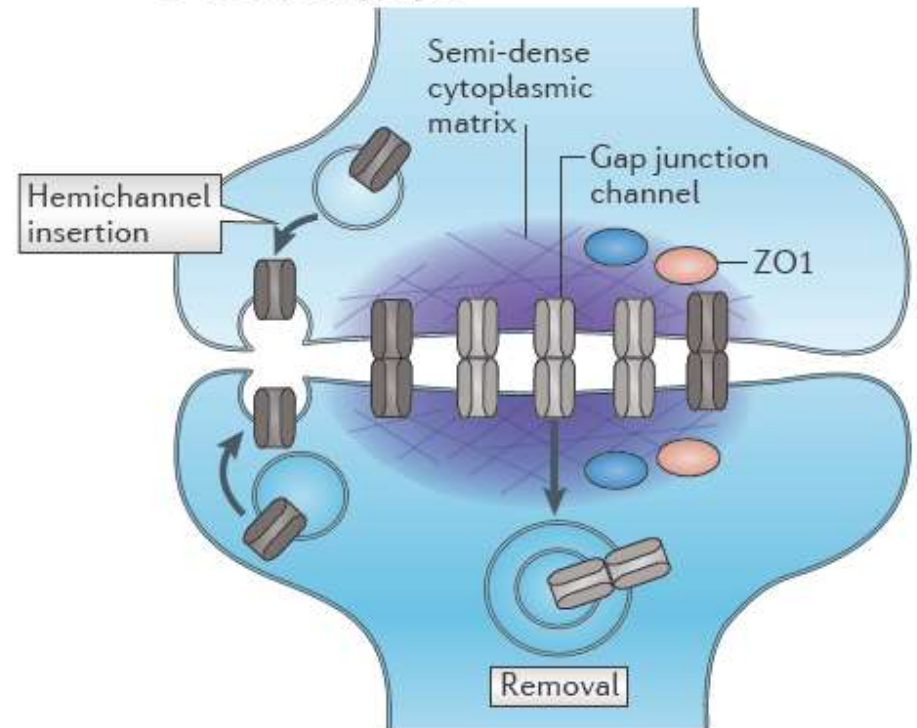

Figure 2 | **Trafficking of channels at chemical and electrical synapses.** **a** | Ionotropic glutamate receptors are trafficked in and out of synapses. Postsynaptic densities (PSDs) provide a scaffold that helps to regulate this trafficking. PSD95 and calcium/calmodulin-dependent protein kinase II (CaMKII) are both abundant components of PSDs. Regulated trafficking of AMPA receptors is thought to underlie the modification of synaptic strength at glutamatergic synapses. **b** | There is turnover of gap junction channels at electrical synapses. New connexons are trafficked as unpaired hemichannels to the membrane in vesicles, where they are inserted at the periphery of the gap junction plaque and dock with hemichannels in the apposing membrane. They are internalized as small clusters of entire channels (light grey) into either of the coupled cells from regions near the centre of the plaque. Various proteins make up the 'semi-dense cytoplasmic matrix', which acts as a scaffold for these channels. Zonula occludens protein 1 (ZO1) is a structural component of this scaffold. By contrast, CaMKII (not shown) seems to be a non-obligatory component of the macromolecular complex, with functions that might be similar to those at PSDs of chemical synapses.

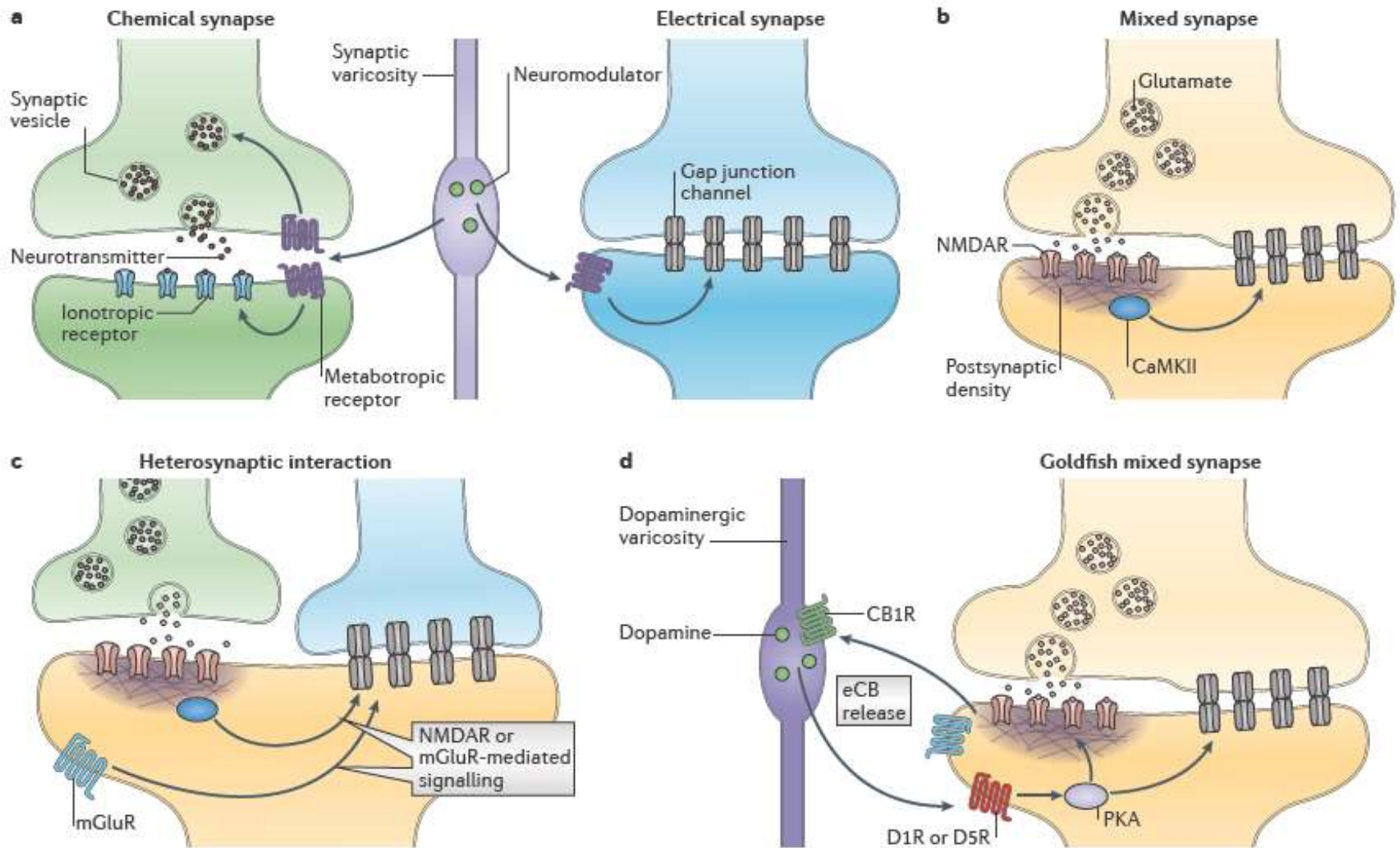

Figure 4 | Types of interactions between electrical and chemical synapses in the adult nervous system.

a | Neurotransmitter modulators released by nearby synaptic terminals (purple) regulate the synaptic strength of chemical and electrical synapses through activation of G protein-coupled metabotropic receptors. Regulation at chemical synapses could occur pre- or postsynaptically. **b** | Electrical and chemical synapses coexist at mixed synapses. Glutamatergic synapses regulate the strength of electrical synapses by a postsynaptic mechanism that includes the activation of NMDA receptors (NMDARs) and calcium/calmodulin-dependent protein kinase II (CaMKII). **c** | Regulation of electrical synapses by glutamatergic transmission could also be heterosynaptic. Nearby glutamatergic synapses can regulate electrical transmission through NMDAR or metabotropic glutamate receptor (mGluR) activation. **d** | Another mechanism of interaction at goldfish mixed synapses results when synaptic activity leads to mGluR activation, which in turn triggers

Paměť



some learning history

Descartes (1596-1650): "When the mind wills to recall something, this volition causes the little gland (the pineal), by inclining successively to different sides, to impel the animal spirits towards different parts of the brain, until they come upon that part where the traces are left of the thing it wishes to remember."

Ramón y Cajal (1894) "... mental exercise facilitates a greater development of the protoplasmic apparatus and of the nervous collaterals in the part of the brain in use. In this way, pre-existing connections between groups of cells could be reinforced by multiplication of the terminal branches of protoplasmic appendices and nervous collaterals."

D.O. Hebb (1949) "coincident activity" initiates the growth of new synaptic connections as part of long-term memory storage. "reverberatory circuit" for short-term memory.

Lashley (1963) Lesioning rat brains, trained to negotiate a maze. No evidence of localization of memory, memory deficits were related to the extent of the lesions. Lead to his theory of mass action

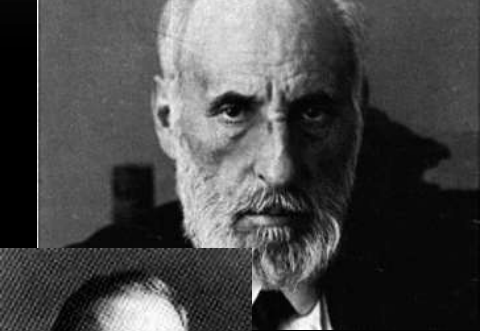

Paměť

idea: molecules contain memory (transfer of molecule transfers memory)

Holger Hyden: new specific RNA is created for each memory. Hyden's hypothesis implied that the patterns of stimulation activated by learning could introduce changes in RNA.

(current interpretation: long term learning requires protein synthesis)

G Unger: memory specific peptide scotophobin. Could inject/transfer fear of the dark from rat to mouse. (Turned out to inhibit melatonin synthesis in pineal gland, and somehow that creates scotophobic behavior)

McConnell (1966). Classical conditioning of flatworms. Feed trained worms to untrained ones. Untrained ones show conditioned response (or learned faster). Same for T-maze experiments. But: random shocks had same effect than conditioning.

OPAKOVÁNÍ MATKOU MOUDROSTI A SYNAPTICKÁ PLASTICITA

- Kromě rychlého synaptického přenosu existuje i pomalý. Bombardování synapsí vzruchy po druhých poslech a rychlém, kanály řízeném přenosu, vzbudí posléze i třetí posly, časné geny a expresi dalších genů, které syntetizují látky potřebné ke splnění poselství doručeného přes synapsi. Rychlý přenos trvá několik milisekund, zatímco pomalý od sekund po hodiny. Pomalým přenosem pozměněný metabolismus a stavba synapsí mají dopad na množství základních funkcí NS např. poplachové reakce na stres, účinky drog a farmak, změny při ukládání paměťové stopy.
- Zda je podkladem učení a paměti, zůstává předmětem debat

Úrovně synaptické plasticity neuronové sítě

(a) Plasticity in a neural chain

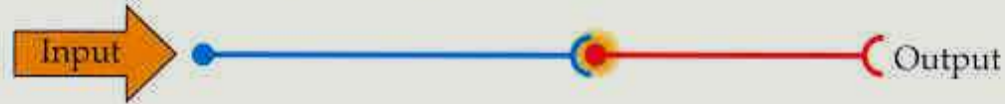

(b) Plasticity in a superordinate circuit

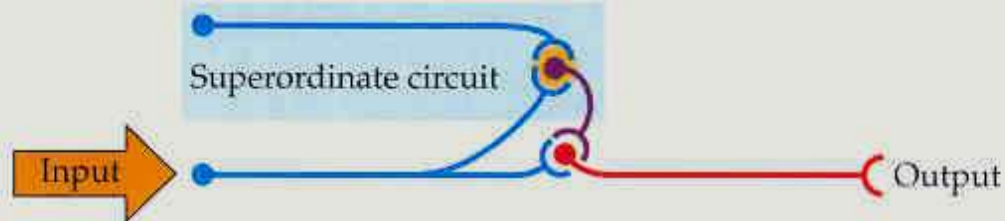

(c) Plasticity in a cell assembly

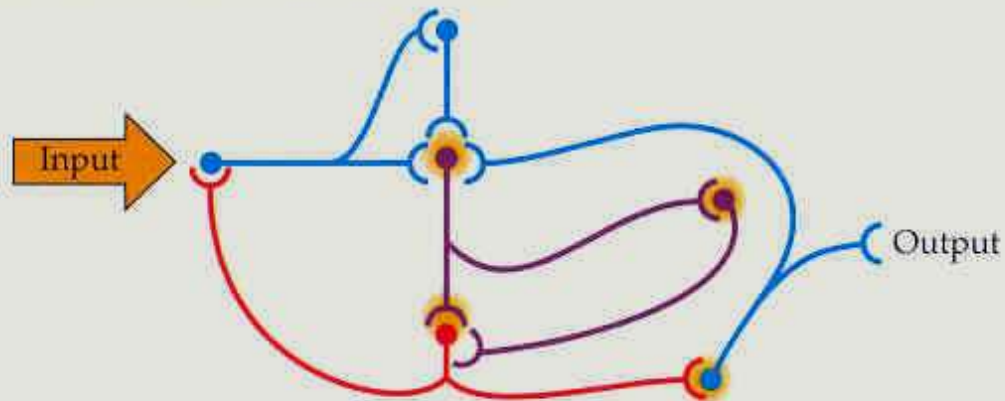

18.1 Sites of Synaptic Plasticity in Neural Networks

Changes at sites of synaptic plasticity—such as the sites shown here (highlighted in orange) in a neural chain (a), a superordinate circuit (b), and a cell assembly (c)—may underlie memory storage.

Before training

After training

(a) Changes involving synaptic transmitters

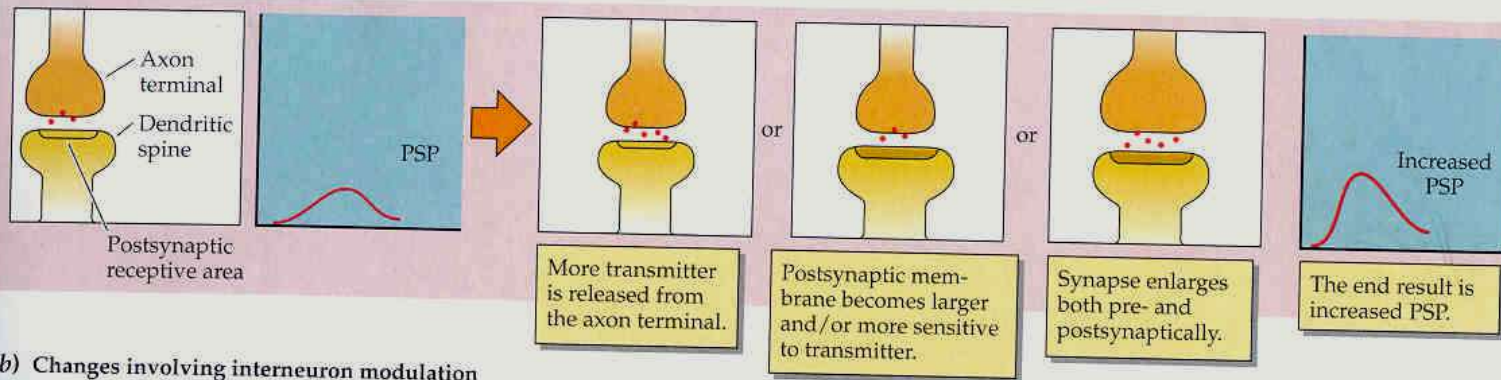

(b) Changes involving interneuron modulation

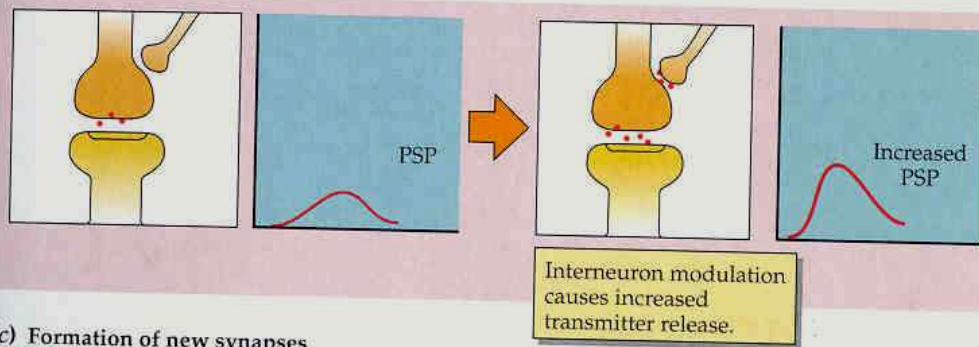

18.2 Synaptic Changes That May Store Memories

After training, each action potential in the relevant neural circuit causes increased release of transmitter molecules (red dots). The postsynaptic potential (PSP) therefore increases in size (as indicated by the graphs). (a) An increase in size of the postsynaptic receptor membrane causes a larger response to the same amount of transmitter release. (b) An interneuron modulates the polarization of the axon terminal and causes the release of more transmitter molecules per nerve impulse. (c) A neural circuit that is used more often increases the number of synaptic contacts. (d) A more frequently used neural pathway takes over synaptic sites formerly occupied by a less active competitor.

Různé typy modifikací

(c) Formation of new synapses

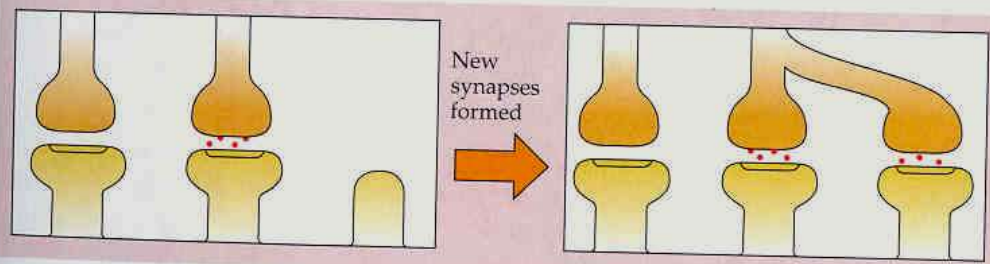

(d) Rearrangement of synaptic input

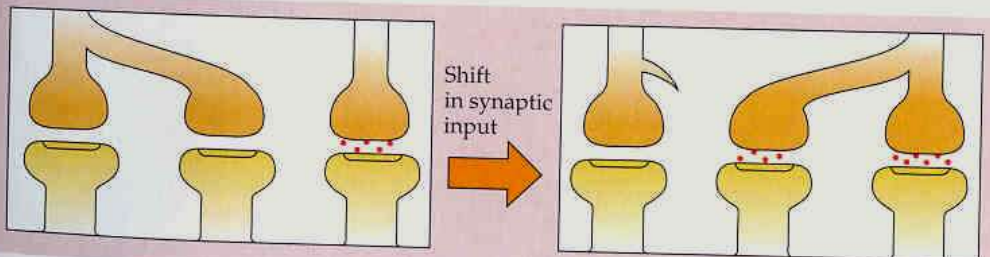

Možná místa modifikací na presynaptické straně

from Atwood and Karunanithi (2002)

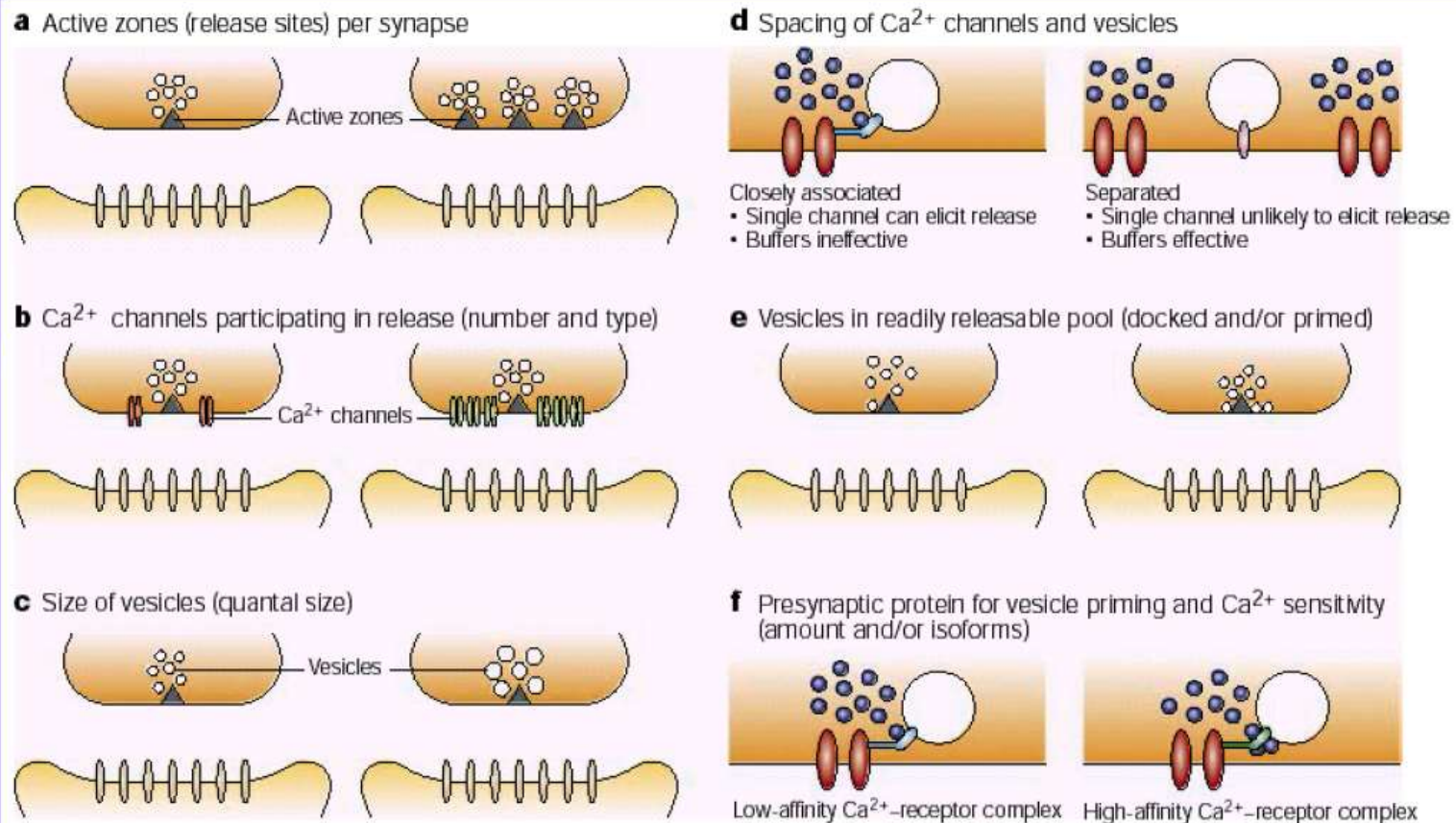

Figure 3 | **Presynaptic determinants of synaptic strength.** Several hypothetical mechanisms are illustrated. **a** | Individual synapses have different numbers of release sites (active zones). An extreme example is the calyx of Held in the mammalian auditory pathway. **b** | Voltage-dependent Ca^{2+} channels at individual active zones differ in number and/or type, allowing more Ca^{2+} to enter at some active zones after a nerve impulse, eliciting the fusion of more synaptic vesicles. **c** | Synaptic vesicles differ in size, generating correspondingly different quantal units that depend on their transmitter content. **d** | The effectiveness of individual Ca^{2+} channels to cause vesicle fusion depends on channel-vesicle spacing. Intracellular buffers have a more significant influence on transmission when channels and vesicles are more separated. **e** | Synaptic vesicles that are available for release (close to or docked at the synaptic membrane, and appropriately primed) are more numerous at some synapses. **f** | Qualitative and quantitative differences in presynaptic proteins impart different properties to the Ca^{2+} receptors, affecting the probability of vesicular fusion after Ca^{2+} entry.

Synaptická plasticita

Donald Hebb, 1949

LTP – dlouhodobá potenciace, 1983, 100Hz

LTD – dlouhodobá deprese, 3 Hz



554 CHAPTER 18

(a) Normal synaptic transmission

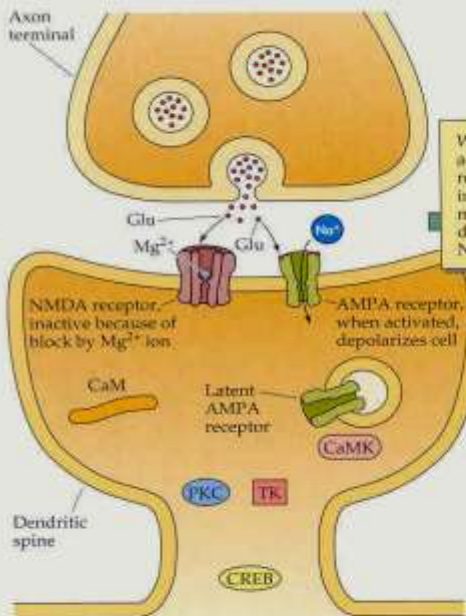

(b) Induction of LTP

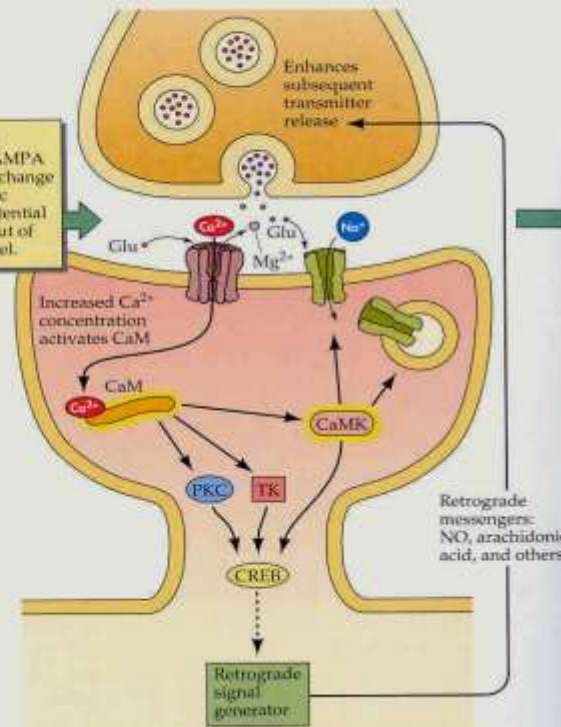

(c) Enhanced synapse, after induction of LTP

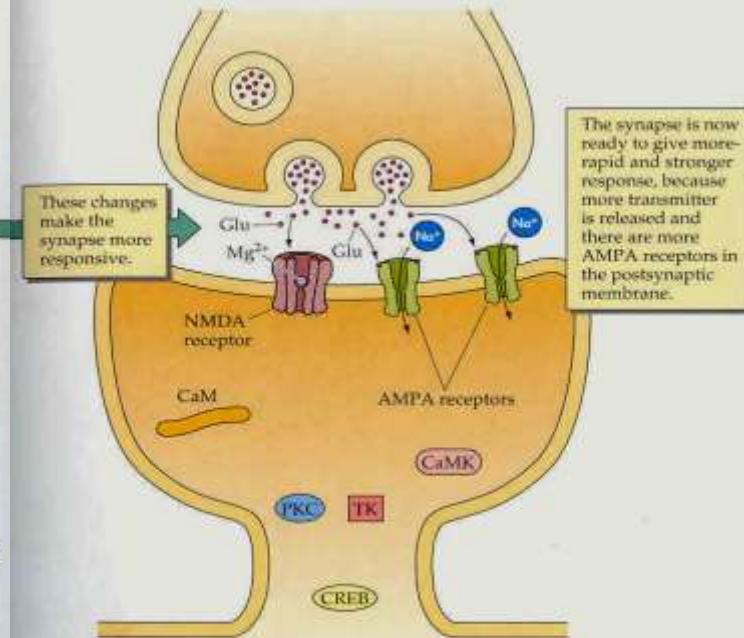

NMDA ionotropní receptor potřebuje k aktivaci jak a) ligand, tak i b) silnou depolarizaci. S narušenými NMDA receptory se ztratila schopnost prostorového učení.

Presynaptic action potentials



A. Summation

Postsynaptic E_m

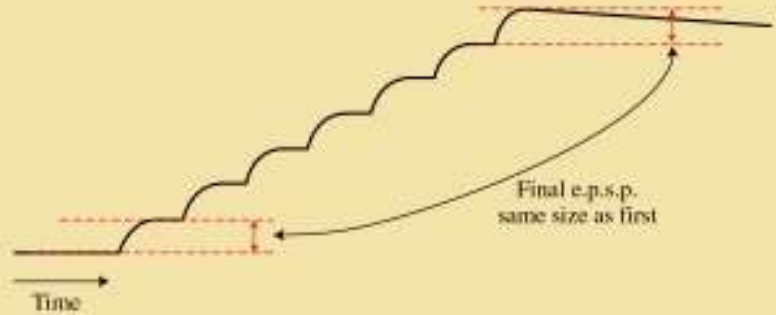

B. Facilitation

Postsynaptic E_m

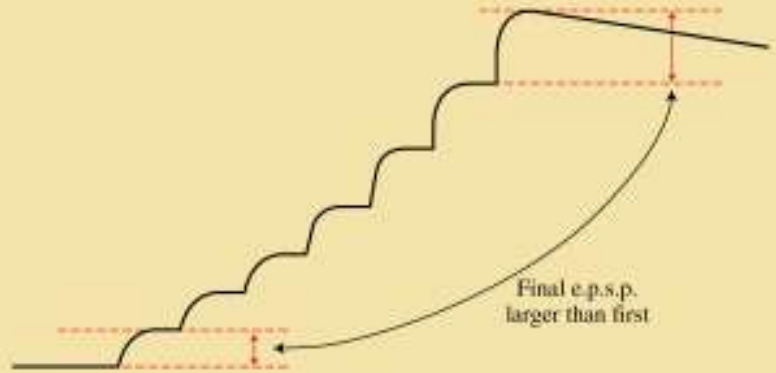

C. Depression

Postsynaptic E_m



Synaptická plasticita

Potenciace:

A. Sumace-podobná svalové

B. Facilitace-změna účinnosti

C. Deprese

Potenciace

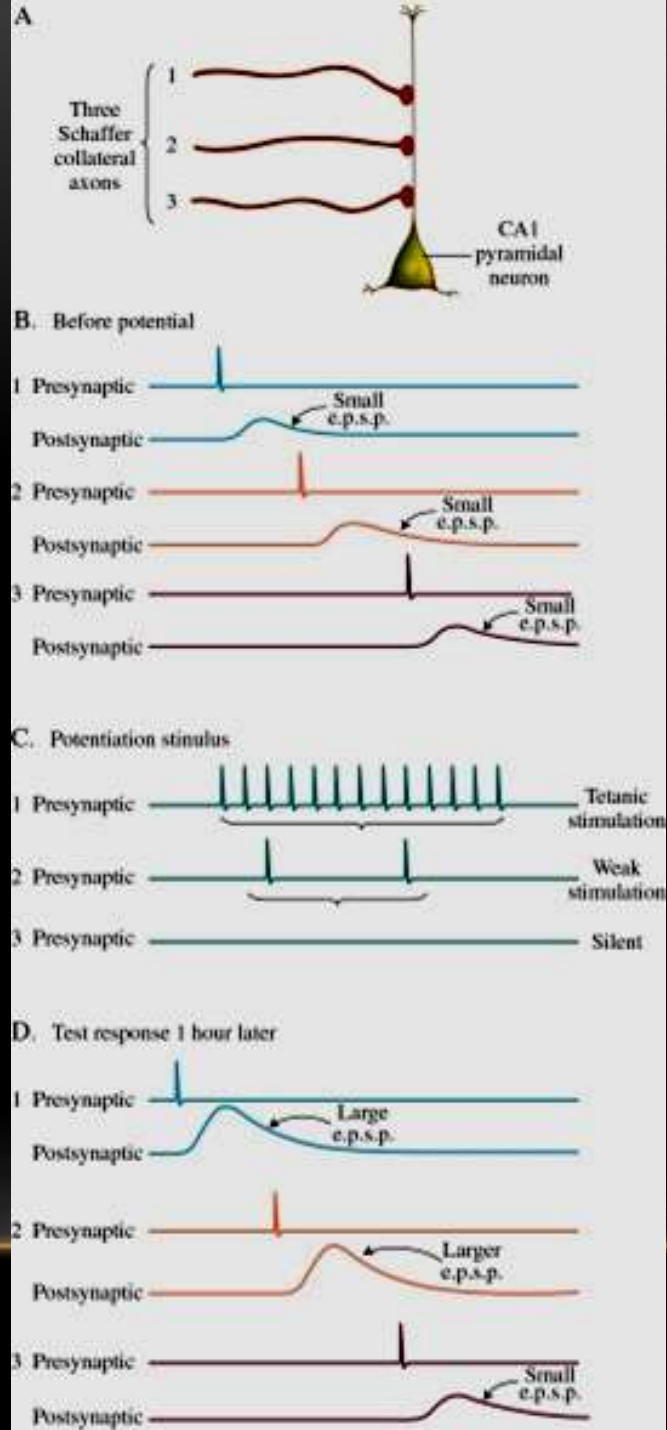

Potenciace i na postsynaptické straně

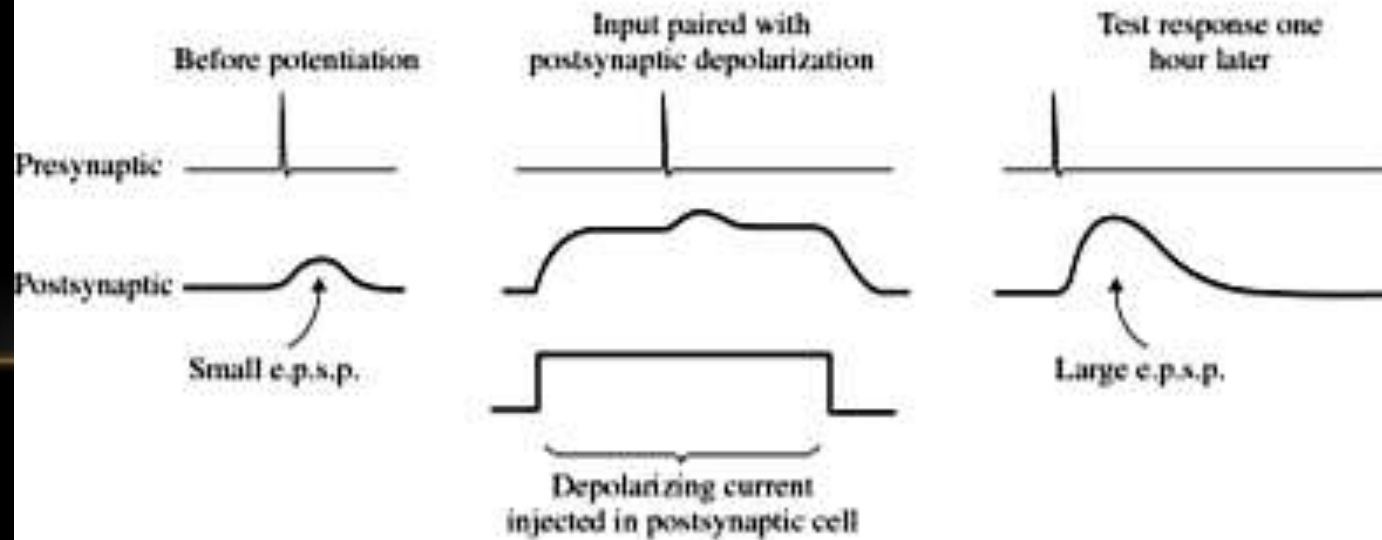
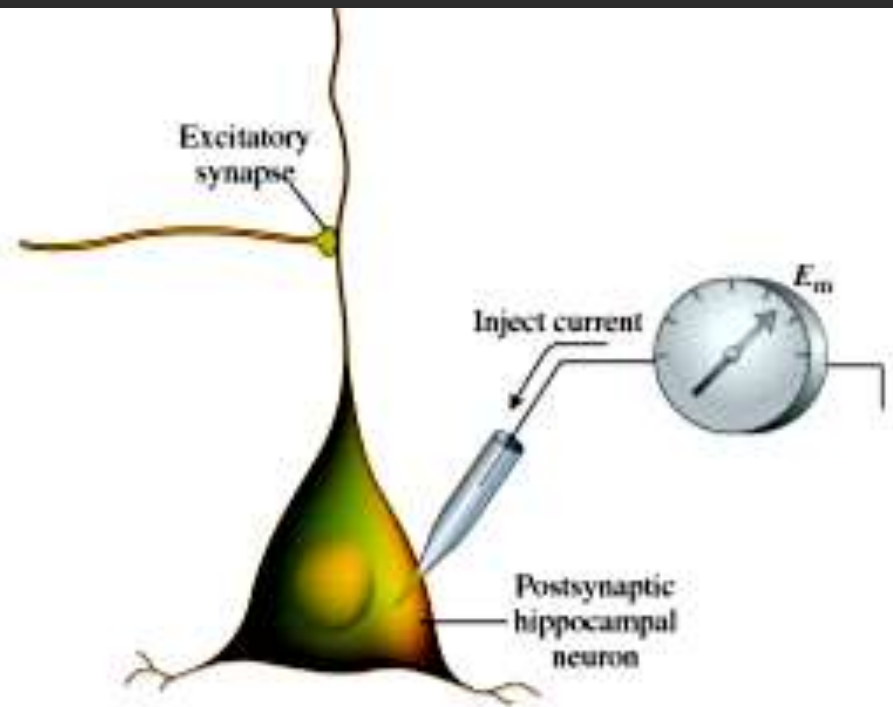

Dlouhodobá aktivace nenechá proteosyntézu v klidu.

Transkripční faktory (např. Zenk a c-Fos) proto signalizují aktivitu neuronů.

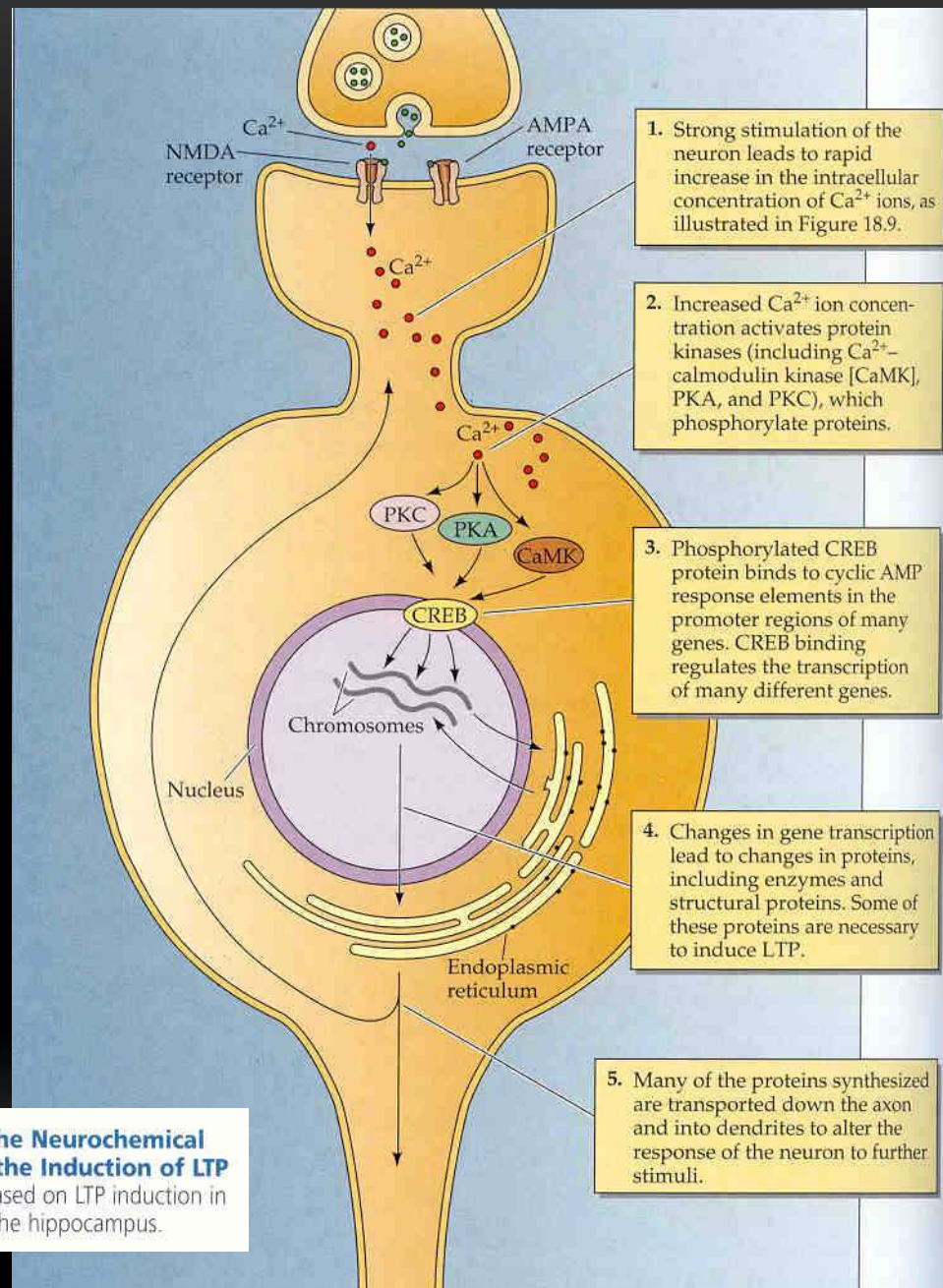

18.10 Steps in the Neurochemical Cascade during the Induction of LTP

This illustration is based on LTP induction in the CA1 region of the hippocampus.



The Nobel Prize in Physiology or Medicine 2000

"for their discoveries concerning signal transduction in the nervous system"



Arvid Carlsson

1/3 of the prize

Sweden

Göteborg University
Gothenburg, Sweden

b. 1923

Paul Greengard

1/3 of the prize

USA

Rockefeller University
New York, NY, USA

b. 1925

Eric R. Kandel

1/3 of the prize

USA

Columbia University
New York, NY, USA

b. 1929
(in Vienna, Austria)

Molecular Biology of Memory Storage:

The Persistence of Memory

The Study of Memory Has Two Parts:

(1) The *Systems* Problem of Memory:

Where in the brain is memory stored?

(2) The *Molecular* Problem of Memory:

How is memory stored at each site?

There are Two Major Forms of Long-Term Memory

Explicit (Declarative)

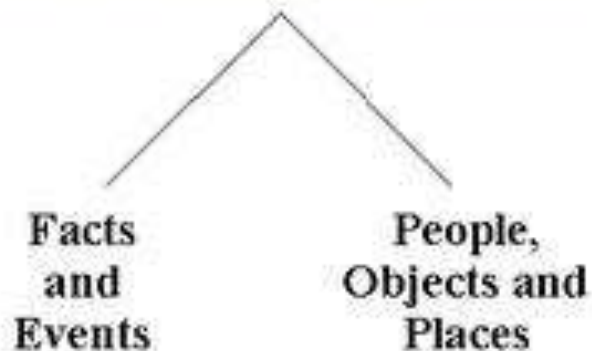

Medial Temporal Lobe
Hippocampus

Requires Conscious Attention

Implicit (Procedural)

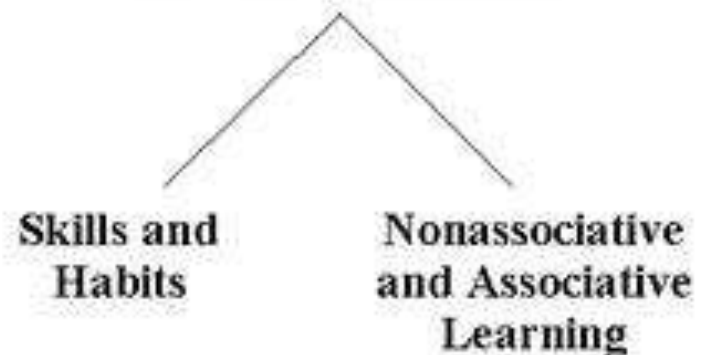

Amygdala, Cerebellum,
Reflex Pathways

Does Not Require Conscious Attention

Implicit and Explicit Memory Share 3 Features in Common

1 There are Stages to Memory Storage

2 Repetition Converts Short- to Long-Term Memory

3 Long-Term Memory Requires New Protein Synthesis

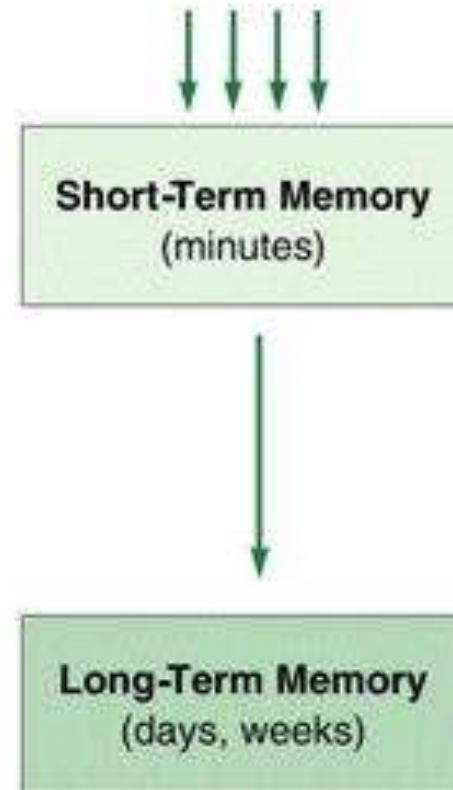
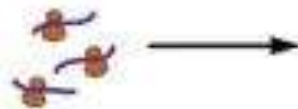

There are Two Major Forms of Long-Term Memory

Explicit (Declarative)



Place:
Spatial Memory

Medial Temporal Lobe
Hippocampus

Requires Conscious Attention

Implicit (Procedural)



Nonassociative Learning:
Learned Fear (Sensitization)

Reflex Pathways

Does Not Require Conscious Attention

The Human Brain
is complex:
 10^{12} Neurons

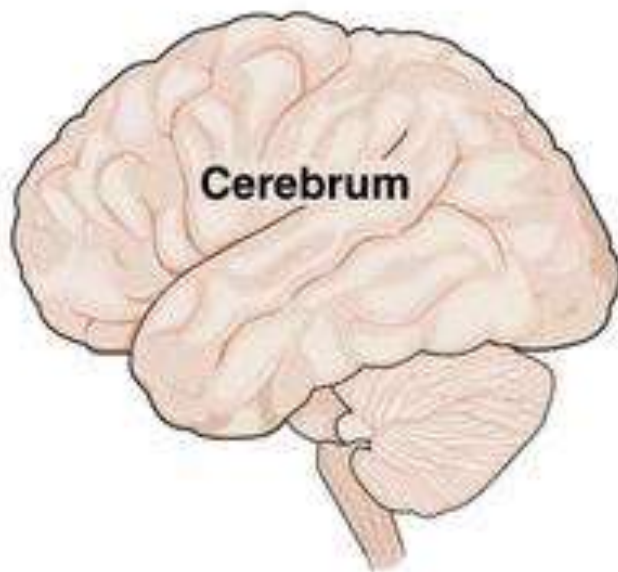

The *Aplysia* Brain
is simple:
 2×10^4 Neurons

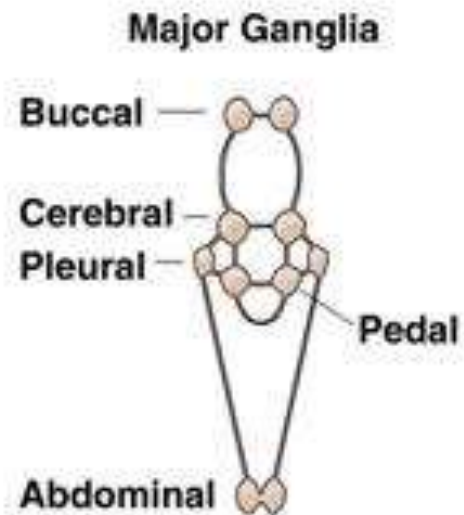

The Gill Withdrawal Reflex has a Simple Stereotypical Neural Circuit. Repetition of Sensitization Training Leads to Altered Gene Expression and the Growth of New Synaptic Connections.

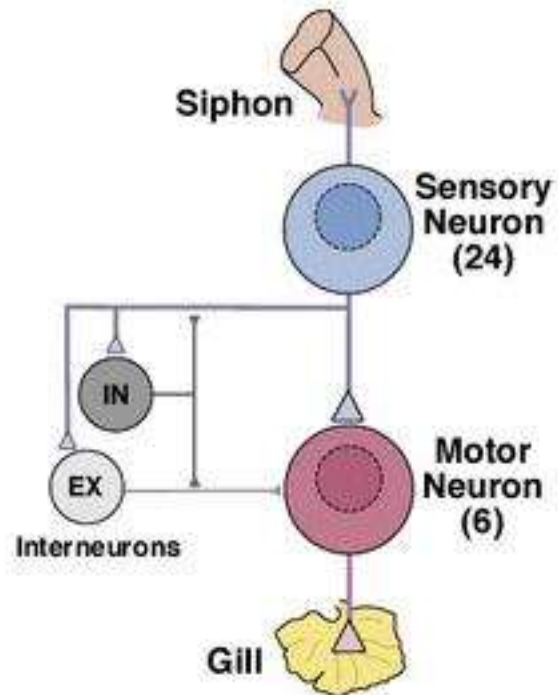

The Gill Withdrawal Reflex has a Simple Stereotypical Neural Circuit. Repetition of Sensitization Training Leads to Altered Gene Expression and the Growth of New Synaptic Connections.

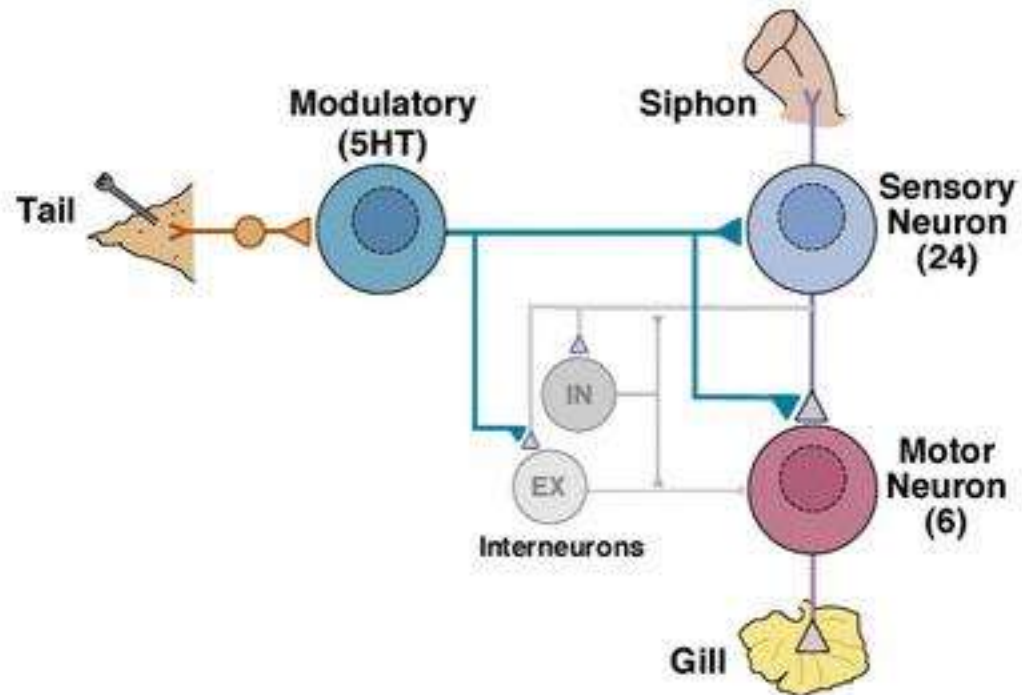

The Gill Withdrawal Reflex has a Simple Stereotypical Neural Circuit. Repetition of Sensitization Training Leads to Altered Gene Expression and the Growth of New Synaptic Connections.

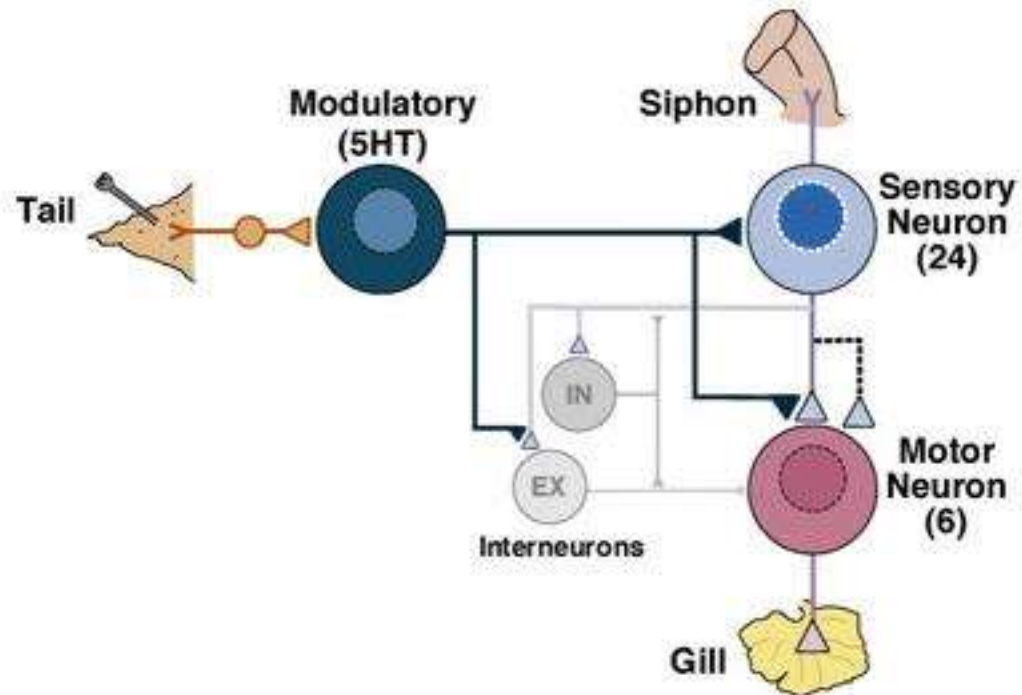

Habituace a senzitivace u zeje
Aplysia californica



HABITUACE U *APLYSIA*

Dotek na sifon...

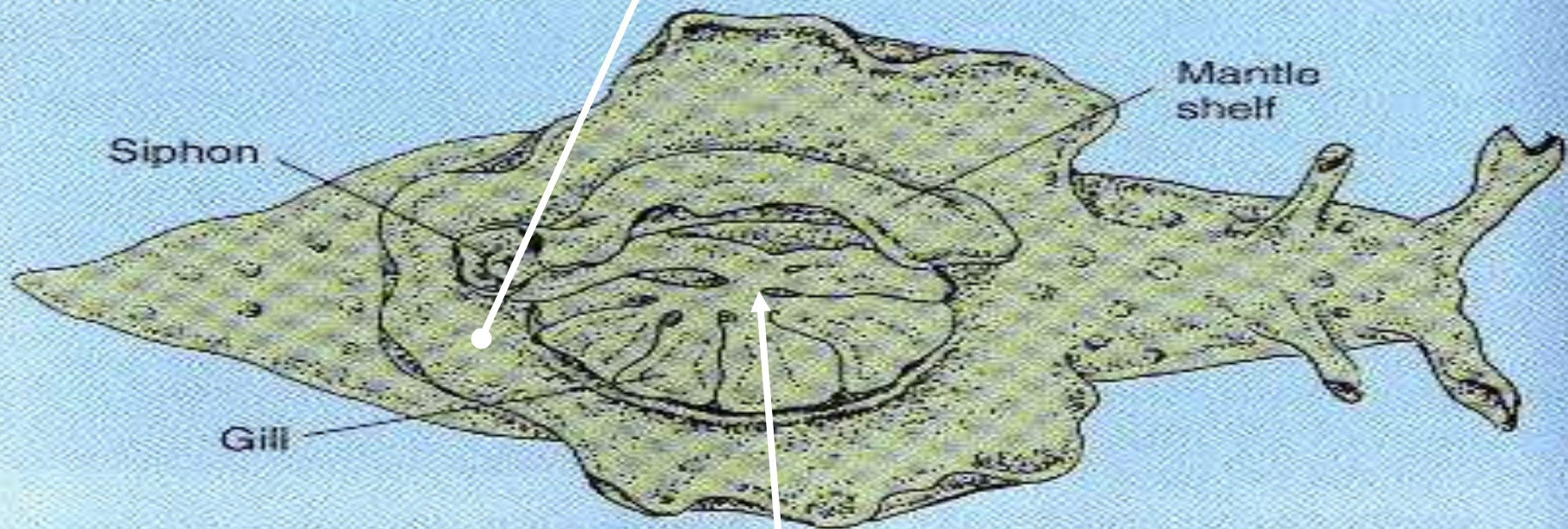

...a žábra se stáhnou

OBRANNÁ REAKCE STAŽENÍ ŽABER *APLYSIA*

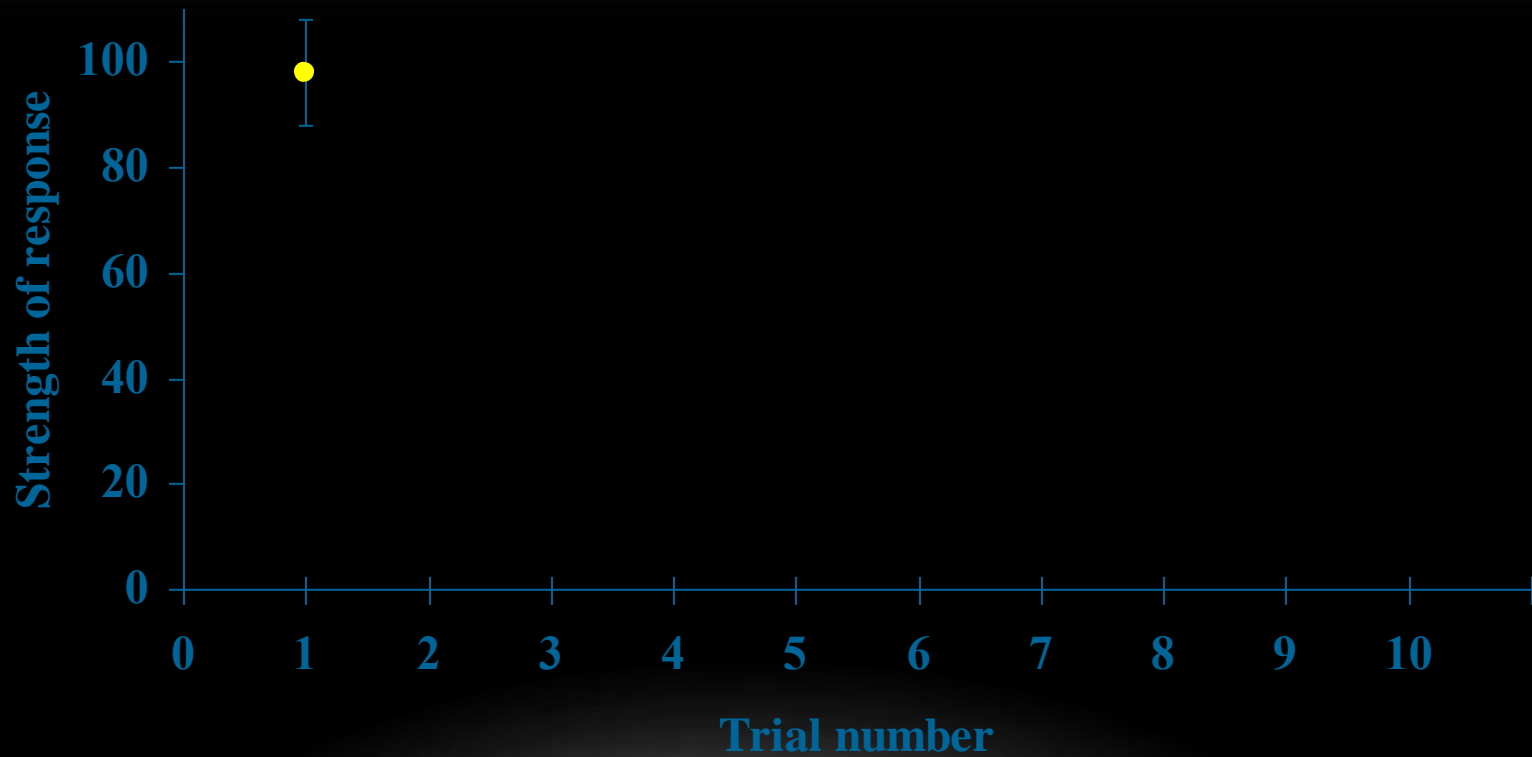

HABITUACE U APLYSIA

Dotek na sifon...

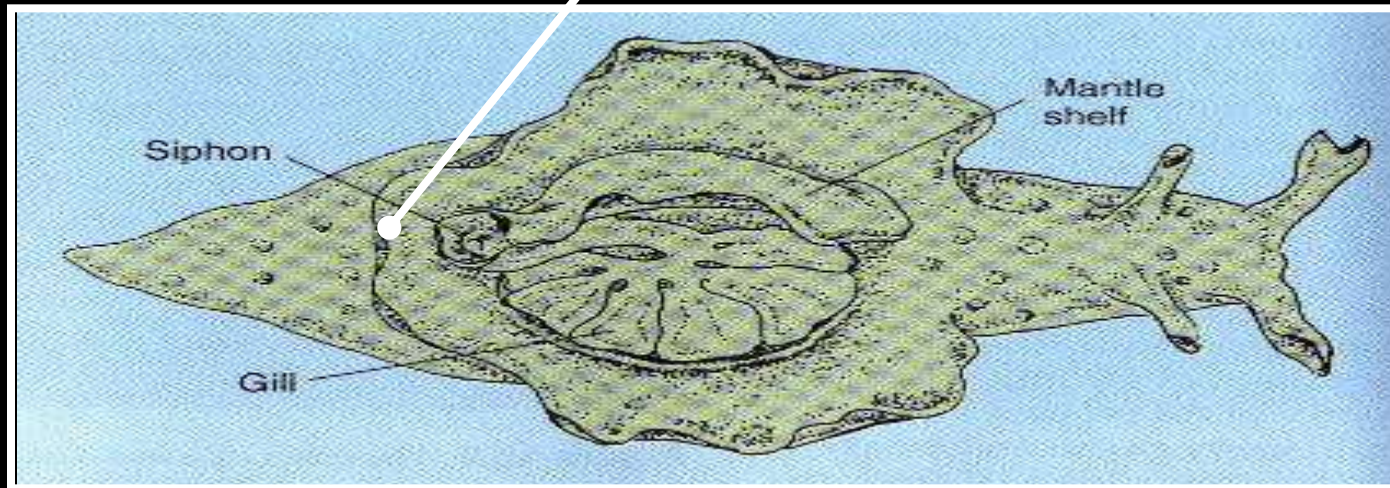

...a žábra se stáhnou

OBRANNÁ REAKCE STAŽENÍ ŽABER *APLYSIA*

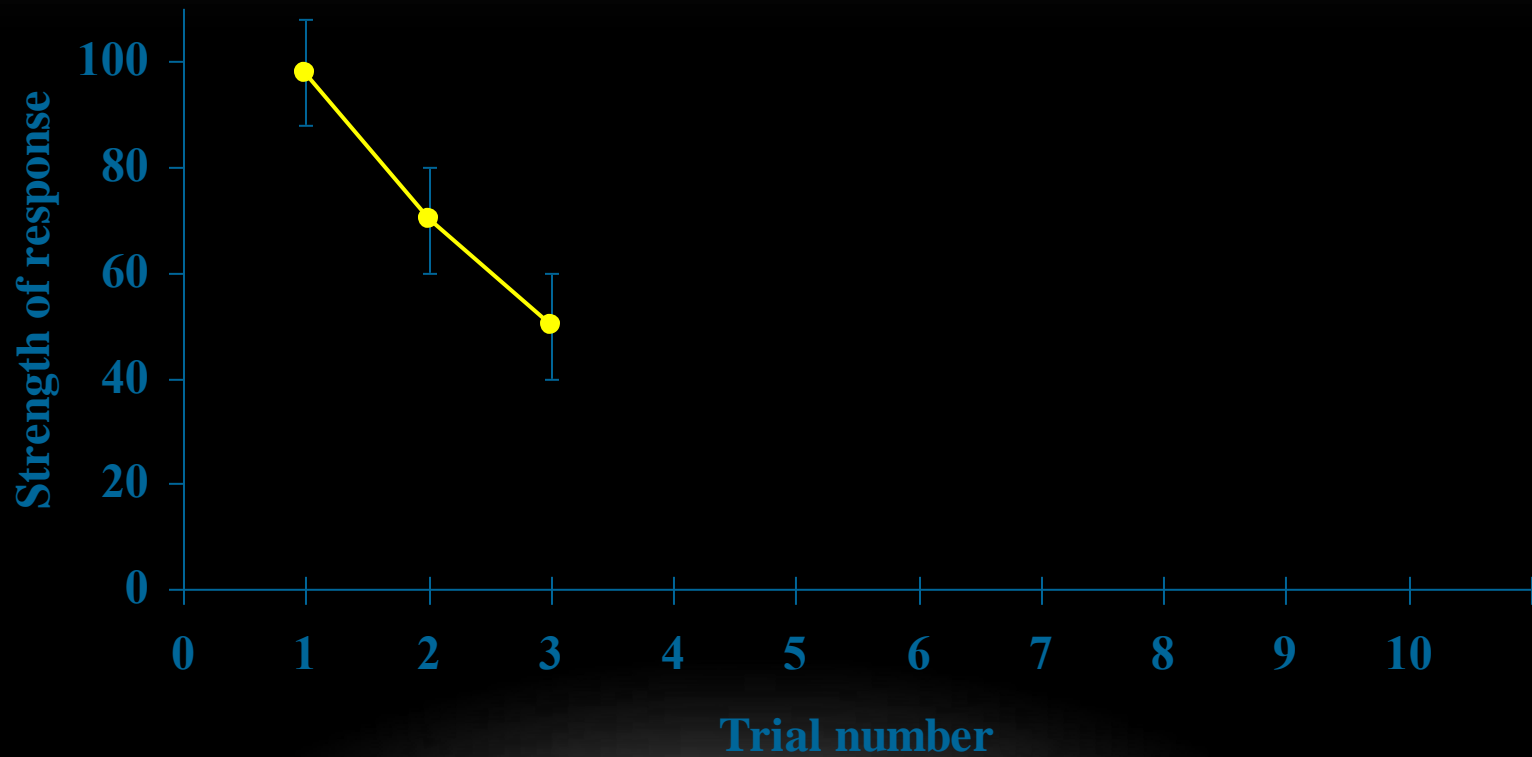

OBRANNÁ REAKCE STAŽENÍ ŽABER *APLYSIA*

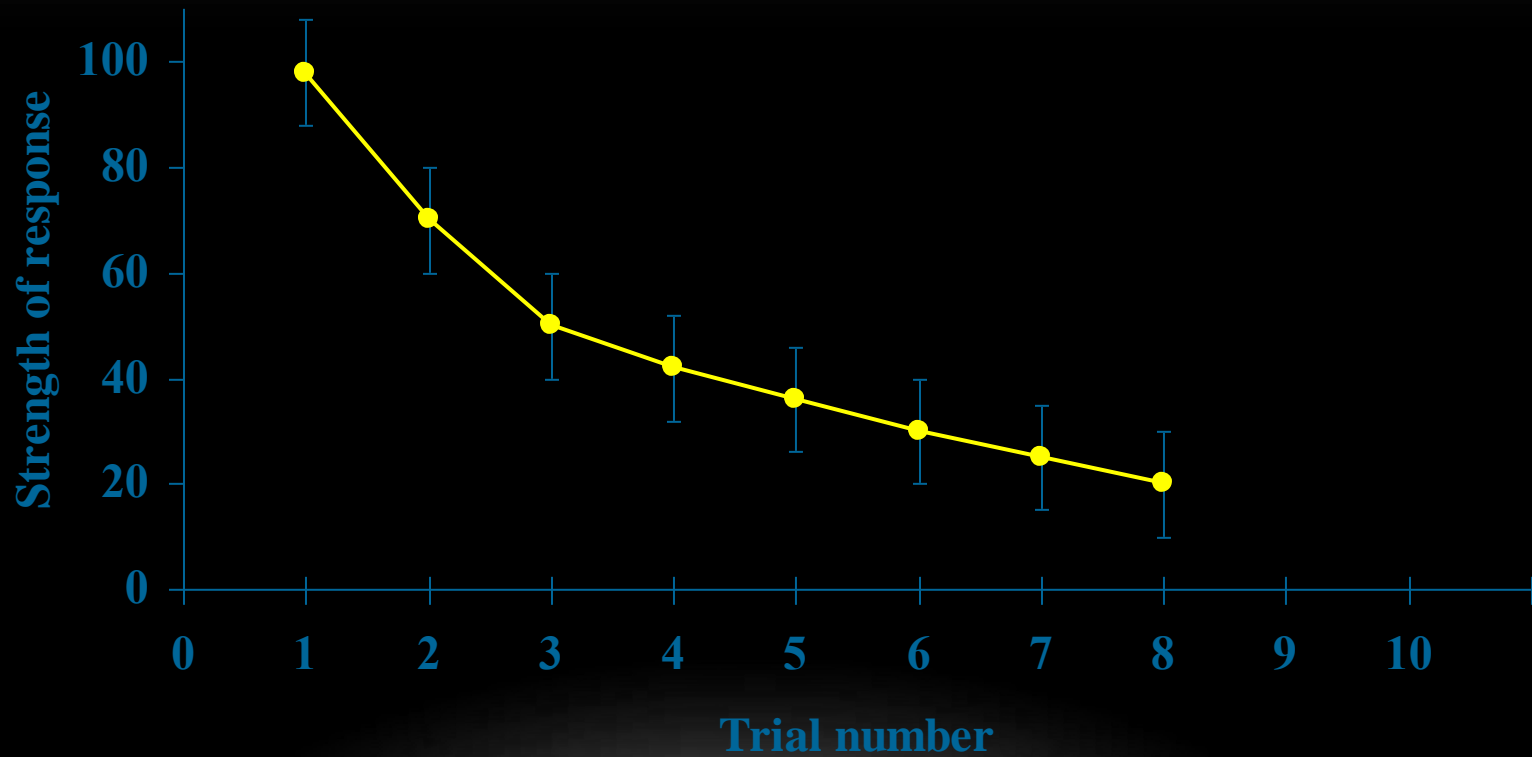

HABITUACE U APLYSIA

Dotek na sifon...

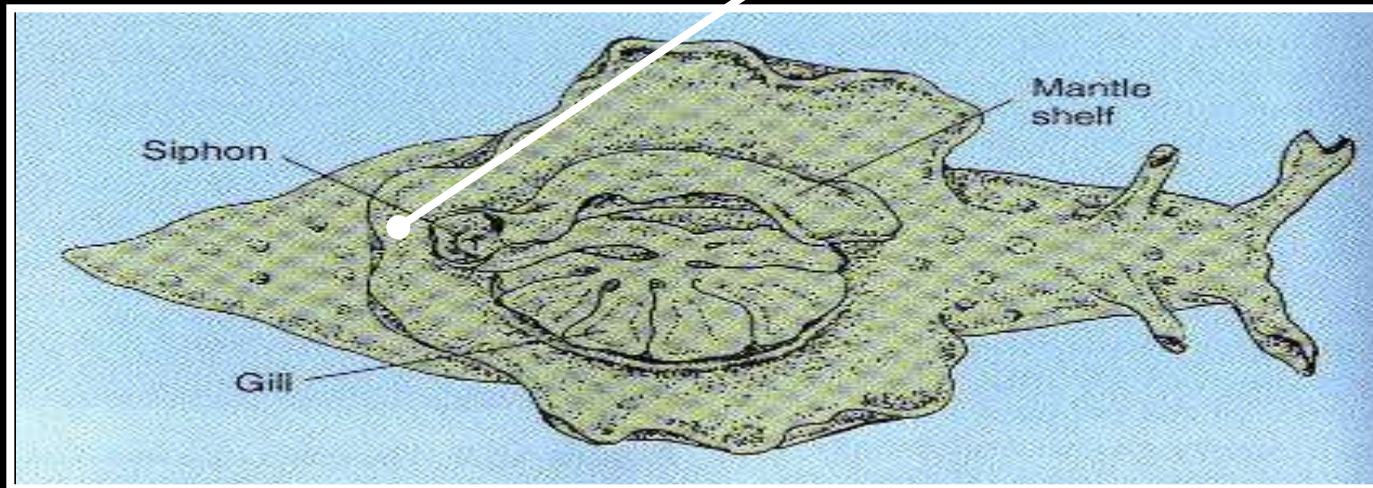

...a žábra ukážou téměř žádnou reakci

habituation - measuring the effectiveness of synaptic transmission
decrease of number of transmitter vesicles from the presynaptic
sensory neuron

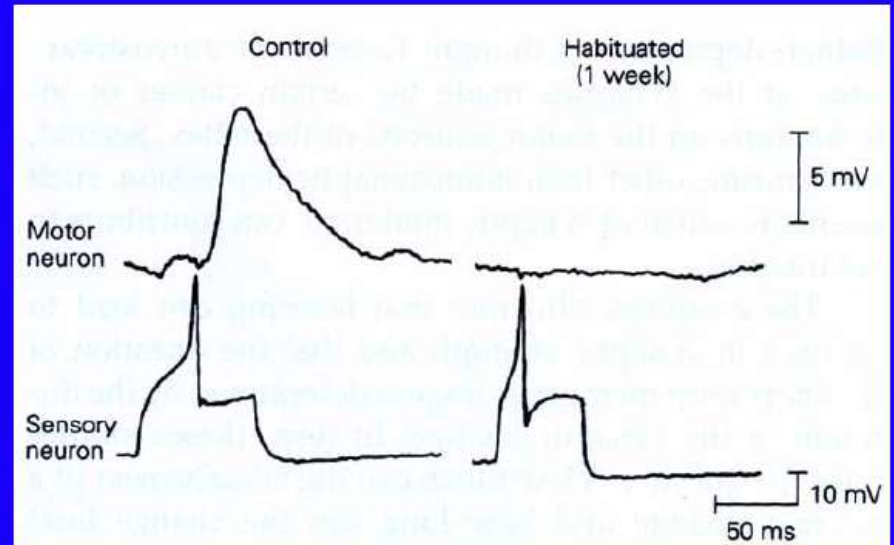
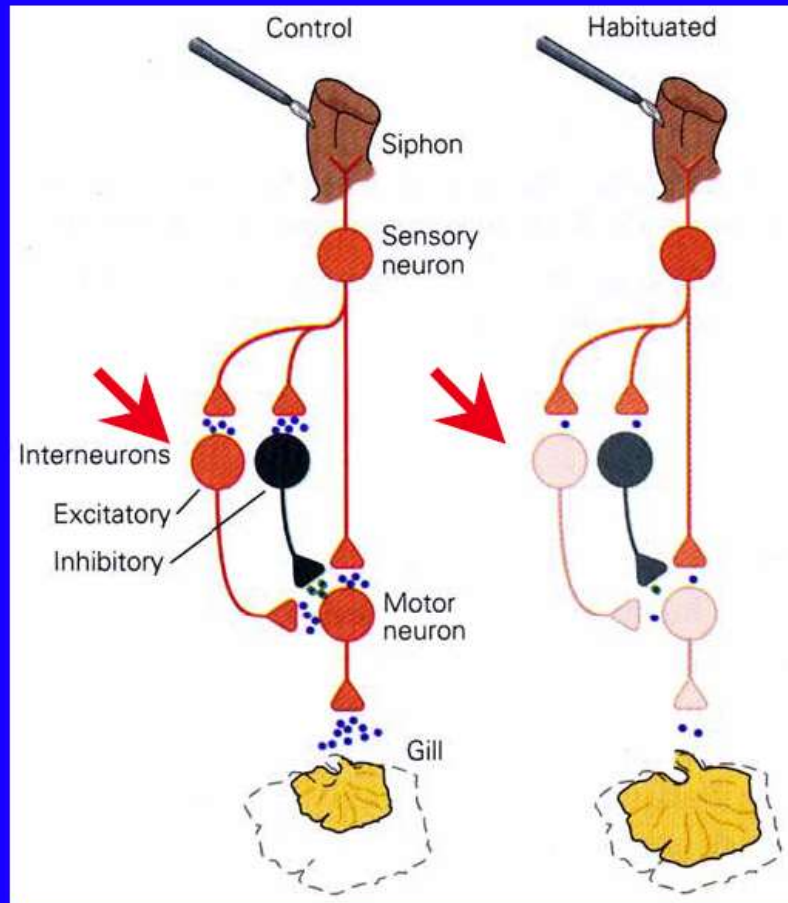

short-term habituation (1×10
stimuli): synaptic depression
long-term habituation (4×10
stimuli over hours or days):
reduction of synaptic contacts

from: Kandel, Schwartz, Jessell: Principles of Neural Science

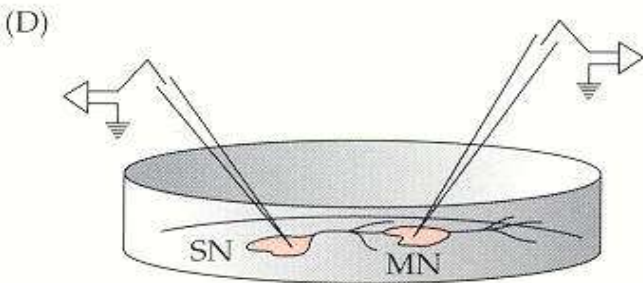
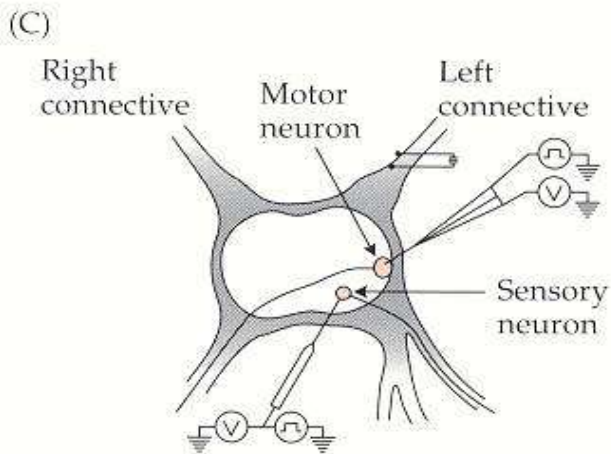
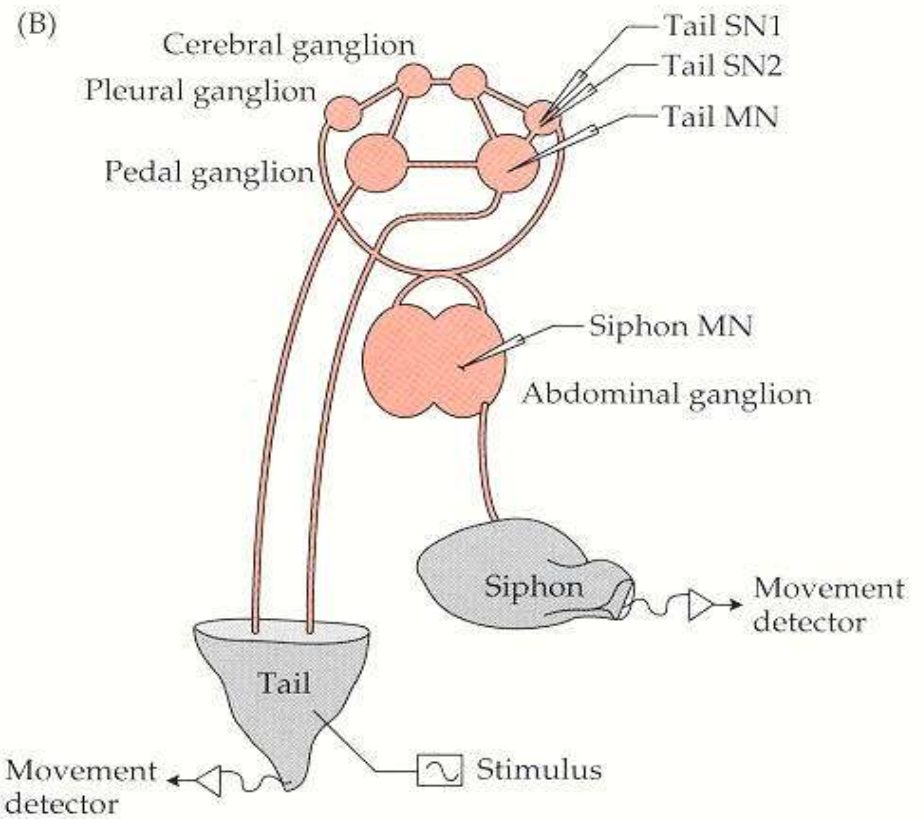
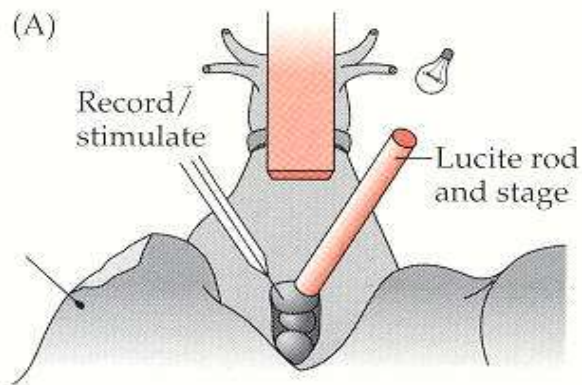

10.8 Experimental preparations for cellular analysis

The cellular basis of gill and siphon withdrawal can be studied at several levels of analysis. (A) In the most intact preparation the abdominal ganglion is externalized, and recordings from neural elements are made during reflex actions. (B) In what is known as the semi-intact preparation, the entire central nervous system (CNS) is removed. In some cases peripheral organs (such as the gill, siphon, and tail) are left attached to the CNS by their peripheral nerves. (C) In a third preparation, single ganglia (or pairs of ganglia) are removed. Recordings are made from identified neurons in the neural circuit for siphon and gill withdrawal. (D) The most intact preparation is the whole-mount preparation.

Lze studovat dokonce na tkáňové kultuře



(A)

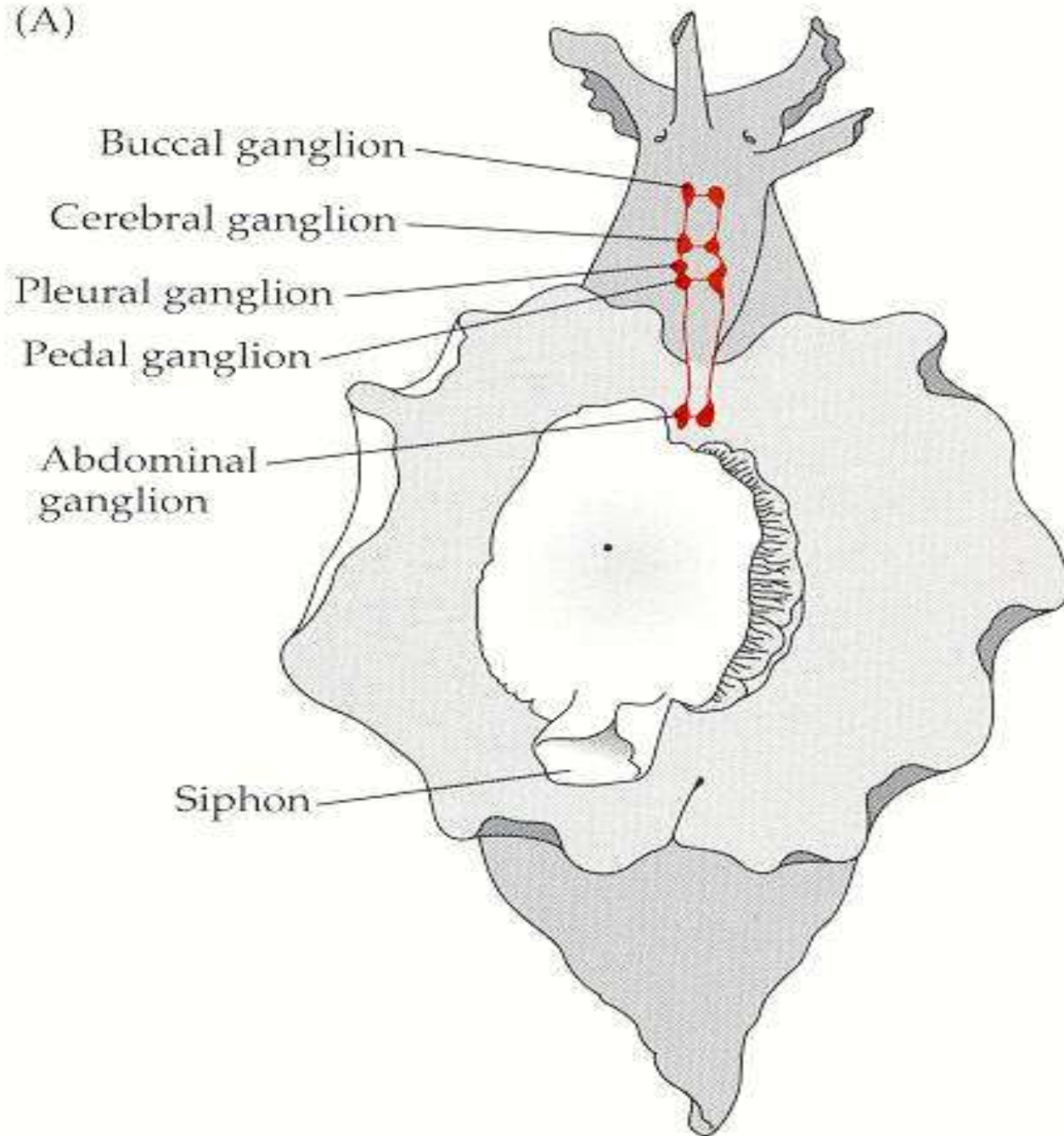

Habituace

- Každý dotek na sifon stále vyvolá akční potenciál, vylití mediátoru na synapsi a vznik postsynaptického potenciálu
- Každý AP vyvolává uvolnění méně mediátoru (glutamát) na motorický neuron
- Méně glutamátu způsobí pokles odpovědi motorického neuronu

SIFON

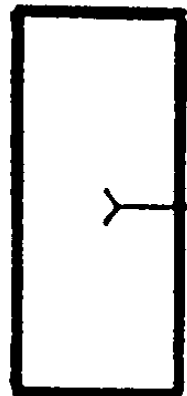

SN_s

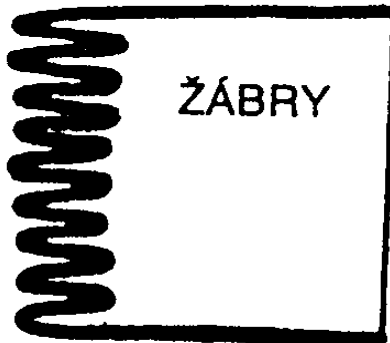

ŽÁBRY

SN_t

INT fac.

INT exc.

MN

OCAS

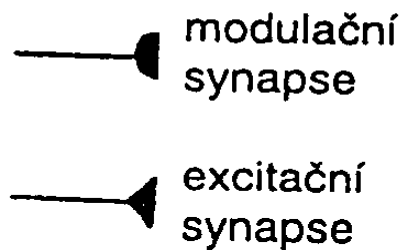

A. THE REFLEX BEHAVIOR

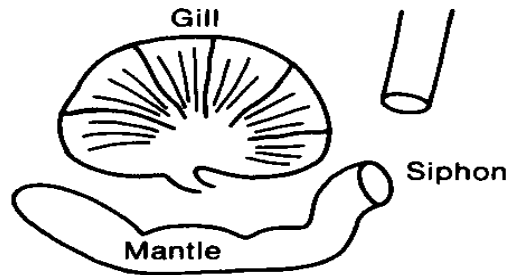

1. Normal, Unstimulated

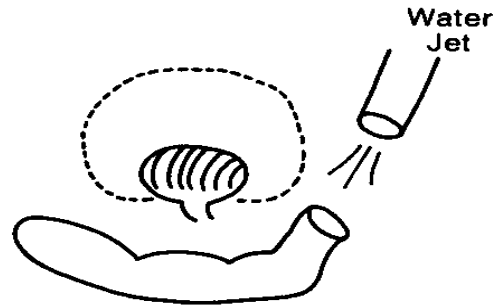

2. Initial Withdrawal

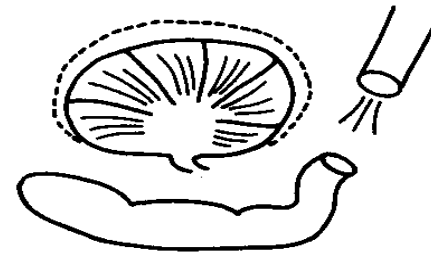

3. Withdrawal after Habituation

B. ELECTROPHYSIOLOGICAL ANALYSIS

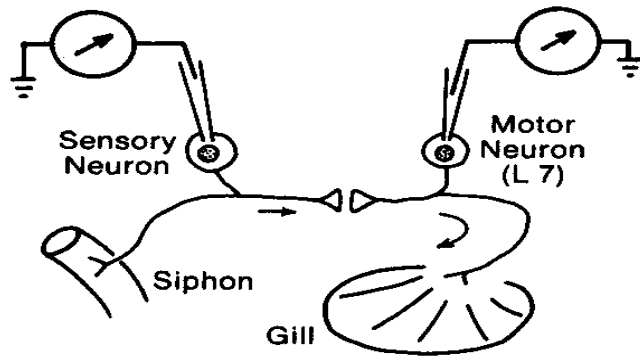

Experimental Set-up

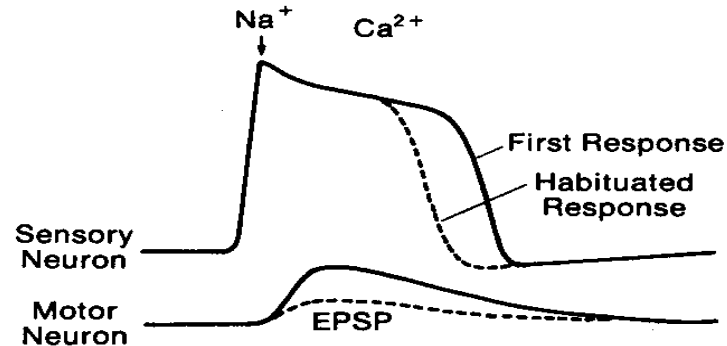

Recordings Before and After Habituation

Krátkodobá habituace díky inaktivaci Ca kanálů.

C. CONCEPTUAL MODELS

SHORT-TERM HABITUATION

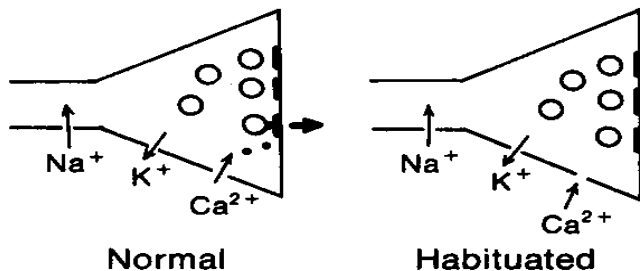

Normal

Habituated

LONG-TERM HABITUATION

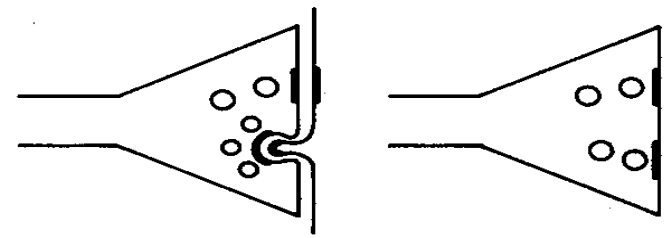

Normal

Habituated

Sensitizace

Sensitizace je **zvýšení** citlivosti organismu k opakovanému dráždění původně neutrálním podnětem následující po dráždivém podnětu

Když je podnět *nepravidelný*

Podnět *velké intenzity*

Představuje *celkové vybuzení, excitaci* organismu

Obyčejně je *krátkodobá*

SENSITIZACE U APLYSIA

Dotek na sifon...

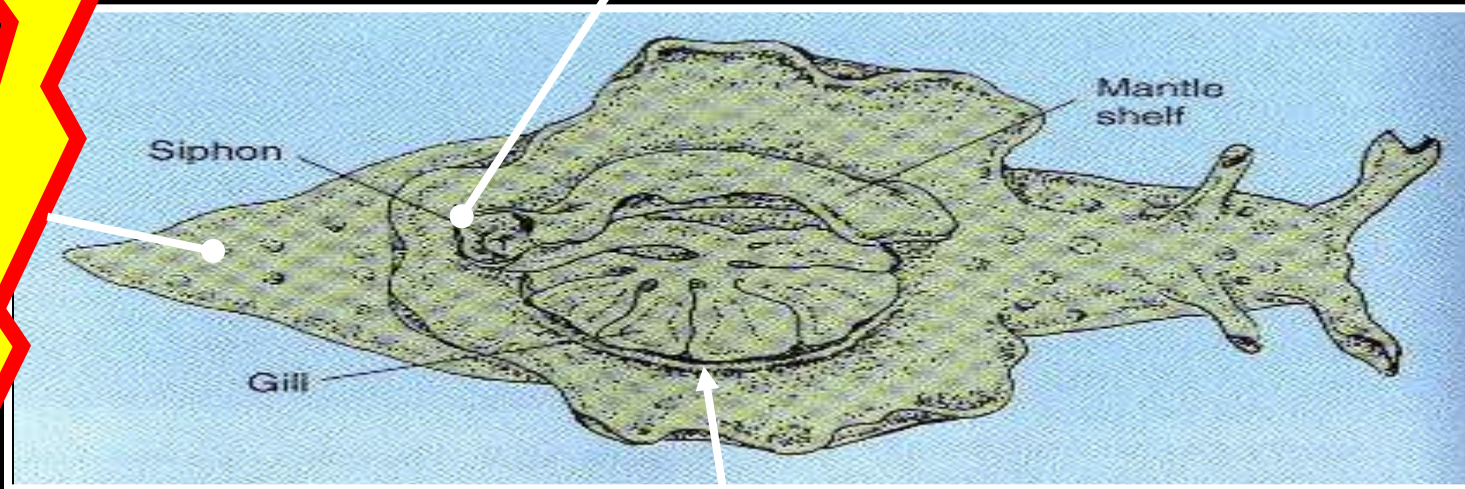

...a žábra se stáhnou

OBRANNÁ REAKCE STAŽENÍ ŽABER *APLYSIA*

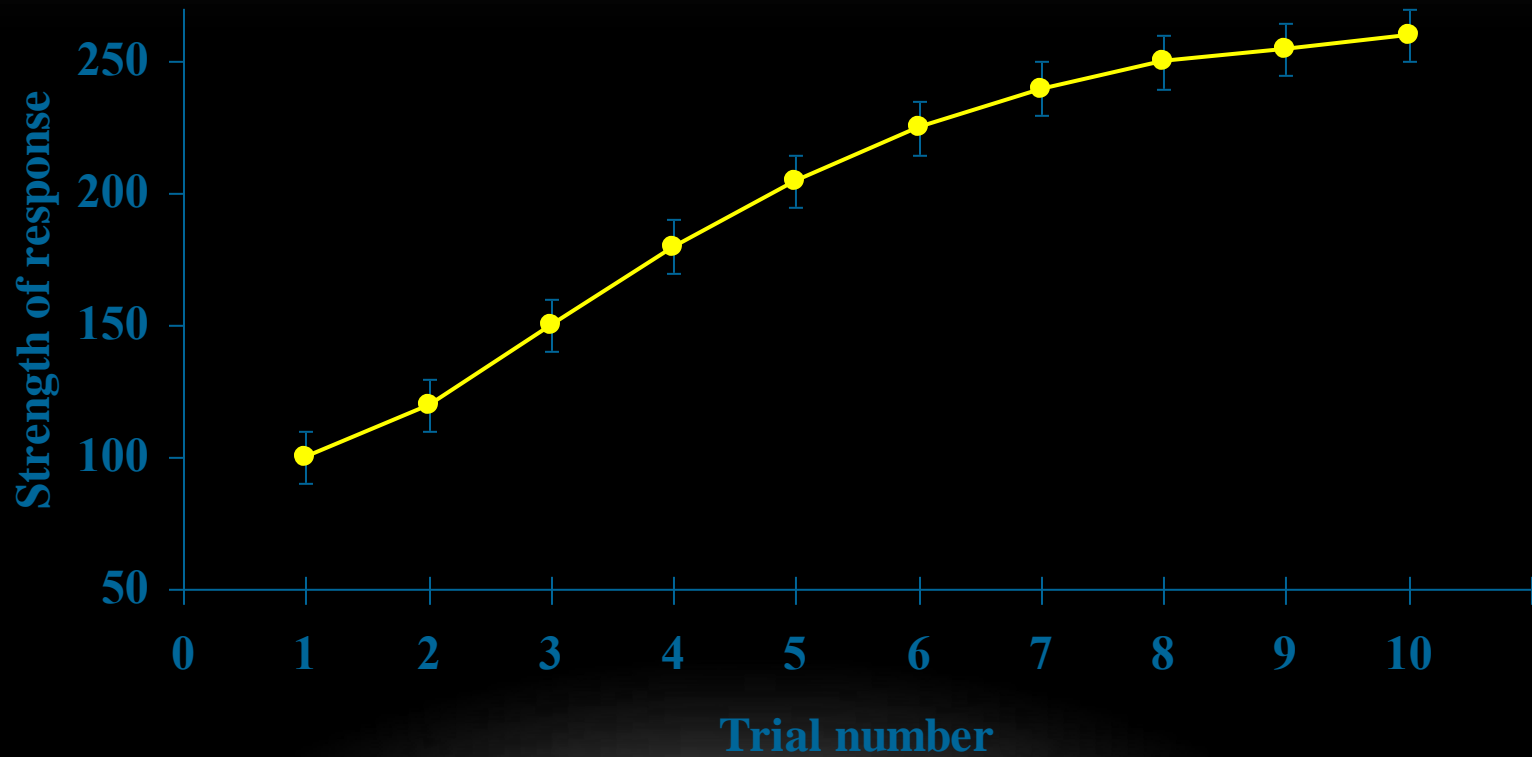

A. EXPERIMENTAL SET-UP DEMONSTRATING SENSITIZATION

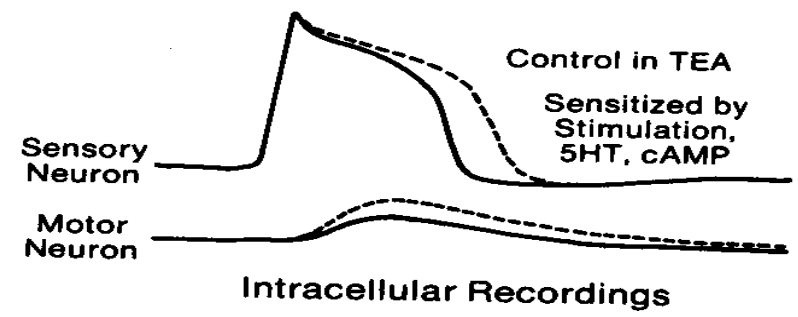
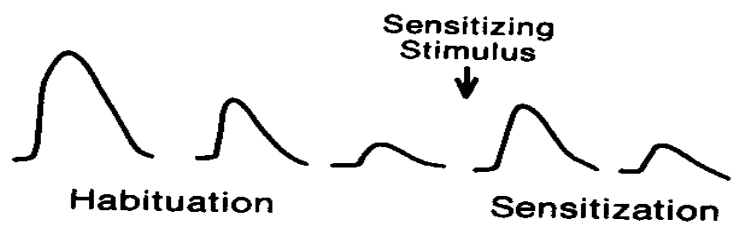
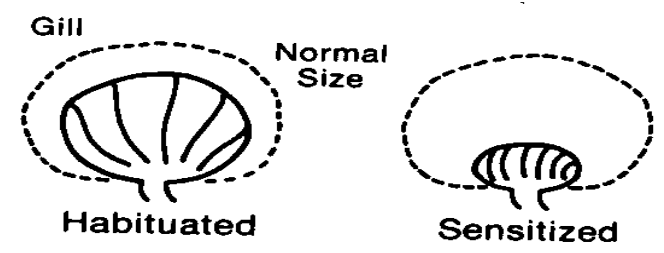
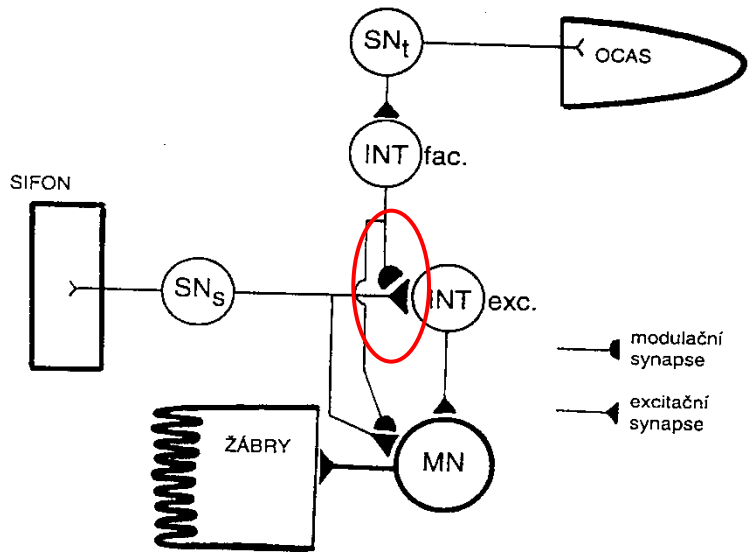

C. CONCEPTUAL MODELS

SHORT-TERM SENSITIZATION

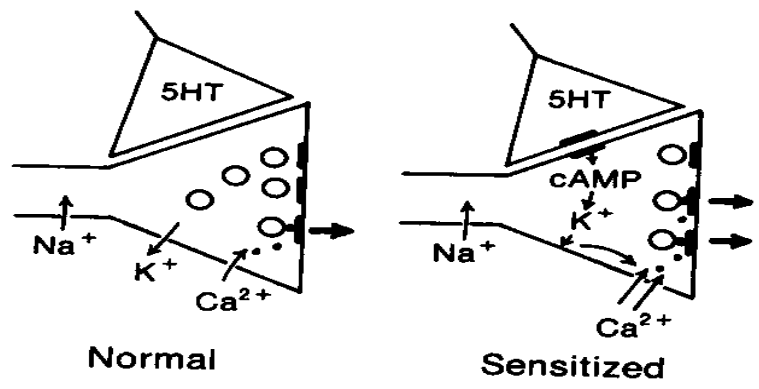

LONG-TERM SENSITIZATION

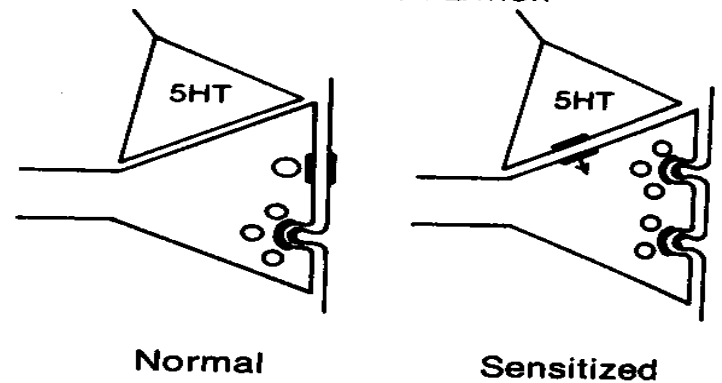

- - 5-HT difunduje synaptickou štěrbinou a váže se na serotoninové receptory na povrchu cytoplasmatické membrány presynaptických elementů sensorických neuronů SNs. Stimulovaný receptor prostřednictvím G-proteinu aktivuje membránový enzym adenylatcyklasu. Aktivovaný enzym začne z ATP vyrábět cAMP.
- - cAMP aktivuje cytoplasmatickou proteinkinasu. Stimulovaný enzym poté způsobí fosforylaci proteinu K⁺ kanálů v povrchové membráně presynaptických elementů sensorických neuronů SNs.
- - Fosforylace způsobí změnu konfigurace kanálového proteinu. Důsledkem toho je snížená vodivost K⁺ kanálů, pokles velikosti repolarizujícího K⁺ proudu a prodloužení trvání akčního potenciálu generovaného na membráně presynaptického elementu sensorických buněk SNs.
- - Delší trvání depolarizační fáze akčního potenciálu, které výše zmíněným mechanismem nastane, způsobí prolongované otevření napěťově závislých Ca²⁺ kanálů v povrchové membráně presynaptických elementů sensorických neuronů SNs. Díky tomu během akčního potenciálu vstupuje do jejich nitra větší množství Ca²⁺ iontů.
- - Vyšší koncentrace volných Ca²⁺ iontů v nervové terminále způsobí větší mobilizaci synaptických vesikul. To se projeví uvolňováním větších kvant mediátoru sensorickými buňkami SNs.
- - Aktivace většího množství postsynaptických receptorů vyšší koncentrací mediátoru v synaptické štěrbině způsobuje vzrůst amplitudy EPSP, a tím i frekvence akčních potenciálů na excitačních interneuronech a motorických buňkách.

Ad A) Krátkodobé zesílení

Fosforylace a snížená vodivost K kanálů. Zadržení K⁺ a delší depolarizace presynaptického elementu.

Delší otevření Ca kanálů a větší výlev mediátoru.

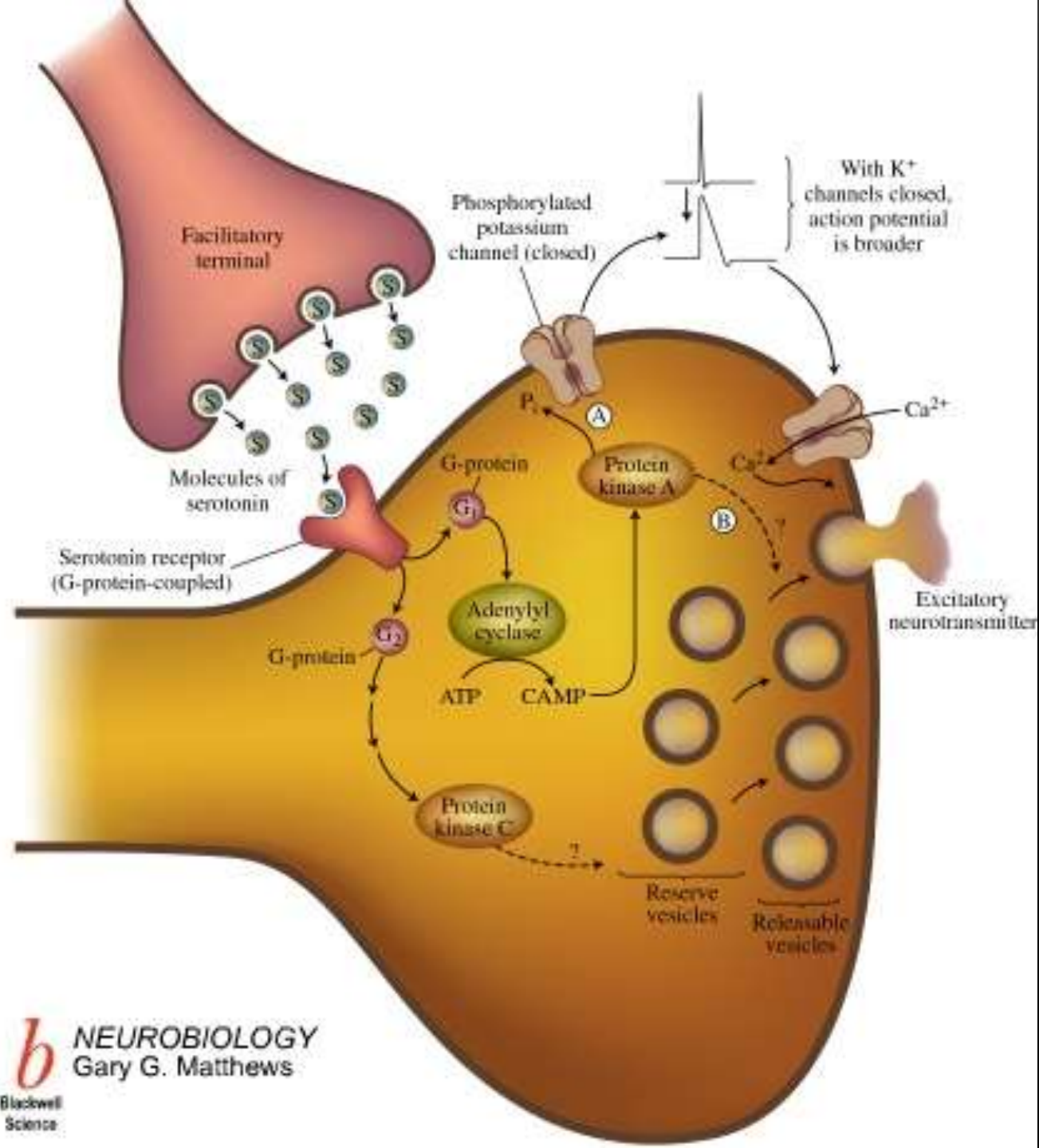

Ad A) Krátkodobé zesílení – 3 cesty:

3 Three molecular targets involved in presynaptic facilitation

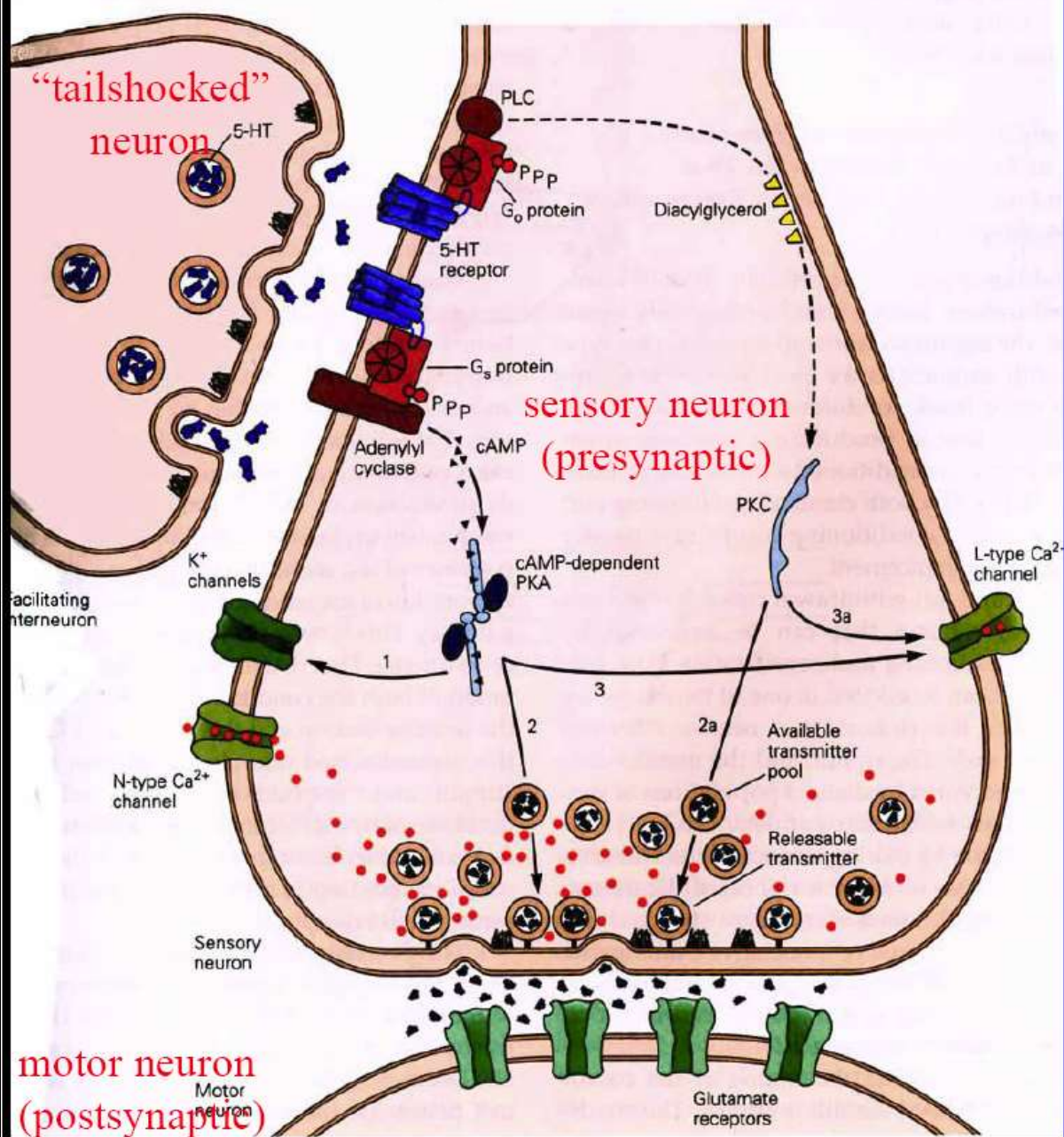

Serotonin acts on two receptors

G_s: cAMP -> **PKA**

G_o: DAG -> **PKC**

PKA (PKC)

1 decreases K⁺ current (longer AP, more Ca²⁺) phosphorylates channel

2/2a mobilizing vesicles, facilitating release

3/3a opening of Ca²⁺ channels

A) Krátkodobé zesílení zatahovacího reflexu (způsobené slabým podrážděním regulační synapse - vlevo), vyvolá krátkodobou fosforylaci iontových kanálů a větší výlev přenašeče.

B) Silnější a dlouhodobější dráždění způsobuje dlouhodobou fosforylaci a syntéza strukturních proteinů vyvolá morfologické zvětšení synapse a efekt většího výlevu zůstává trvalý.

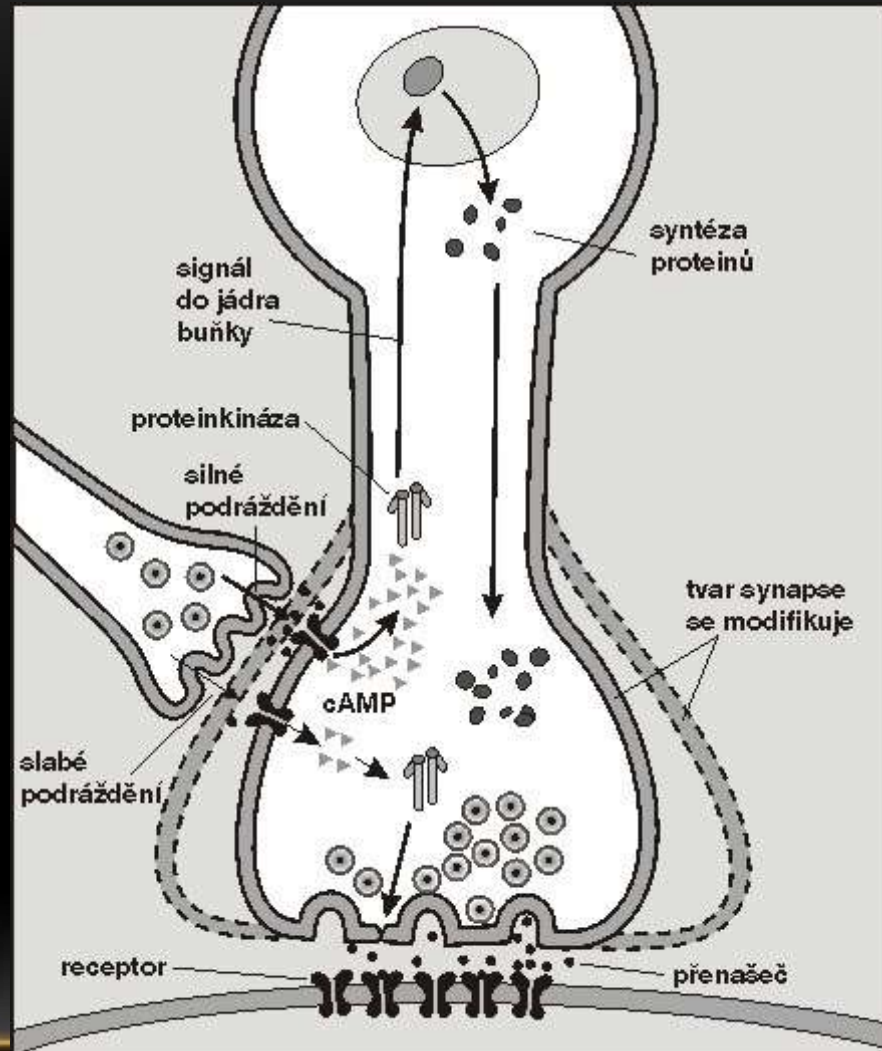

Ad B) Dlouhodobé dráždění aktivuje syntézu látek k přestavbě synapse.

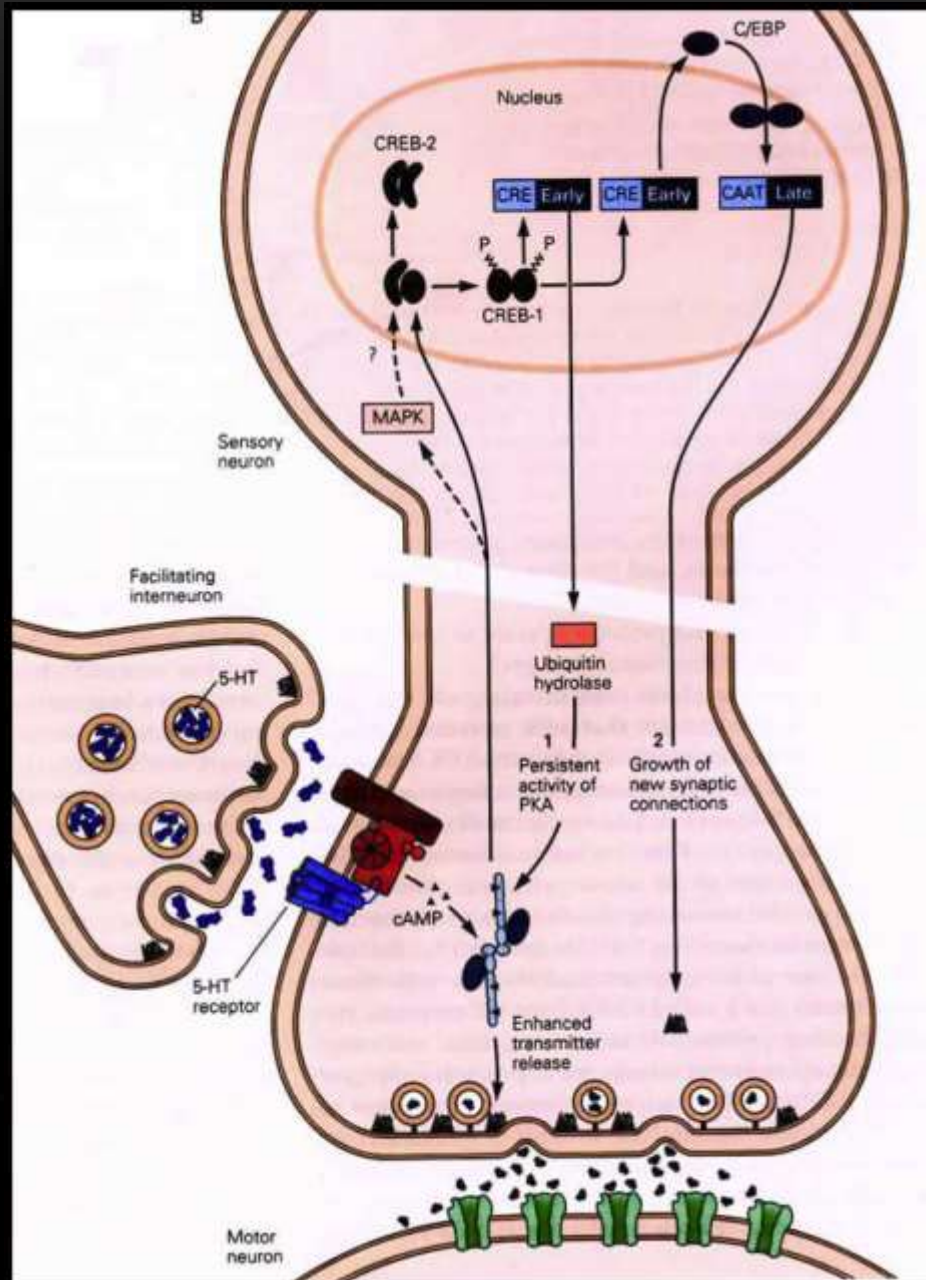

long-term sensitization/memory

persistent activity of sensory cell

a PKA+MAPK translocate to nucleus

a PKA phosphorylates CREB-1 (activator of transcription)

a MAPK inhibits CREB-2 (inhibitor of transcription)

a Ubiquitin hydrolases proteolyzes regulatory PKA subunit

a PKA persistently active

Sensitization Produces Both Pre- and Postsynaptic Structural Changes in the Intact Animal (HRP)

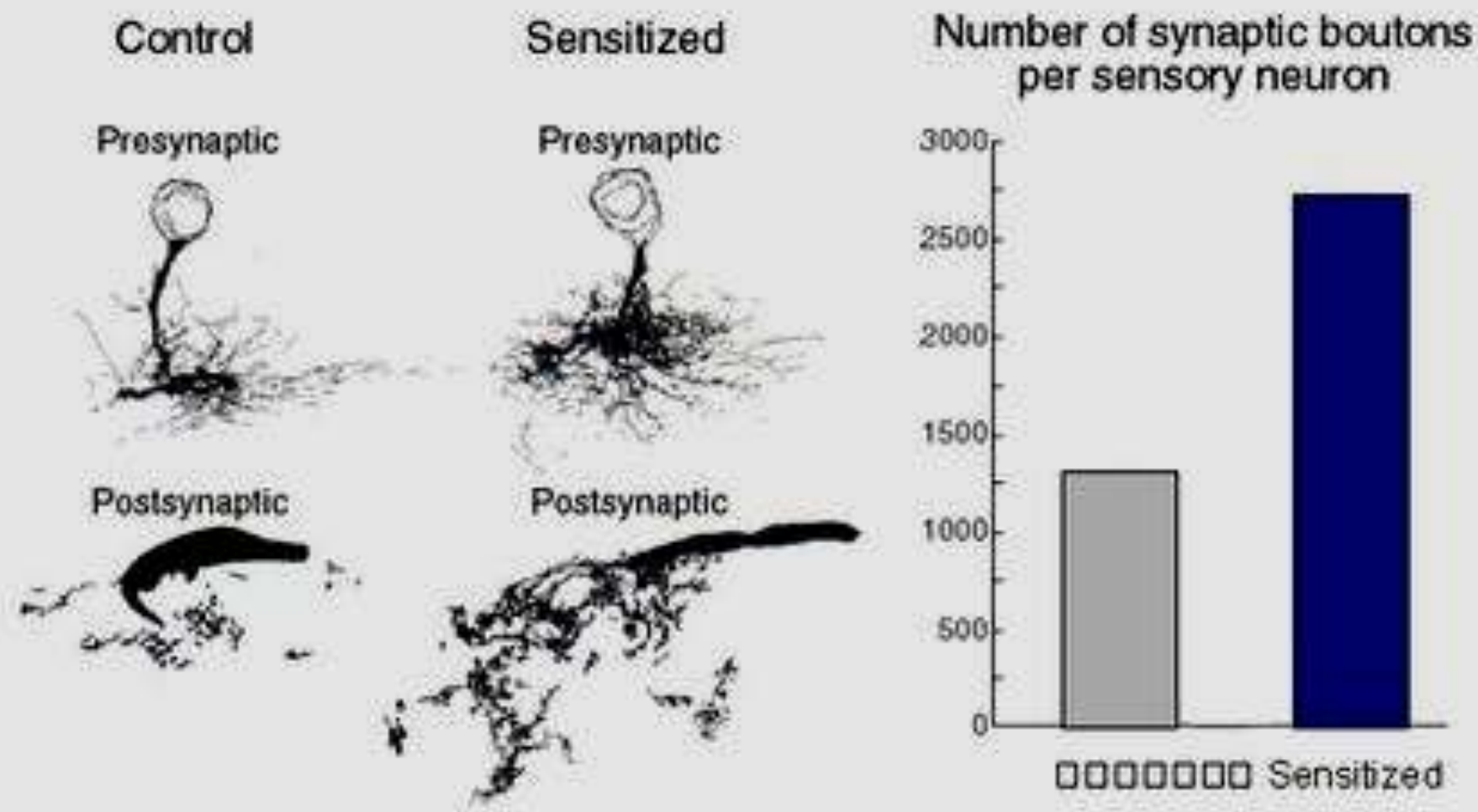

Asociativní učení

- Vzniká spoj (asociace) dvou různých podnětů

1. Klasické podmiňování

- **Nepodmíněný podnět a indiferentní podnět**

2. Instrumentální (operantní) podmiňování

- **Nepodmíněný podnět a vlastní aktivita živočicha**

Podmiňování

(A)



(B)

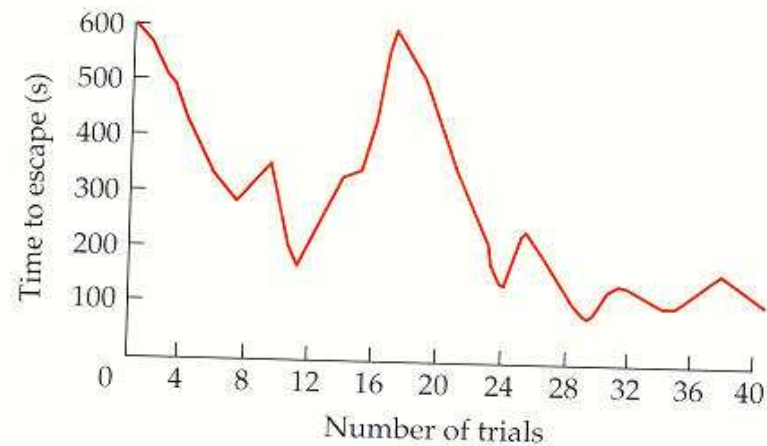
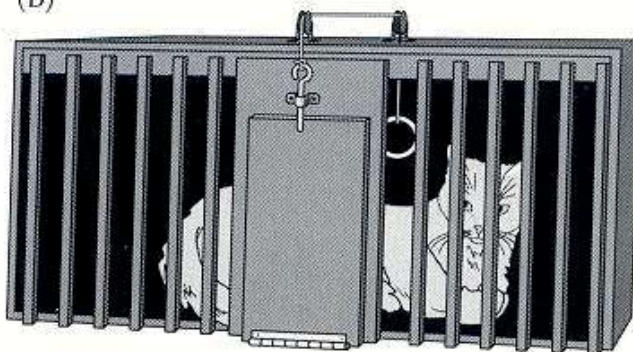

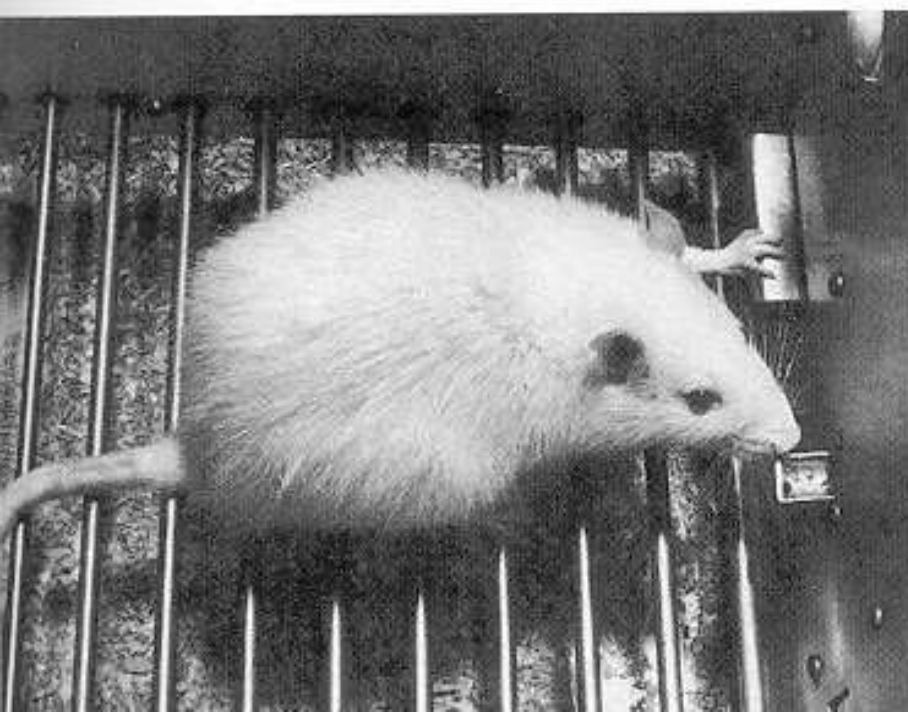
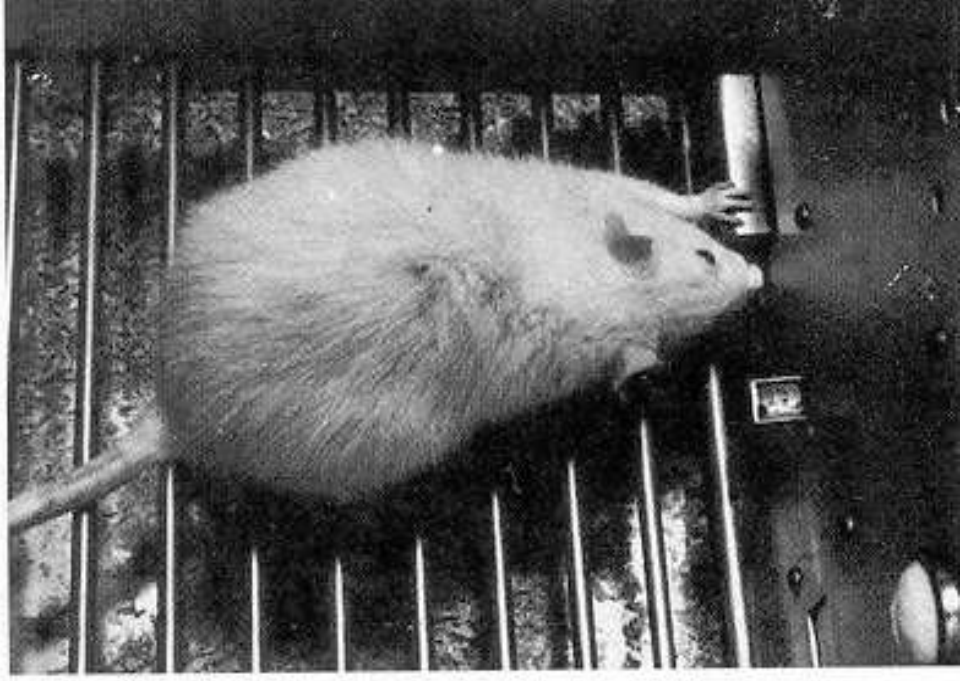
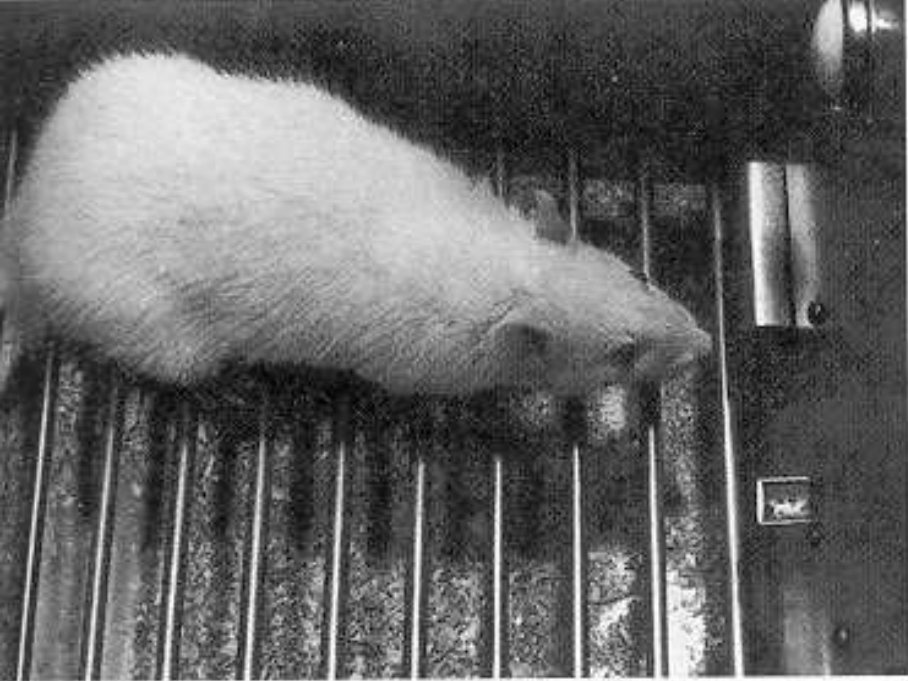

Podmiňování

Podmiňování zřejmě také využívá mechanismus presynaptického zesílení při synchronní a opakované aktivaci PP a NP. Ideálně současně nebo PP těsně před NP. Adenyl cykláza slouží jako koincidenční detektor.

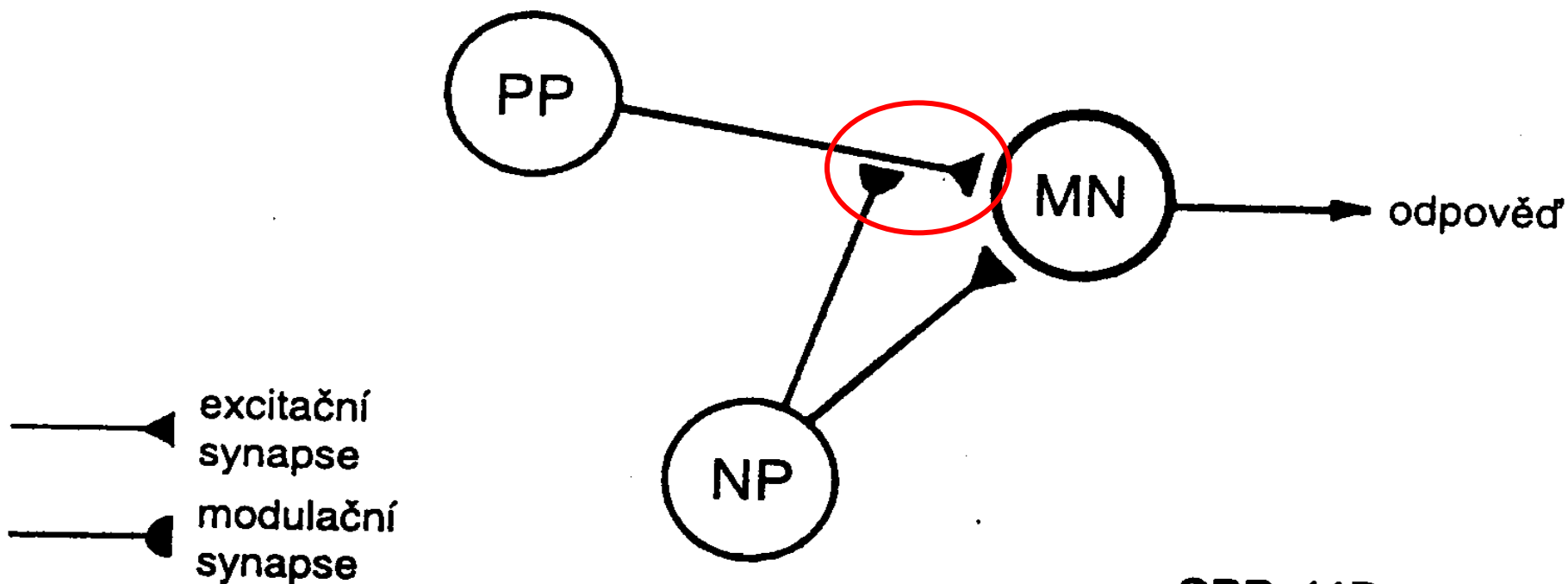

Aktivačně závislá neuromodulace

PP - Podmíněný podnět

NP – Nepodmíněný podnět

Důležité je pořadí, ale i načasování podnětů
V klasickém uspořádání PP lehce předchází NP (odměna nebo trest)

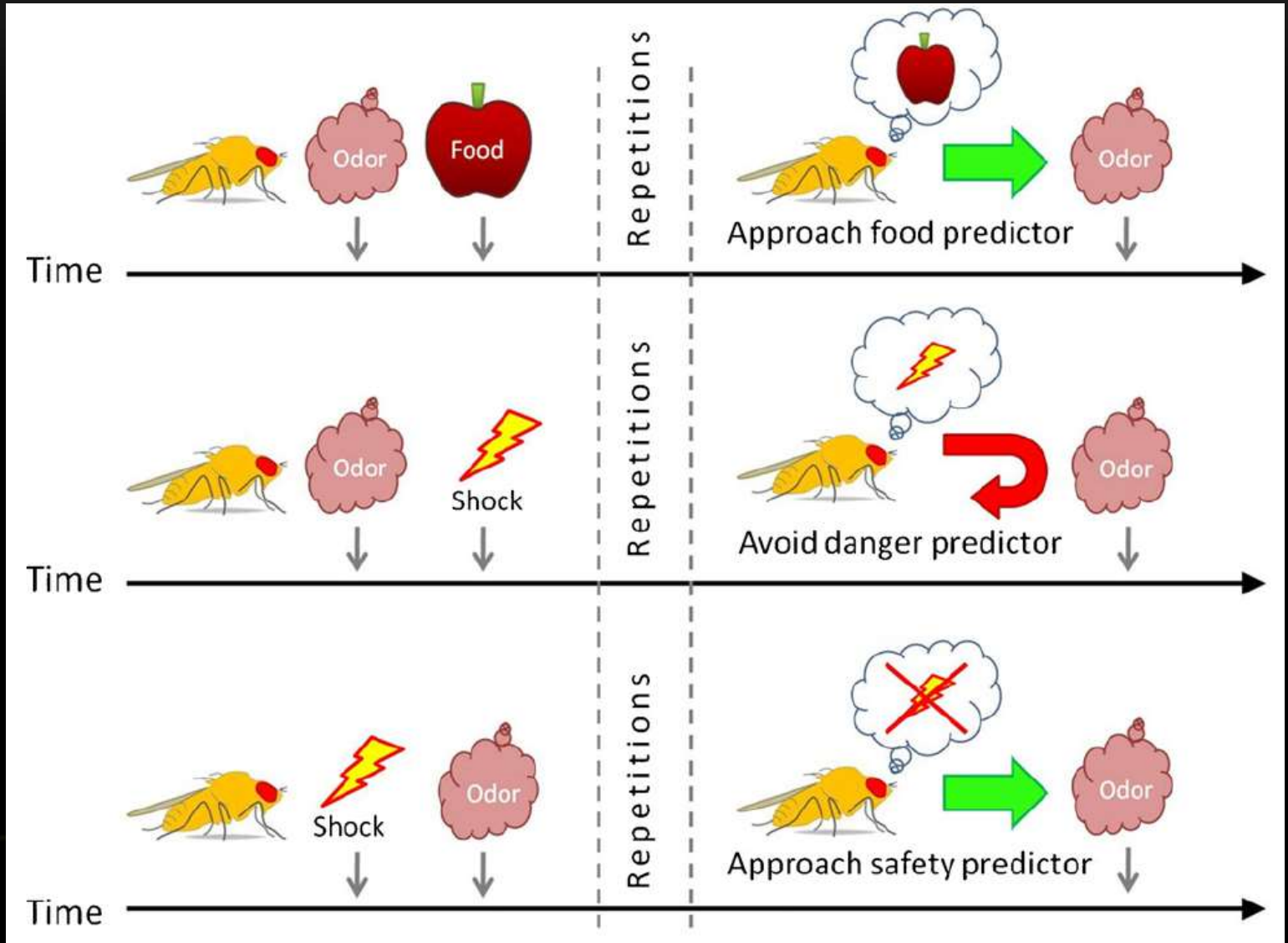

- Do posílení synapse nezasahuje jen modulační synapse. Nutná je spolupráce obou drah. Důležité pořadí a načasování PP a NP.
- Adenylcykláza je citlivá na Ca. Ca se nahromadí při aktivaci PP dráhy.
- Stimulace PP neuronu současně s (nebo těsně před) začátkem aktivace NP buňky má za následek influx Ca^{2+} iontů do cytoplasmy jeho presynaptického elementu. Ca^{2+} ionty se zde vážou na regulační protein calmodulin. Vzniklý **komplex Ca^{2+} - calmodulin se připojuje na adenylatcyklasu a zesílí její činnost**. Díky tomuto zásahu pak dochází k syntéze většího množství cAMP při působení modulačního mediátoru (5-HT) než při absenci Ca^{2+} - calmodulinového komplexu.
- Další působení molekul cAMP je jako v sensibilizaci

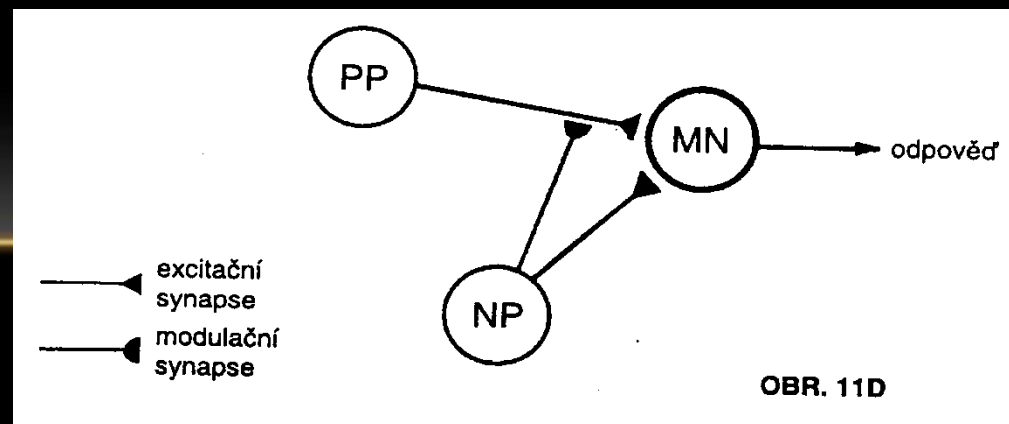

Koincidenční detekce:
Adenyl cykláza je aktivovaná jak alfa podjednotkou G proteinu, tak komplexem Ca Calmodulin.

1. Po aktivaci PP zvýšená hladina Ca^{2+}
2. Aktivace kalmodulinu
3. Kalmodulin stimuluje adenylcyklasu
4. Vyšší hladina cAMP
5. Serotonin z modulační s. také stimuluje ACyklázu

6. cAMP aktivuje PKA
7. Blokace K^{+} kanálů
8. Delší depolarizace
9. Delší influx Ca^{2+}
10. Větší výlev mediátoru

(B) Classical conditioning

CS+ PATHWAY (preceding activity)

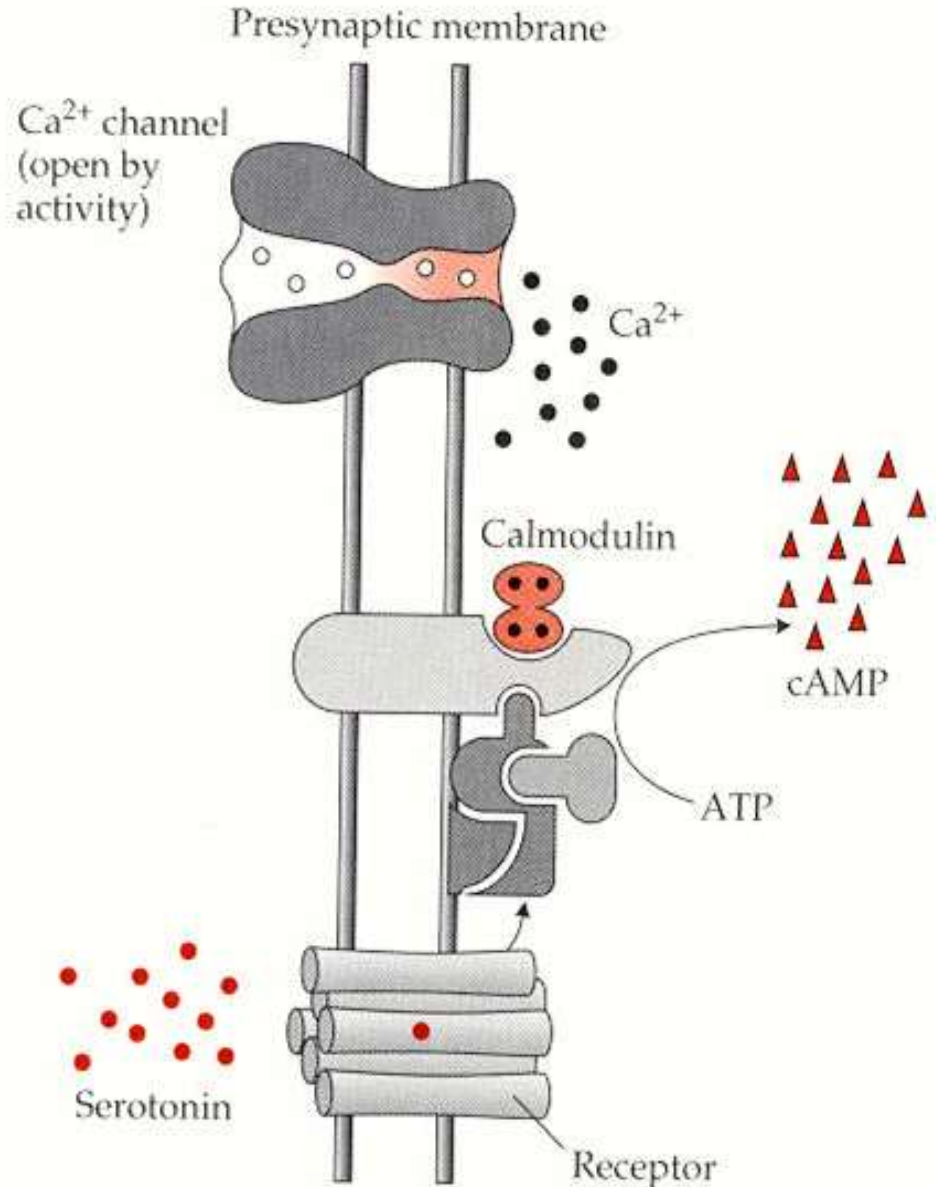

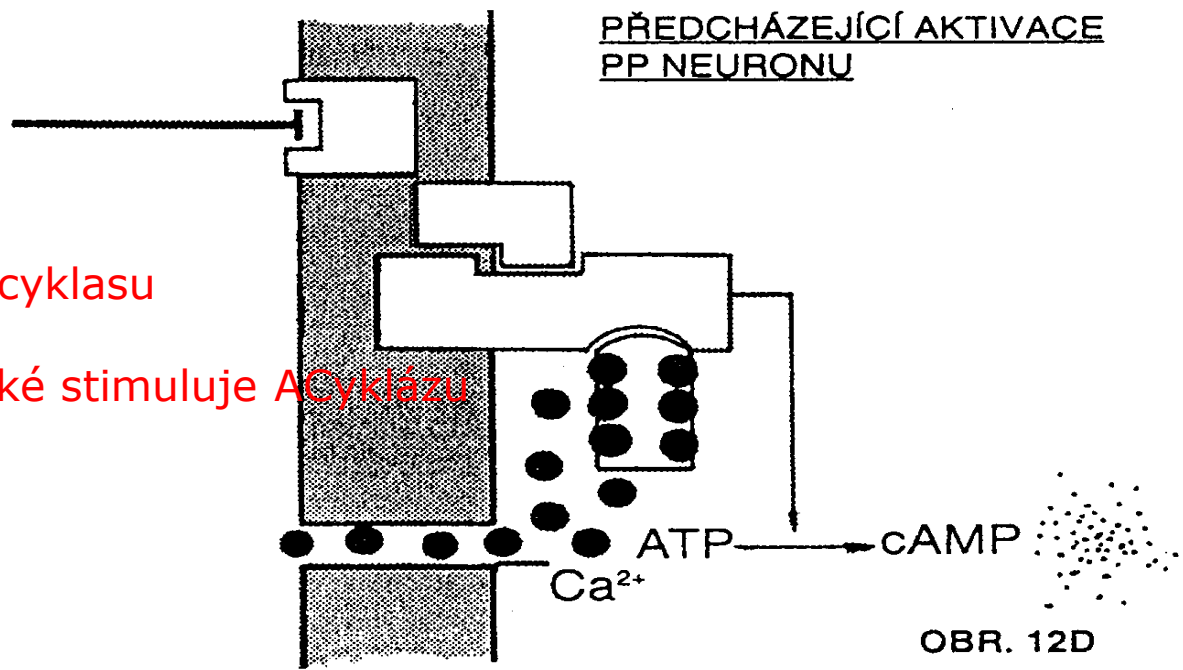
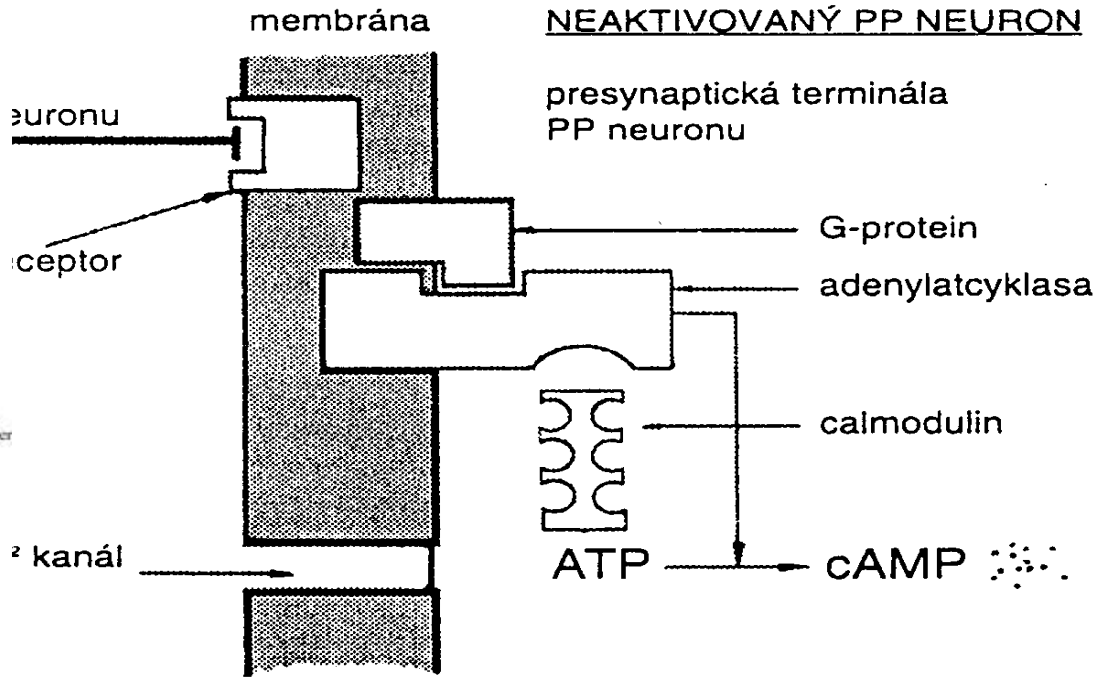
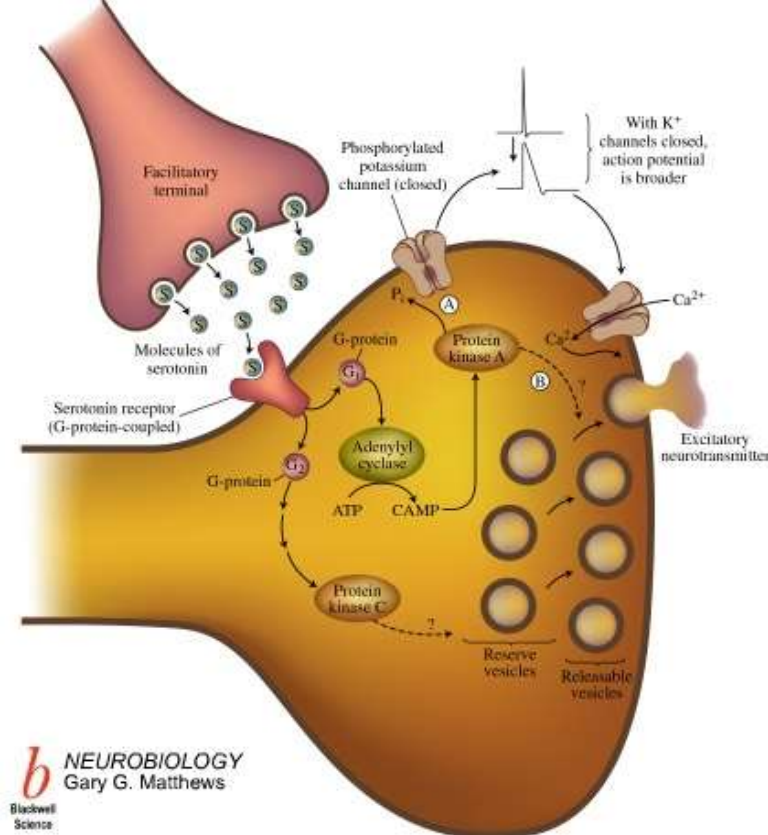

1. Po aktivaci PP zvýšená hladina Ca⁺
2. Aktivace kalmodulinu
3. Kalmodulin stimuluje adenylylcyklasu
4. Vyšší hladina cAMP
5. Serotonin z modulační s. také stimuluje ACyklázu
6. cAMP aktivuje PKA
7. Blokáce K⁺ kanálů
8. Delší depolarizace
9. Delší influx Ca⁺
10. Větší výlev mediátoru

Classical conditioning

A Unpaired pathway (ICS⁻)

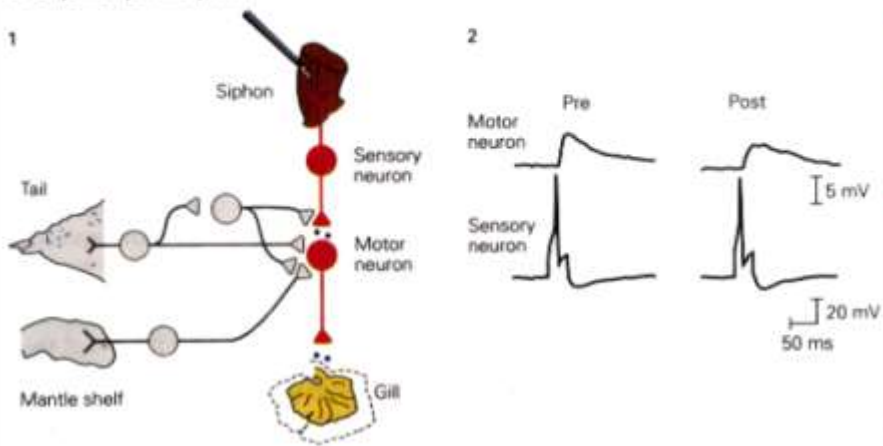

B Paired pathway (ICS⁺)

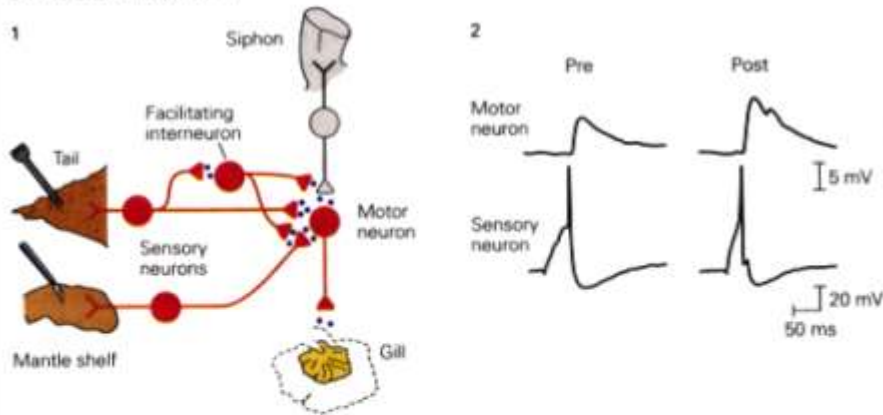

C Training protocol

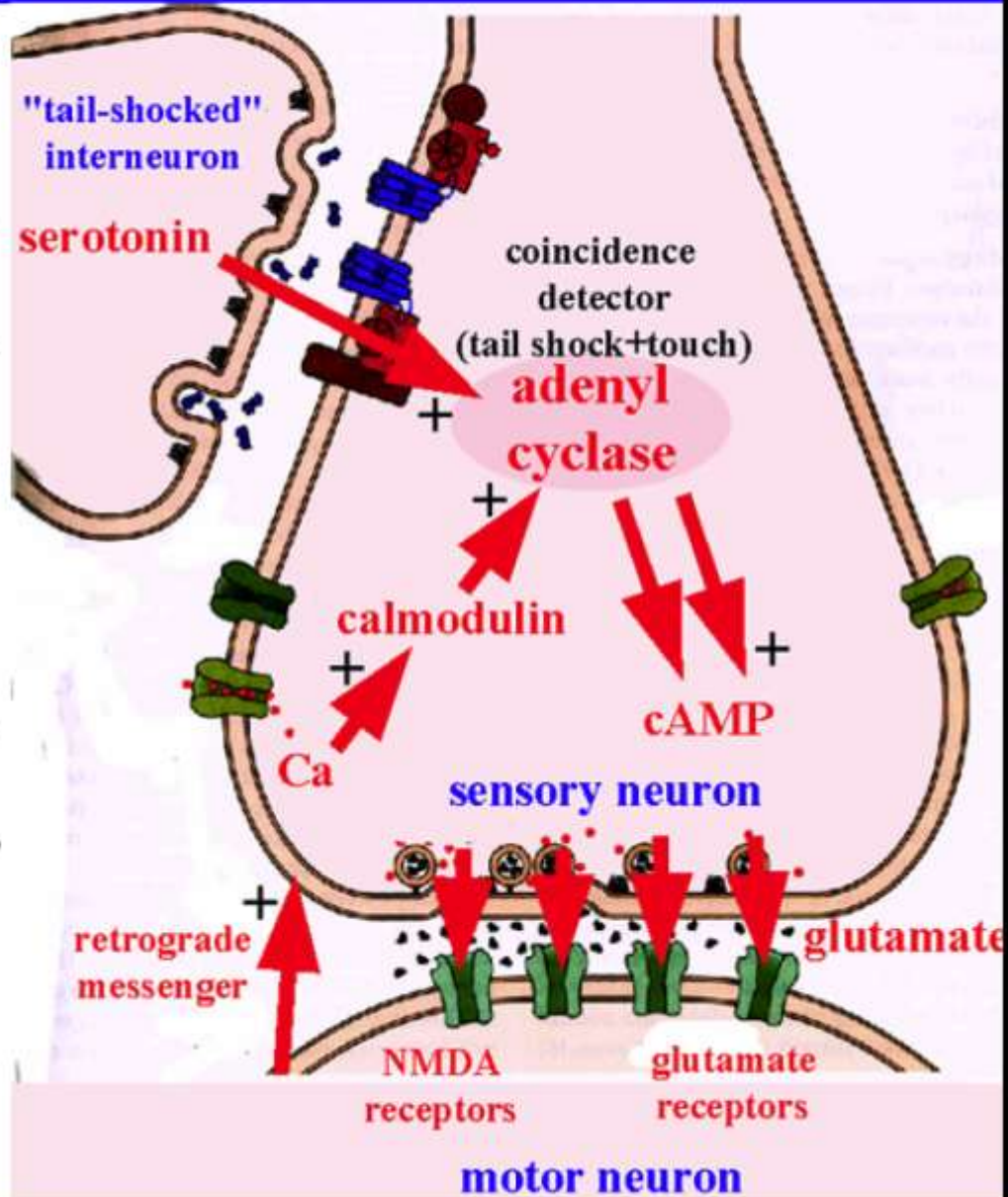
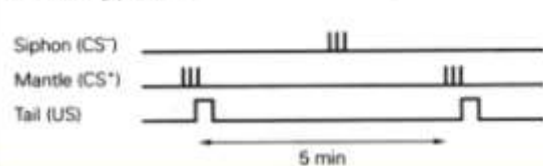

Koincidenční detekce u plže stejně jako u Drosophily

coincidence detection

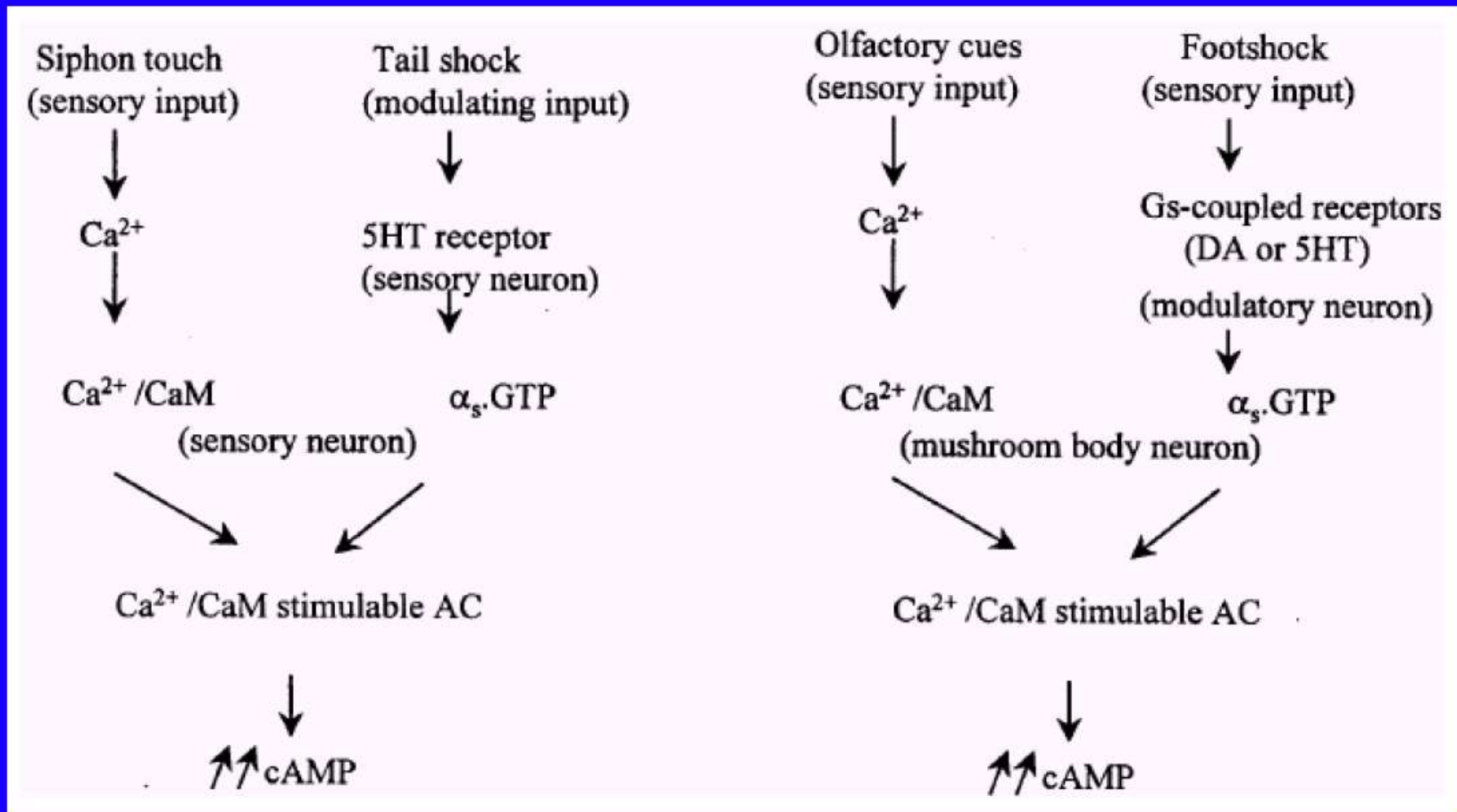

Depolarization of the sensory neurons prior to exposure to 5HT increases levels of cAMP over those seen when CS and US are unpaired. It has been suggested that Ca^{2+} influx resulting from CS could converge upon Ca^{2+} -calmodulin sensitive-AC and increase the cAMP level produced by 5HT. In this case, the *Aplysia* adenylyl cyclase is activated by both Ca^{2+} -calmodulin and GTPGs (a GTP analog that acts by binding to α_s), and therefore acts as a coincidence detector that is sensitive to the timing and order of stimuli.

Propojené dráhy krátkodobé a dlouhodobé paměti.

Krátkodobá: inaktivace K kanálů

Dlouhodobá: přestavba presynaptické části

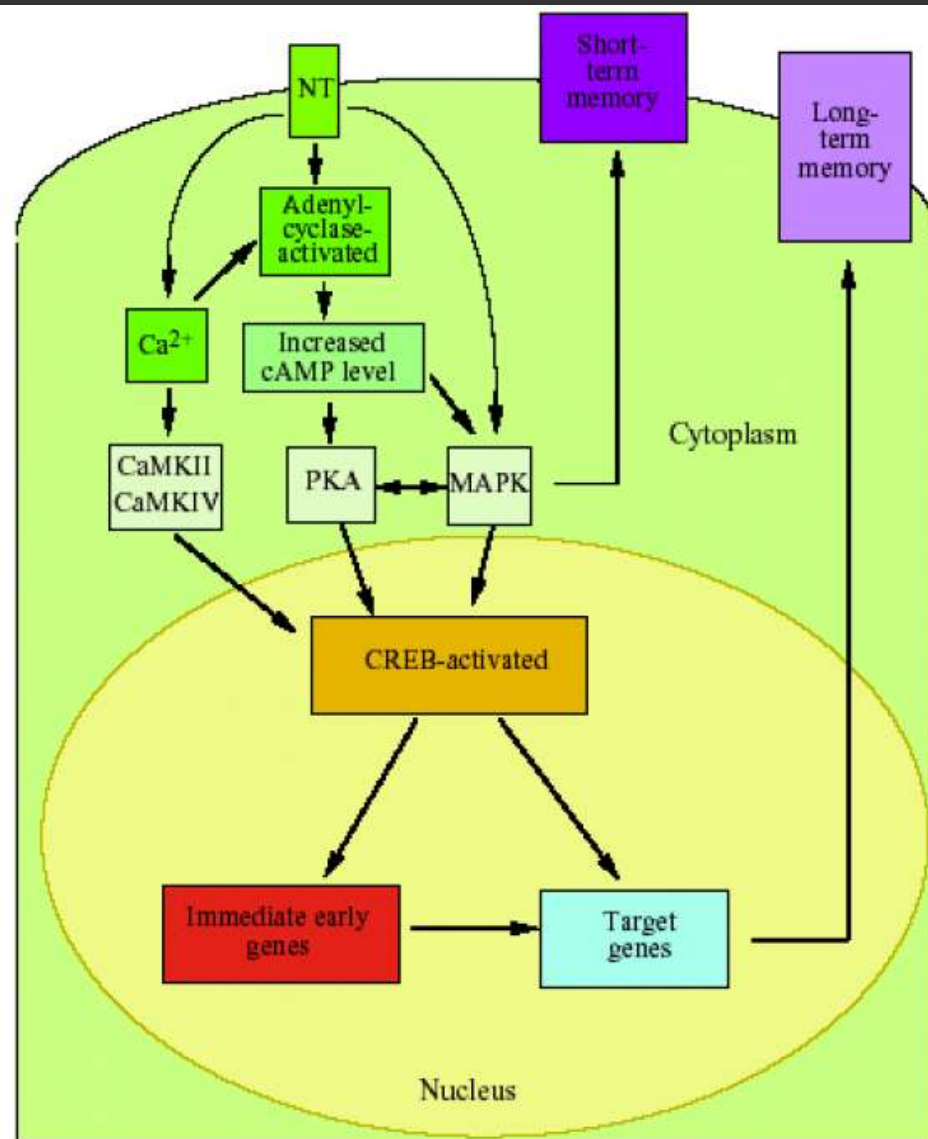
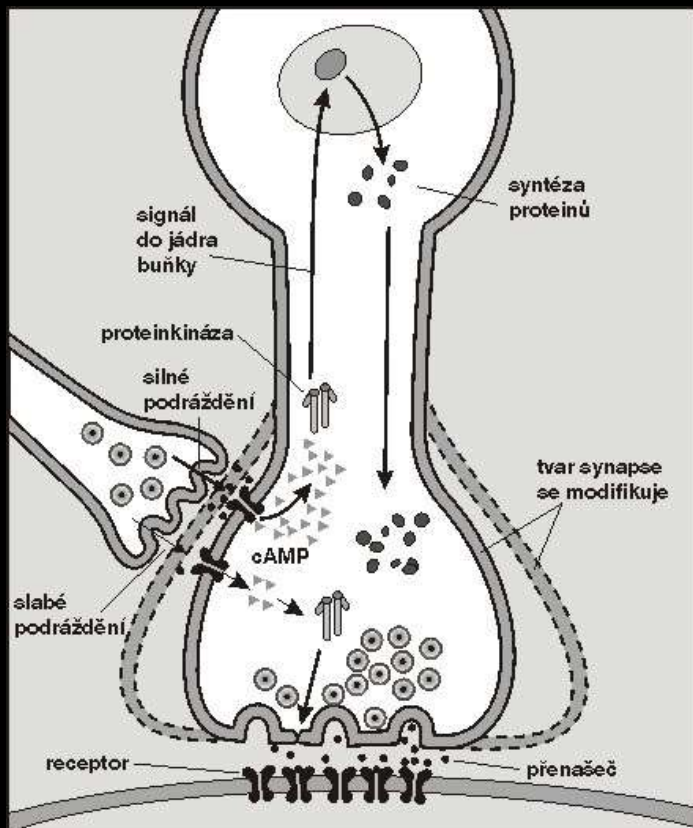
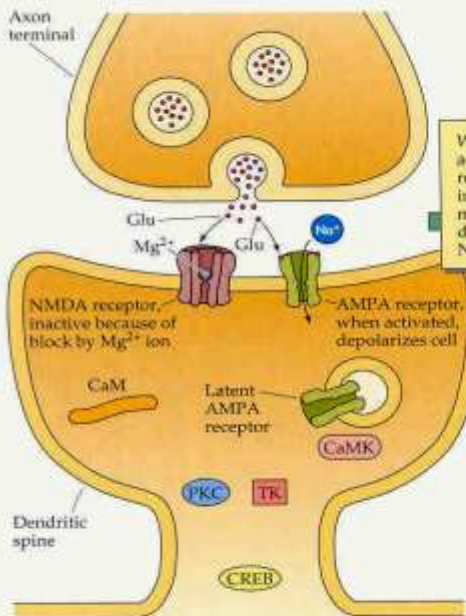

Fig. 1. Schematic representation summarizing the molecular events leading to short and long-term memory. CaMKII, CaMKIV, calcium-calmodulin-dependent kinases II and IV; CREB, cAMP response element binding protein; MAPK, mitogen activated protein kinase; PKA, cAMP-dependent protein kinase; NT, neurotransmitter.

Přestavba při podmiňování i na postsynaptické části

(a) Normal synaptic transmission



(b) Induction of LTP

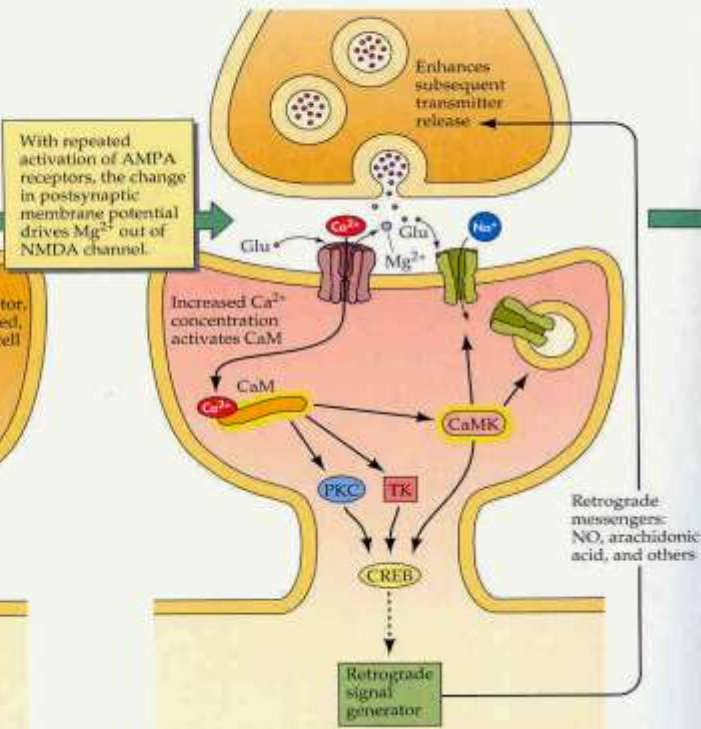

(c) Enhanced synapse, after induction of LTP

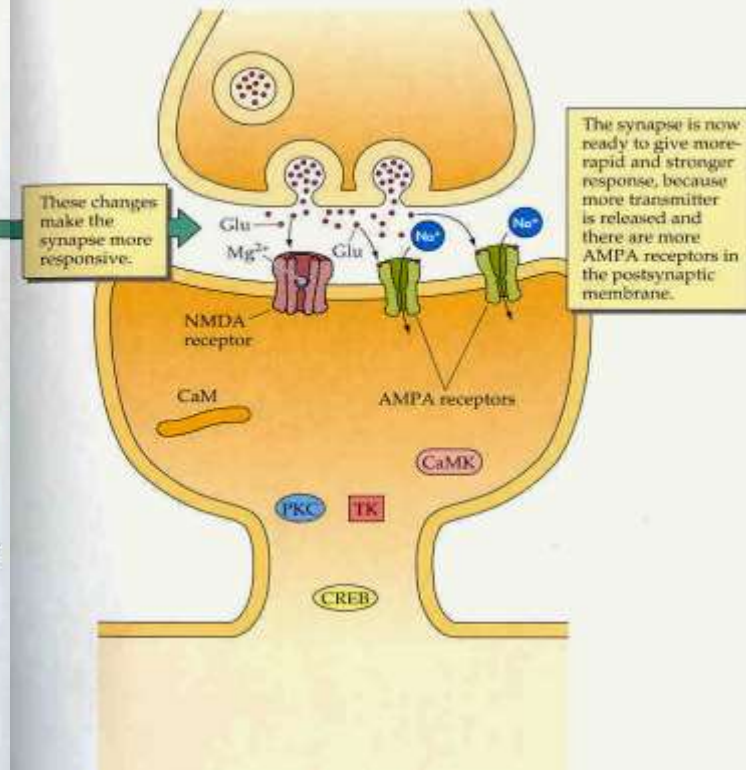

Přestavba pre i postsynaptické části synapsí

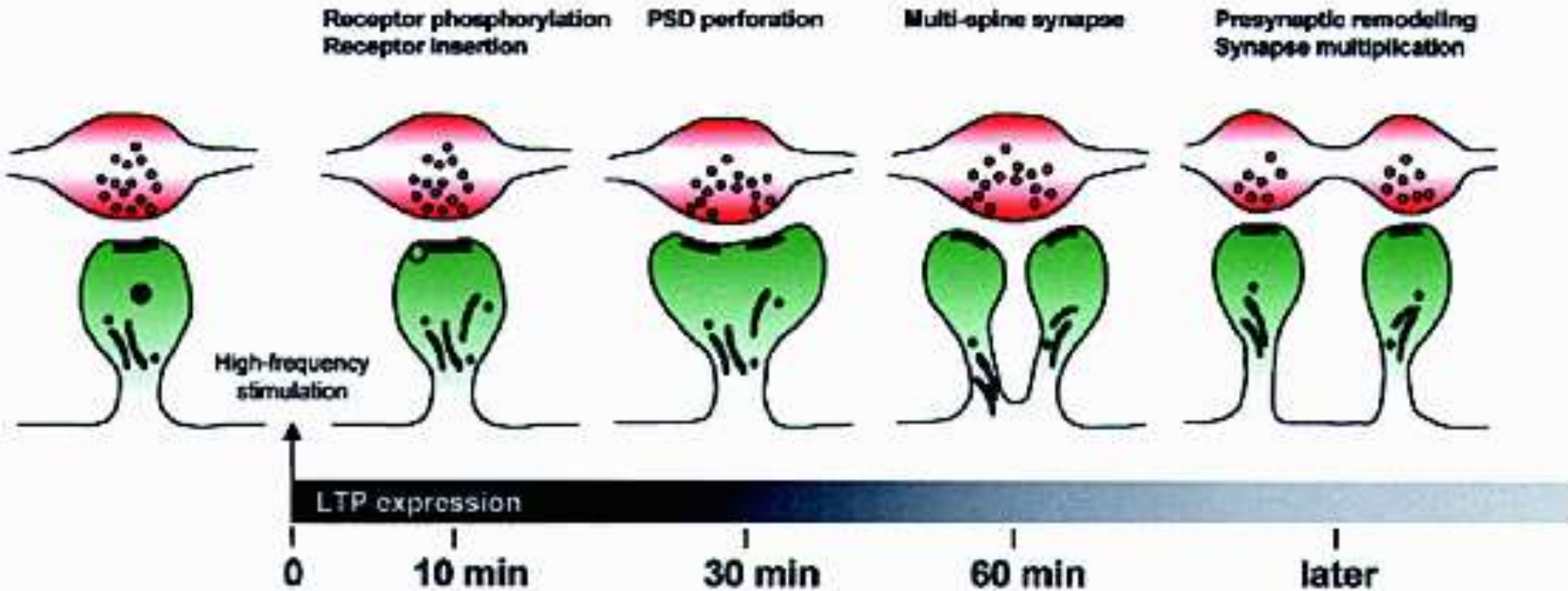

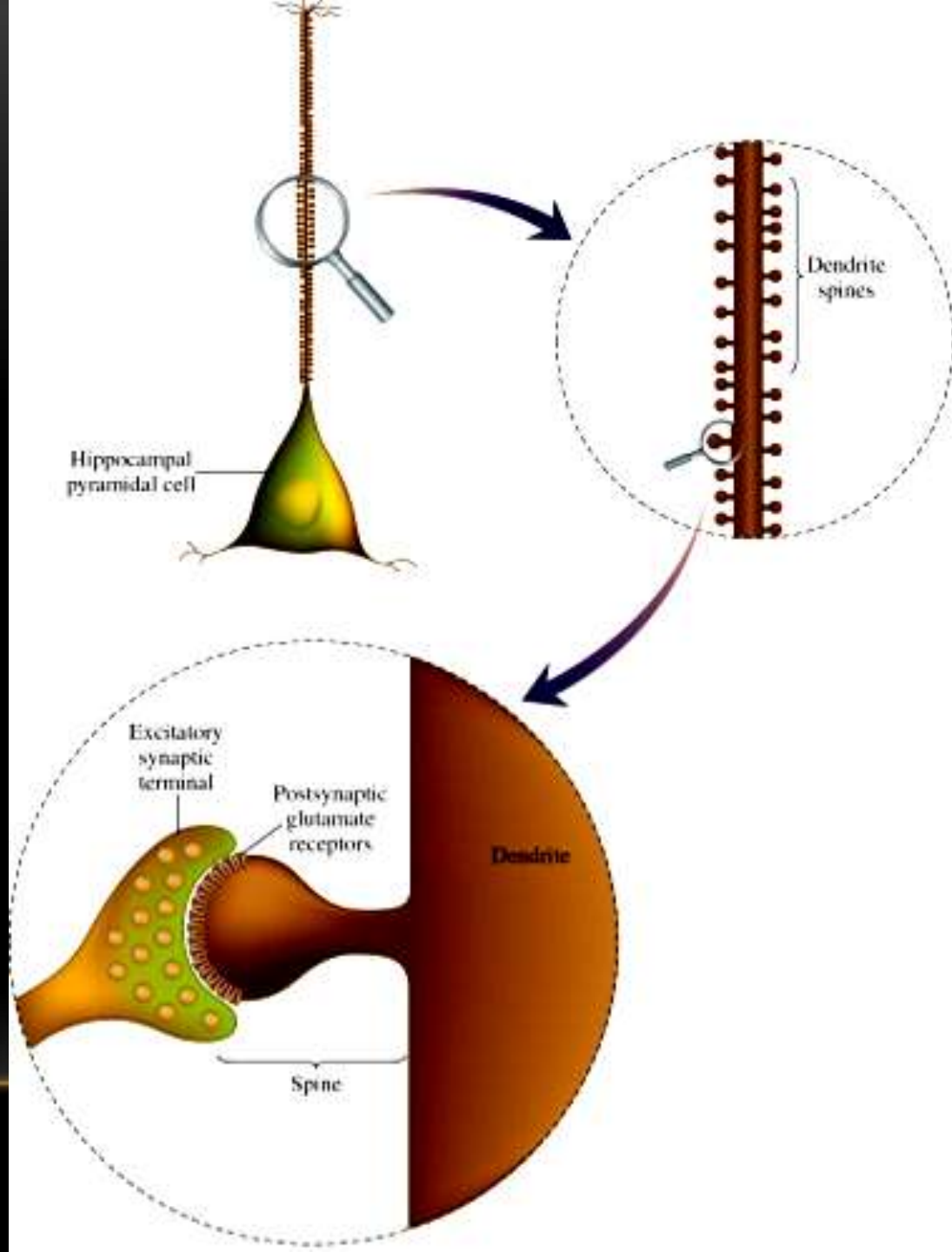

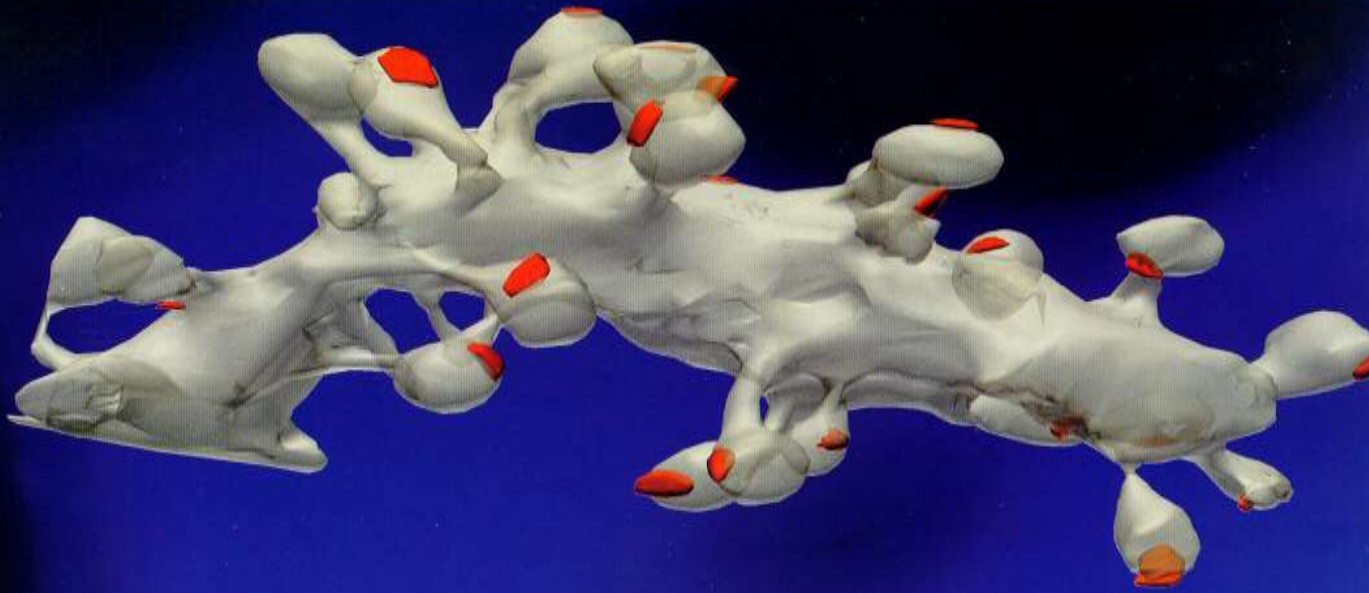

A. PROJECTION NEURONS



Olfactory
Receptor
Cell

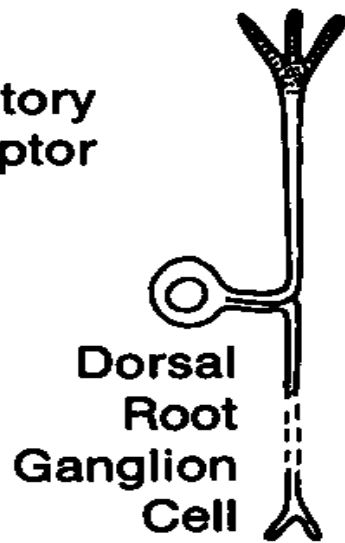

Dorsal
Root
Ganglion
Cell

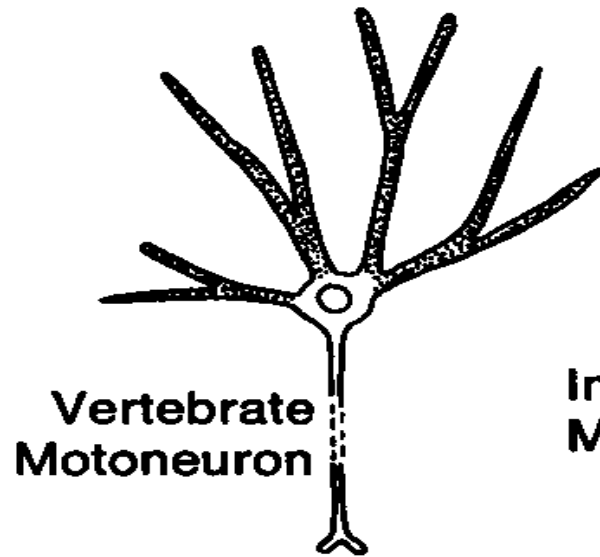

Vertebrate
Motoneuron

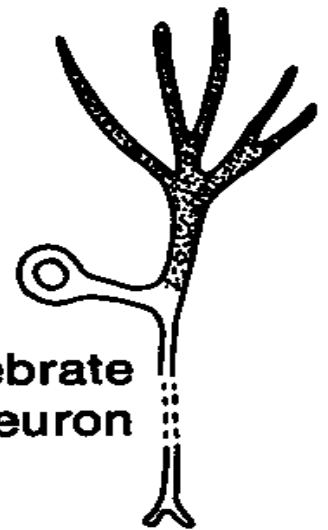

Invertebrate
Motoneuron

B. INTRINSIC NEURONS



Auditory
Hair Cell

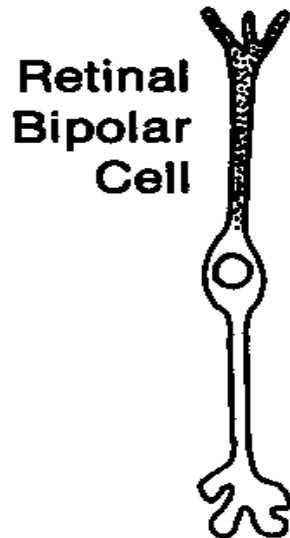

Retinal
Bipolar
Cell

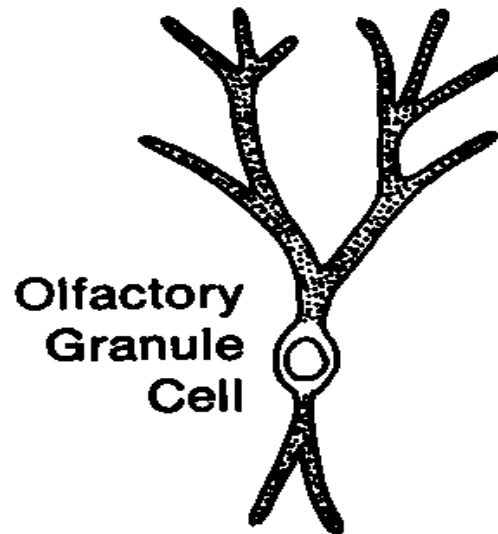

Olfactory
Granule
Cell

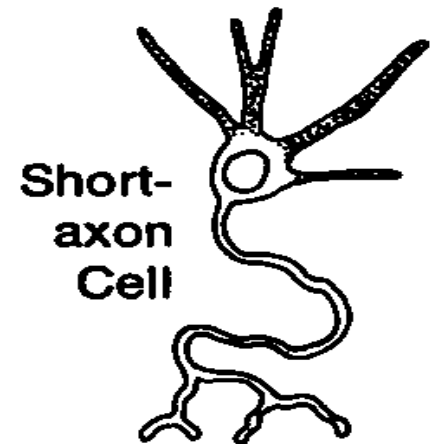

Short-
axon
Cell

