

Elektromigrační metody

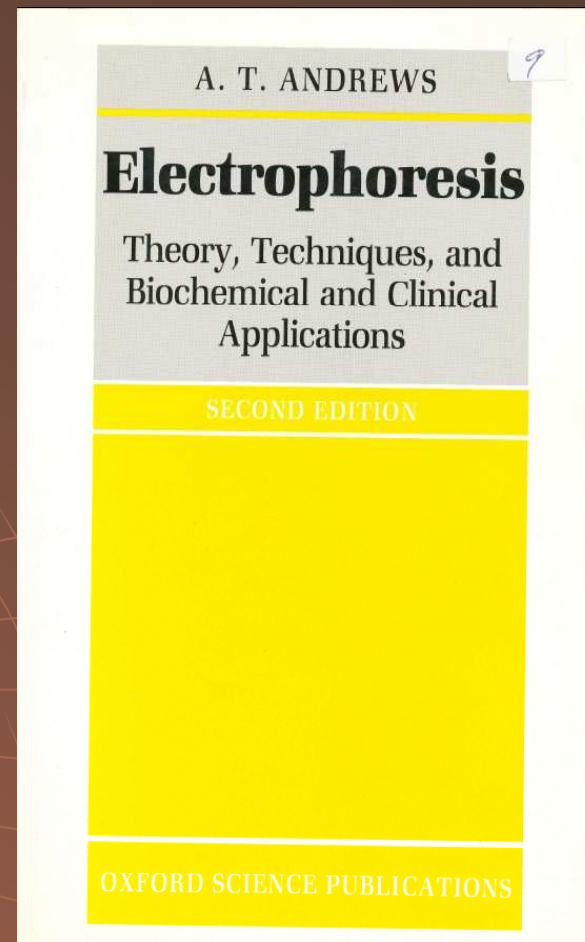

INVESTICE DO ROZVOJE VZDĚLÁVÁNÍ

Literatura

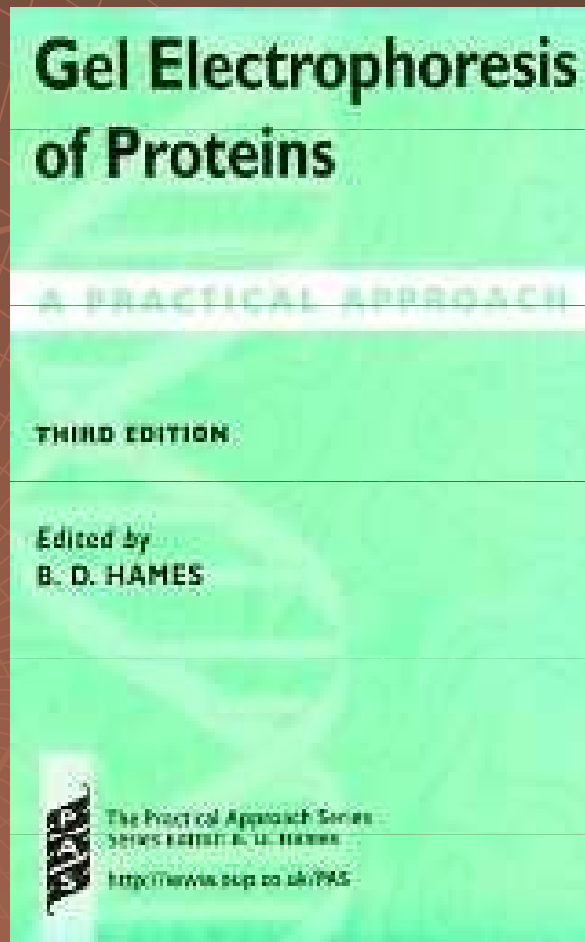
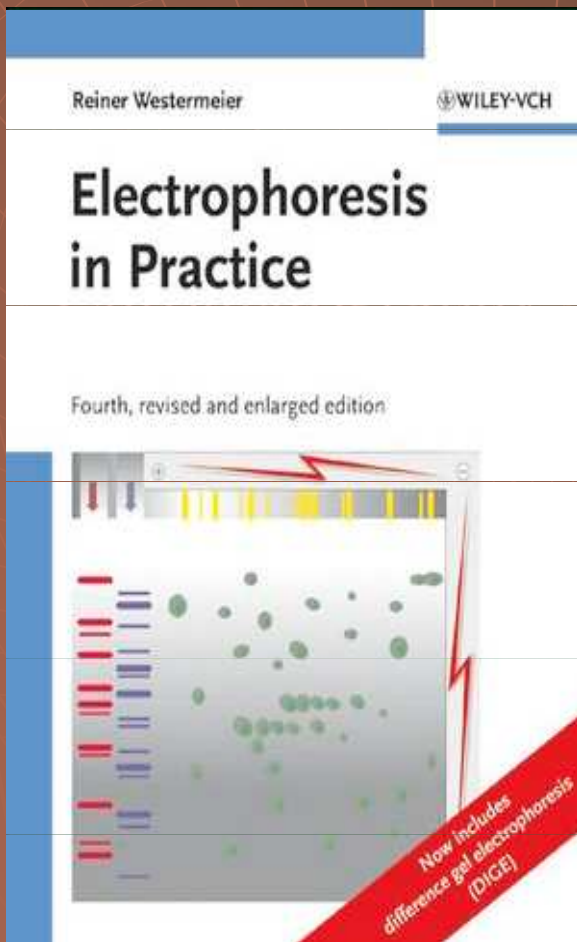

Historie elektromigračních metod

- ◆ 1906 Reuss

Elektroforéza – pohyb koloidní částic v elektrickém poli

- ◆ 1897 Kohlrausch

regulační funkce

- ◆ 1930 Arne Tiselius

Volná a zónová elektroforéza (1948 Nobelova cena)

Historie elektromigračních metod

- ◆ 1962 Vesterberg, (Svensson) Rilbe
izoelektrická fokusace
- ◆ 1967 Hjerten
kapilární elektroforéza v rotující 1 - 3 mm
křemenné kapiláře
- ◆ 1970 Laemmli
SDS PAGE

Historie elektromigračních metod

- ◆ 1975 O'Farrell
2D-elektroforéza
- ◆ 1976 Everaerts, Mikkers
isotachoforéza
- ◆ 2003 Karger
Multikapilární CE – lidský genom

Frederic Reuss

(1807)

Katoforéza

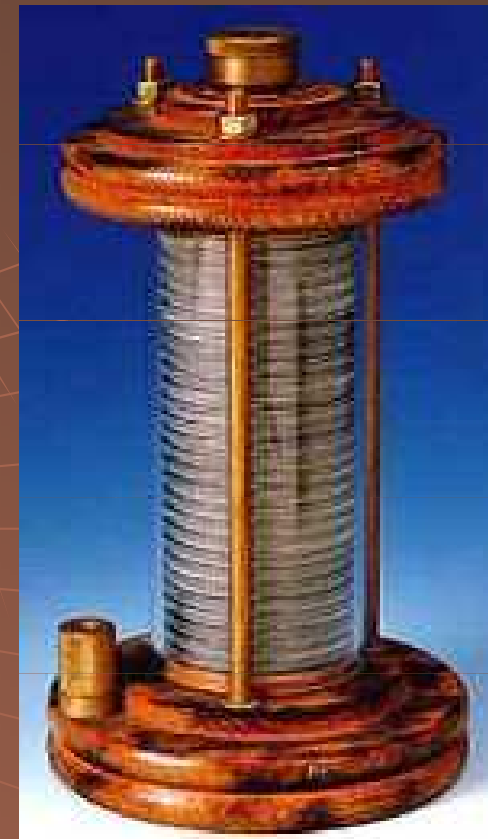
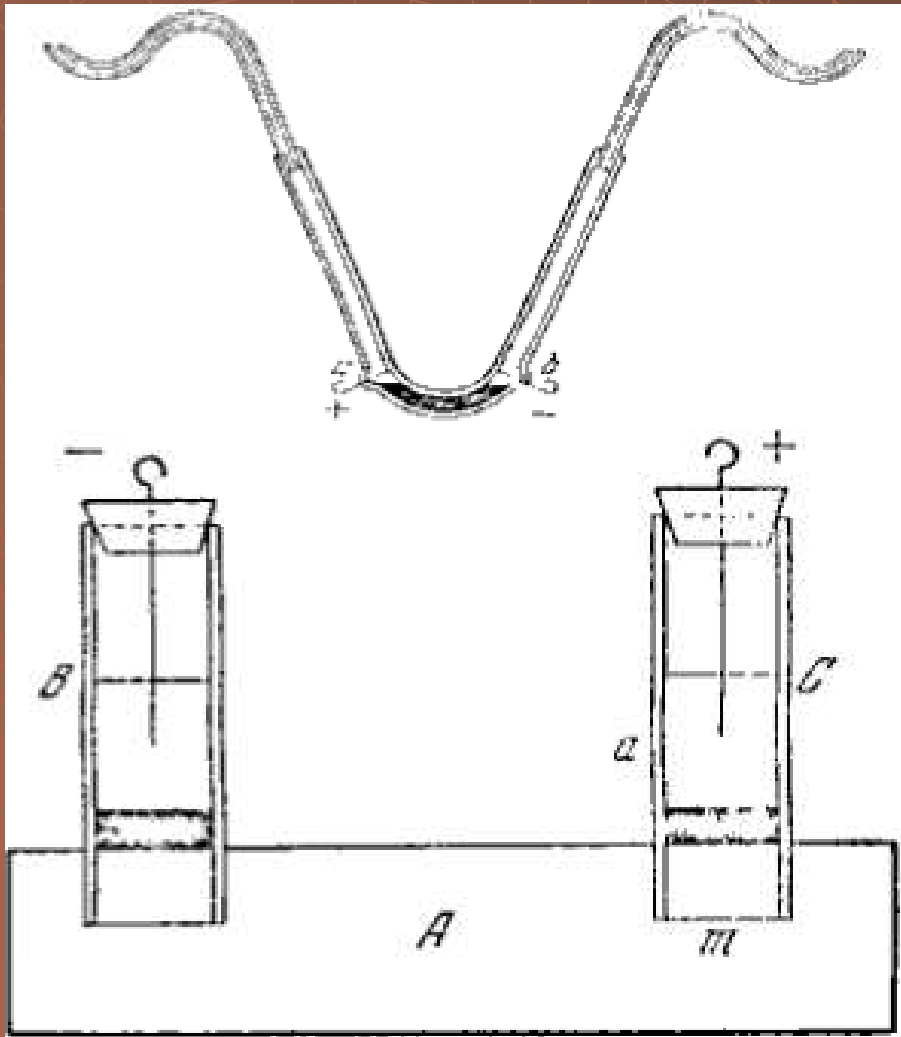

Friedrich Kohlrausch

(1874)

Regulační funkce

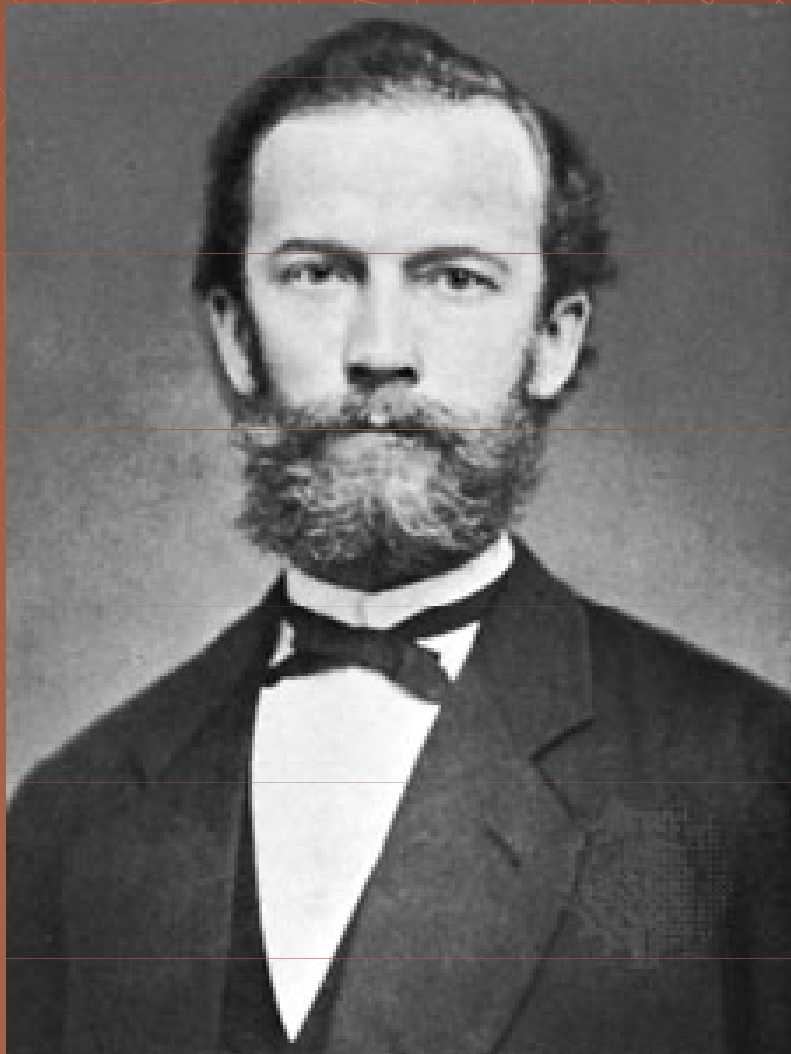

$$\sum_i \sum_z \frac{|z| c_i}{\mu_i} = K_x$$

Podstata

*„Pohyb elektricky nabitých
částic
v elektrickém poli“*



Teoretické aspekty elektromigračních metod

Mobilita

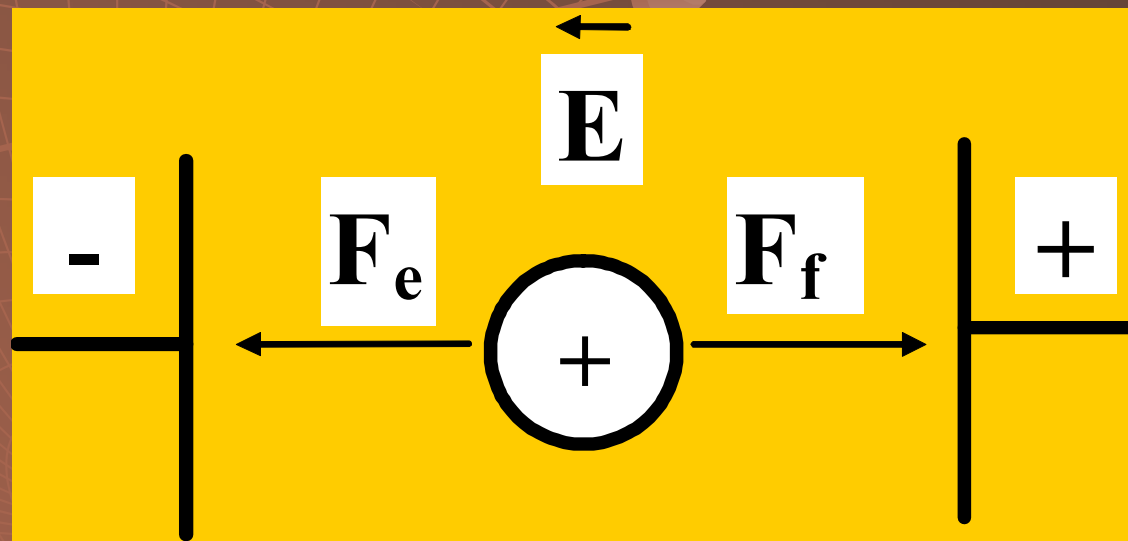

Elektrická síla F_e

$$F_e = E \times Q$$

E = intenzita elektrického pole [V/m]

Q = náboj částice = $z_i \times e$ []

Frikční síla F_f

$$F_f = v \times f$$

v = rychlost částice

f (frikční koeficient) = $6\pi \cdot \eta \cdot r$

Ustálený stav

$$E \times Q = v \times f$$



$$v = \frac{E \times Q}{f}$$

mobilita \implies

$$\mu = \frac{v}{E} = \frac{Q}{f}$$

$[\text{m}^{-2} \text{V}^{-1} \text{s}^{-1}]$

Iontová mobilita

(limitní zředění, teplota 298 K)

<i>KATIONTY</i>	$ \mu_0 .10^9$	<i>ANIONTY</i>	$ \mu_0 .10^9$
H ₃ O ⁺	362.5	OH ⁻	205.5
Li ⁺	40.1	F ⁻	57.4
Na ⁺	51.9	Cl ⁻	79.1
K ⁺	76.2	NO ₃ ⁻	74.1
Tris ⁺	29.5	SO ₄ ⁻	82.9
β-alanin	36.7	k.mléčná	36.5
ethanolamin	44.3	k.octová	42.4
imidazol	52.0	MES	28.0

Efektivní mobilita

$A_0, A_1, A_2, \dots, A_k$

$\mu_0, \mu_1, \mu_2, \dots, \mu_k$

$$\bar{\mu}_A = \frac{1}{c_A} \times \sum_{i=0}^k c_i \mu_i = \sum_{i=0}^k x_i \mu_i$$

c_A = celková analytická koncentrace látky A

x_i = molární zlomek iontu i

Závislost efektivní mobility na pH

- ❖ pro slabou monovalentní kyselinu

$$\bar{\mu}_A = \frac{[H^+]}{K_{HA} + [H^+]} \times \mu_A$$

- ❖ pro slabou monovalentní zásadu

$$\bar{\mu}_B = \frac{[H^+]}{K_{BH} + [H^+]} \times \mu_{BH}$$

Závislost efektivní mobility na pH pro slabou monovalentní zásadu

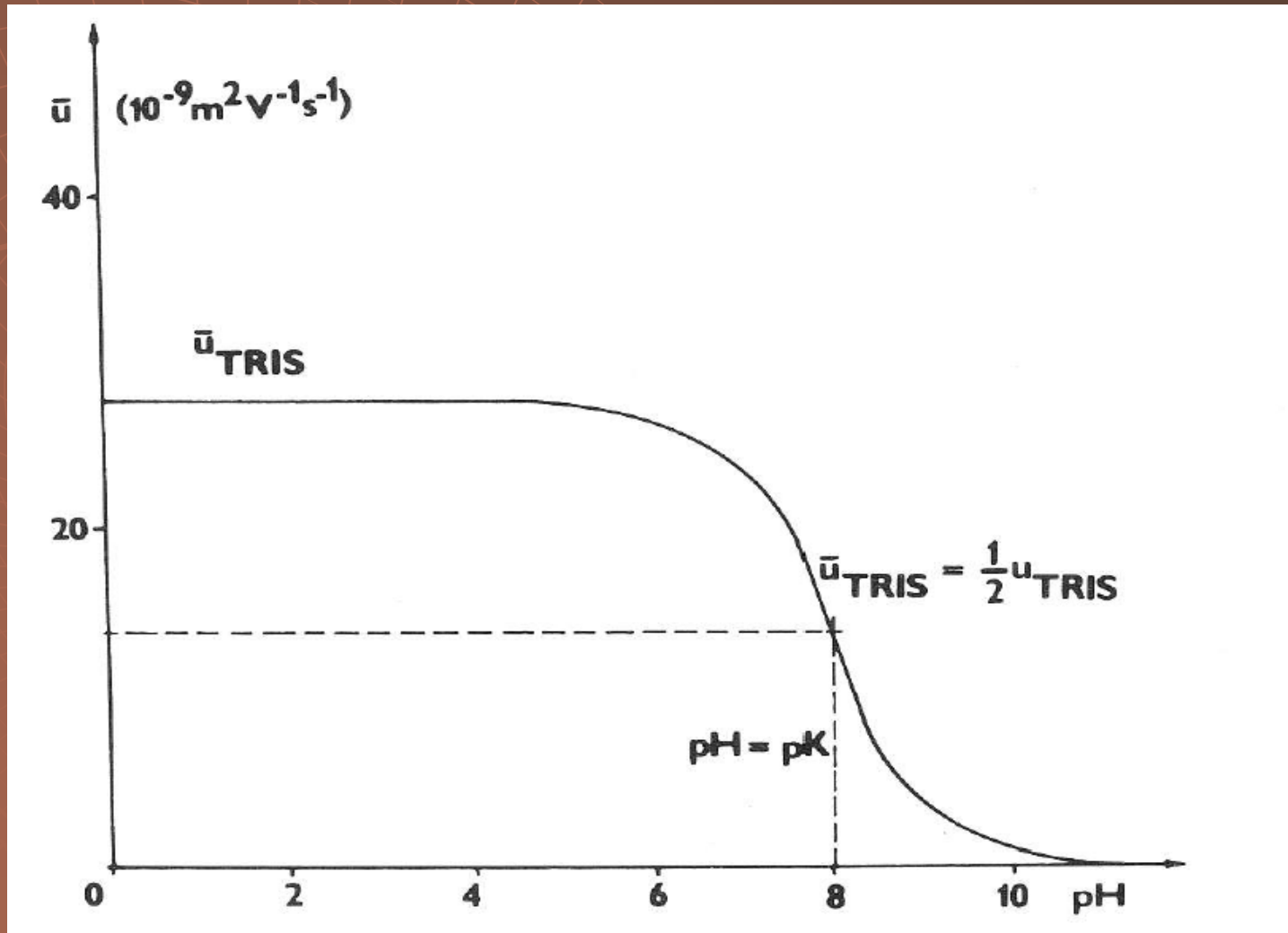

Závislost efektivní mobility na pH

pro slabou monovalentní kyselinu

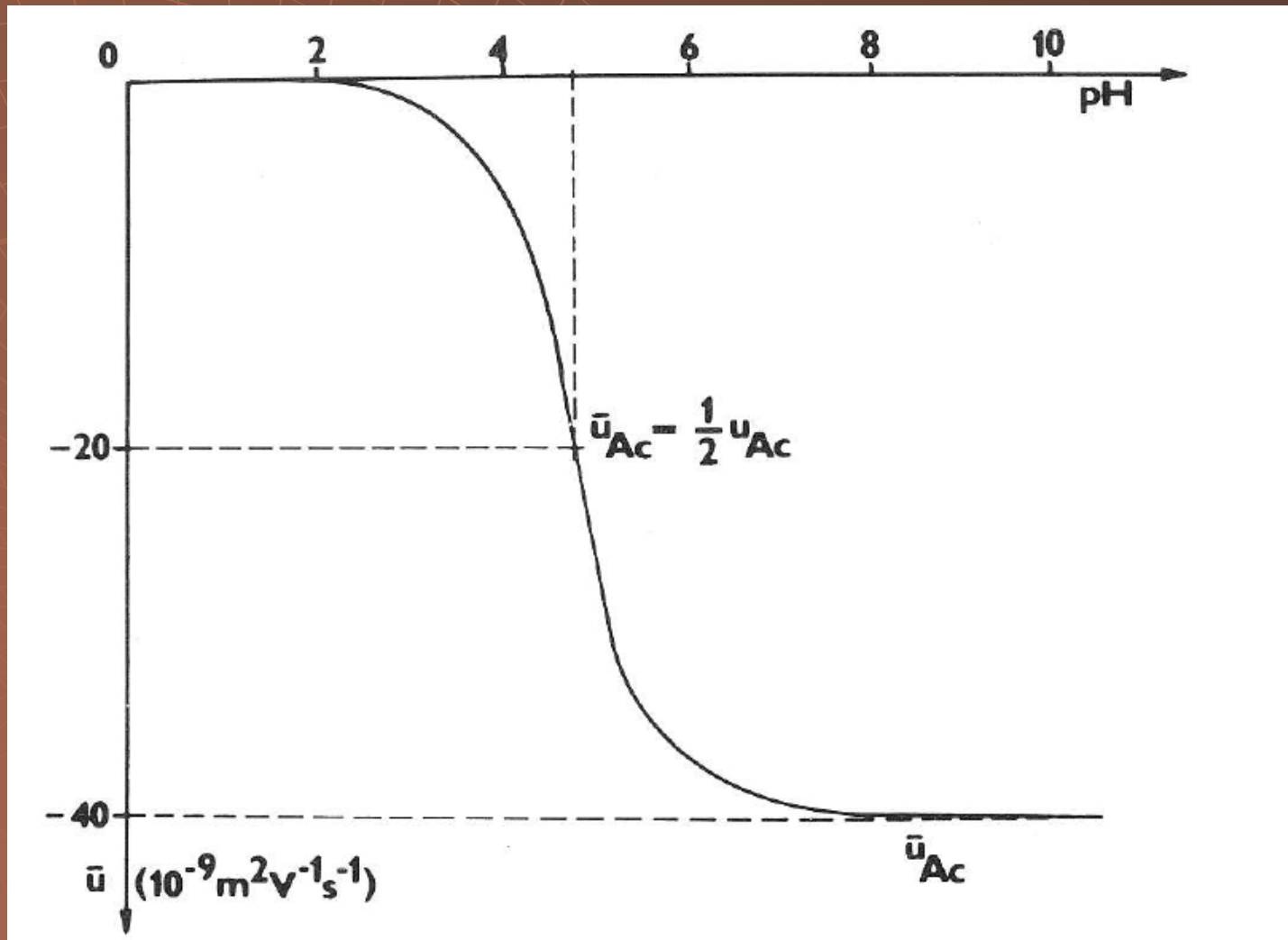

Závislost efektivní mobility na pH pro bílkovinu

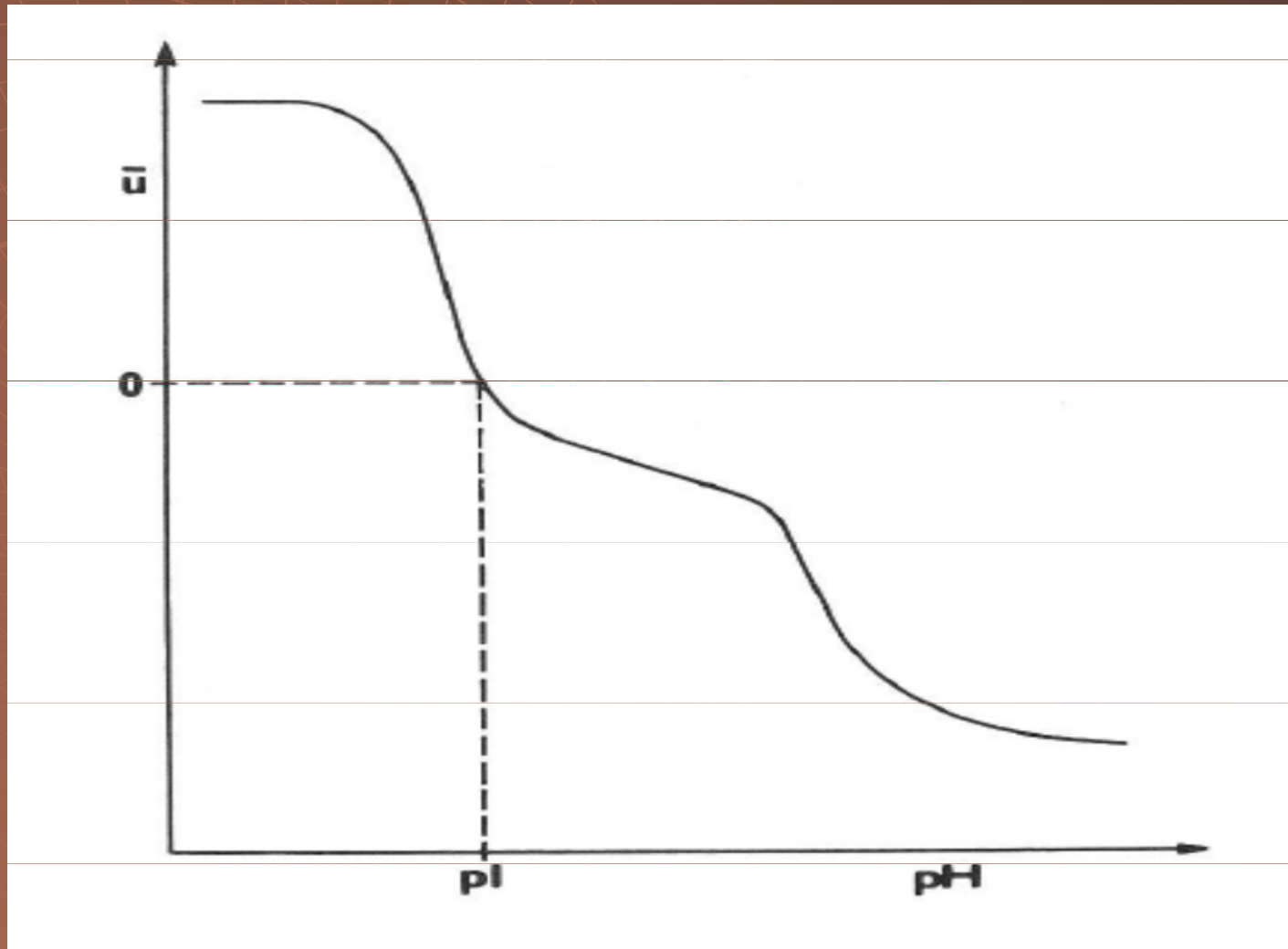

Vliv velikosti molekuly na mobilitu

$$\mu = \frac{Q}{f}$$

$$\mu = \frac{Q}{6\pi\eta r}$$

$$\frac{1}{r} \approx M_r^{\frac{1}{3}}$$

η - viskozita prostředí

r – poloměr částice

Vliv iontové síly na mobilitu

$$|\mu| = |\mu_o| - (0.23|\mu_o z z_c| + 31.3 \times 10^{-9} |z|) \times \frac{\sqrt{I}}{1 + \sqrt{I}}$$

z = náboj iontu

z_c = náboj protiiontu

I – iontová síla

Vliv teploty na mobilitu

$$\mu_T = \mu_{T_0} \times [1 + 0.02 \times (T - T_0)]$$

T_0 = standardní teplota

T = pracovní teplota

Sekundární jevy

- ◆ Jouleovo teplo
- ◆ Elektroosmóza
- ◆ Difuze

Jouleovo teplo

$$P = \frac{E \times i}{S} = \frac{i^2}{\kappa \times S^2}$$

P = výkon [W.m⁻³]

S = průřez [m²]

κ = vodivost [Ω^{-1} .m⁻¹]

i = elektrický proud [A]

Elektroosmotický tok

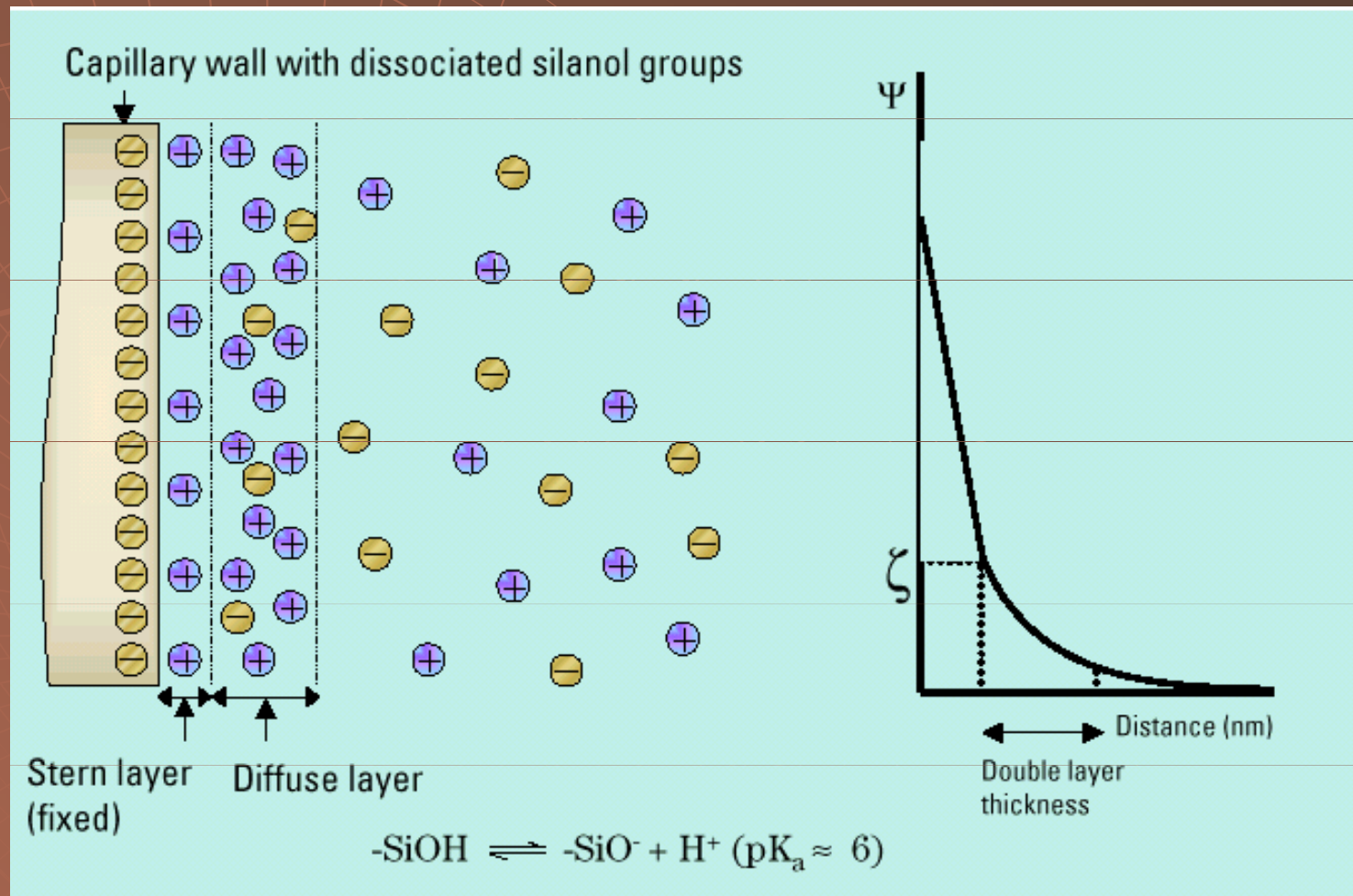

Elektroosmotický tok

$$\xi = \frac{4\pi\eta\mu_{eo}}{\varepsilon}$$

ξ = potenciál Helmholtzovy dvojvrstvy

η = viskozita

ε = dielektrická konstanta

μ_{eo} = elektroosmotická mobilita

$$v_{eo} = \frac{\varepsilon}{4\pi\eta} \times E\xi$$

Původ elektroosmotického toku

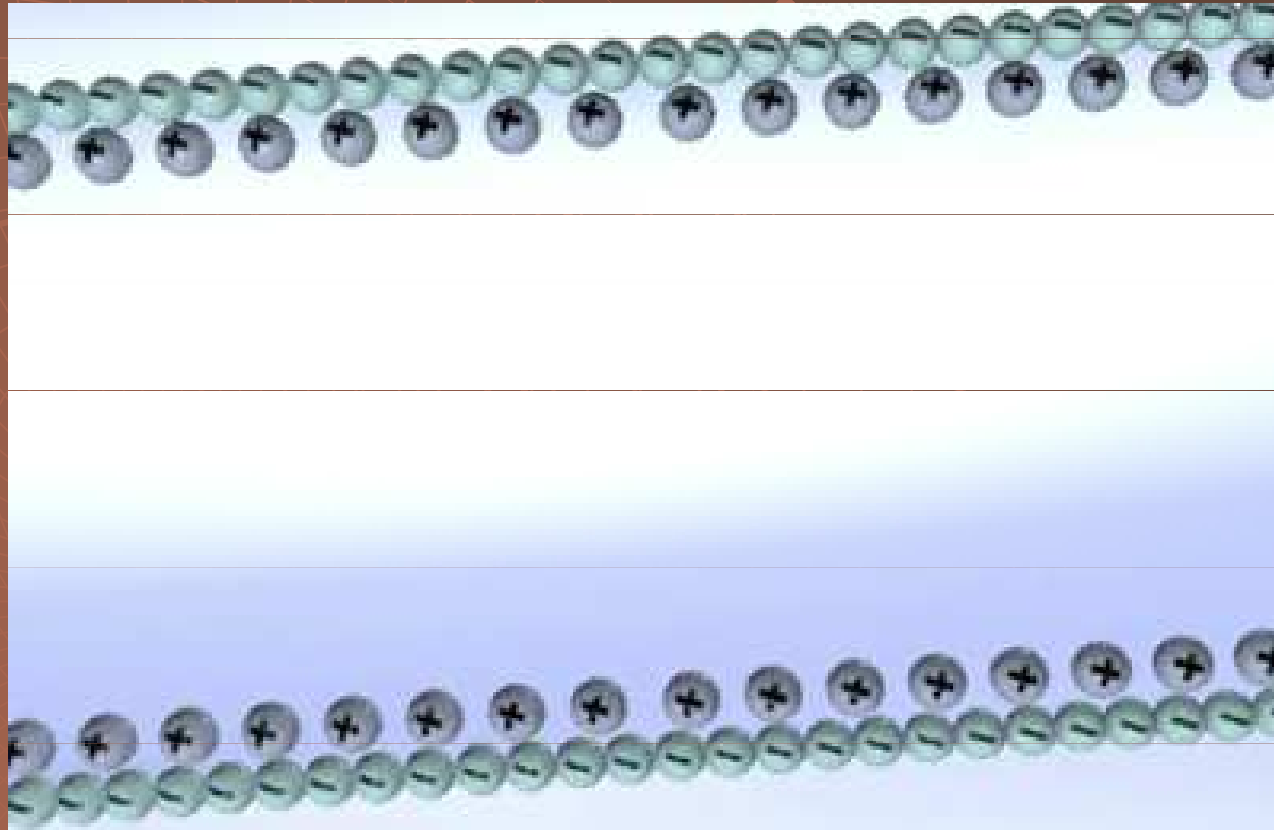

Elektroosmotický tok

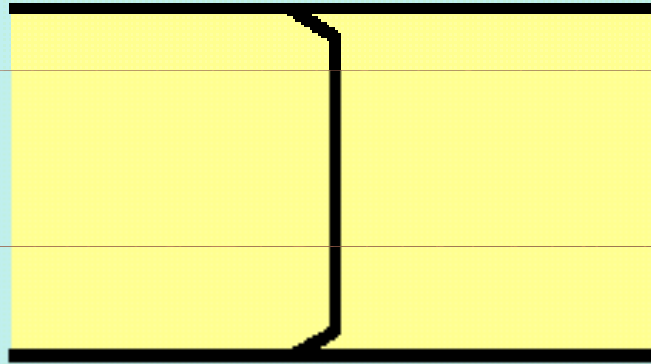

Laminární tok

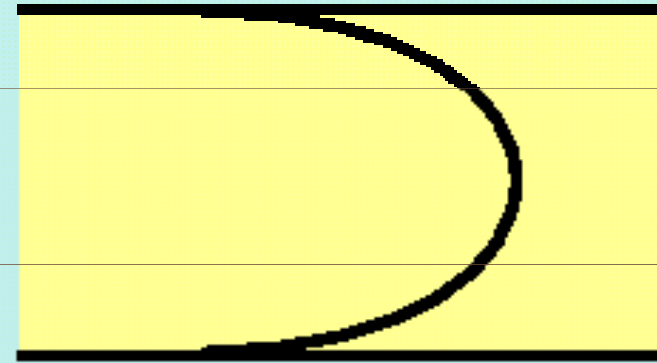

Elektroosmotický tok v různých kapilárách

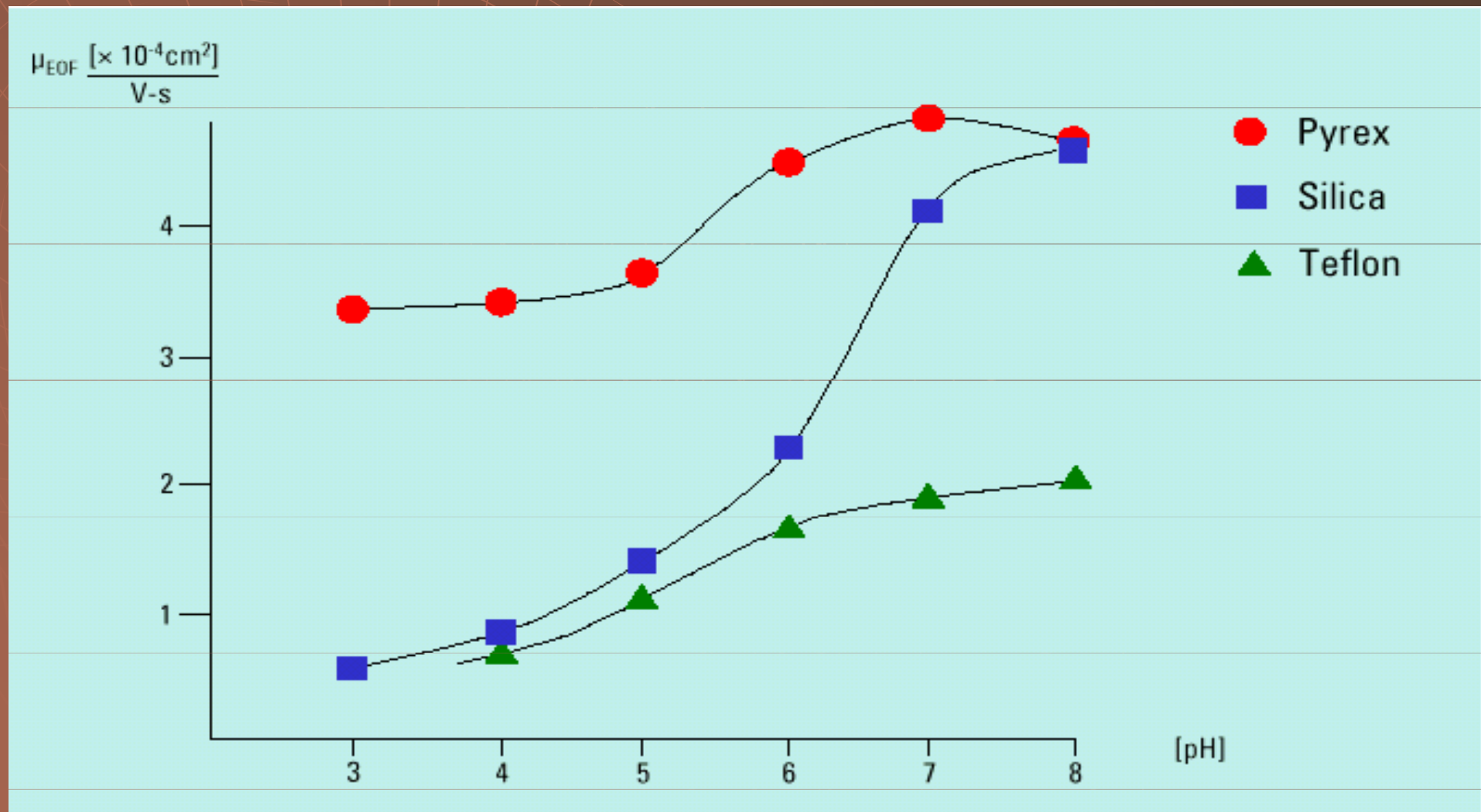

Difuze

$$c = c_0 e^{-\left(\frac{x^2}{\sigma^2}\right)}$$

$$\sigma = \sqrt{2Dt}$$

$\sigma^2 = \text{rozptyl}$

$D = \text{difuzní koeficient}$

Difuze

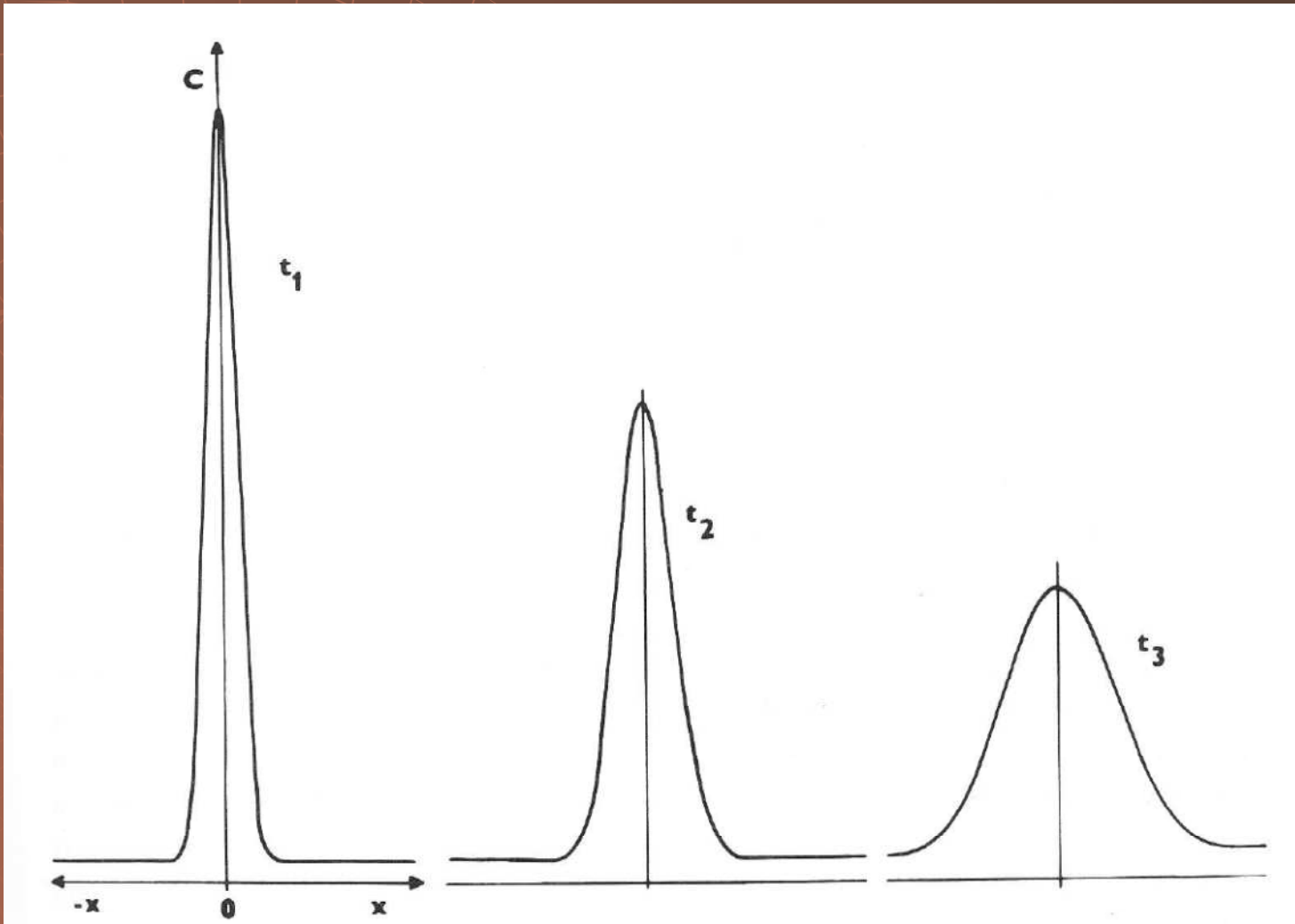

Elektroforéza

*„Dělení nabitých částic na
základě rozdílných
elektroforetických mobilit“*

Elektroforéza

- ◆ Volná
 - ◆ Zónová
- 
- The background of the slide features a faint, light-brown diagram of a gel electrophoresis apparatus. It shows a large, semi-circular grid of wells, with a central electrode and a smaller electrode at the top right. The diagram is overlaid on a dark brown background.

Volná elektroforéza

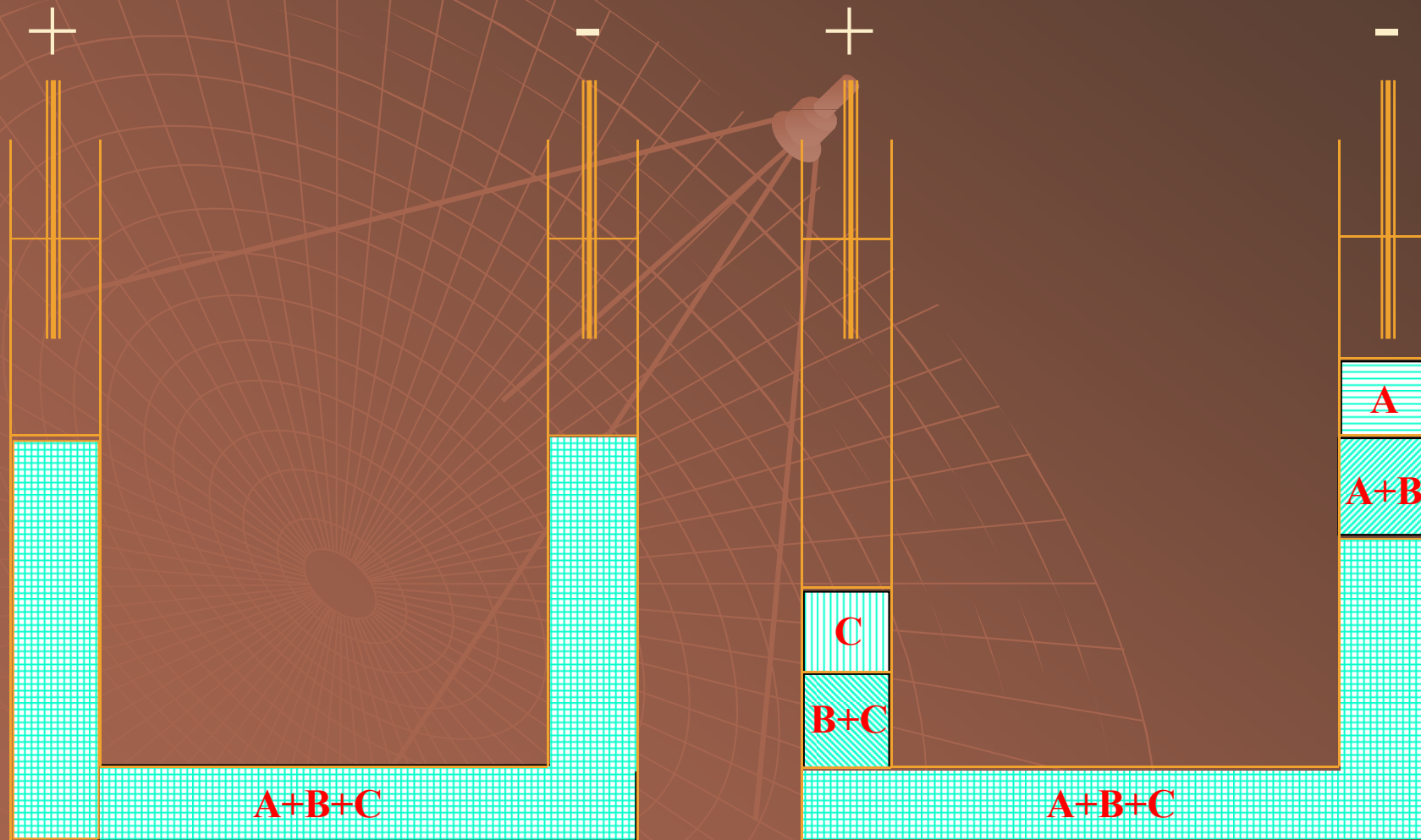

$$\mu_A > \mu_B > \mu_C$$

Volná elektroforéza

Arne Tiselius (1902 – 1971)

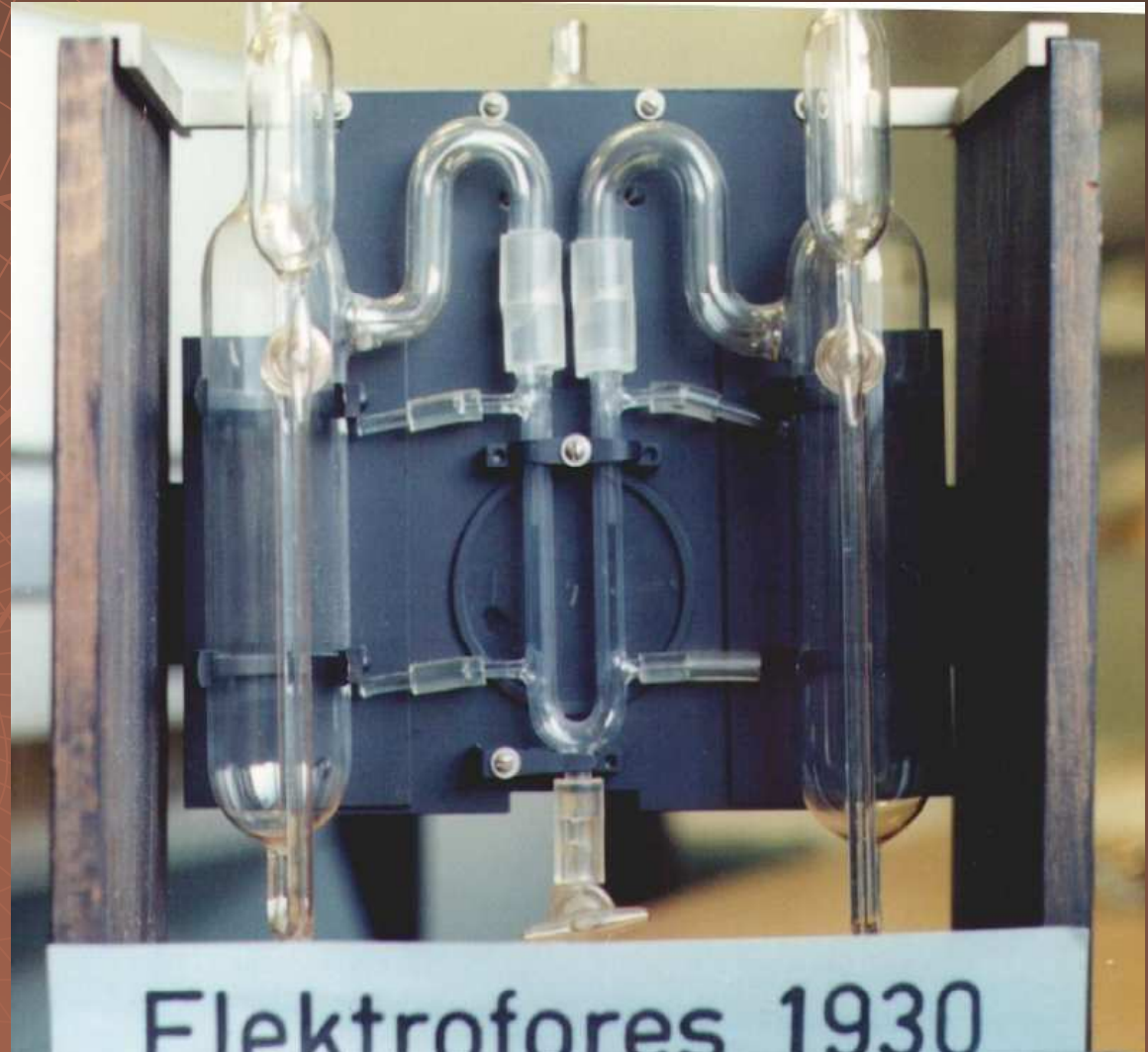
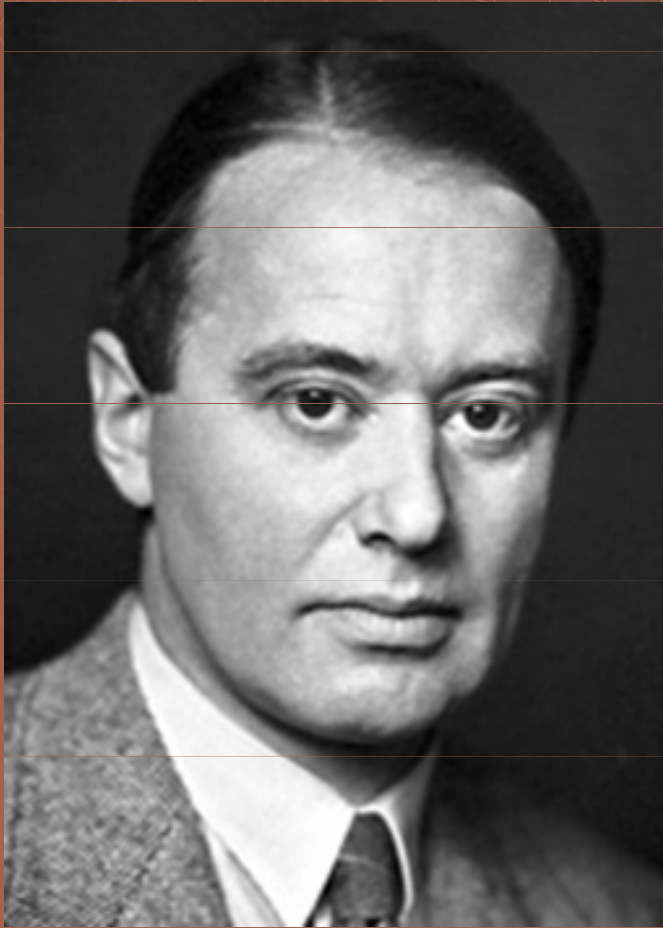

Volná elektroforéza

Arne Tiselius

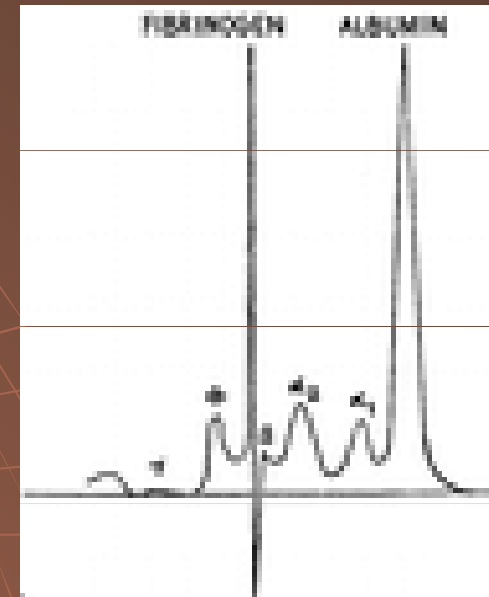
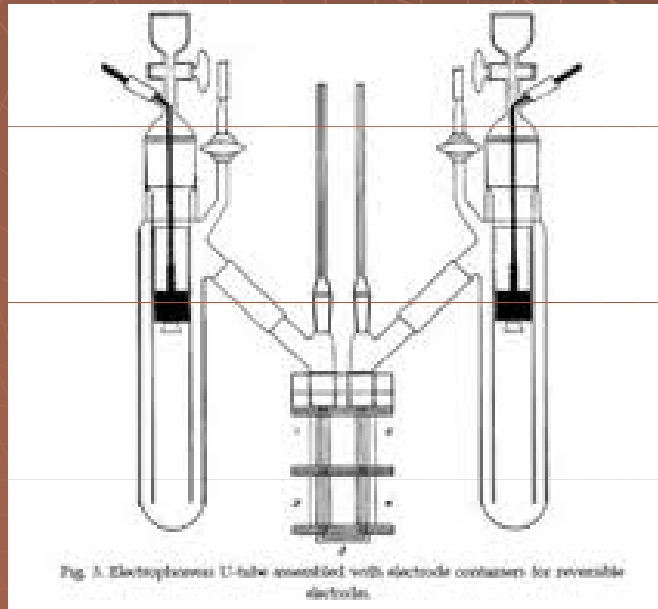

Volná elektroforéza

Arne Tiselius (1902 – 1971)

Nobelova cena 1948



Zónová elektroforéza

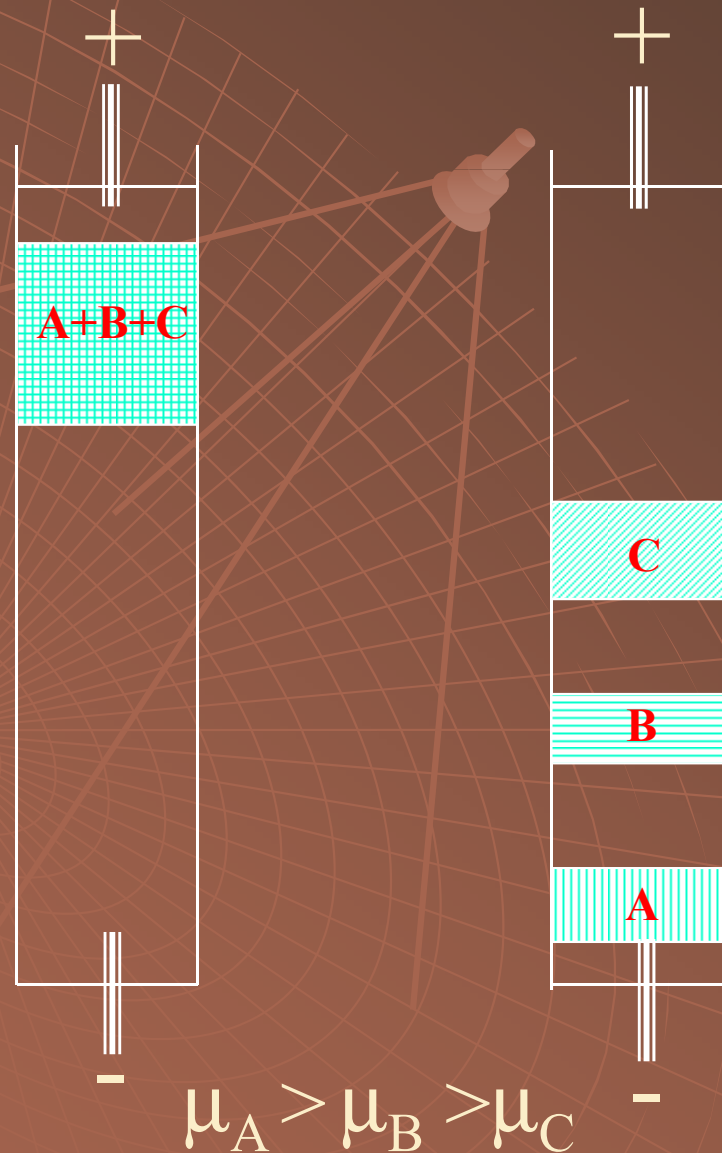

Skylab



Skylab

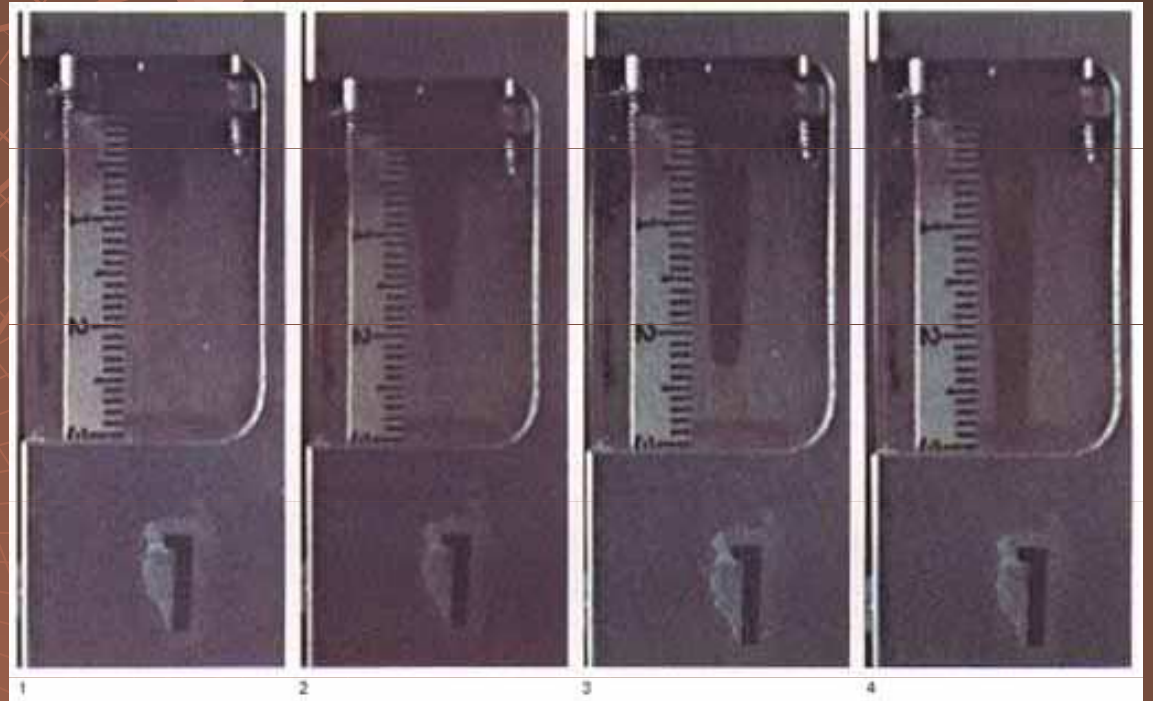
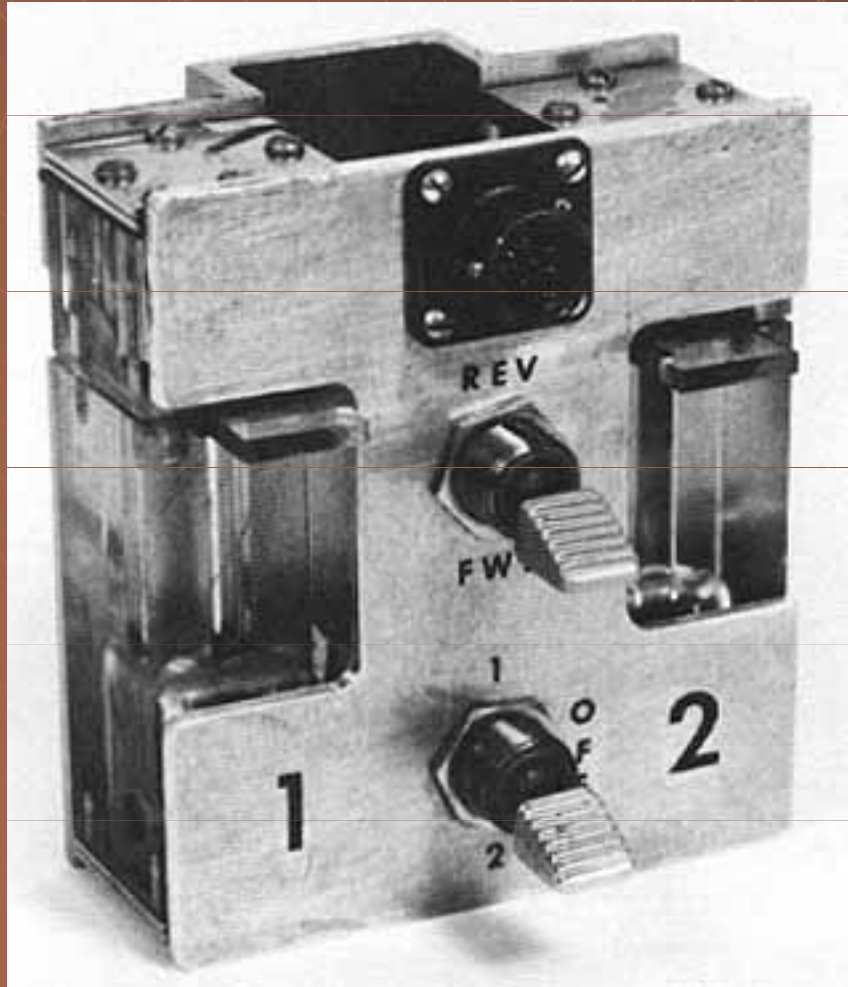

Stabilizace

- ◆ Rotací
- ◆ Gradienty hustoty
- ◆ Porézními medii
- ◆ Kapilárou

Stabilizace Rotací

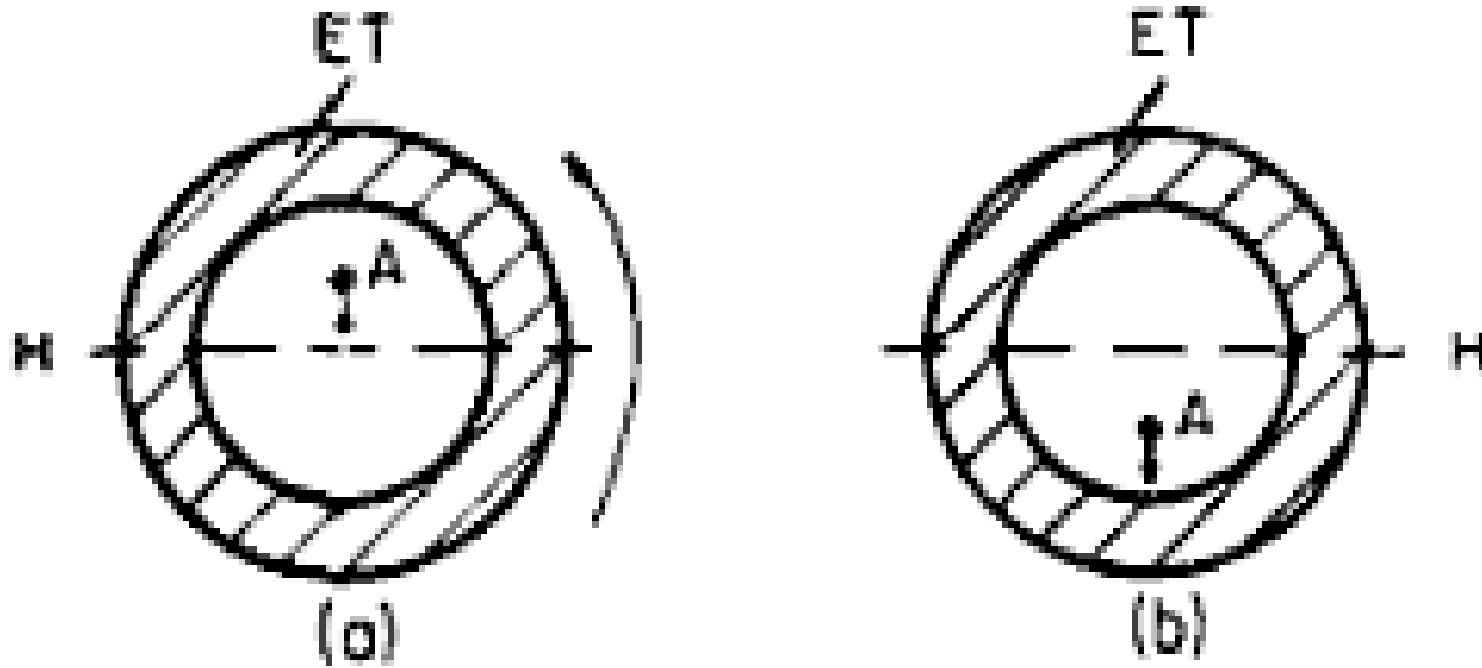

Stabilizace

Gradienty hustoty

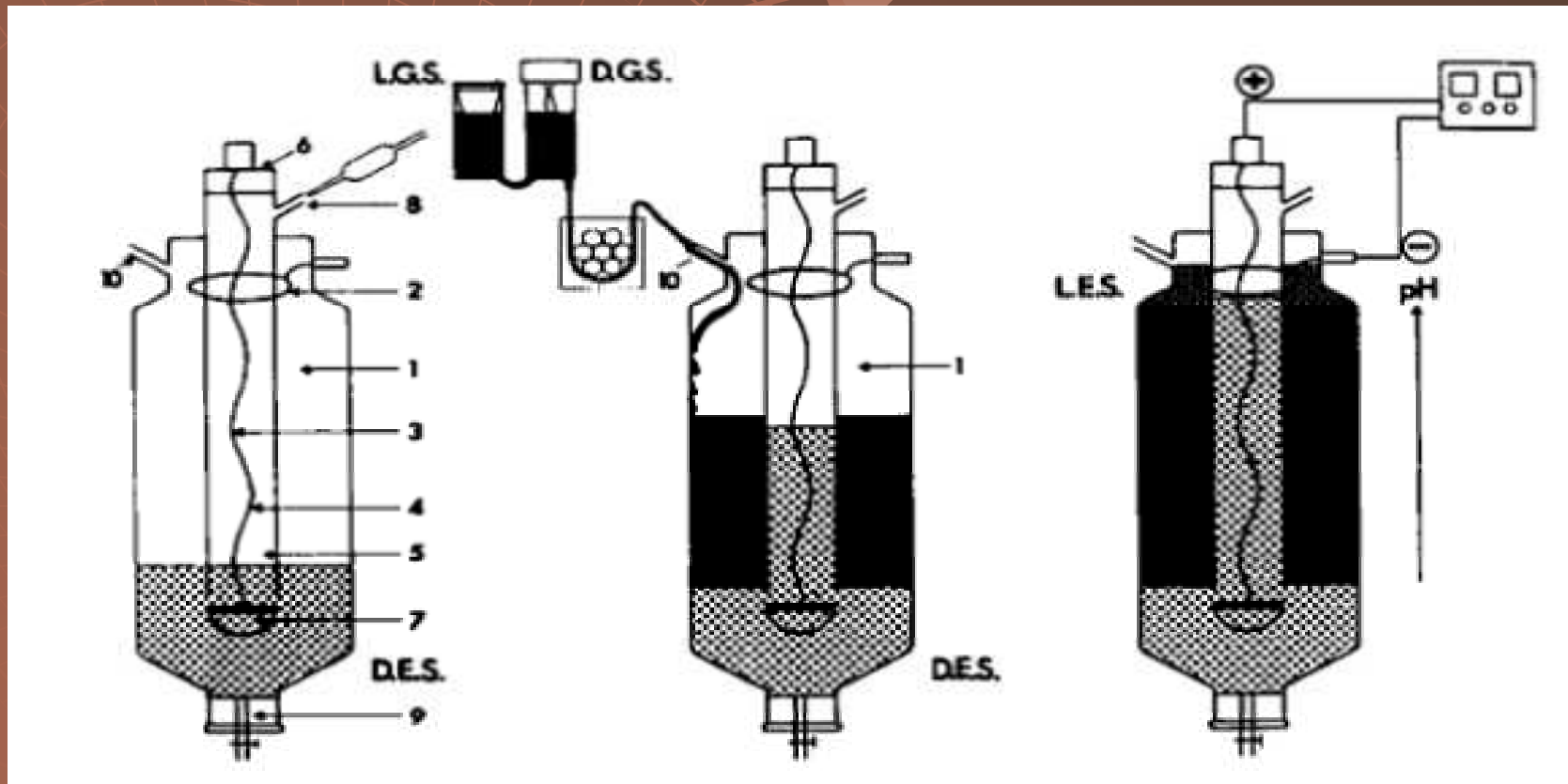

Stabilizace

Gradienty hustoty

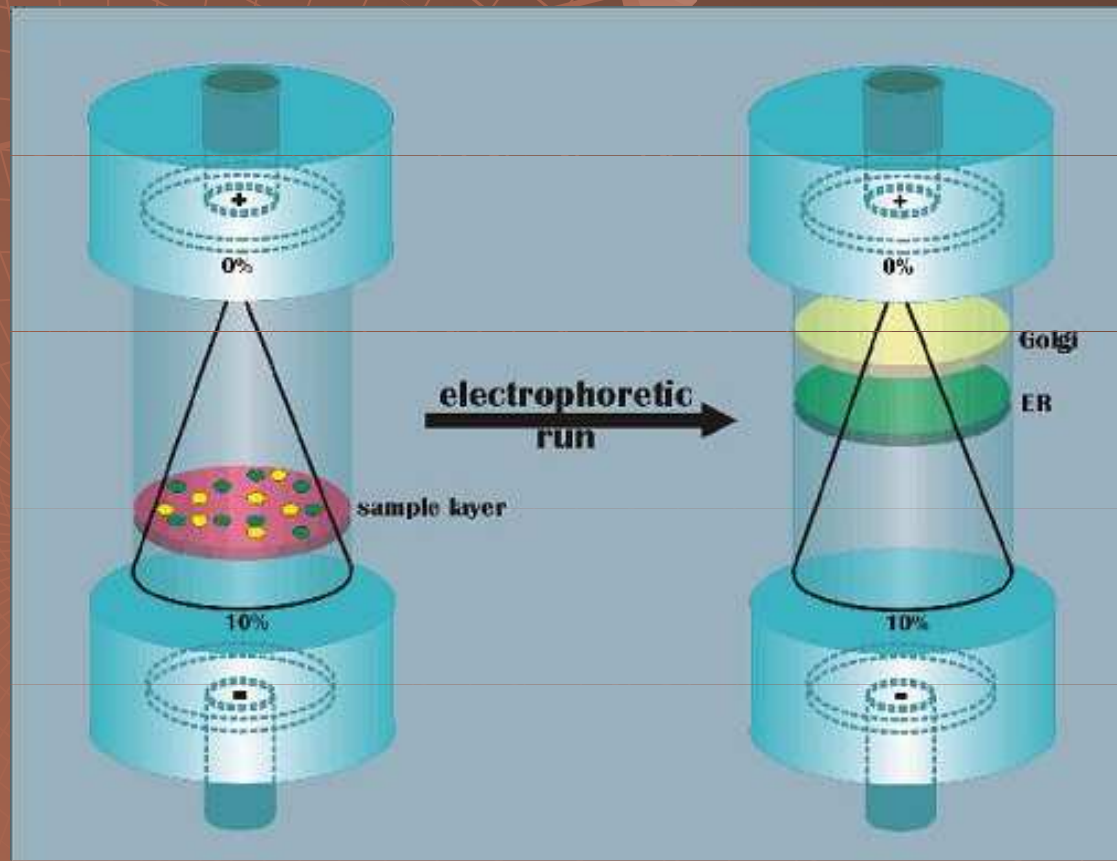

Požadavky na porézní media

- ◆ Homogenita
- ◆ Inertnost - nespecifické interakce
- nulový EOF
- ◆ Reprodukovatelná a snadná příprava
- ◆ Mechanická pevnost
- ◆ Transparentnost

Porézní media

- ◆ 1939 *Papír*
- ◆ 1950 *Agarový gel*
- ◆ 1955 *Škrobový gel*
- ◆ 1957 *Acetát celulosy*
- ◆ 1959 *Polyacrylamidový gel*
- ◆ 1979 *Agarosový gel*

Chromatografický papír

Složení – celuloza

- Nehomogenní
- Přítomnost ionogenních skupin
- Špatně se chladí – pálí se

Použití : téměř už se nepoužívá

Chromatografický papír

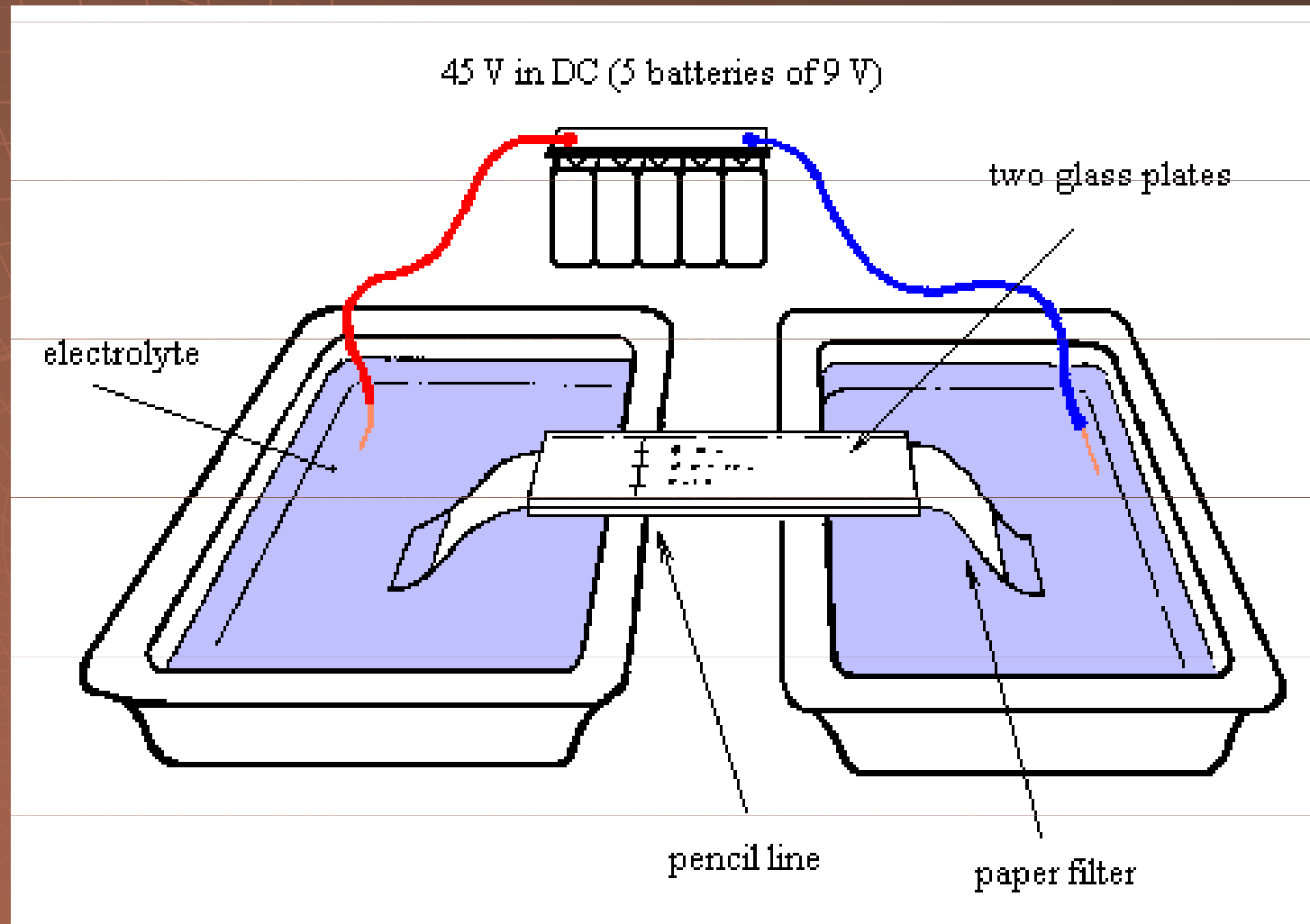

Chromatografický papír

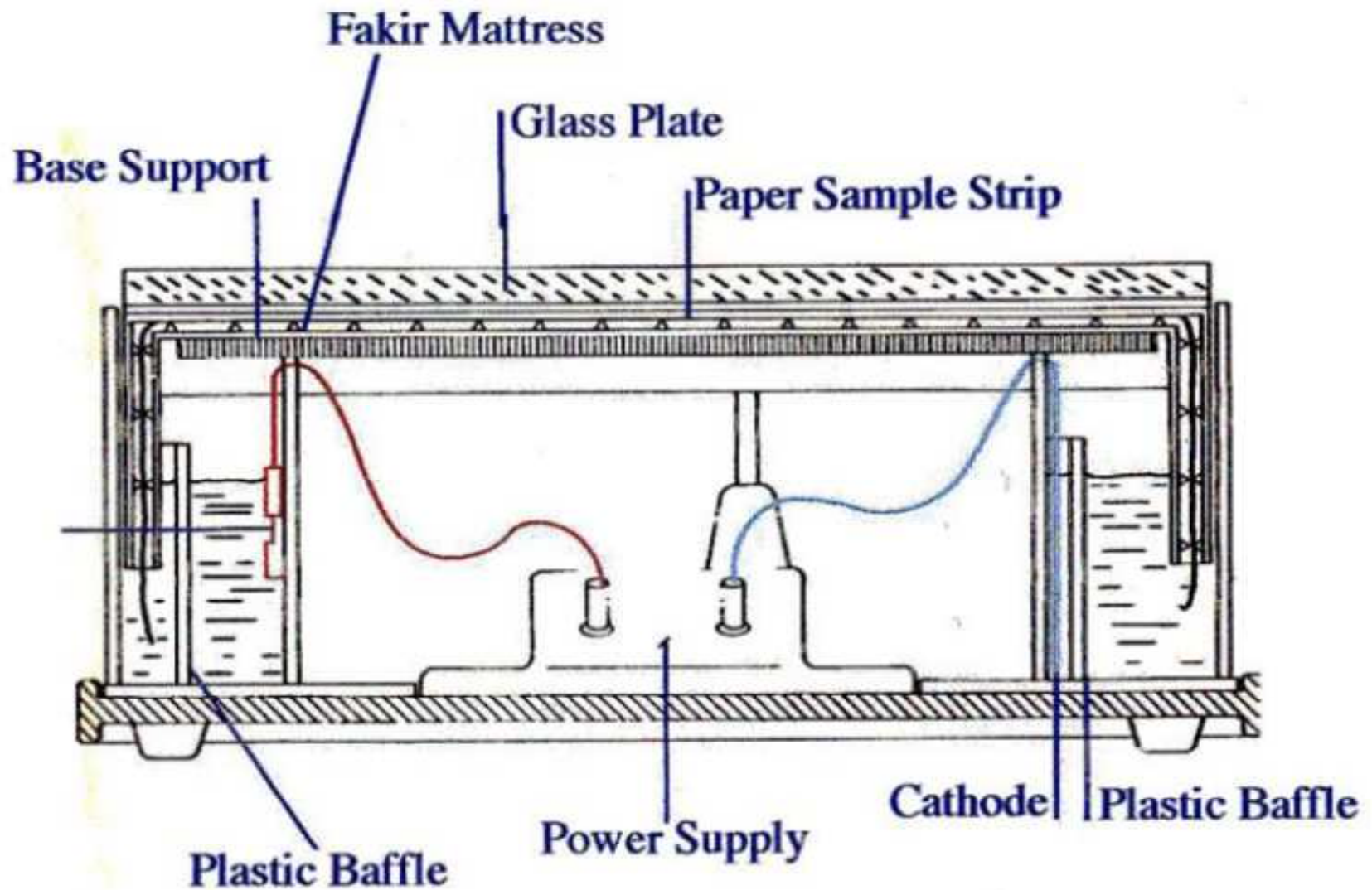

Acetát celulosy

Složení – acetát celulosy

- + Komerčně dostupný
- + Dobré mechanické vlastnosti

Použití : imunoelektroforetické
metody, klinické aplikace

Acetát celulosy

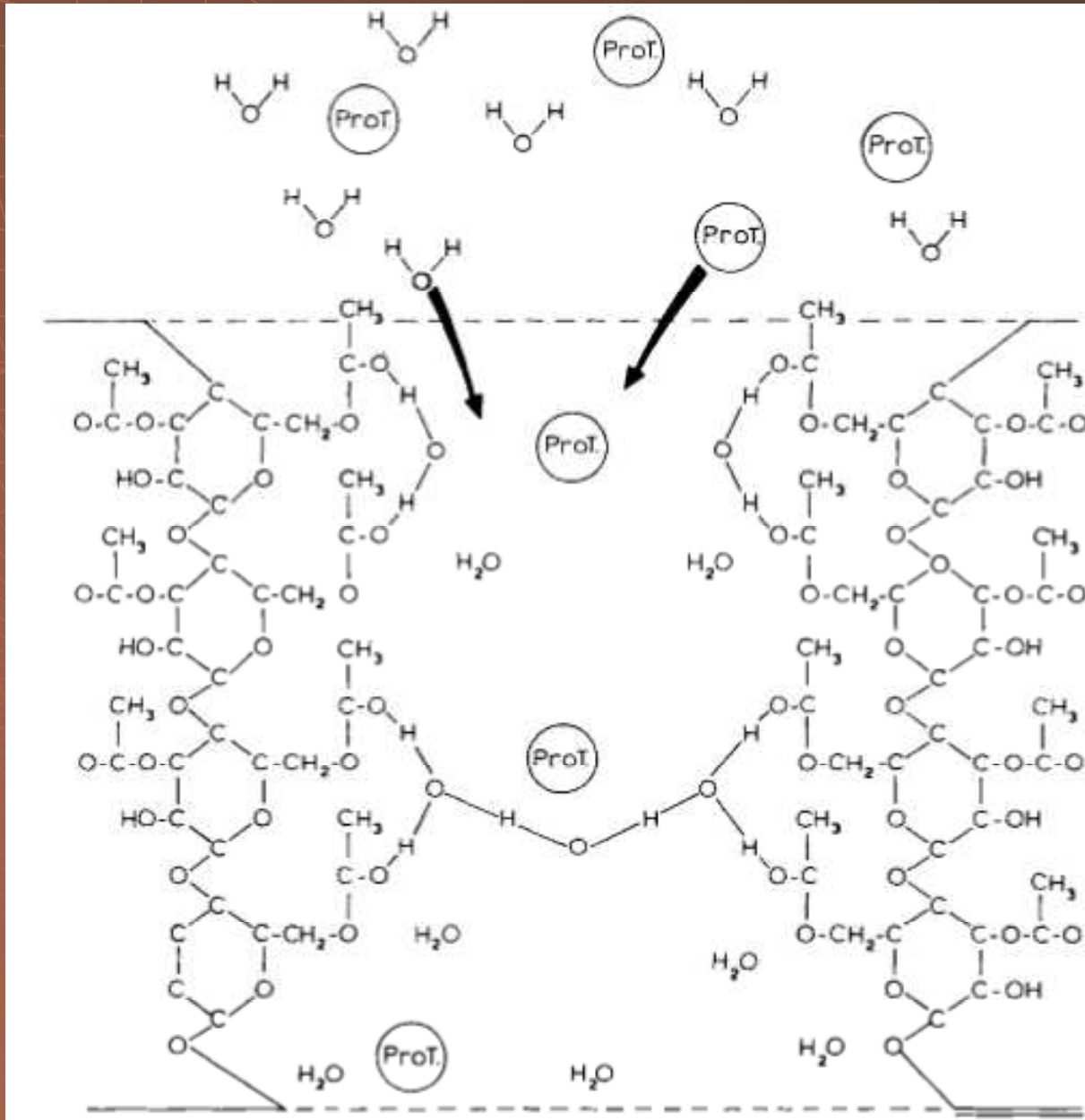

Acetát celulosy

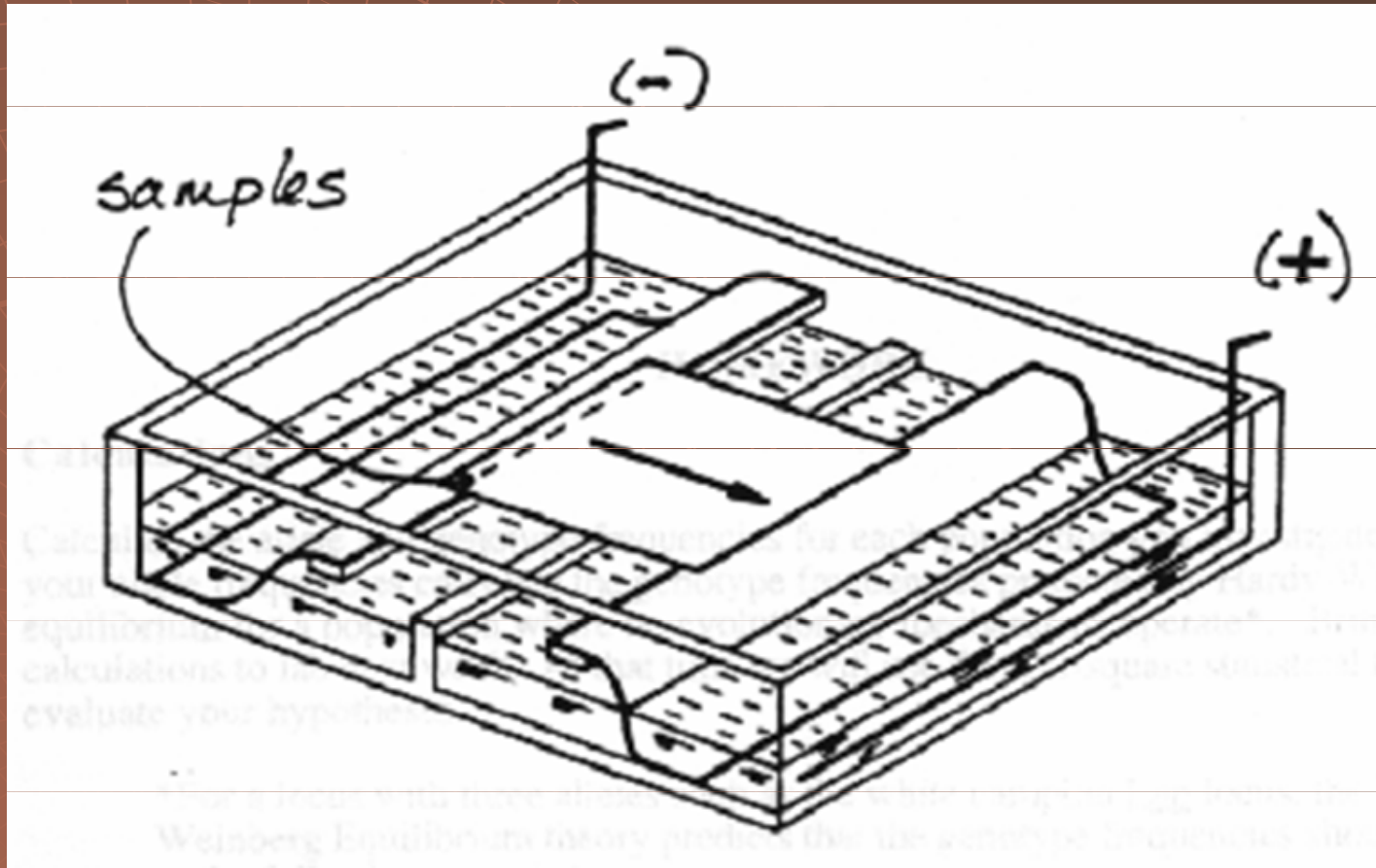

Acetát celulosy

analýza sérových bílkovin

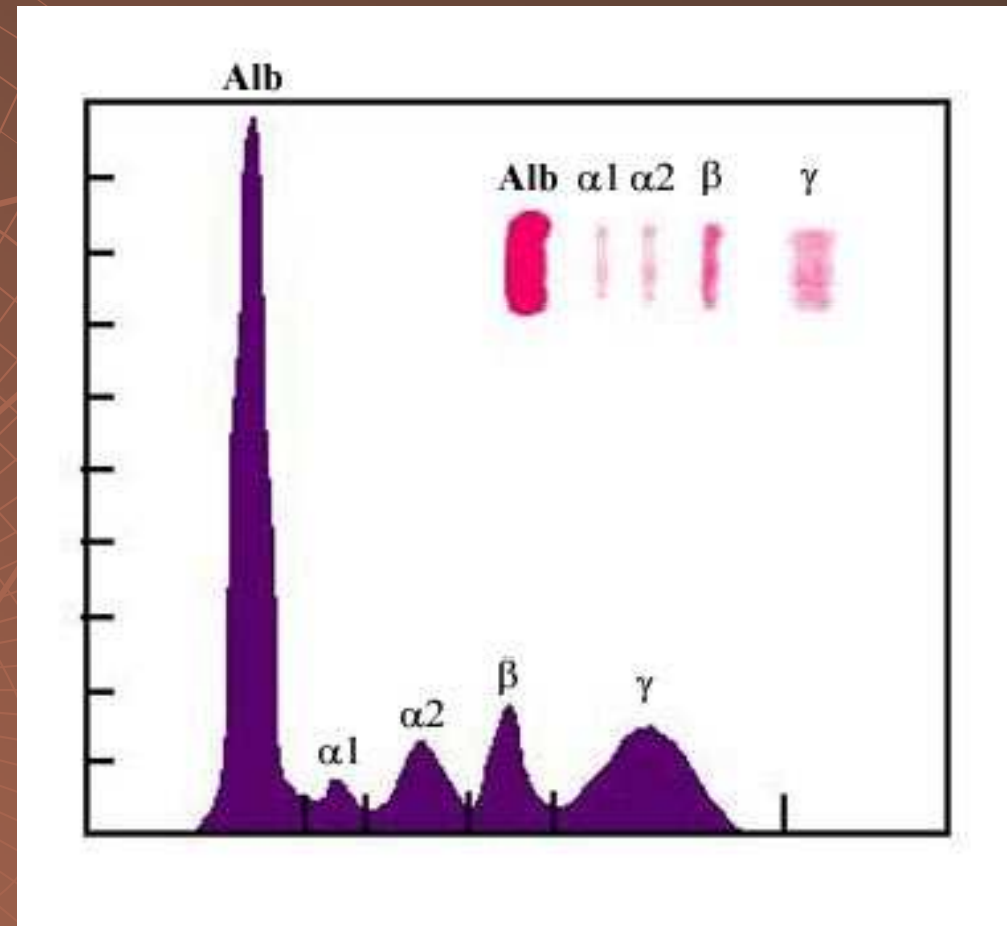
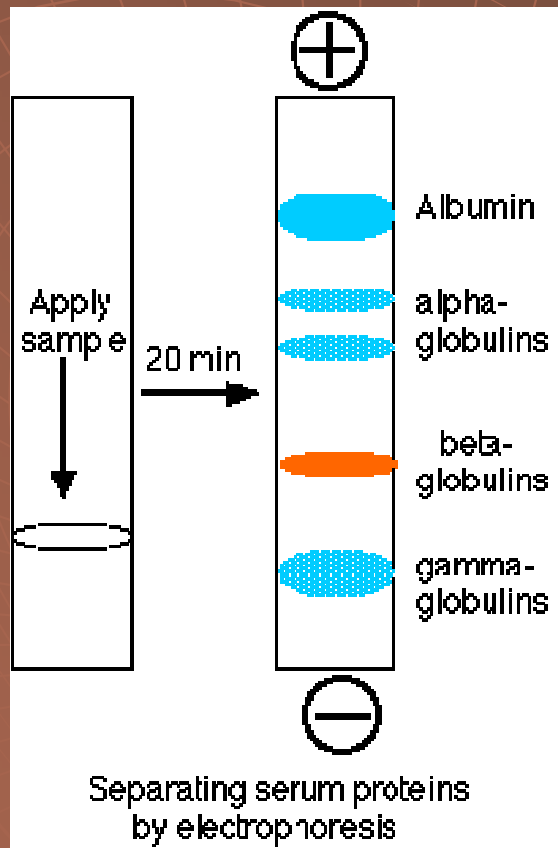

Acetát celulosy

hemoglobinu

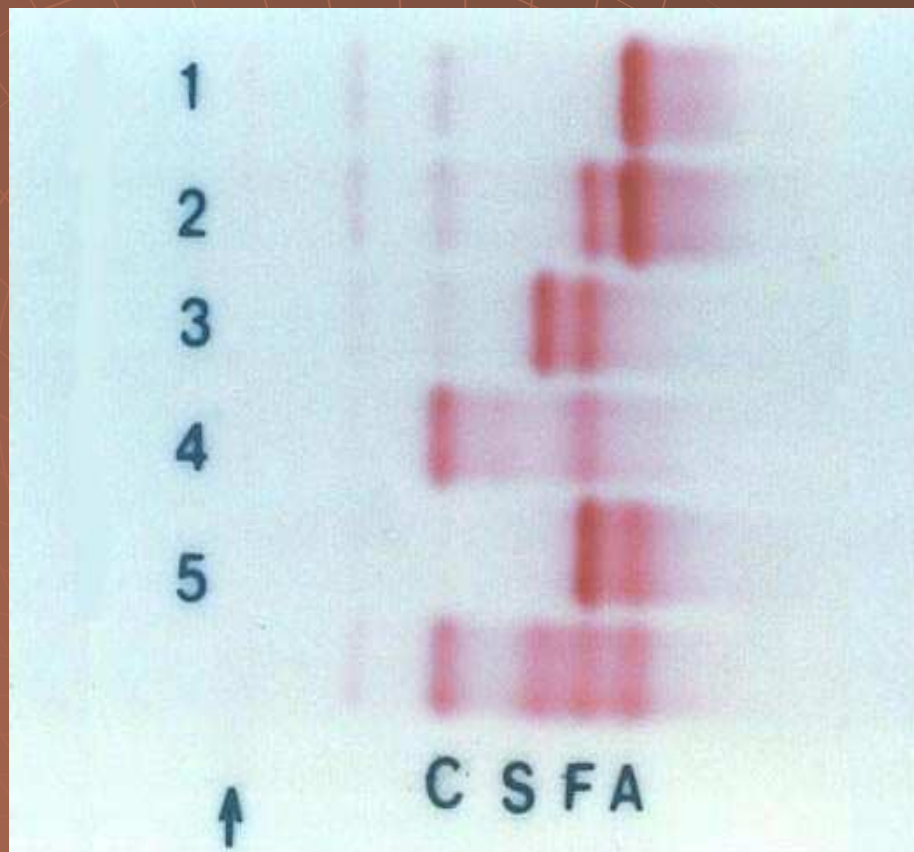

**HPFH –
dědičné přetrvávání
hemoglobinu F (“hereditary
persistence”)**

pH 8.4

1. Normální dospělý
2. HPFH (heterozygot)
3. Hb S--HPFH
4. Hb C--HPFH
5. Normální novorozenec

Hemoglobin S a C – mutace v primární struktuře, náhrada jedné z aminokyselin za druhou.

Agar a agarosa

Složení – kopolymer galaktosy a anhydrogalaktosy

- Přítomnost ionogenních skupin – silný EOF
- + Velké pory
- + Snadná příprava

Použití : imunoelektroforetické metody
elektroforéza NK

Agar a agarosa

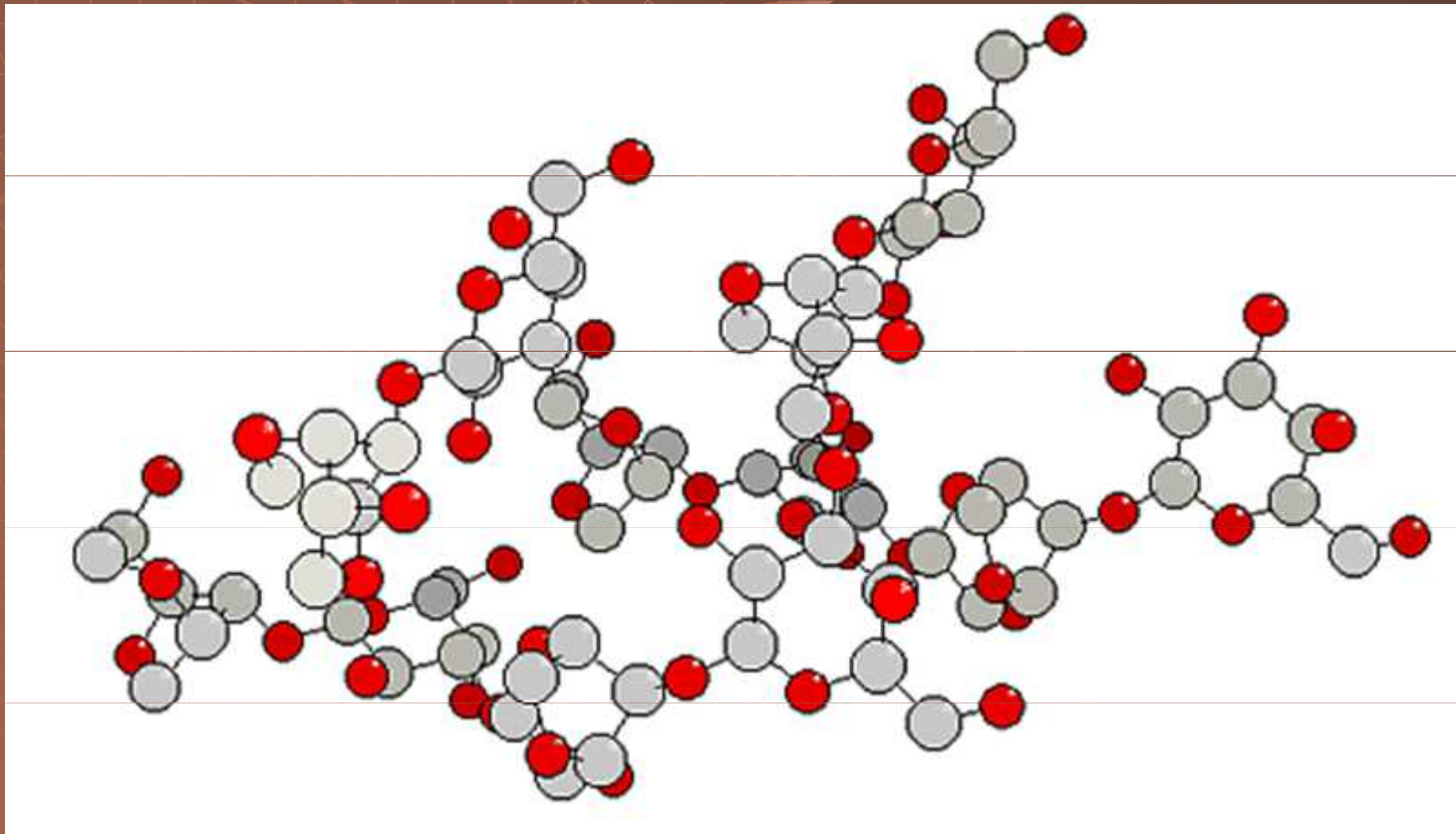

Agar a agarosa

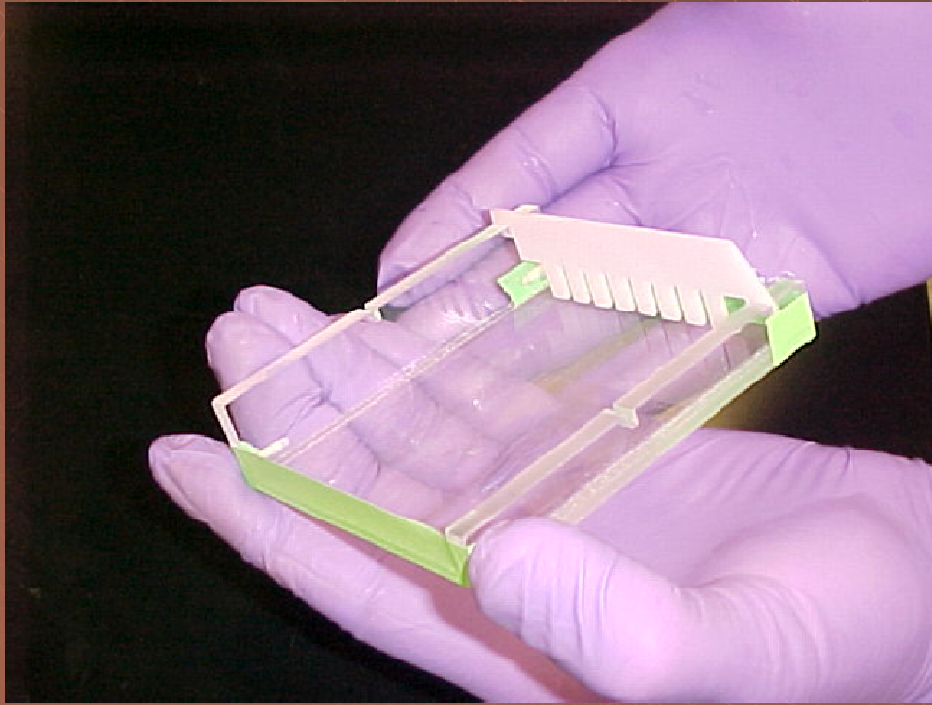

Agar a agarosa

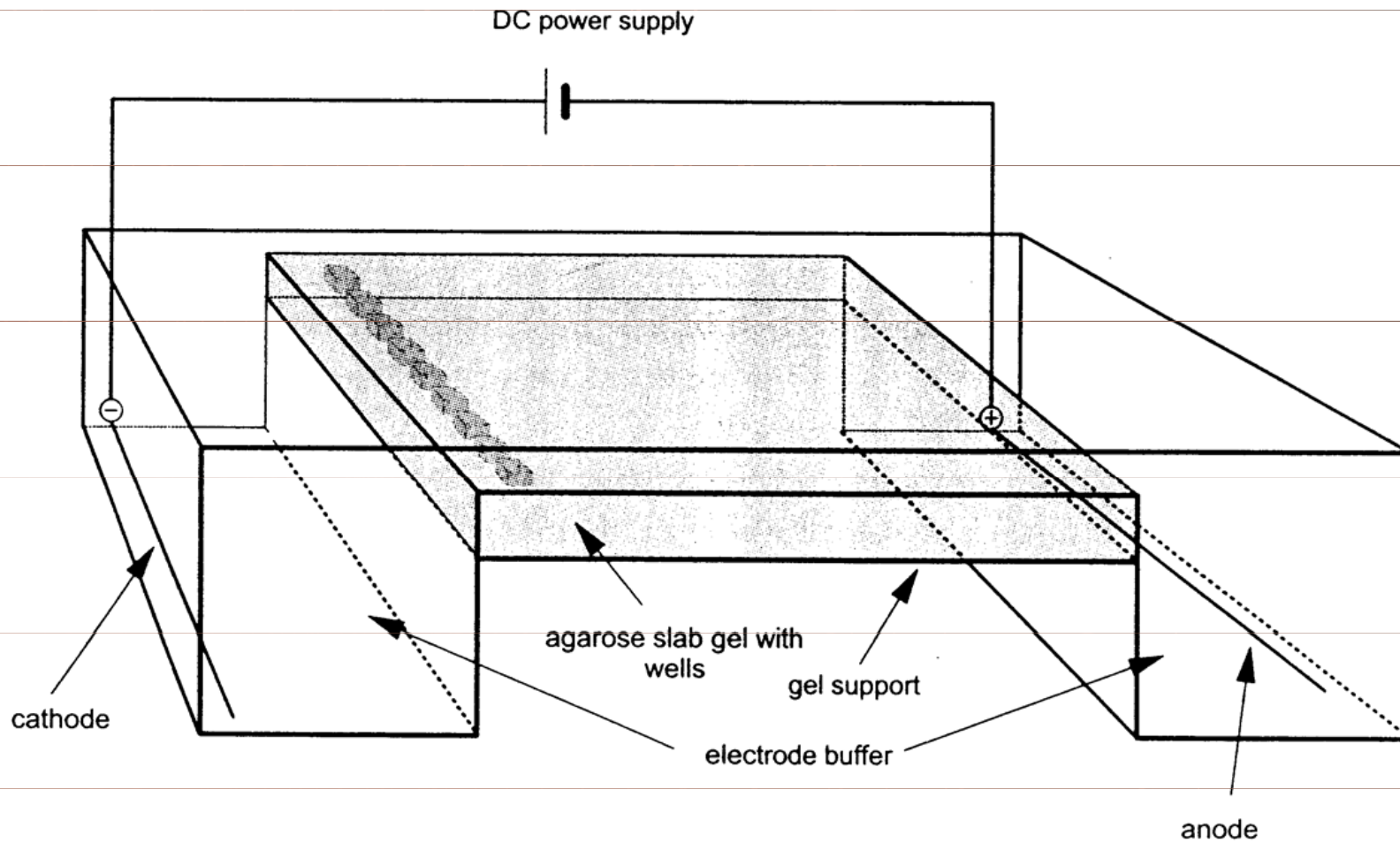

Agar a agarosa



DNA agarosová elektroforéza

Ethidiumbromid - červeně, která v roztoku fluoreskuje pouze slabě, intenzita fluorescence se výrazně zvyšuje vazbou na DNA interkalací mezi páry bází. Excitace při 302 nm, červeno-oranžová emise při 510 nm. Velmi toxická látka!

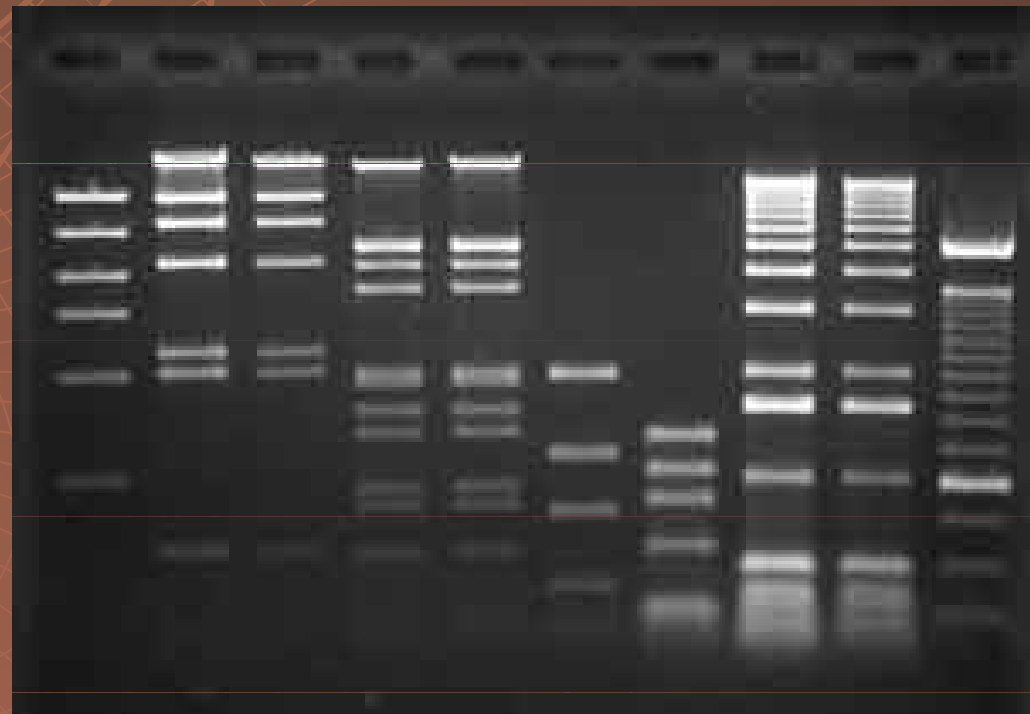
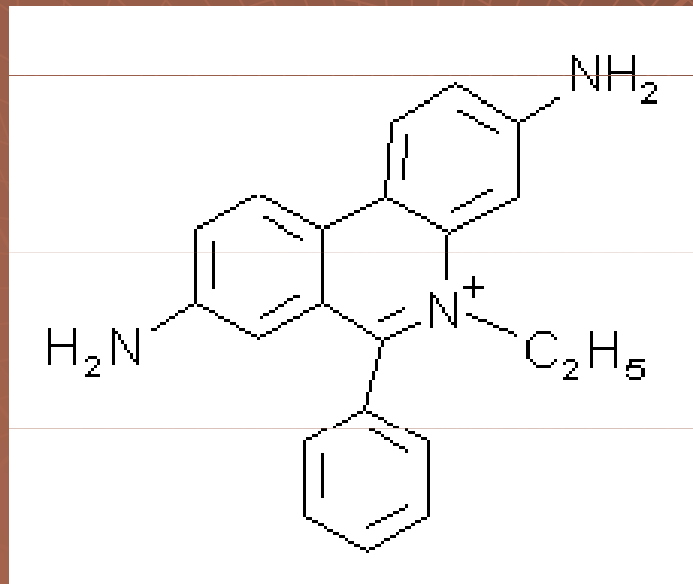

Pulsní DNA elektroforéza

20 000 – 12 000 000 pb

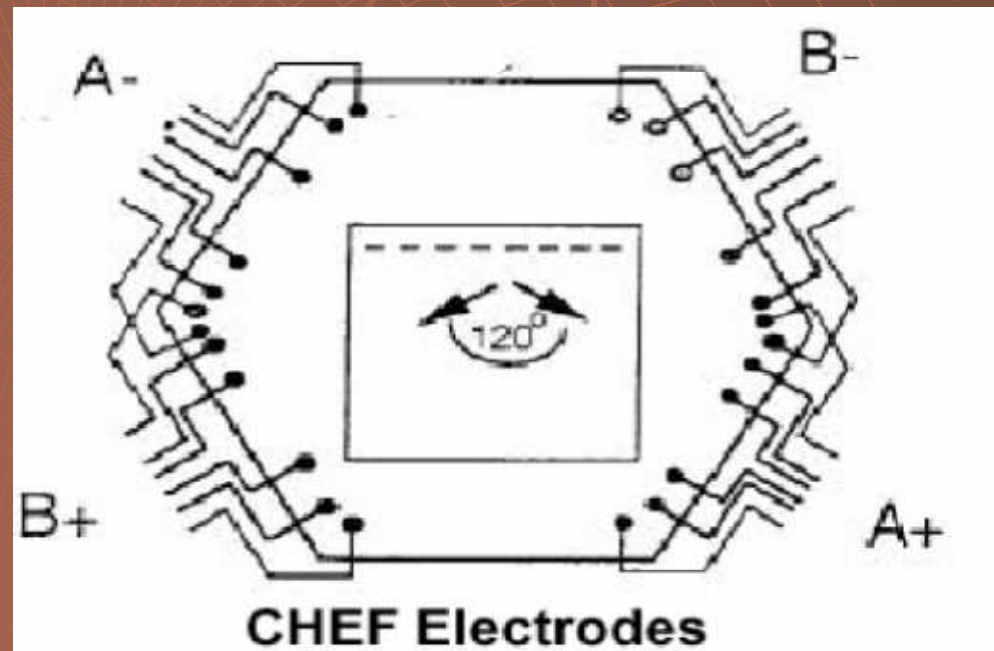
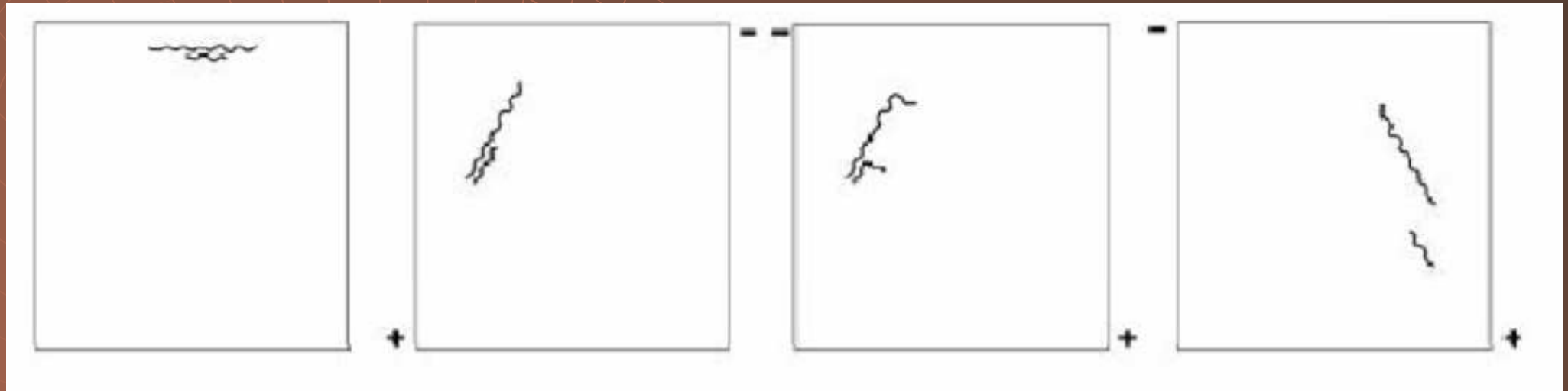

Pulsní DNA elektroforéza

20 000 – 12 000 000 pb

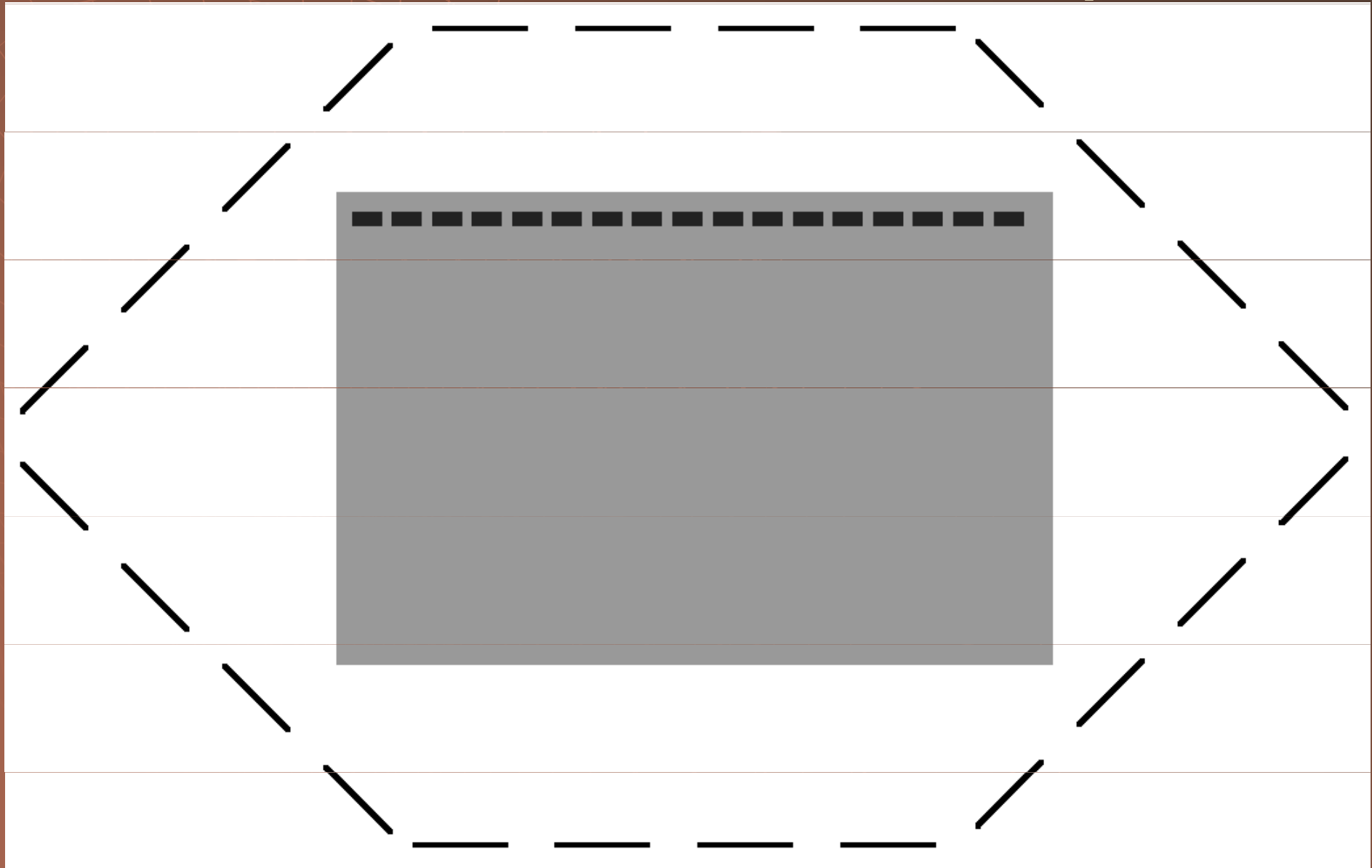

Pulsní DNA elektroforéza

20 000 – 12 000 000 pb

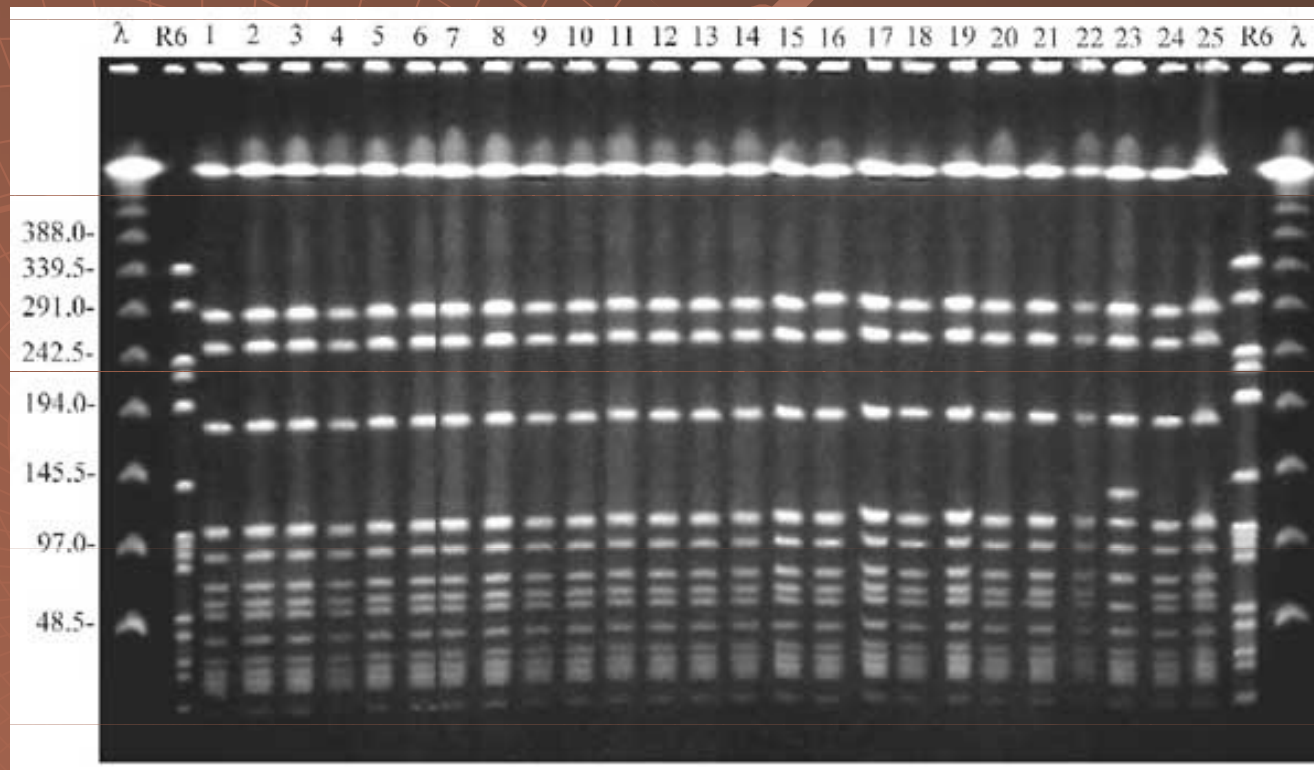

Imunoelektroforéza zónová elektroforéza + difuze

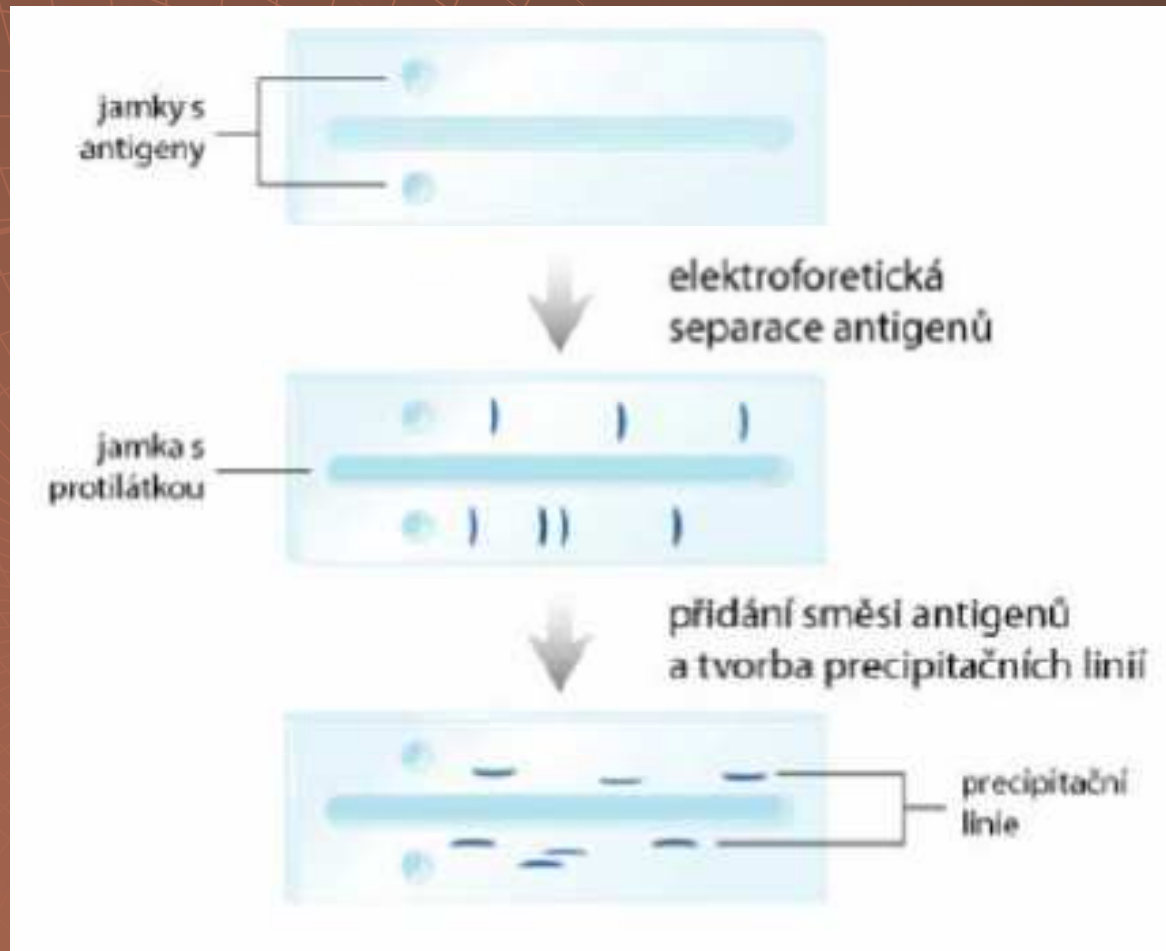

Imunoelektroforéza raketová

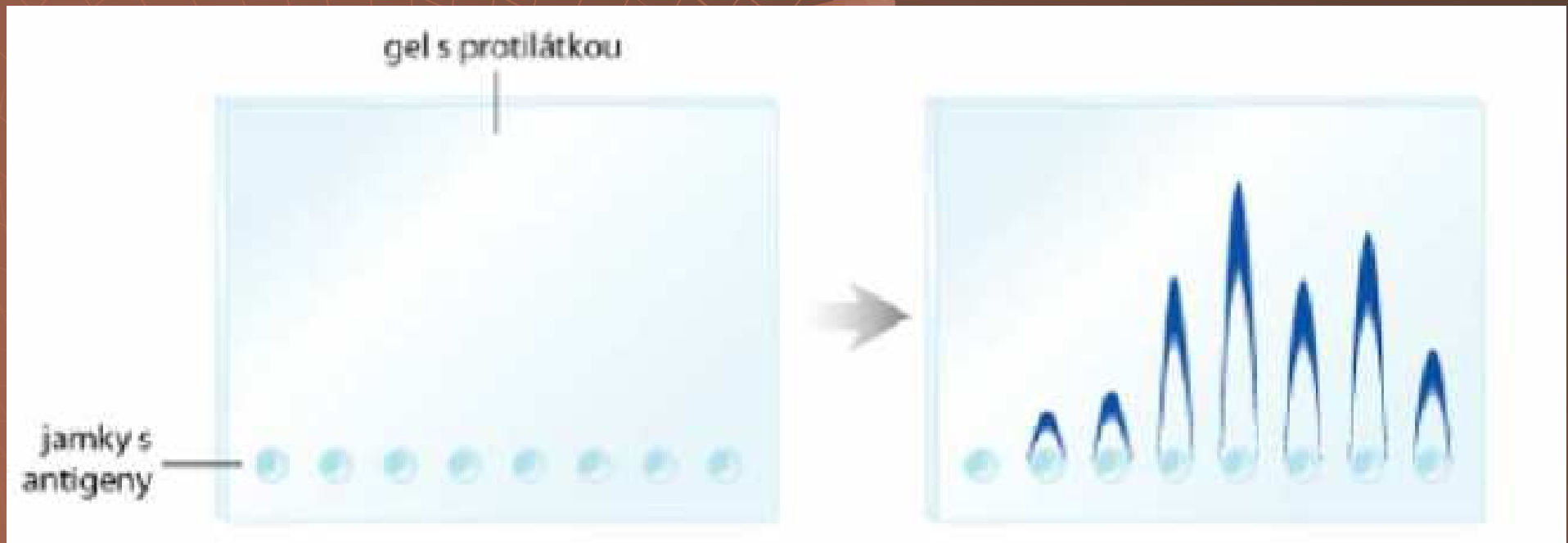

Škrob

Složení – hydrolyzovaný škrob

- + poprvé se uplatňuje efekt molekulového síta
- Špatné mechanické vlastnosti
- Komplikovaná a nereprodukovatelná příprava
- Není transparentní

Použití : izoenzymová analýza

Sypané vrstvy

Složení – Sephadex – zesíťovaný dextran

+ uplatňuje efekt molekulového síta

Použití : preparativní

Polyakrylamid

Složení – kopolymer akrylamidu a
N,N,- methylenbisakrylamidu

+ plně splňuje požadavky

- Monomery jsou neurotoxiny !!!!!

Použití : analýza bílkovin a NK

Polyakrylamid

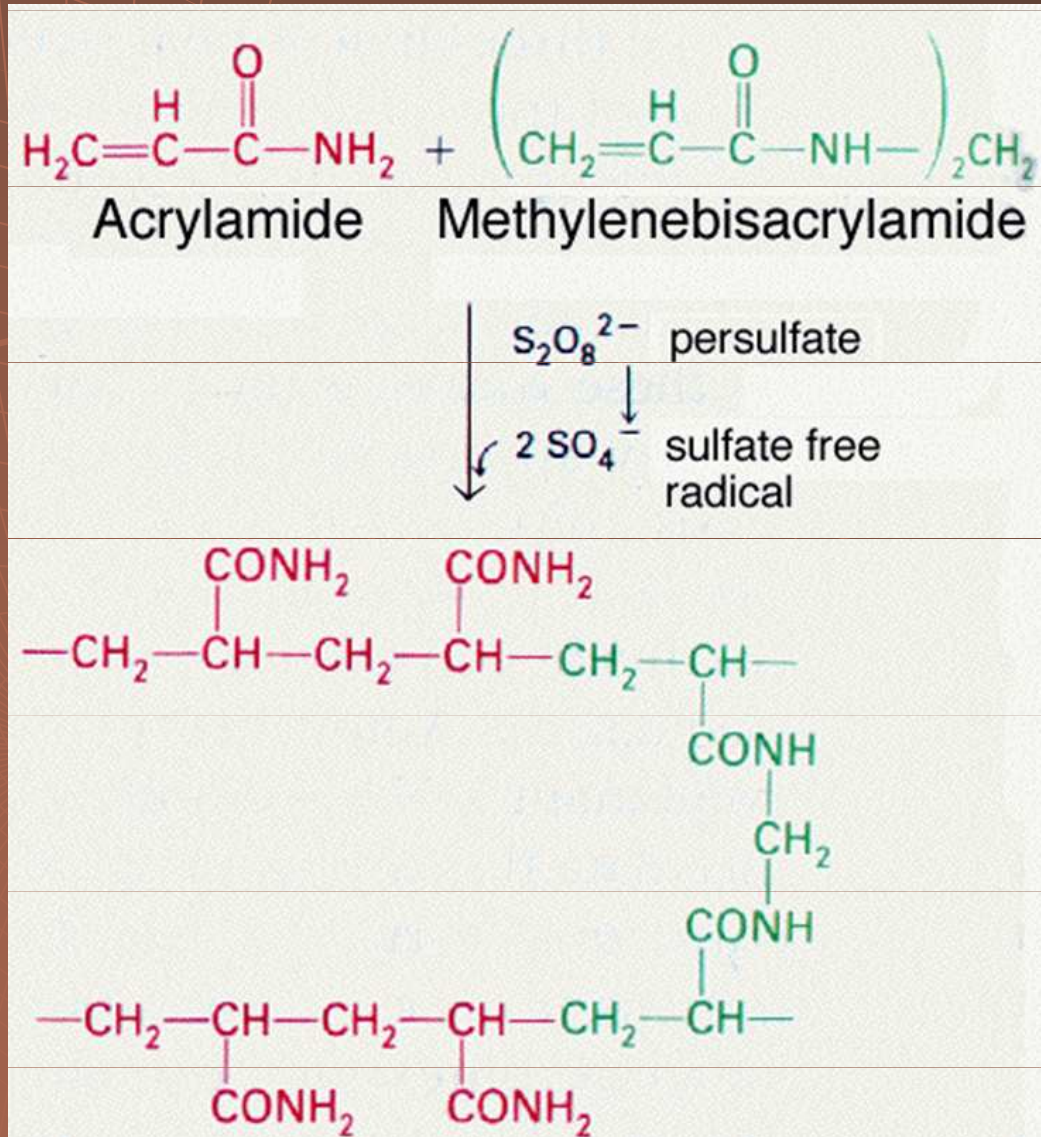

Polyakrylamid - příprava

Radikálová polymerace

- ◆ Katalyzátor – tetramethylethylenediamin
TEMED
- ◆ Iniciátor - chemicky – $(\text{NH}_4)_2\text{S}_2\text{O}_8$
- fotochemicky – ribloflavin + UV

Polyakrylamid - složení

$$T = \frac{a + b}{m} \times 100\%$$

$$C = \frac{b}{a + b} \times 100\%$$

a – akrylamid (g)

b – methylenbisakrylamid (g)

m – objem (ml)

Fergussonova rovnice

PAGE není pouze pasivním nosičem, ale podílí se na separaci efektem molekulového síta.

$$\log \mu = \log \mu_0 + K_r [T]$$

μ - mobilita

μ_0 - mobilita při limitním zředění

K_r - retardační koeficient

Uplatnění Fergussonovy rovnice

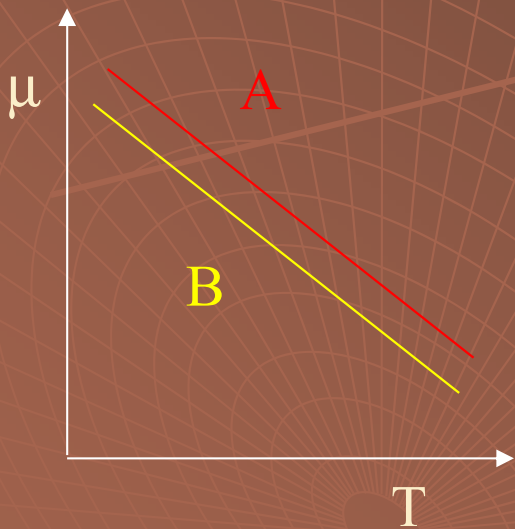

$$\begin{aligned} Mr_A &= Mr_B \\ pI_A &\neq pI_B \end{aligned}$$

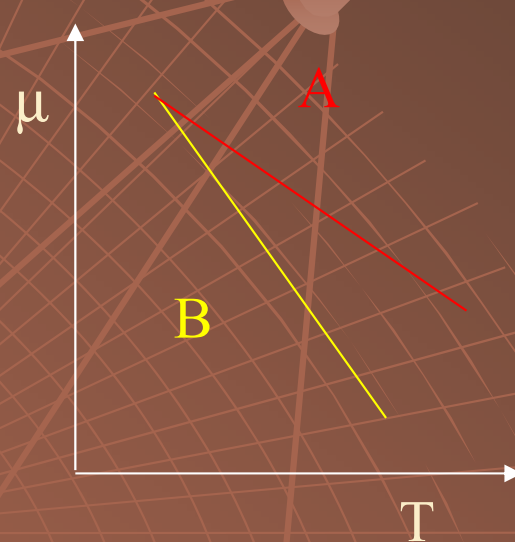

$$\begin{aligned} Mr_A &\neq Mr_B \\ pI_A &= pI_B \end{aligned}$$

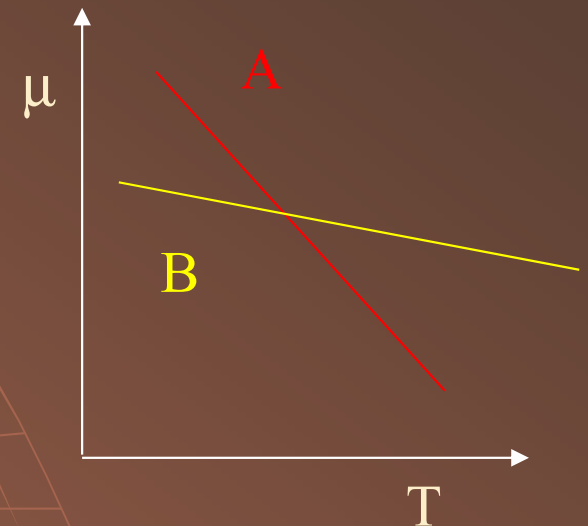

$$\begin{aligned} Mr_A &\neq Mr_B \\ pI_A &\neq pI_B \end{aligned}$$

Provedení PAGE

vertikální x horizontální
deskové x trubičkové
homogenní x gradientové
kontinuální x diskontinuální
nativní x SDS PAGE

Upořádání

Horizontální

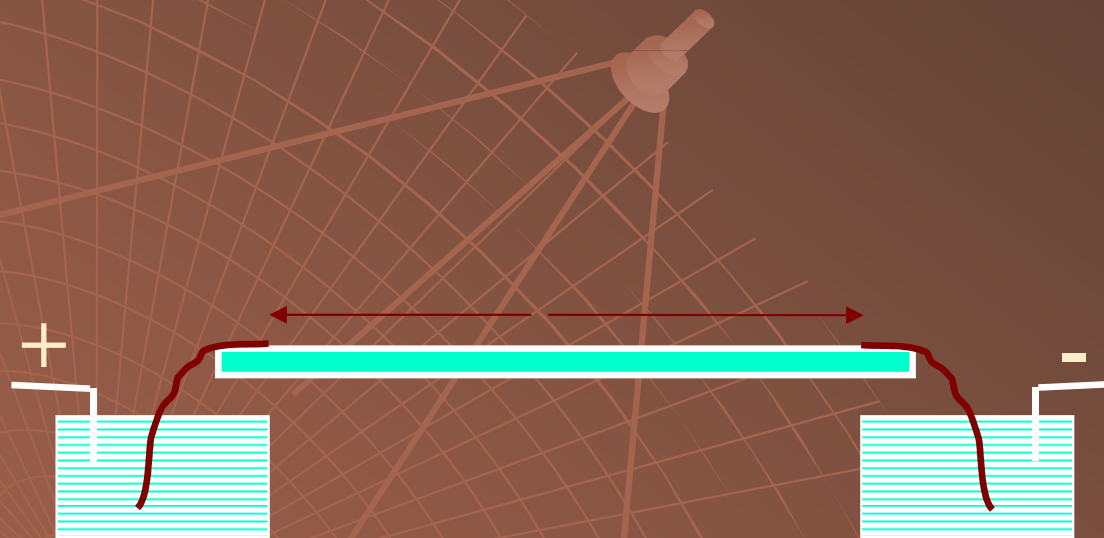

Upořádání

Vertikální

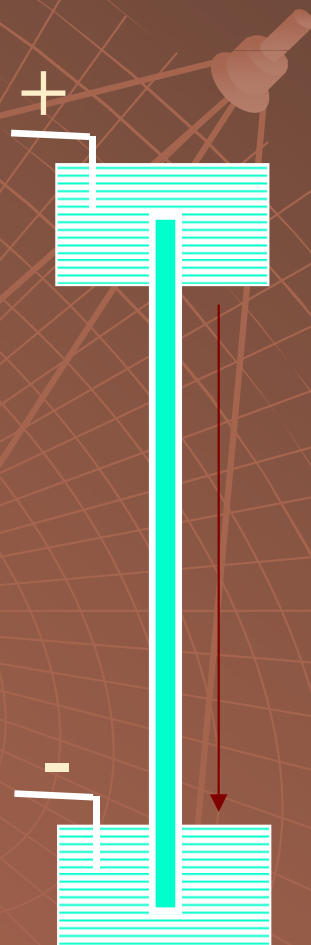

Provedení PAGE deskové x trubičkové

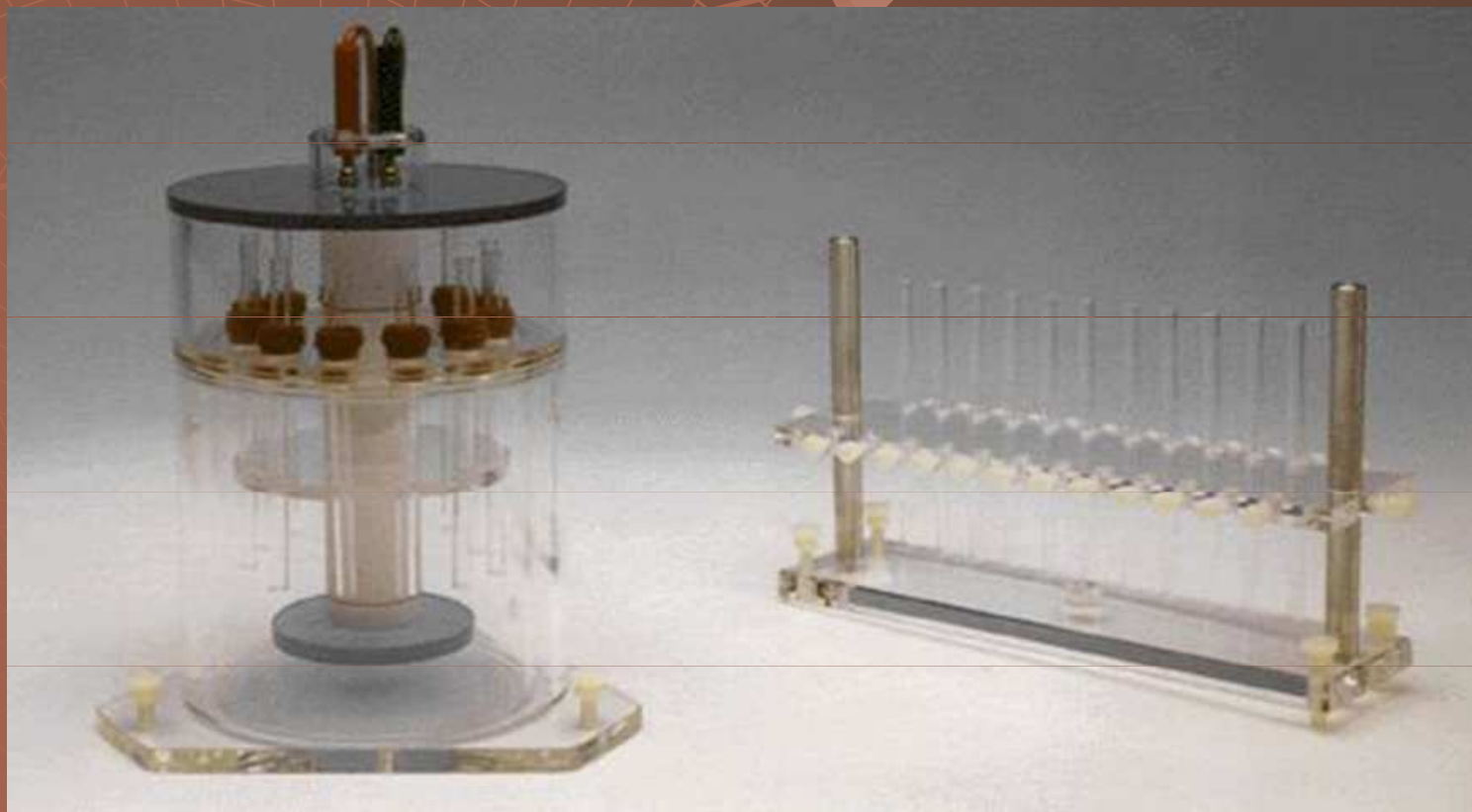

Provedení PAGE deskové x trubičkové



Provedení PAGE deskové x trubičkové

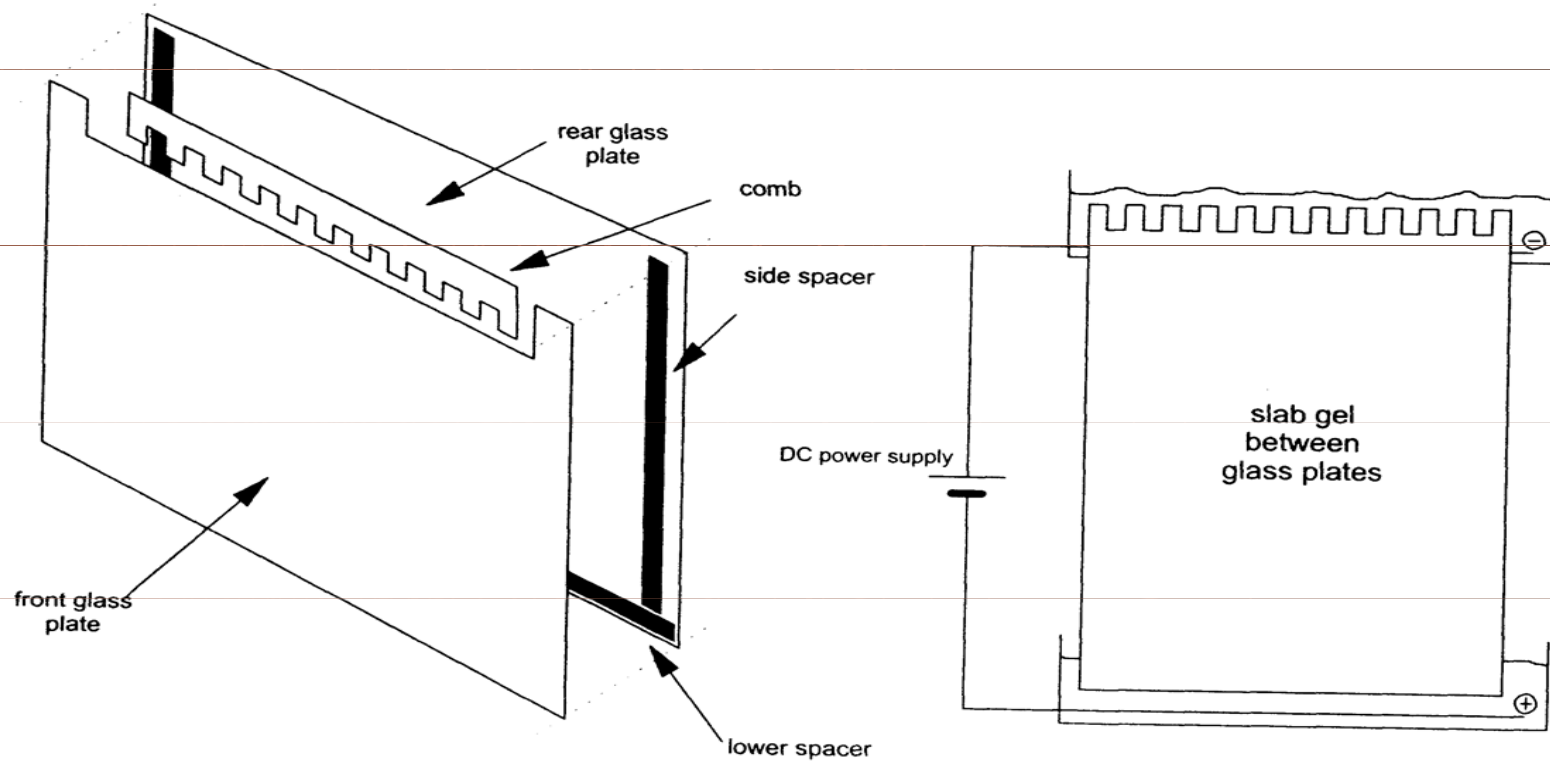

gel cassette

electrophoresis apparatus

Provedení PAGE deskové x trubičkové

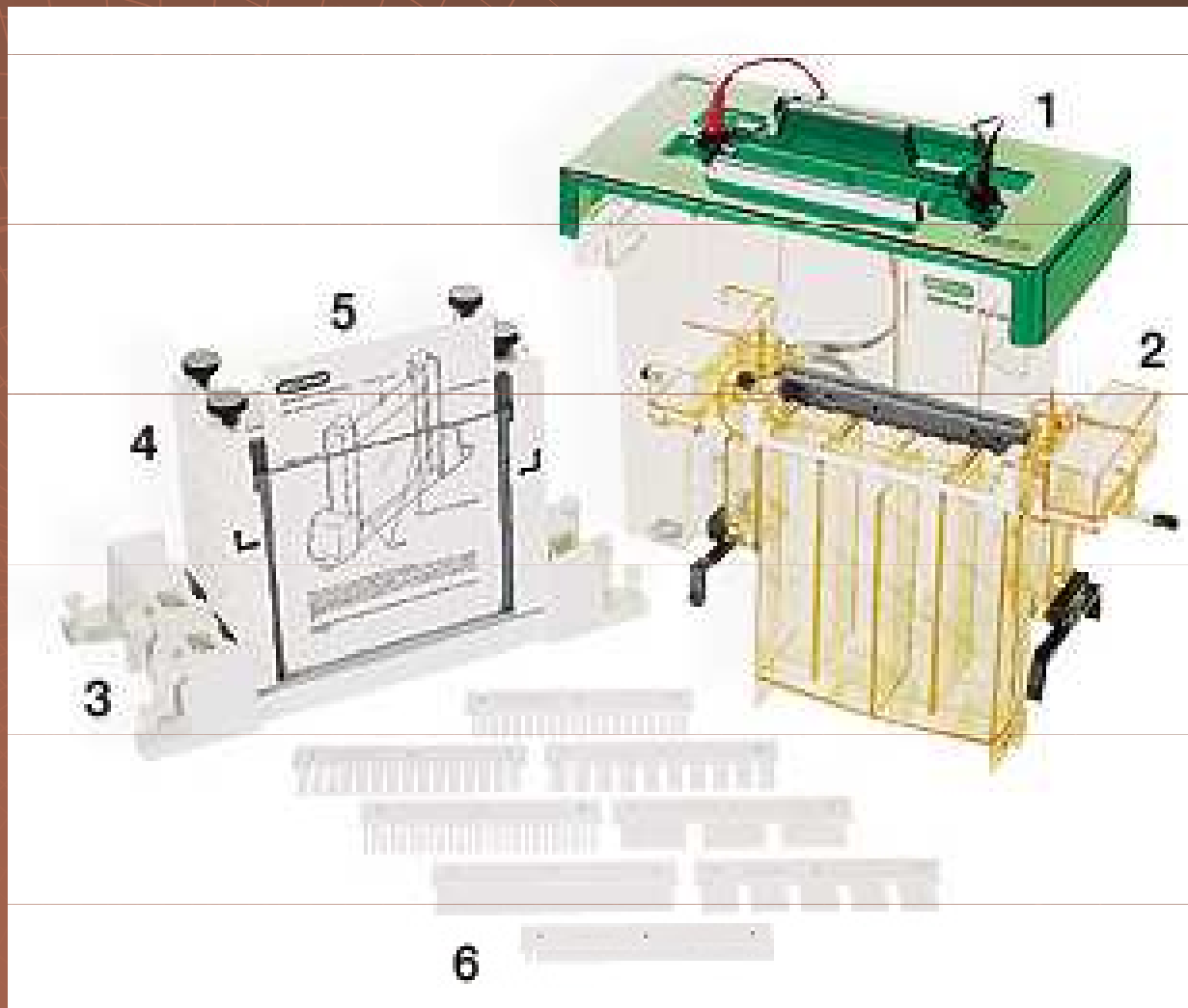

Provedení PAGE deskové x trubičkové

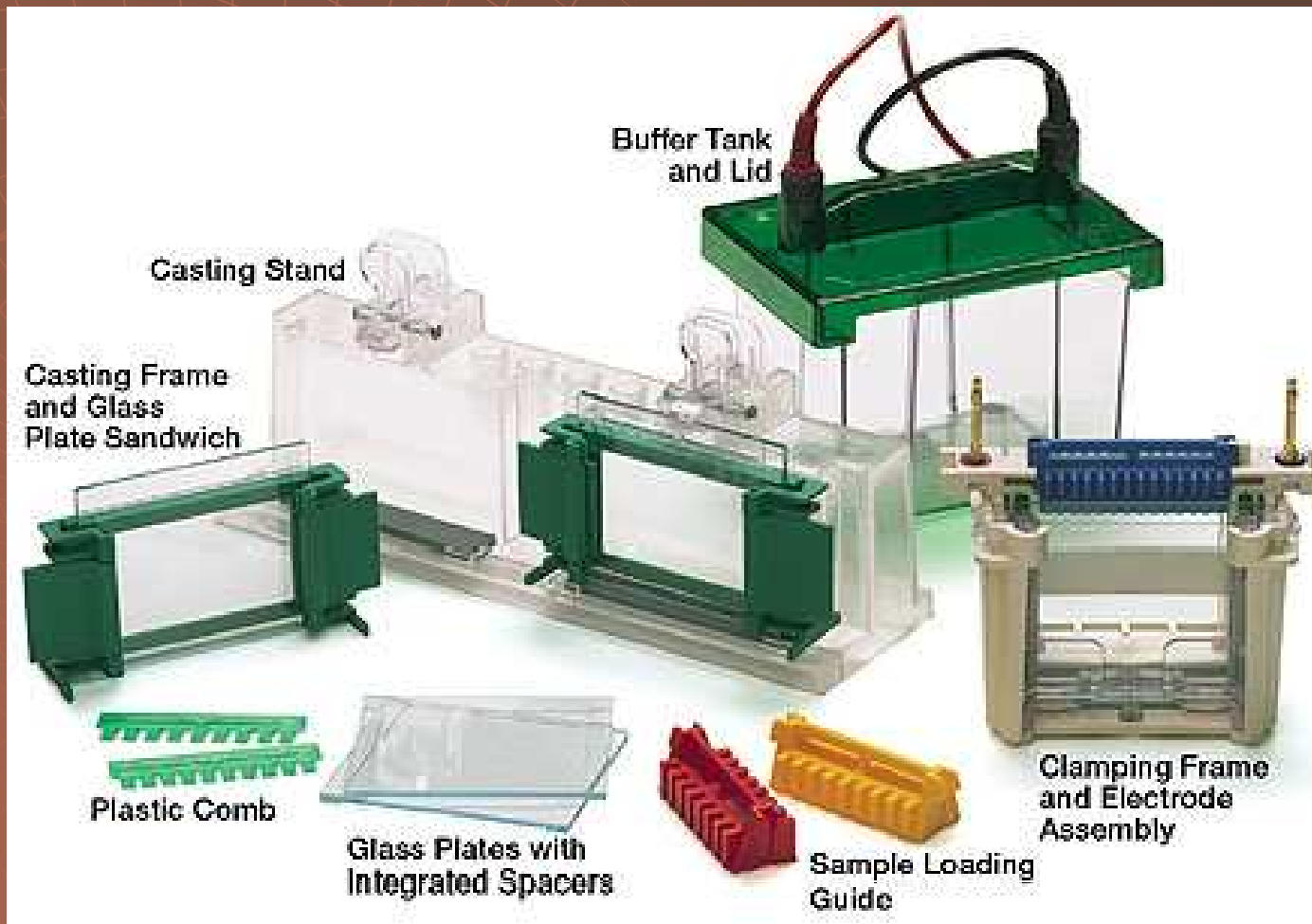

Provedení PAGE

homogenní x gradientové

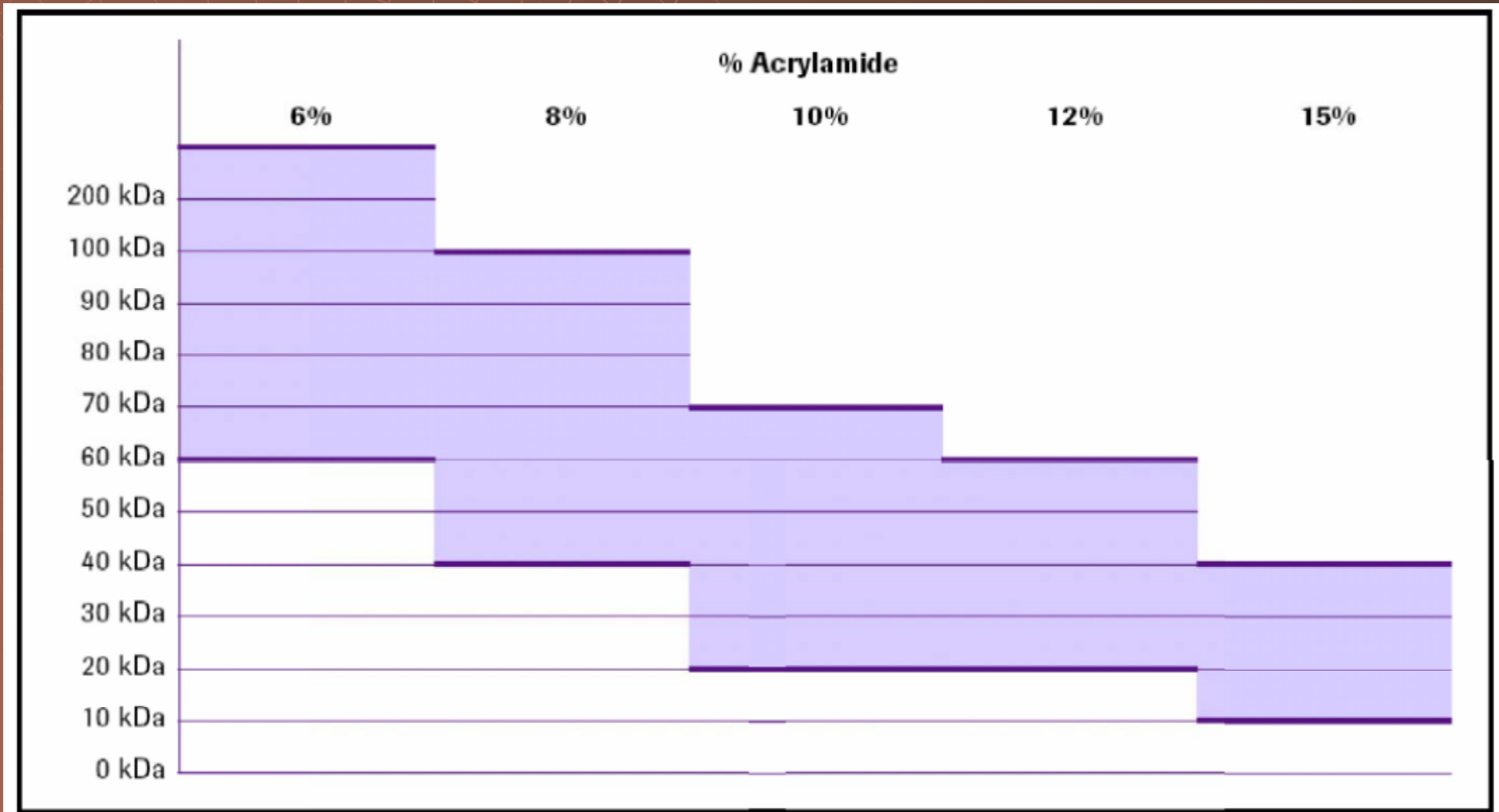

Provedení PAGE

homogenní x gradientové

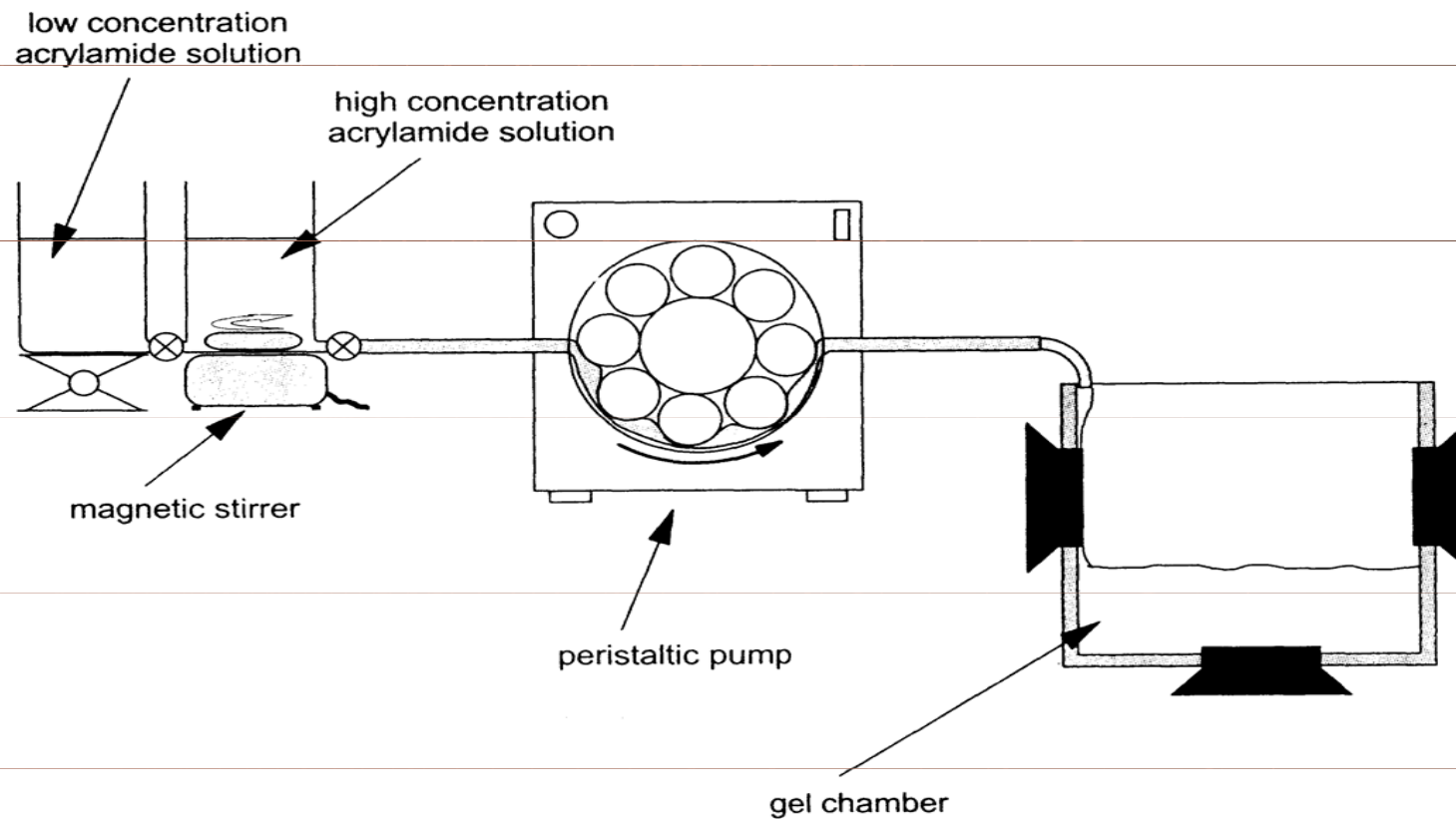

Provedení PAGE

homogenní x gradientové

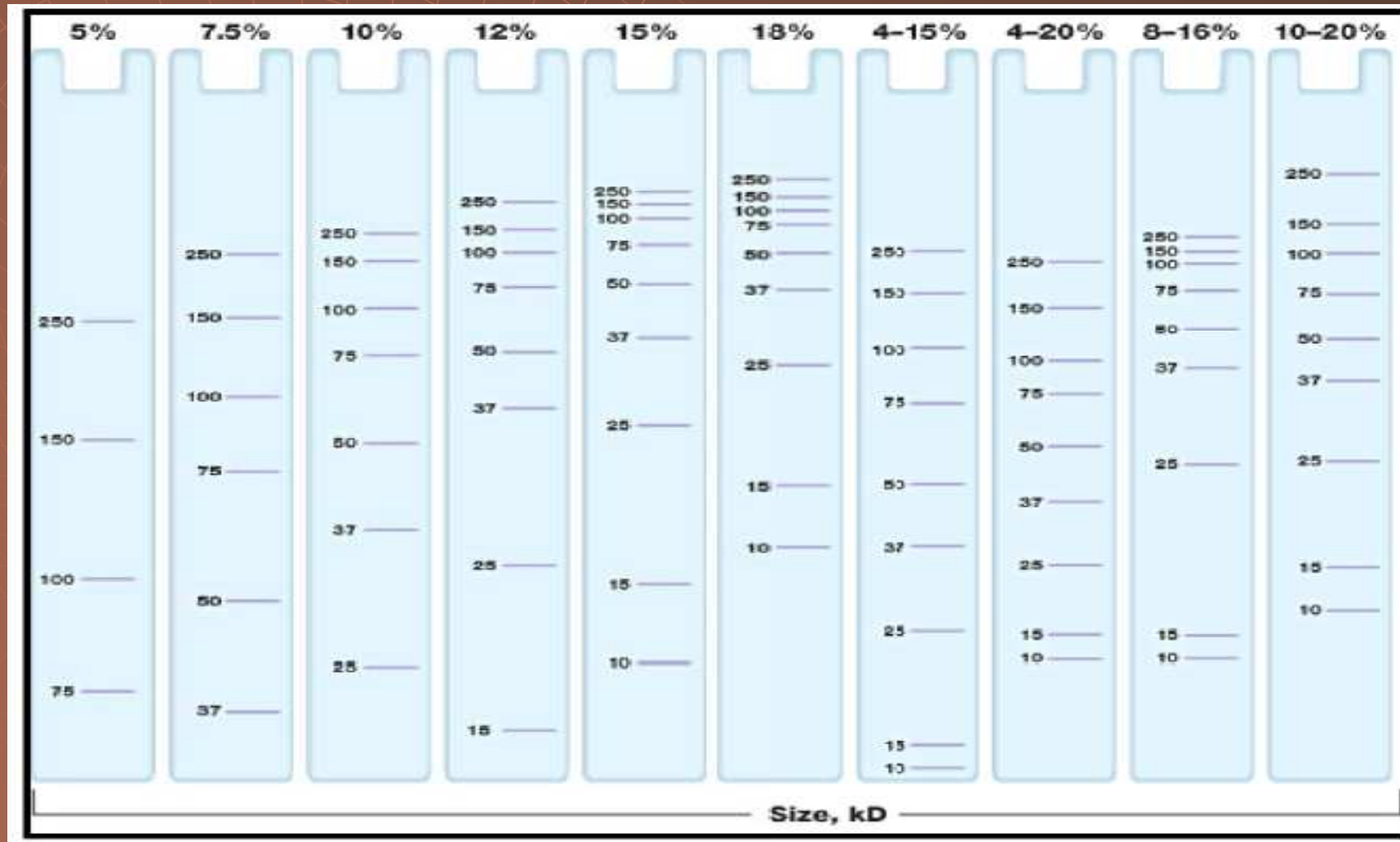

Provedení PAGE

kontinuální x diskontinuální

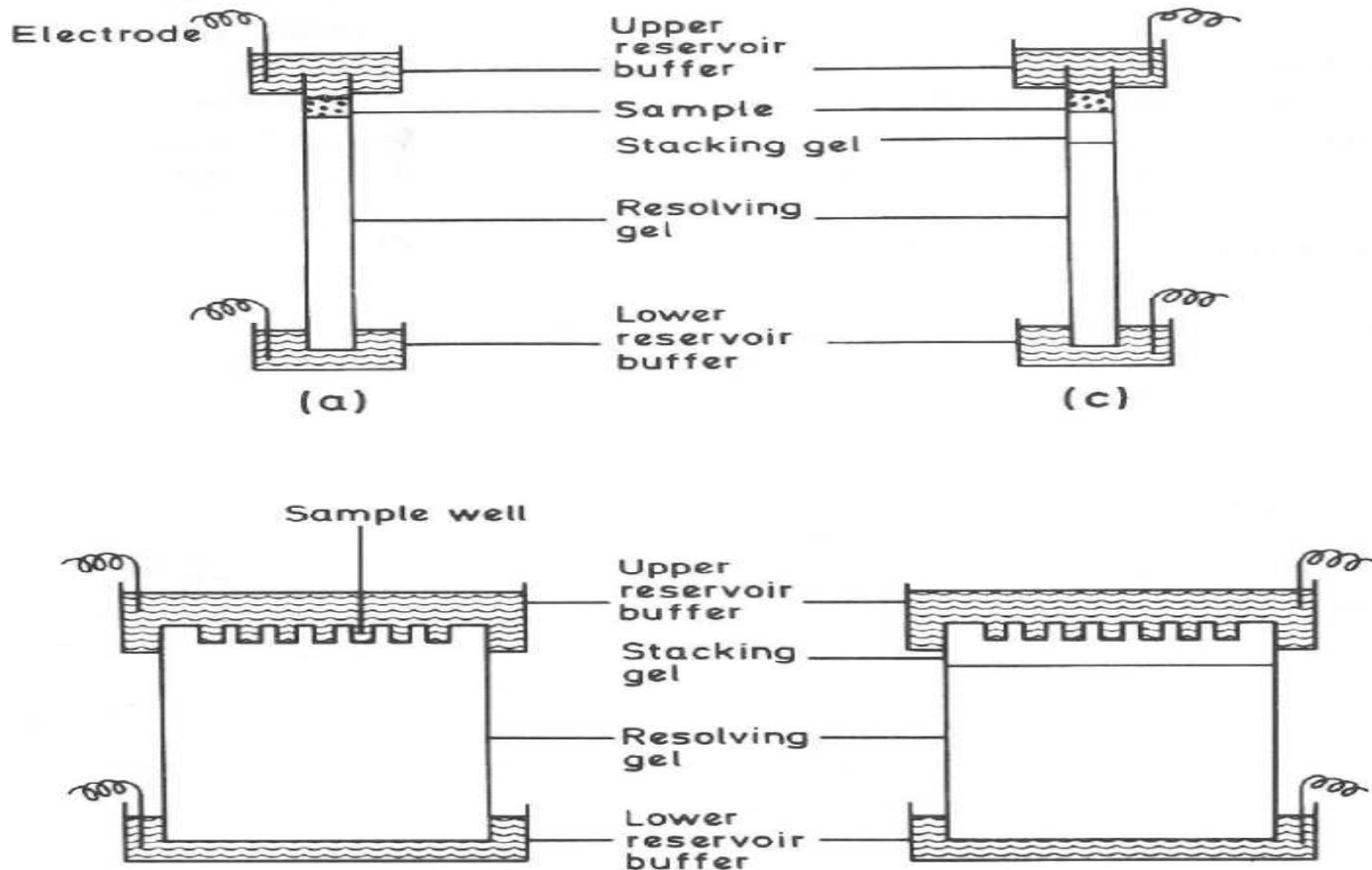

Diskontinuální PAGE

Orstein, Davis

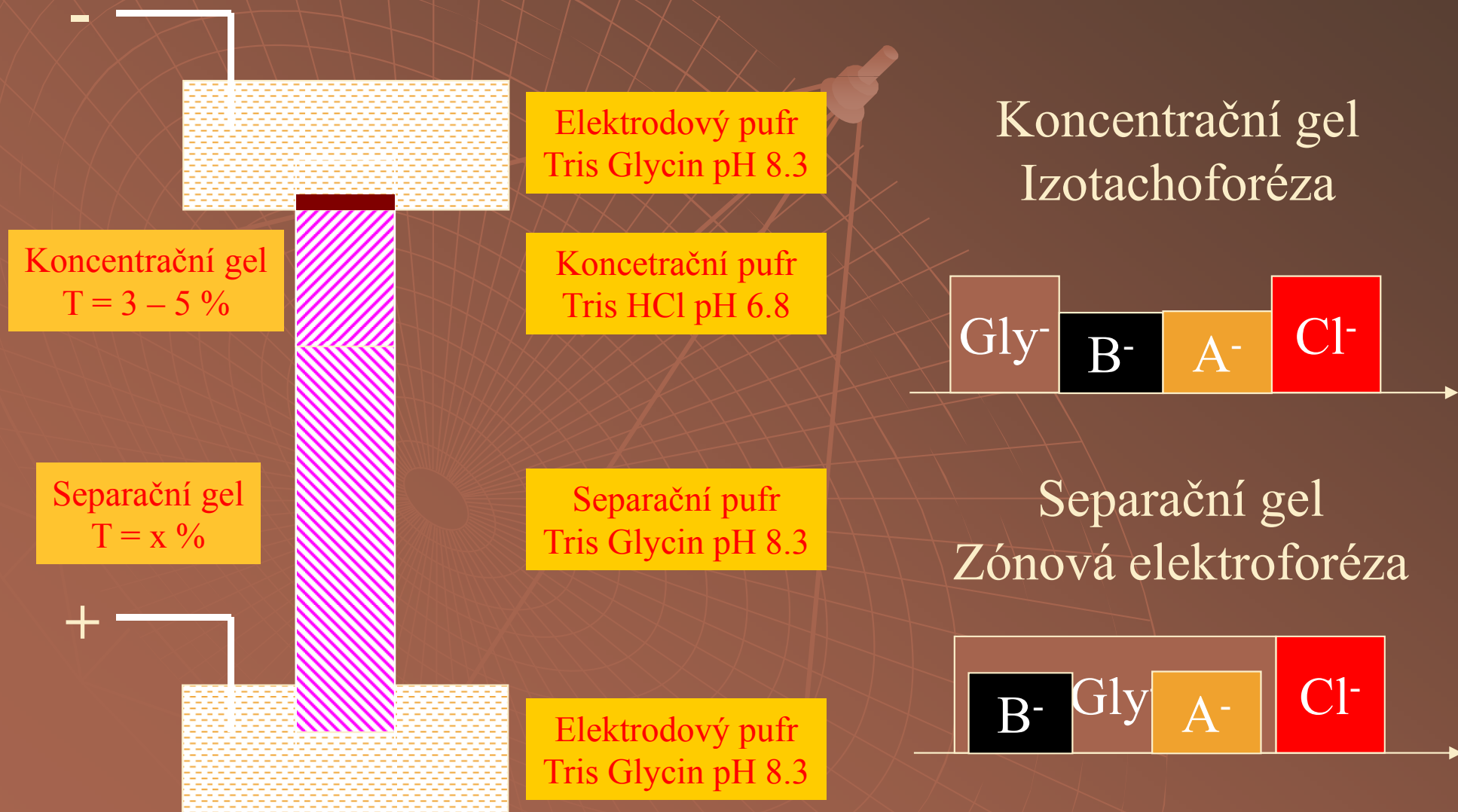

Diskontinuální PAGE

Orstein, Davis

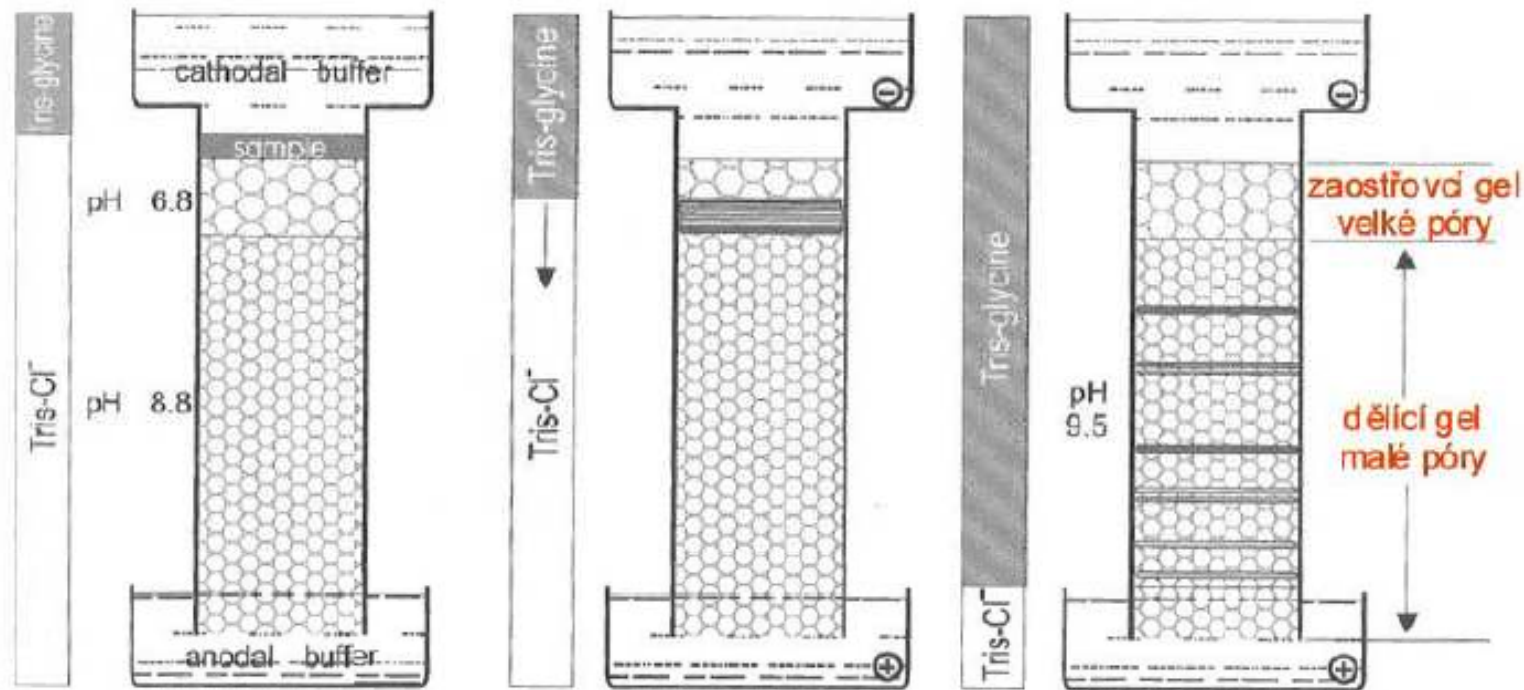

princip zaostřování

SDS PAGE

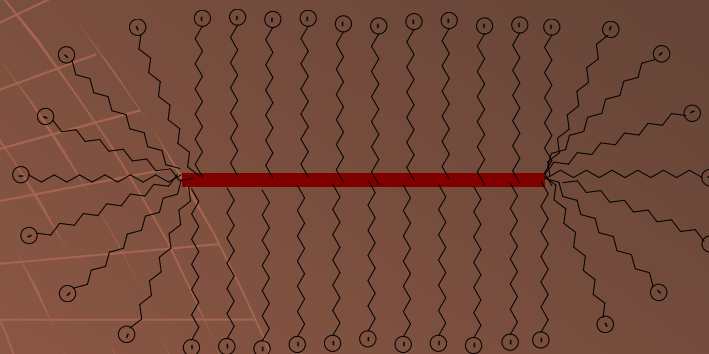
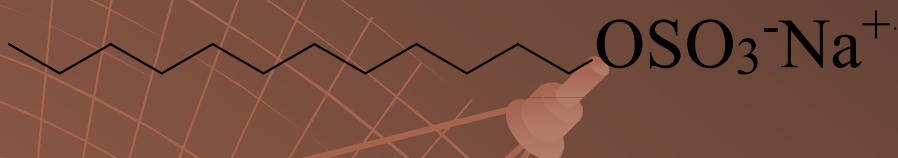
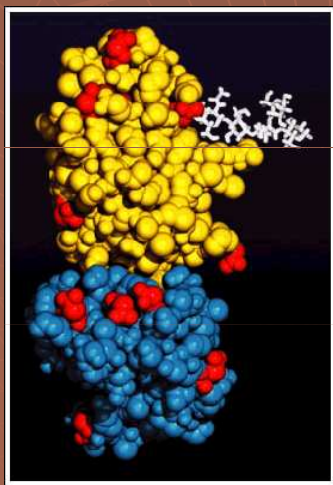

1 g bílkoviny váže 1.4 g SDS \Rightarrow
uniformní náboj na jednotku MW

SDS PAGE

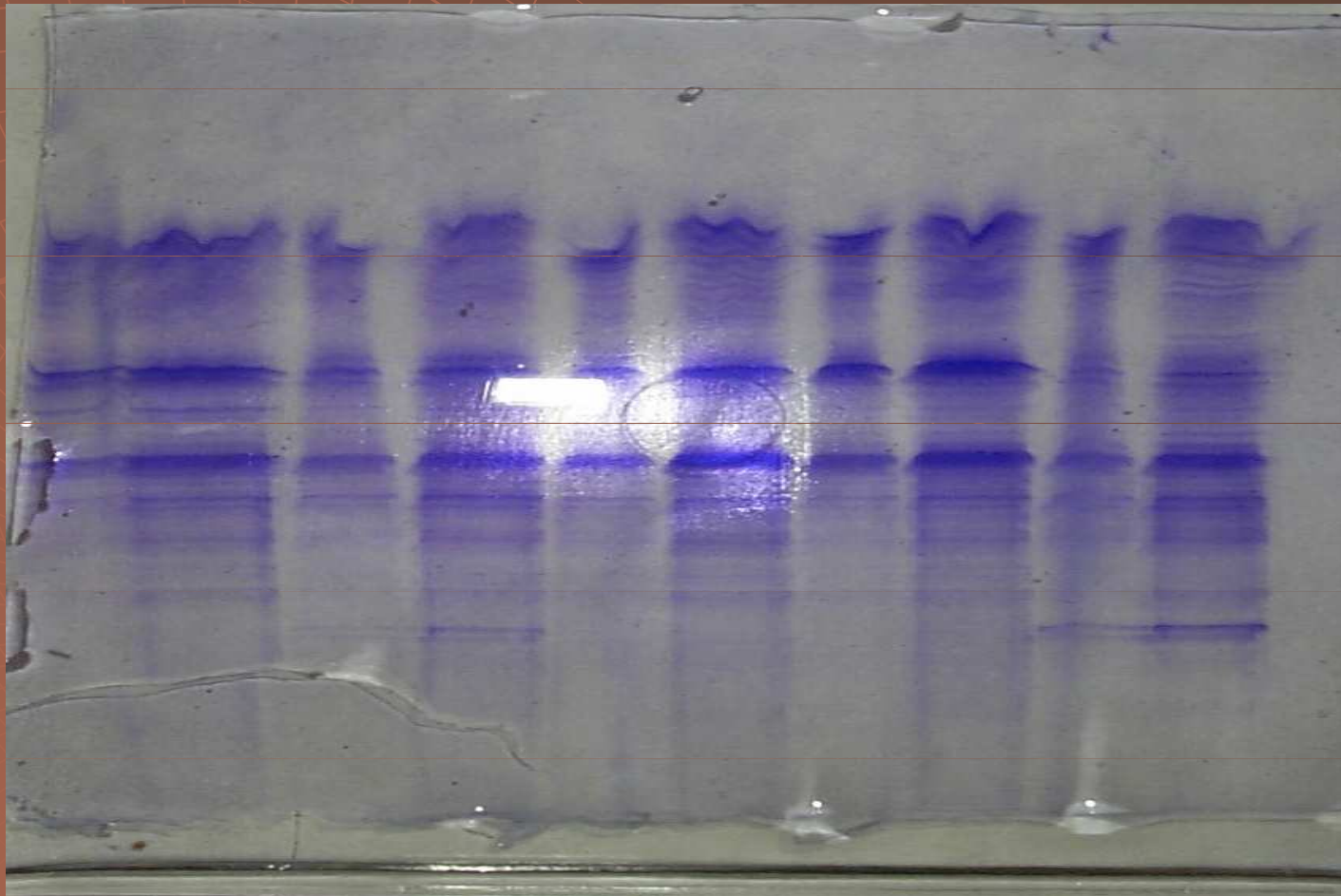

Stanovení M_r pomocí SDS PAGE

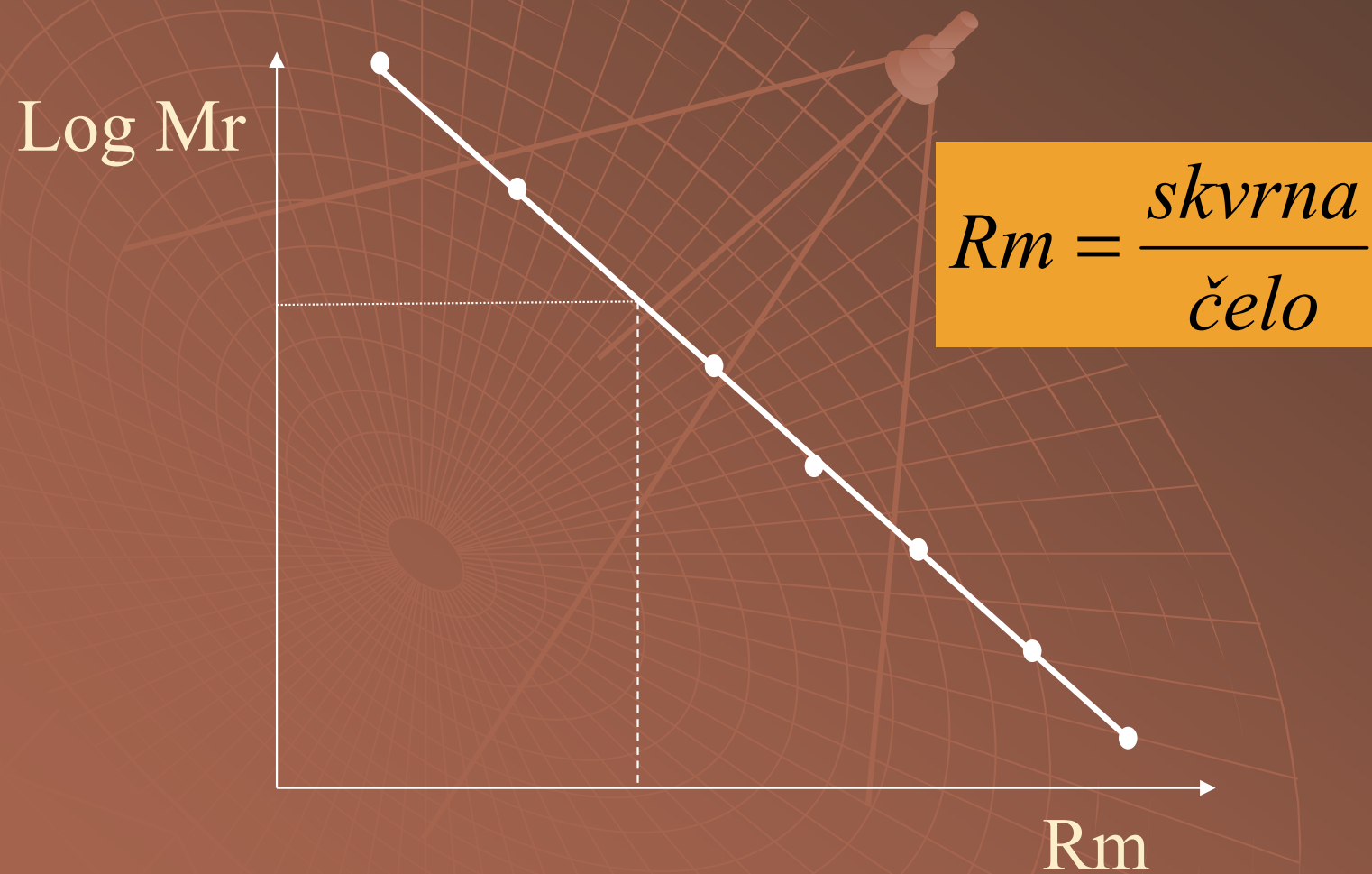

Stanovení Mr pomocí SDS PAGE - standardy

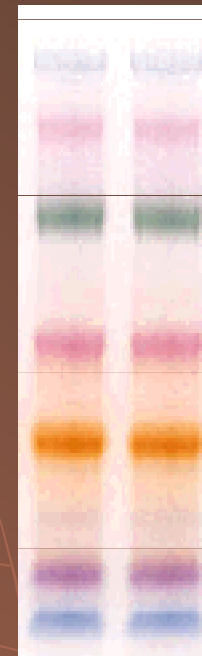
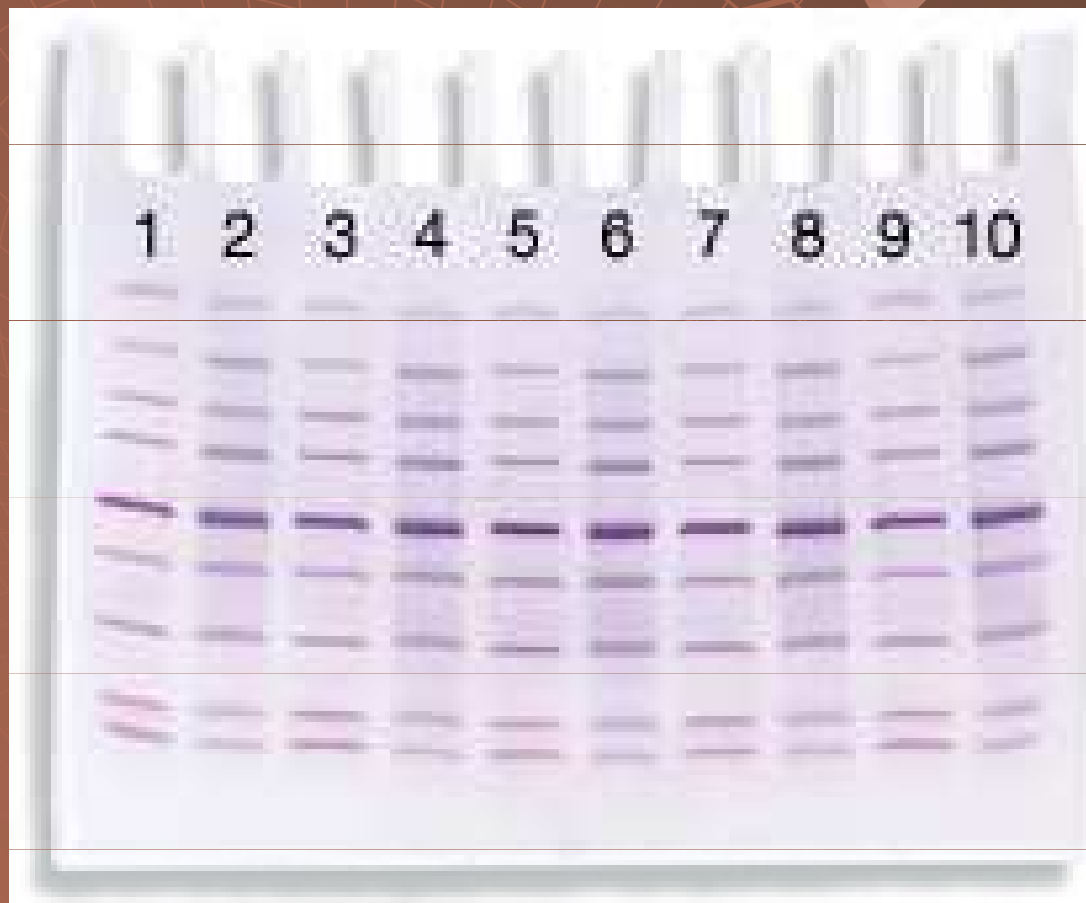

Použití SDS PAGE

- ◆ Stanovení M_r
- ◆ Analýza komplexních směsí
- ◆ Sledování purifikace bílkovin
- ◆ Stanovení podjednotkového složení

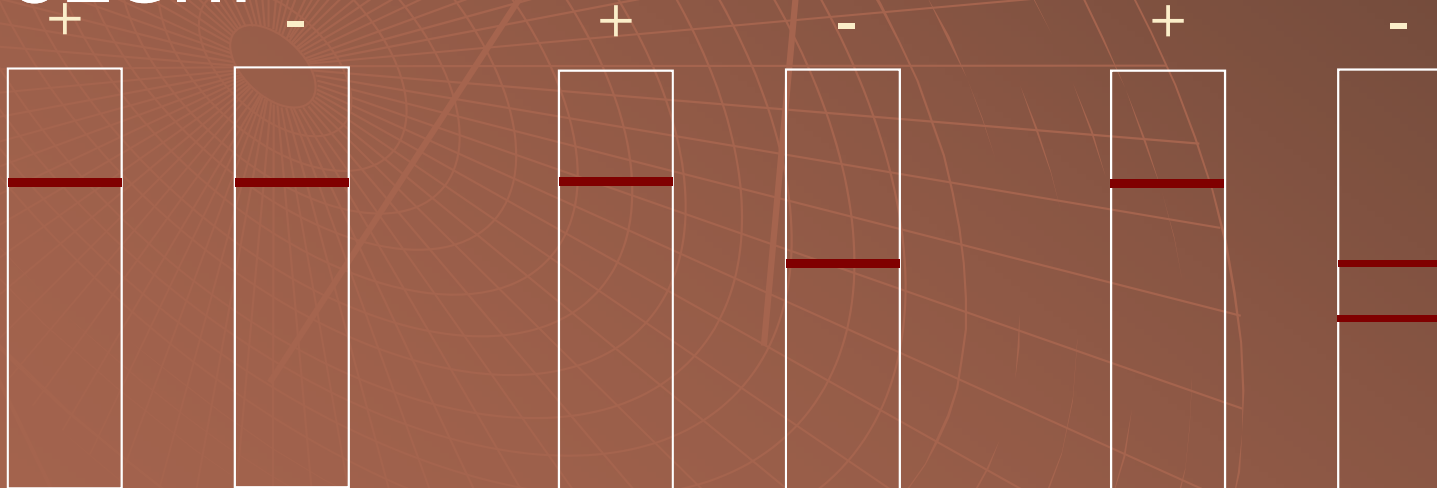

Stanovení Mr pomocí SDS redukcující x neredukující

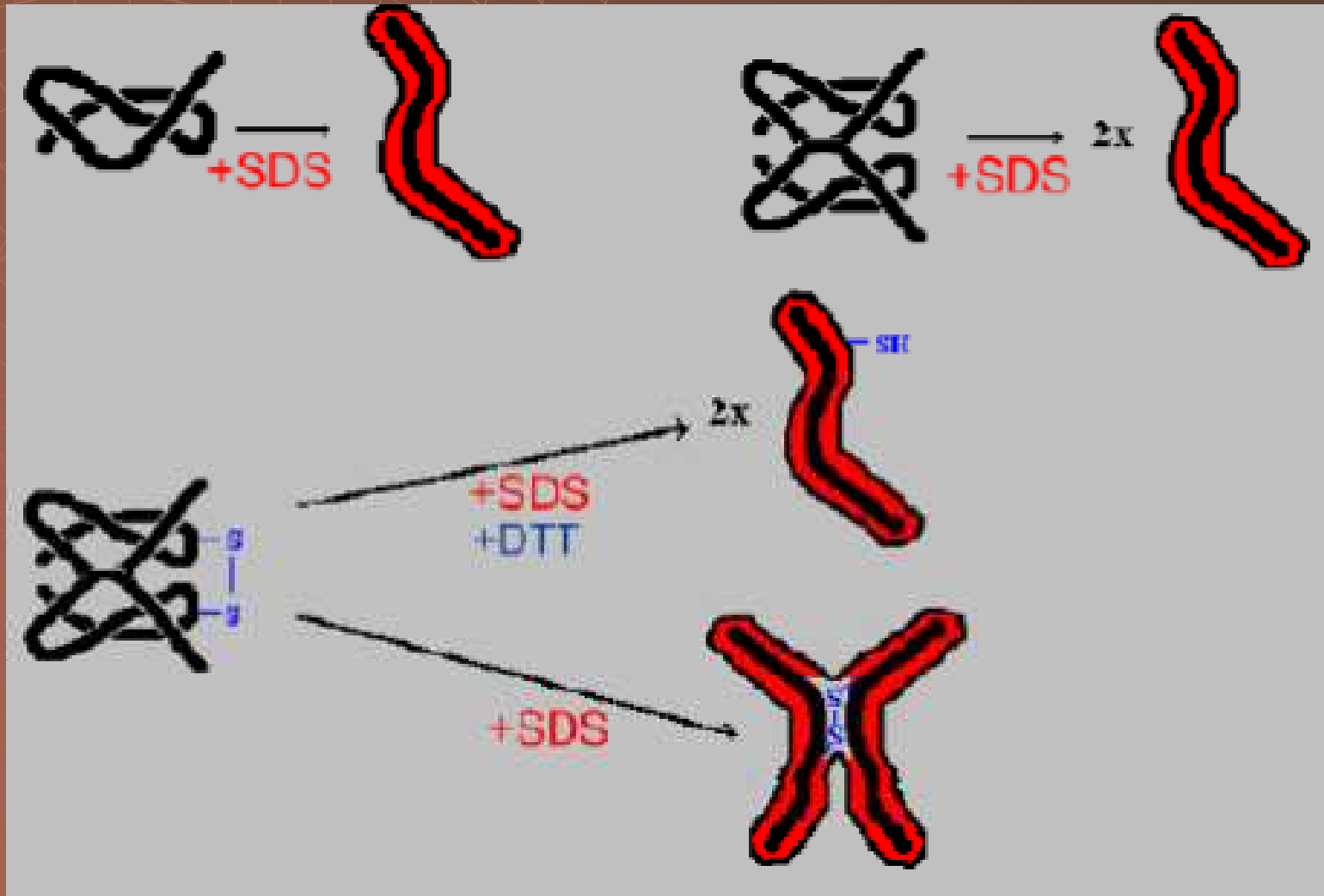

PAGE - sekvenace DNA

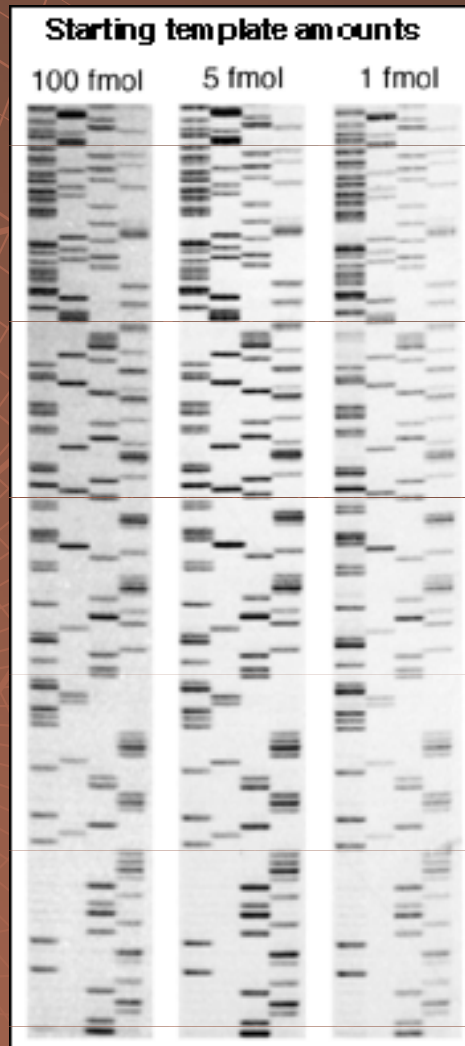

Chemická metoda

Maxam-Gilbertova metoda

- značení 5' konce ^{32}P
- specifické chemické štěpení
- elektroforéza

BÁZE

G

G + A

C

C + T

CHEMIKÁLIE

dimethylsufoxid+ piperidin

dimethylsufoxid+ piperidin +
k.mravenčí

hydrazin/chlorid sodný+ piperidin

hydrazin + piperidin

Vzorek DNA

1 Příprava homogenní jednovláčkové DNA

5'ATTGACTTAGCC3'

2 radioaktivní značka na 5' konci

*ATTGACTTAGCC

3 stepení na specifické nukleotidy

G

A
+
G

T
+
C

C

*ATTGACTTAGCC
*ATTGACTTA
*ATT

*ATTGACTTAGCC
*ATTGACTTA
*ATTGACTT
*ATTG
*ATT

*ATTGACTTAGCC
*ATTGACTTAGC
*ATTGACTTAG
*ATTGACT
*ATTGAC
*ATTGA
*AT
*A

*ATTGACTTAGCC
*ATTGACTTAGC
*ATTGACTTAG
*ATTGA

4 Elektroforéza

5 Vizualizace

délka fragmentů

Celý oligonukleotid →

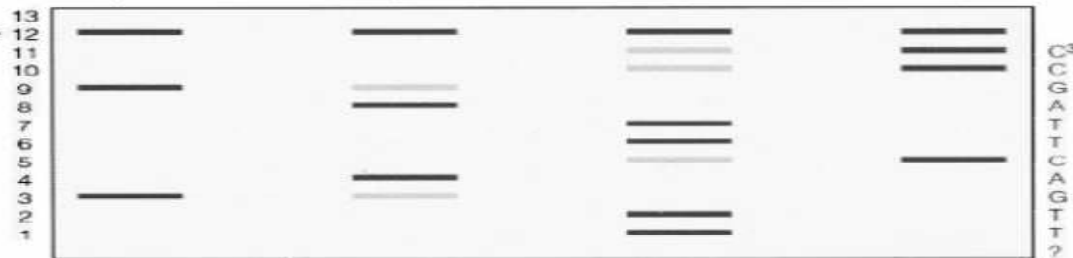

6 čtení sekvence

Enzymová metoda

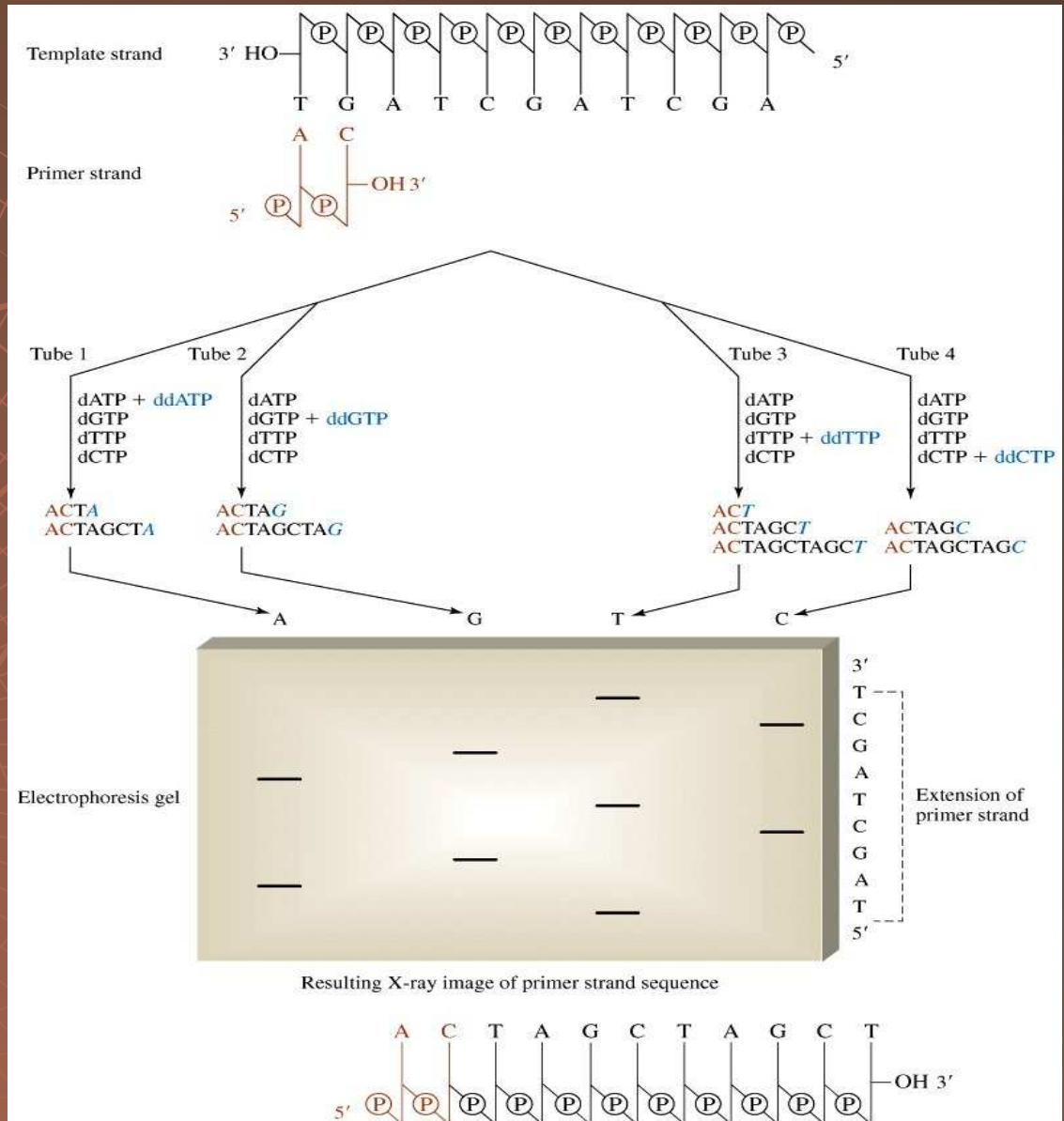
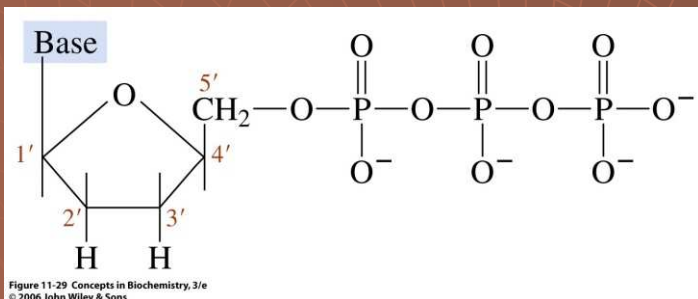

Figure 11-30 Concepts in Biochemistry, 3/e
© 2006 John Wiley & Sons

A G C T

A G C T

140

80

AGGTCTTCTTGG
CTTTATGTTG
GTAACAGATG
GCATTTGAG
ATCTGACTATA
90 TAATAATATG
TCCAAGTTTA

—
—
—
—
—
—
—

—
—
—
—
—
—
—
—

ATTTGAACCT
CAGATAGTAT
TTCCCTGA
CCTGGGAGTT
AACATCCGAA
TGAACCTTTG
TACCCATCAT
TCGTA
TACTTGT

Preparativní PAGE

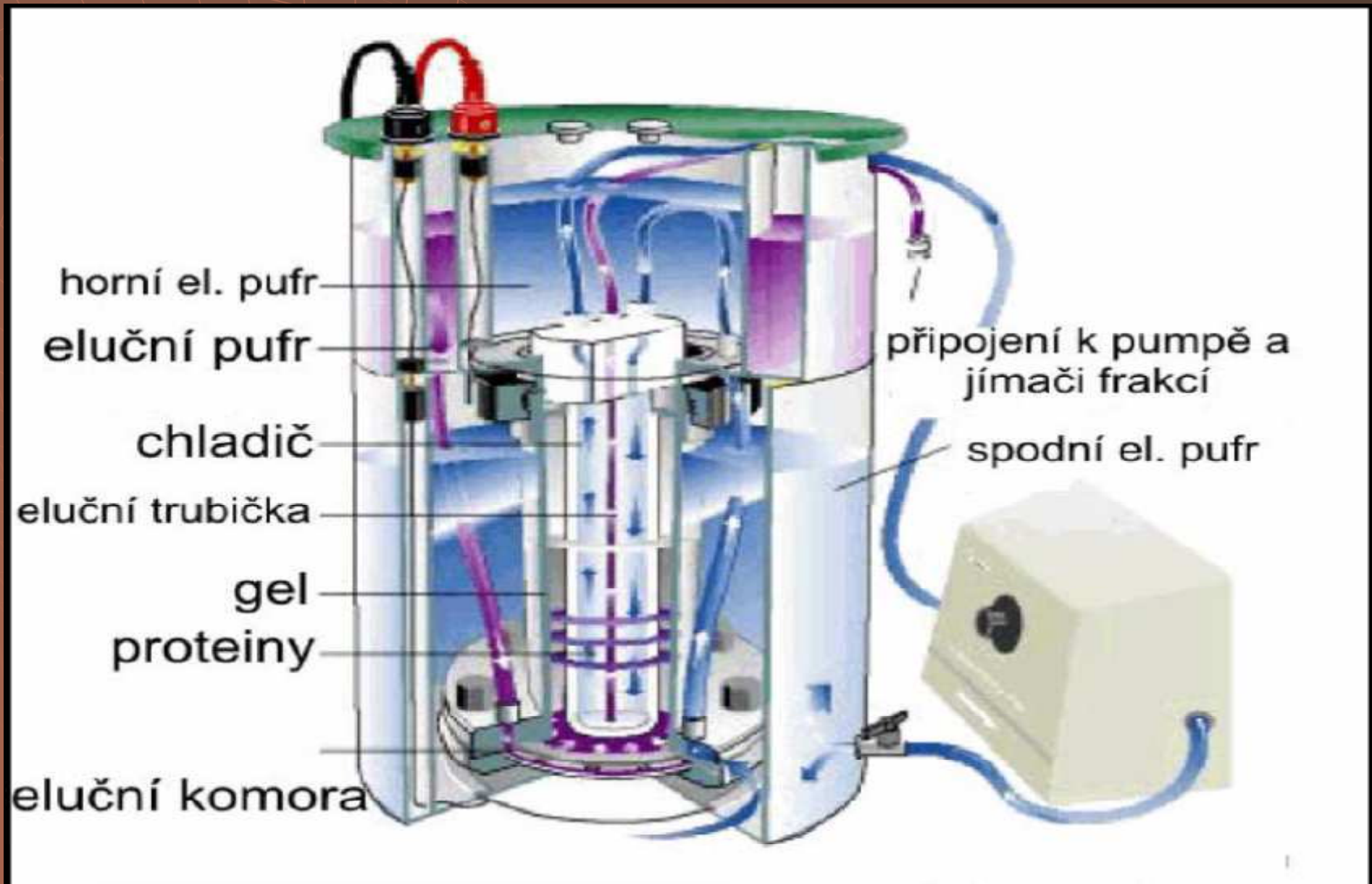

Automatizace PAGE Fast-system



Kapilární zónová elektroforéza

CZE

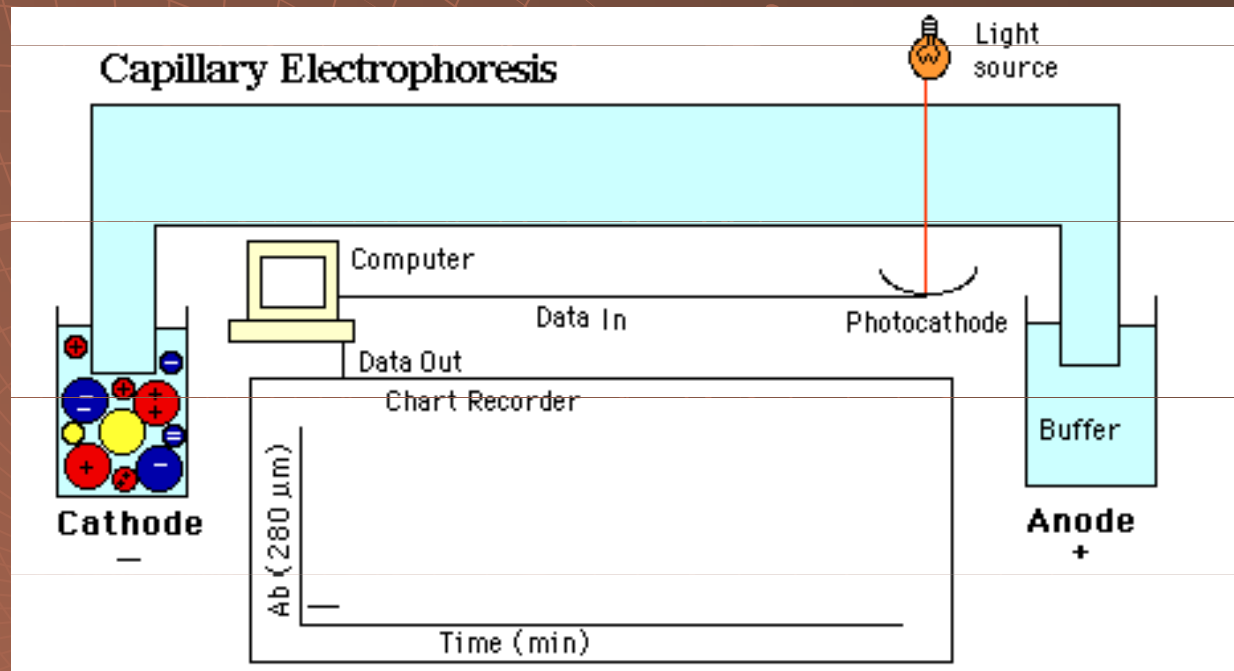

Hjerten 1967

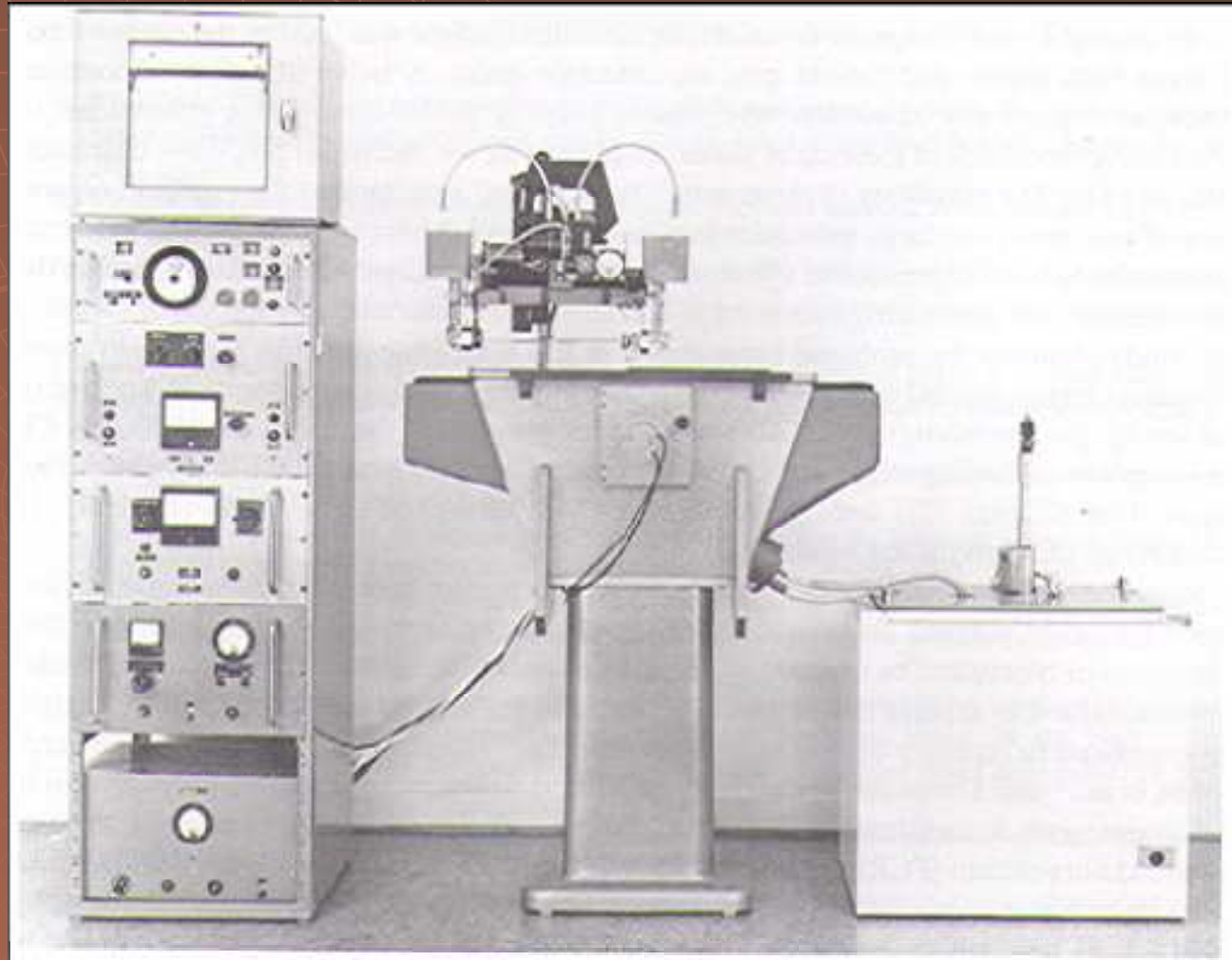

1981 - Jorgenson Lukacsová

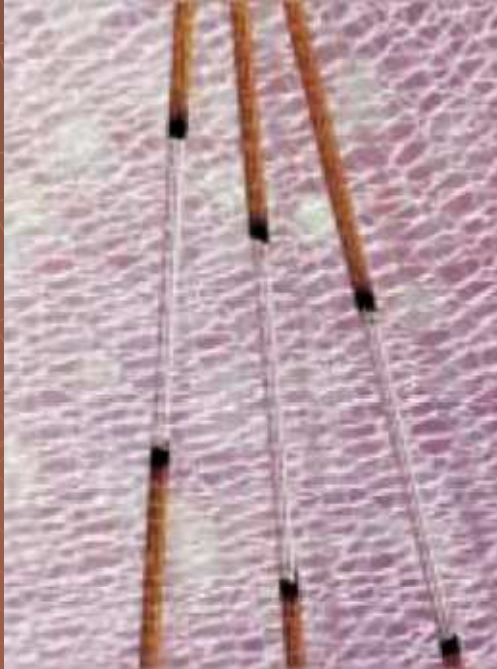

CLIN. CHEM. 27/9, 1551-1553 (1981)

Free-Zone Electrophoresis in Glass Capillaries

James W. Jorgenson and Kryn DeArman Lukacs

A simple theory of zone electrophoresis in open-tubular capillaries is developed. According to this theory, to achieve the highest resolution of zones, tubes with as small an inside diameter as possible should be used in combination with as high an applied voltage as feasible. To test this approach, we performed electrophoresis in glass capillaries with an internal diameter of $75\ \mu\text{m}$ and a length of 100 cm. A special fluorescence detector was used to detect fluorescent zones while they migrated inside the capillary. With the application of 30 kV potentials to this system, rapid and efficient separations of amino acids, peptides, and urinary amines were demonstrated. In all cases fluorescent derivatives were necessary for detection. Preliminary results are encouraging, and with further development of sensitive detection devices, applications in clinical analyses may be feasible.

small diameter simultaneously facilitates heat transfer as well as stabilizes the medium. Regardless of the diameter, some radial temperature gradient will persist. However, this temperature gradient is undesirable only to the extent that a significant fraction of the solute molecules making up a zone spend longer than average times migrating within "cool" or "hot" regions of the tube radius. Here a more subtle effect of reduced tube diameters comes into play. If the diameter is small enough that solute molecules diffuse back and forth across the tube many times during their migration, then the probability that a significant fraction of molecules will spend excessive amounts of time in any one portion of the tube radius is greatly reduced. Thus the solute molecules have an excellent chance of traveling throughout all portions of the tube radius, and any variations in migration velocity will tend to average out.

To summarize, the possible advantages of performing zone electrophoresis in open tubes of small diameter are:

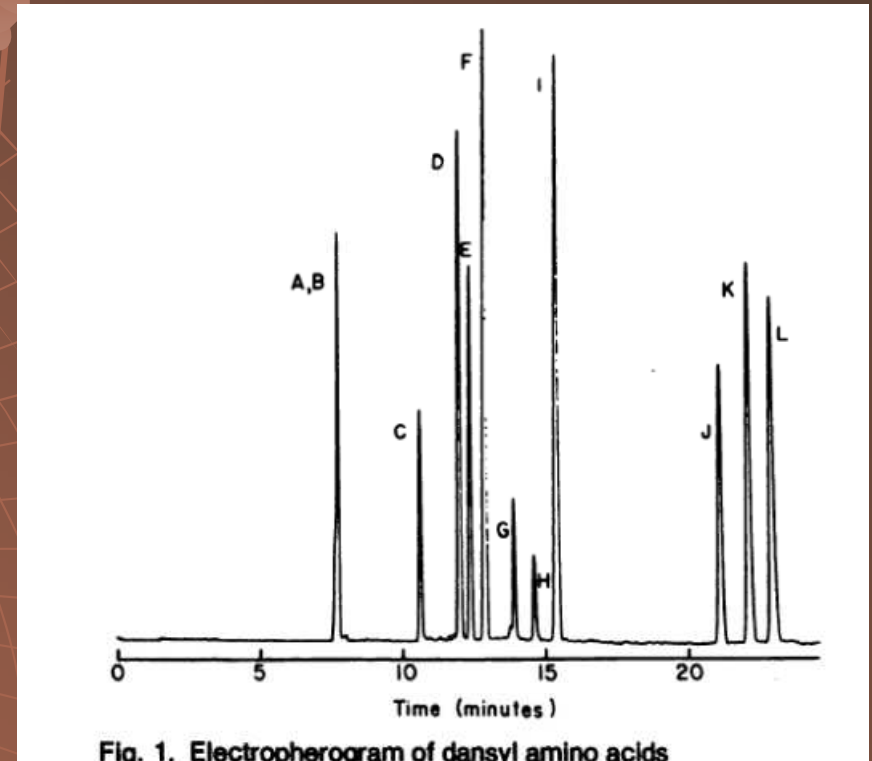
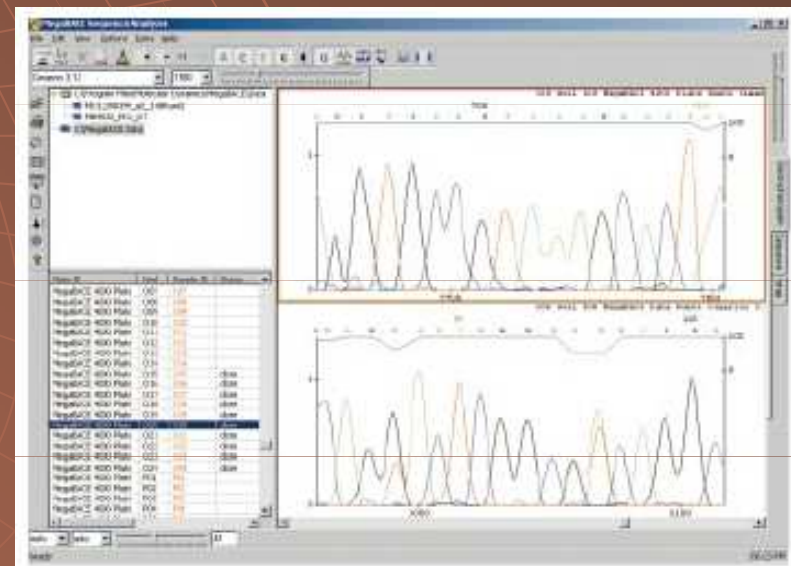
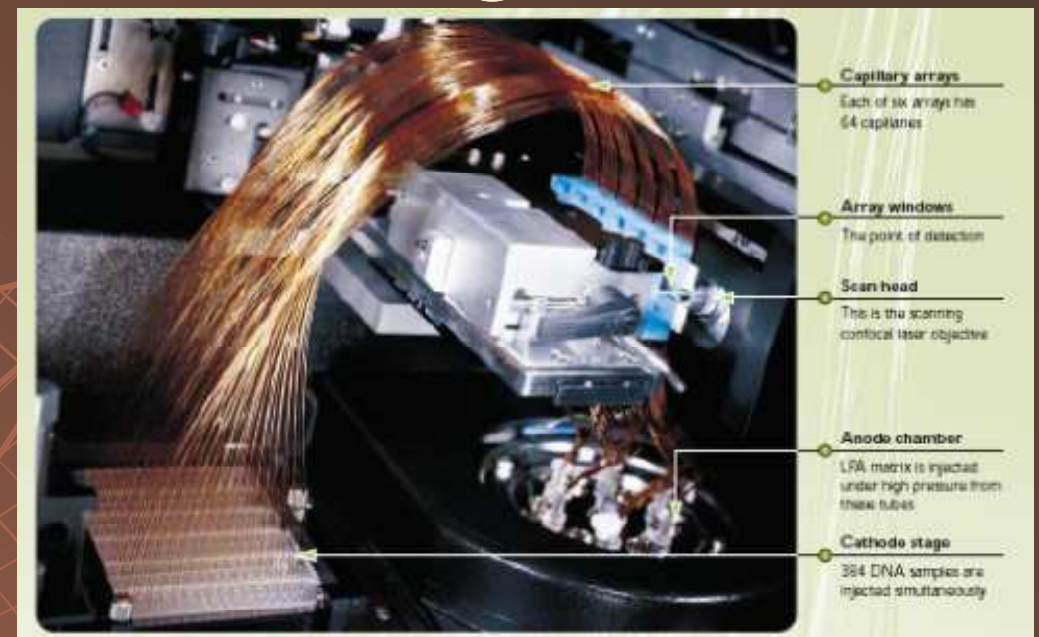

Fig. 1. Electropherogram of dansyl amino acids

Beckman 1987



2003 - Projekt lidského genomu





Proč CE a biochemie ?

Výhody CE

- ◆ **Aplikační diverzita**

nabité i neutrální látky

nízkomolekulární i vysokomolekulární látky

chirální i achirální látky

bakterie i viry

Výhody CE

- ◆ Aplikací diverzita
- ◆ Jednoduchá instrumentace

Výhody CE

- ◆ Aplikační diverzita
- ◆ Jednoduchá instrumentace

CZE, MEKC,
CIEF, CITP
NACE, MEEKC,
CGE, ChCE



CEC

Výhody CE

- ◆ Aplikační diverzita
- ◆ Jednoduchá instrumentace
- ◆ Vysoké rozlišení a účinnost separací
- ◆ Malá spotřeba vzorku
- ◆ Rychlost analýzy
- ◆ Malá spotřeba chemikálií a malé množství odpadů

Módy CZE

Use CE Mode...	For Analysis of...
Capillary zone electrophoresis (CZE)	Ions, etc.
Micellar electrokinetic chromatography (MEKC)	Neutral and ionic analytes
Chiral capillary electrophoresis (CCE)	Chiral molecules
Capillary electrochromatography (CEC)	Small molecules
Capillary gel electrophoresis (CGE/SDS-PAGE)	DNA/RNA size/protein MW
Capillary isoelectric focussing (CIEF)	Protein/peptide isoelectric point
Capillary isotachopheresis (CITP)	Ions

Kapilární zónová elektroforéza ve volné kapiláře

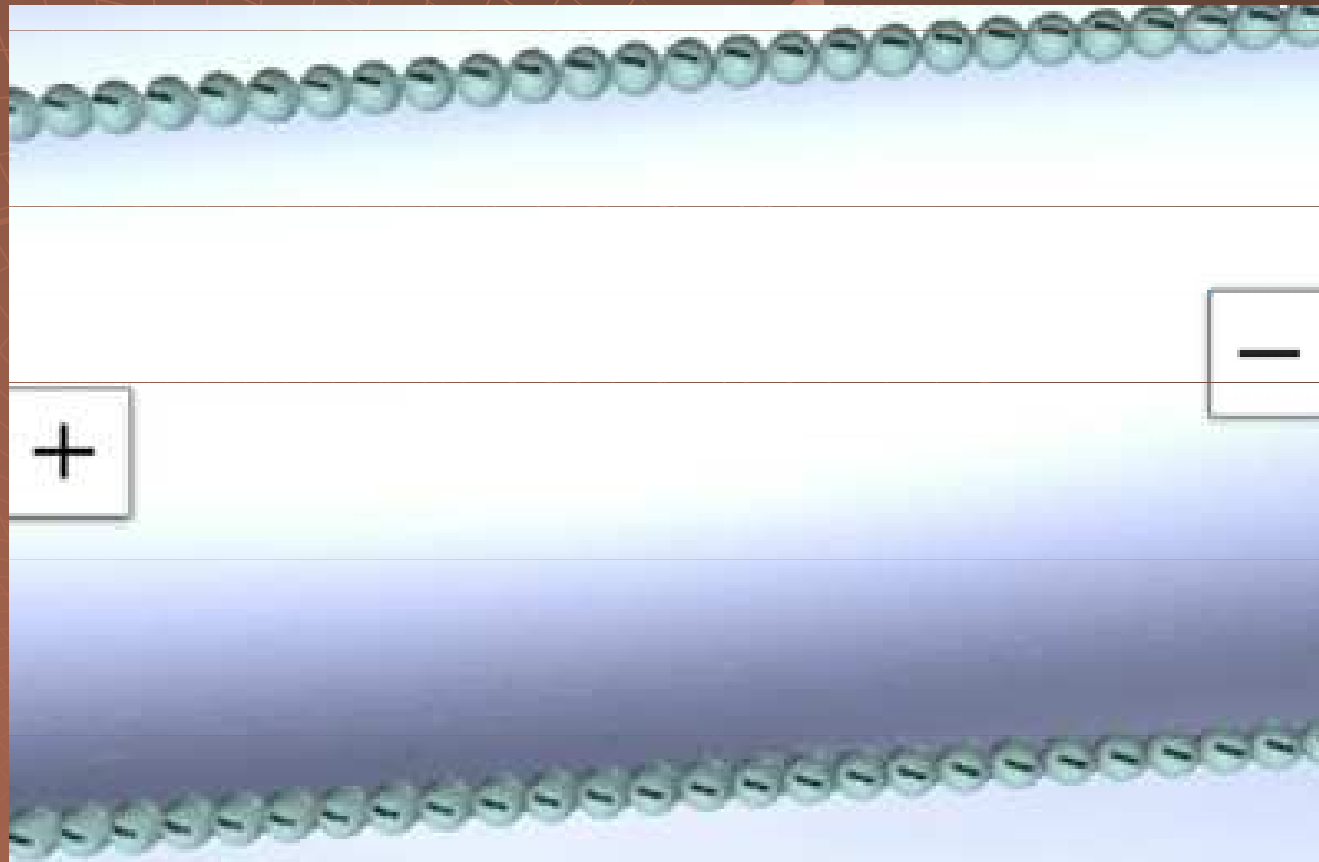

Výsledná mobilita částic při CZE

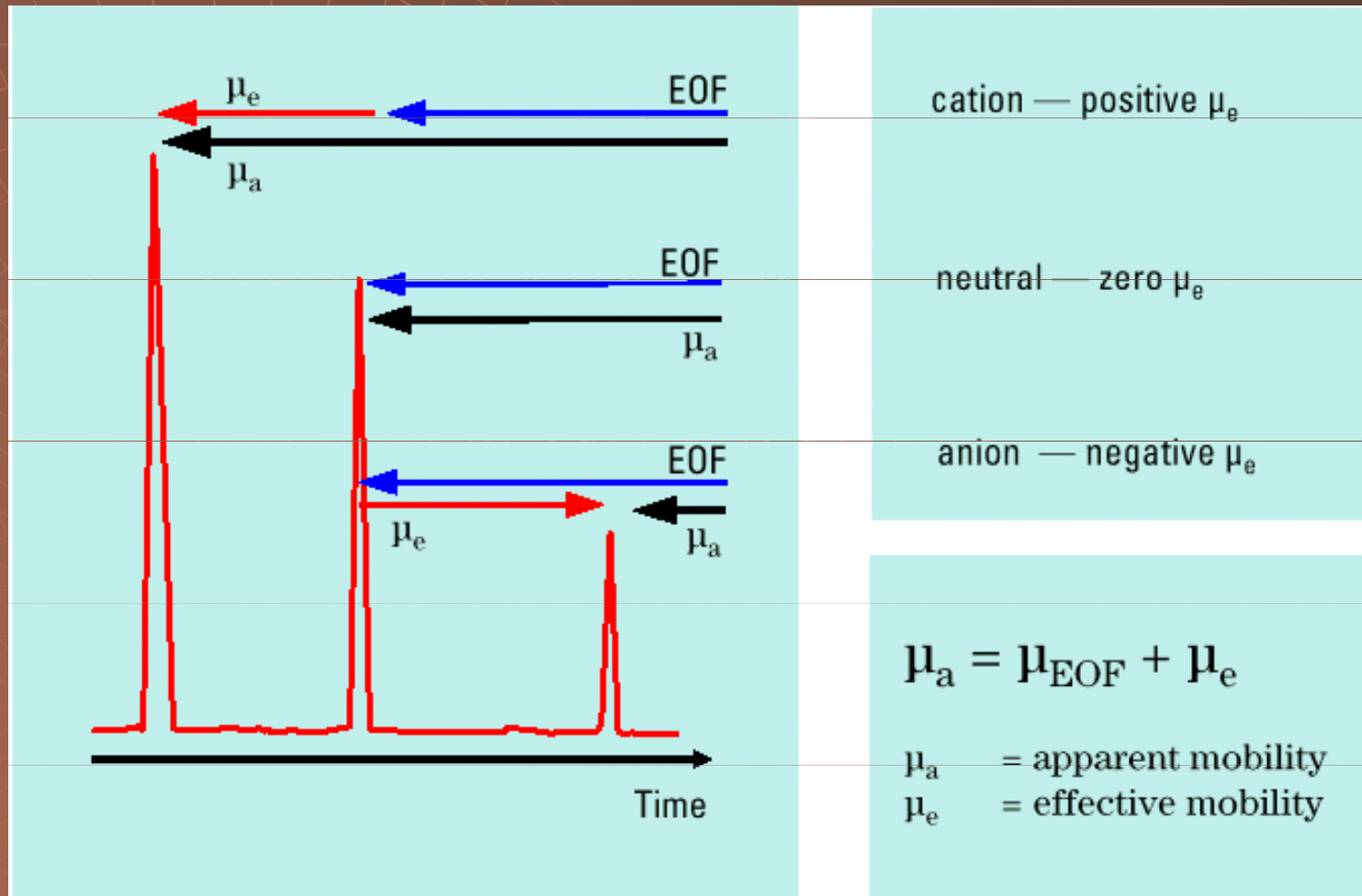

Separace aniontů pomocí CZE

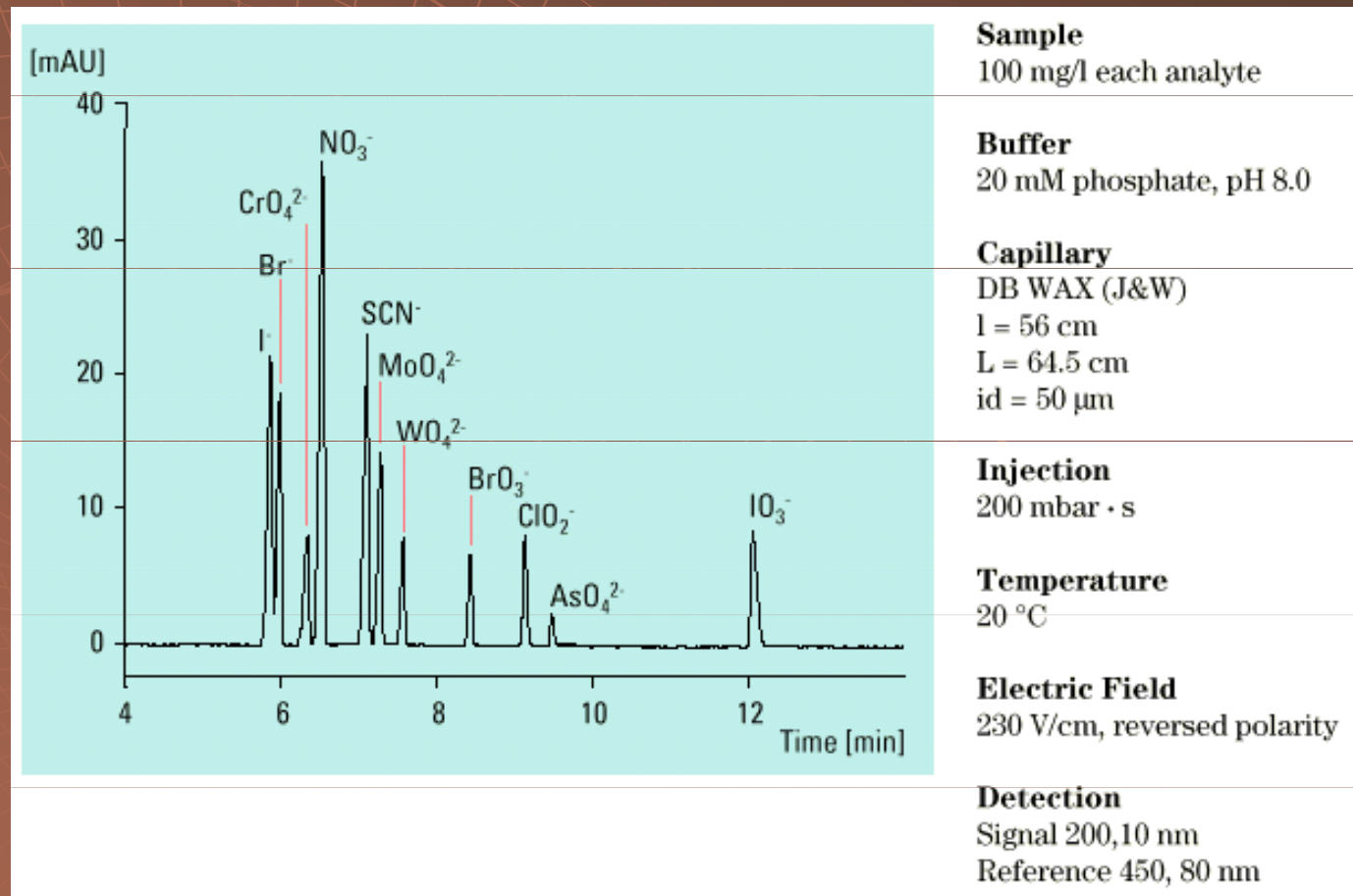

Stanovení aktivity HD pomocí CZE

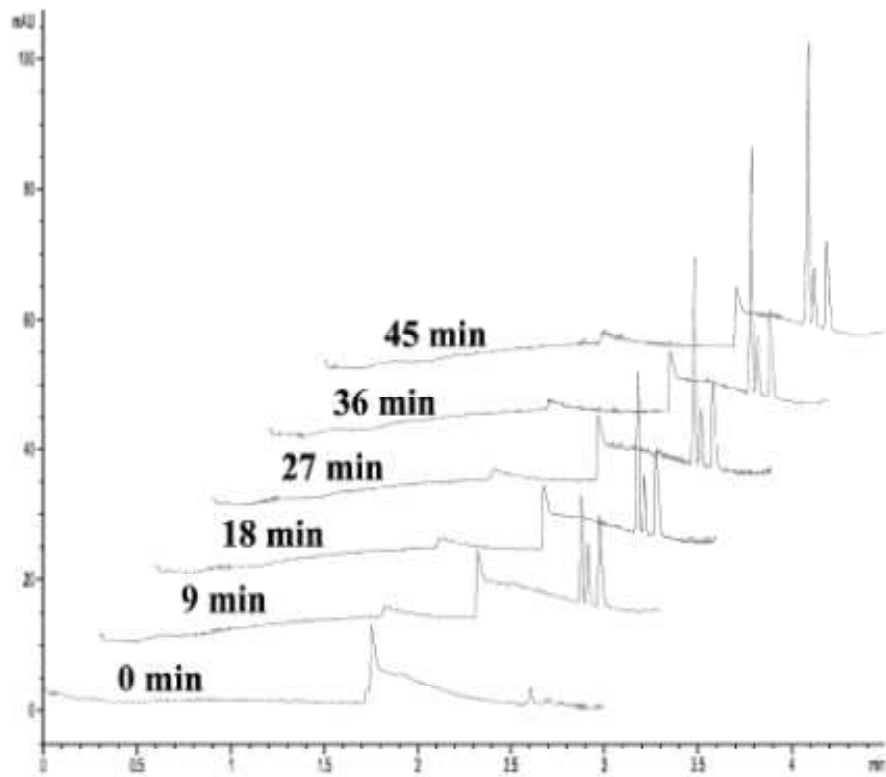

Fig. 1. CZE analysis of haloalkane dehalogenase catalysed reaction using indirect detection. Overlaid electropherograms show the reaction mixture of 10 mM 1,3-dibromopropane in 50 mM glycine buffer (pH 9.0) at 30°C before and 9, 18, 27, 36 and 45 min after addition of 10 μ l of enzyme solution. The separation conditions are the same as in Table 1.

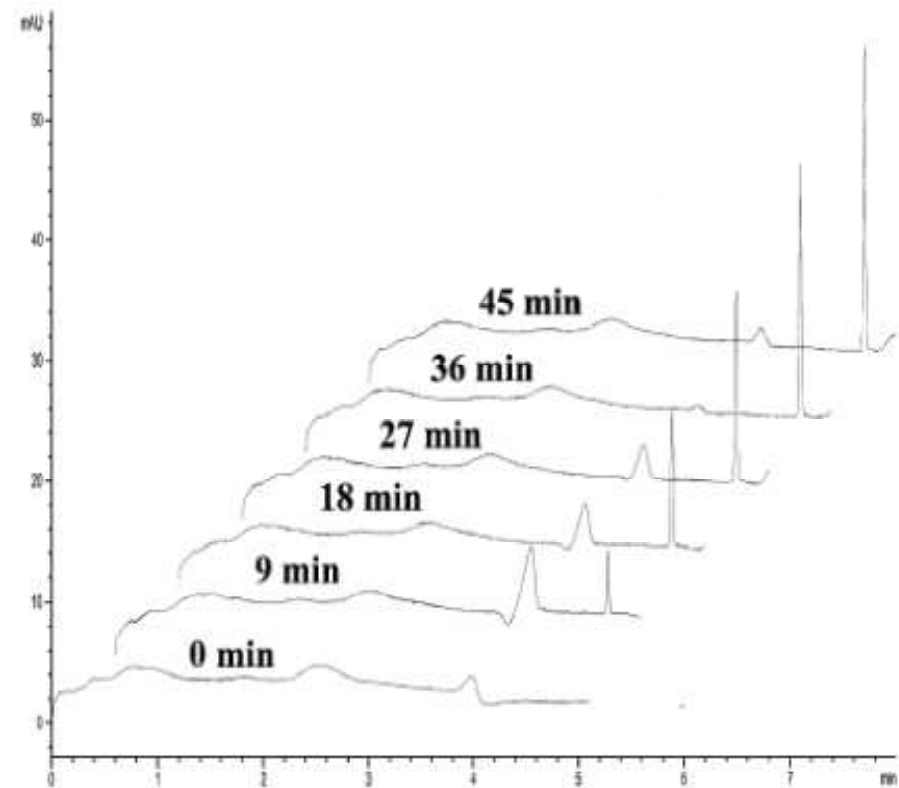
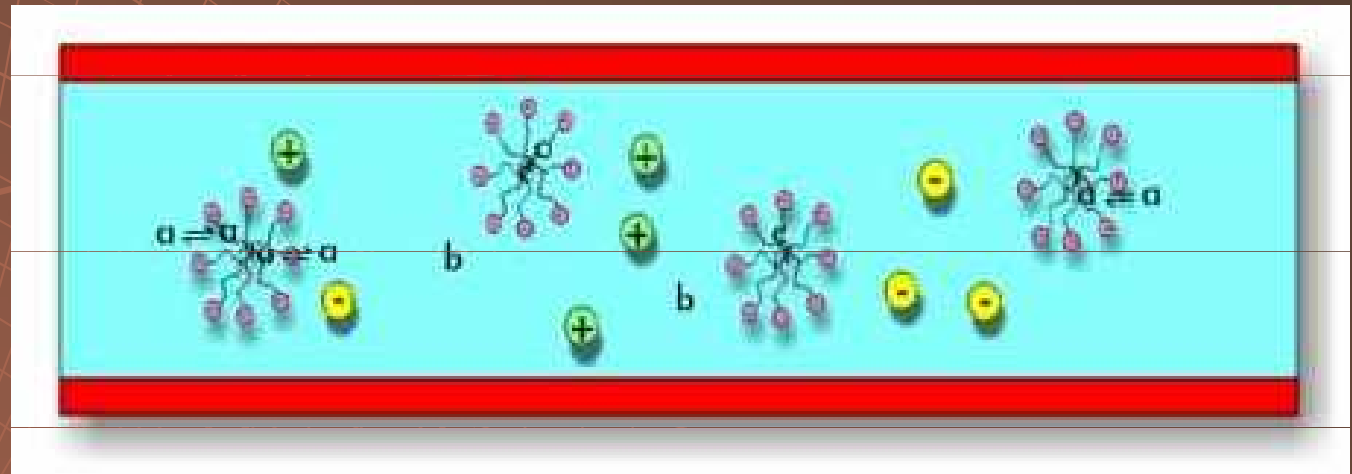
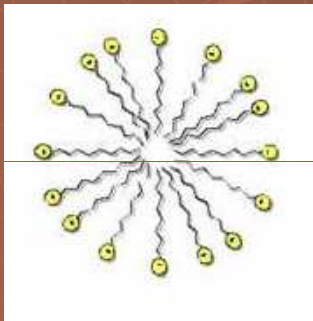

Fig. 2. CZE analysis of haloalkane dehalogenase catalysed reaction using long-end injection in combination with direct detection. The enzyme preparation was 4 times diluted with 50 mM phosphate buffer (pH 7.5). Separation conditions are the same as in Table 2. The other conditions are the same as in Fig. 1.

Princip MEKC

Micela



a – střed – rozpustná v obou

b – silně hydrofilní – nerozpustná v
micelle

c – silně hydrofóbní – nerozpustná ve
vodné fázi

Micelární elektrokinetická chromatografie

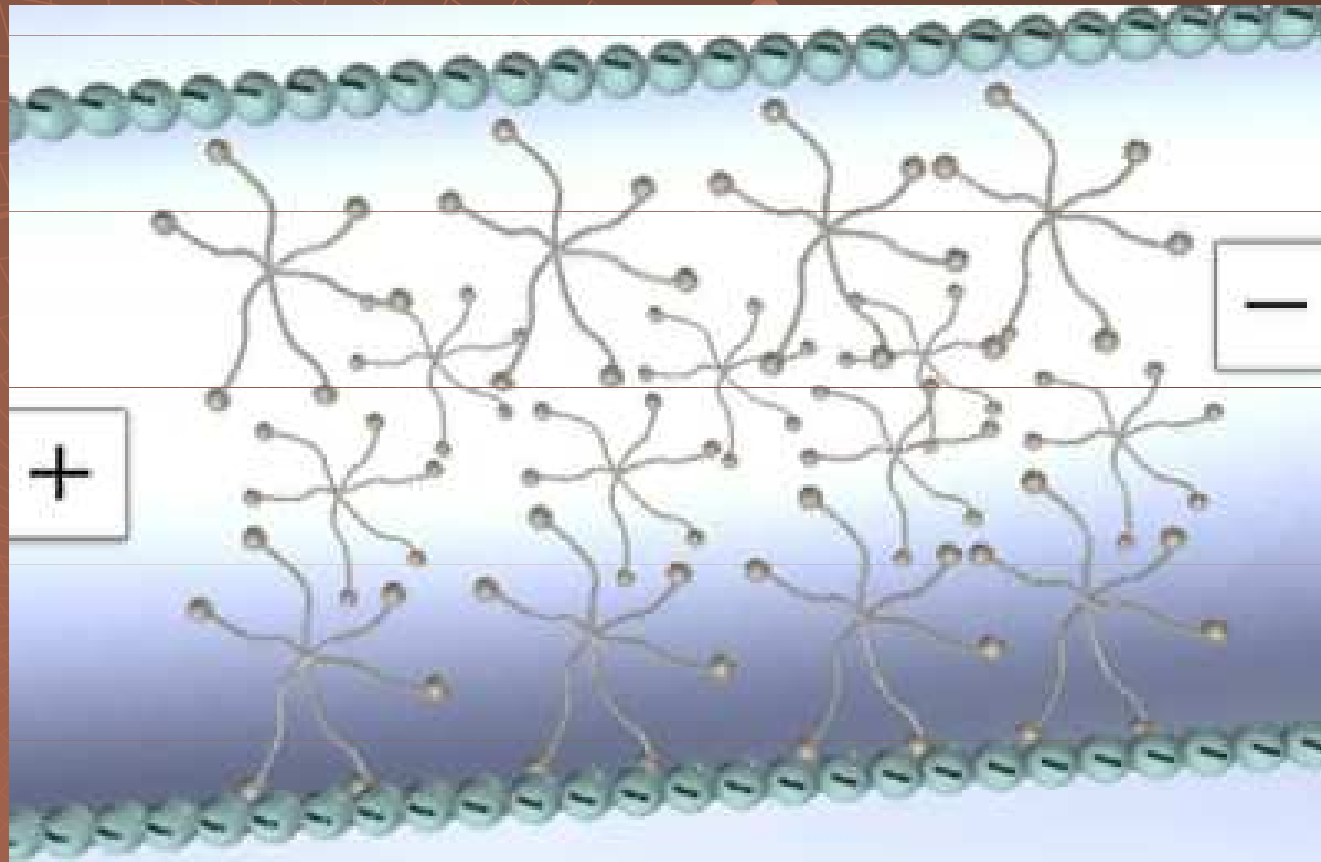

Separace fenolů a alkoholů pomocí MEKC

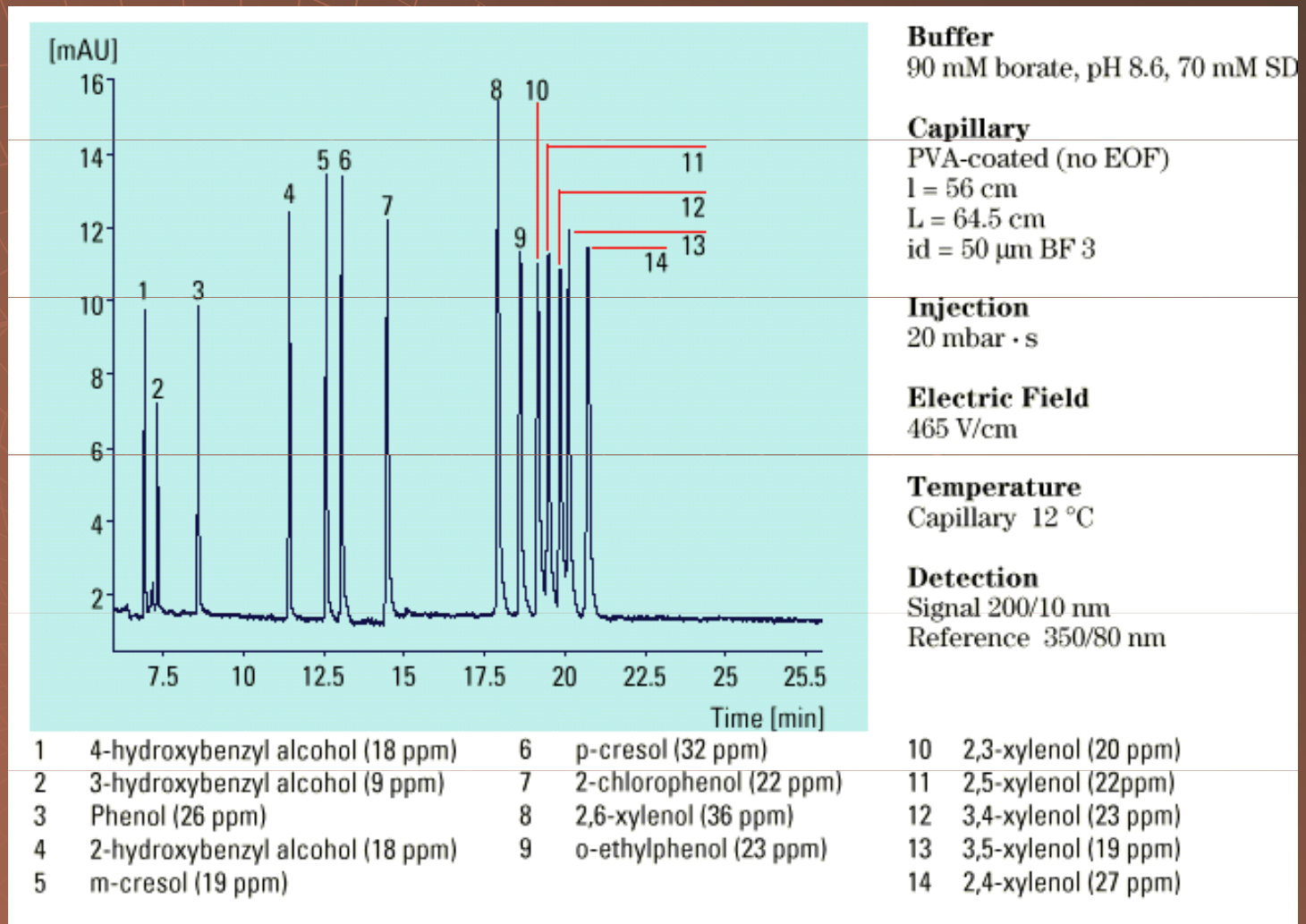

Stanovení aktivity CYP 2C9 pomocí MEKC

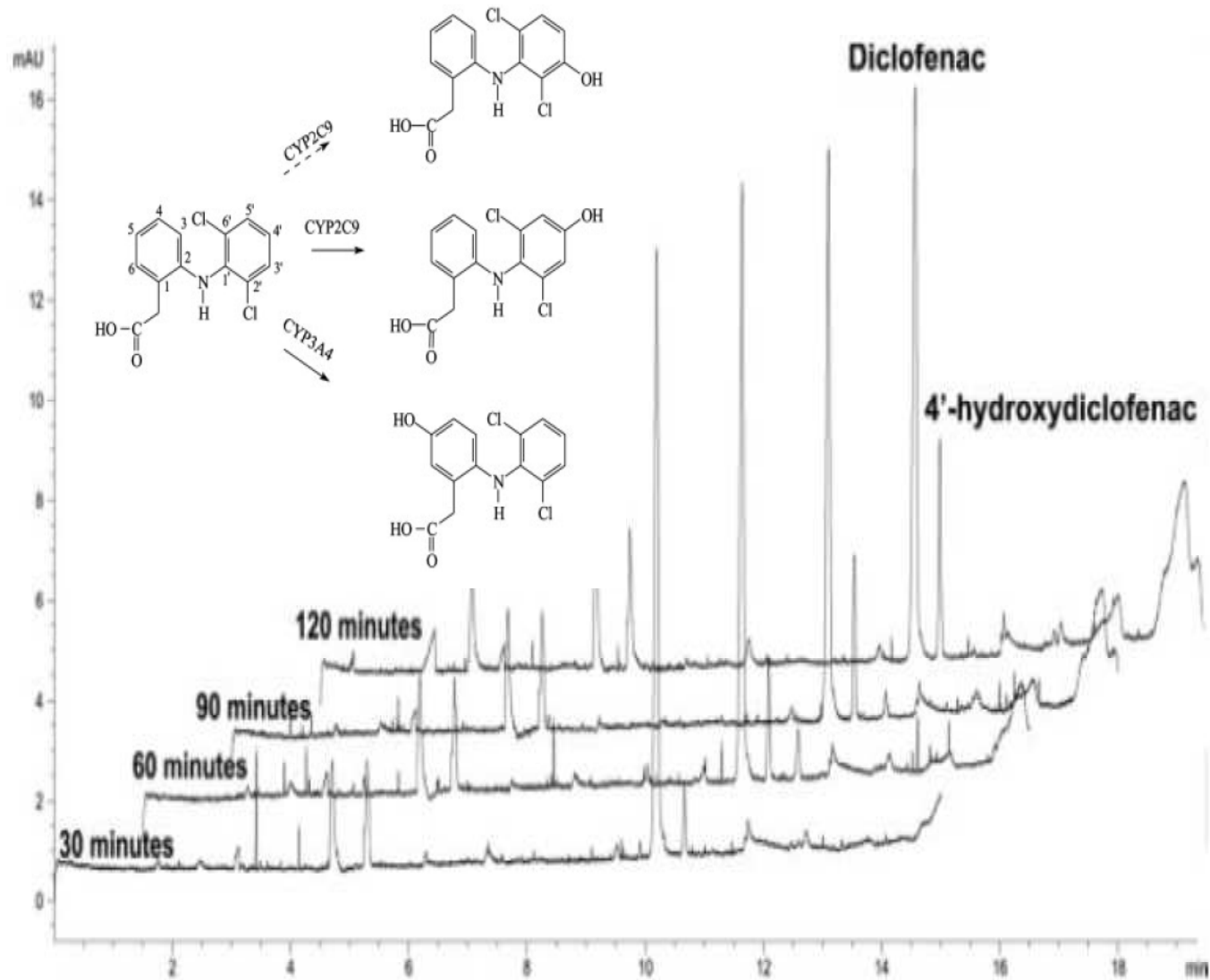
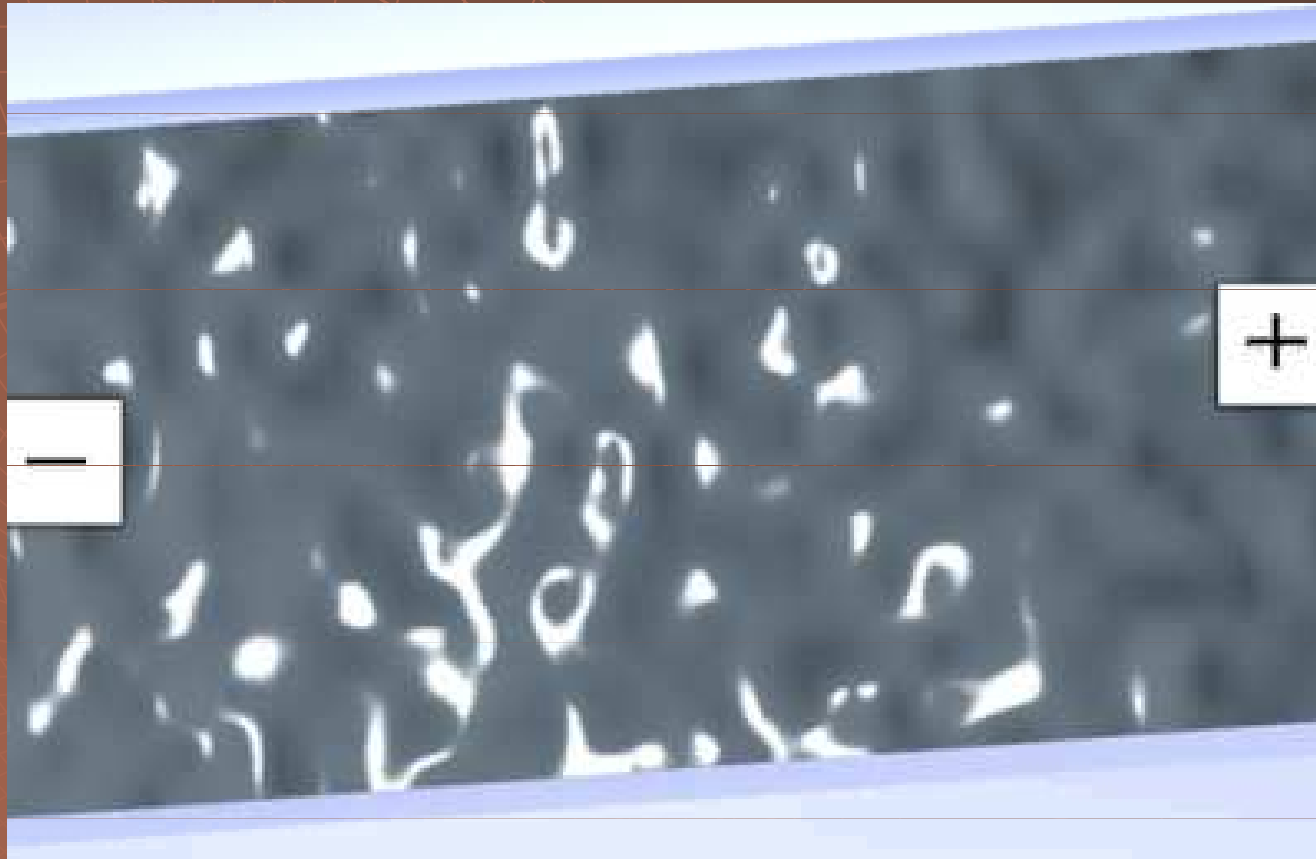
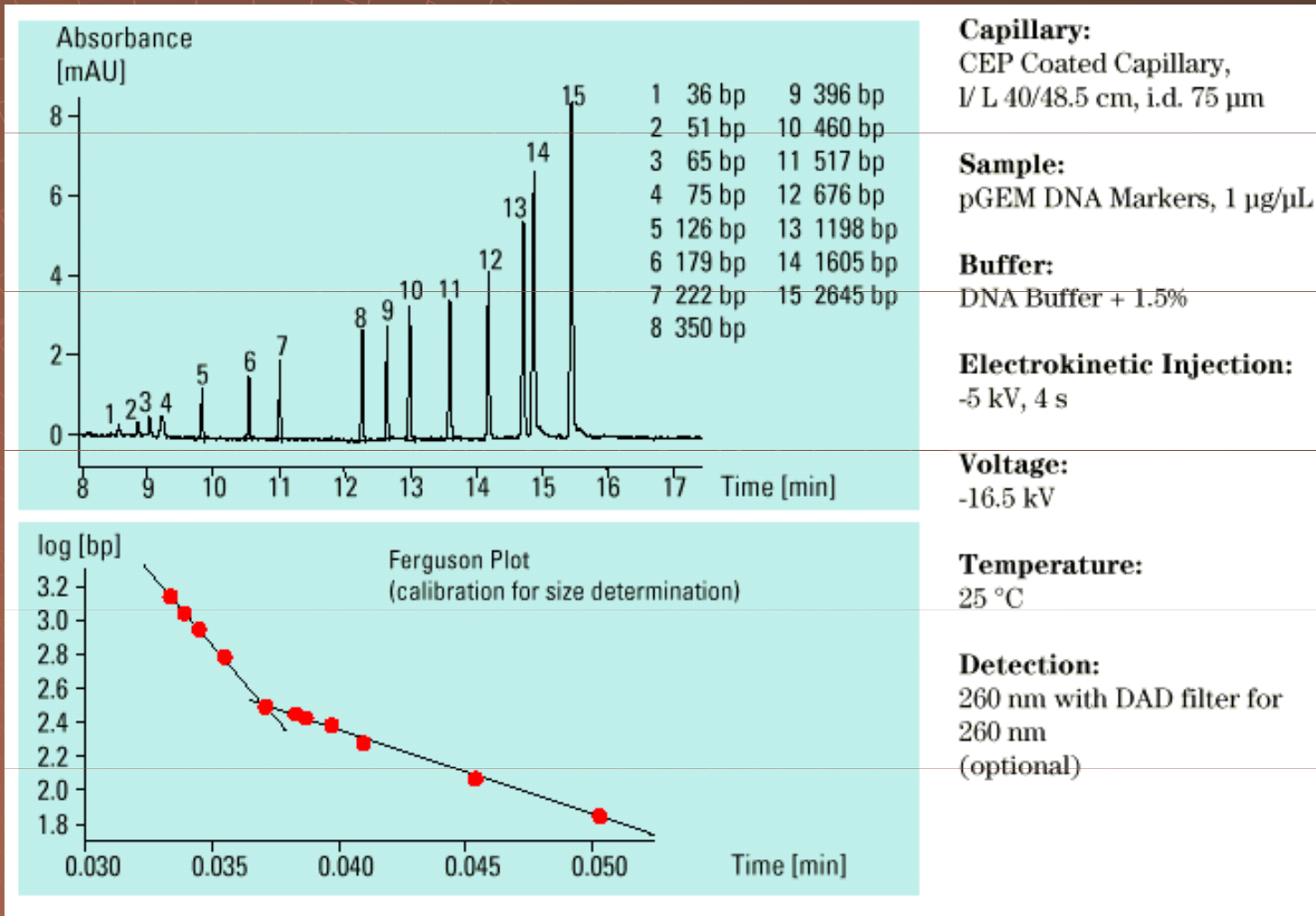

Figure 3. MEKC analysis of CYP2C9 reaction. Overlaid electropherograms show the enzymatic reaction under standard conditions as described in Section 2; the final concentrations of CYP2C9 and diclofenac in reaction mixture were 9.7 nM and 100 μ M, respectively. MEKC conditions as in Fig. 2.

Kapilární gelová elektroforéza



CGE fragmentů dsDNA





Instrumentace CZE

Schéma zařízení pro CZE

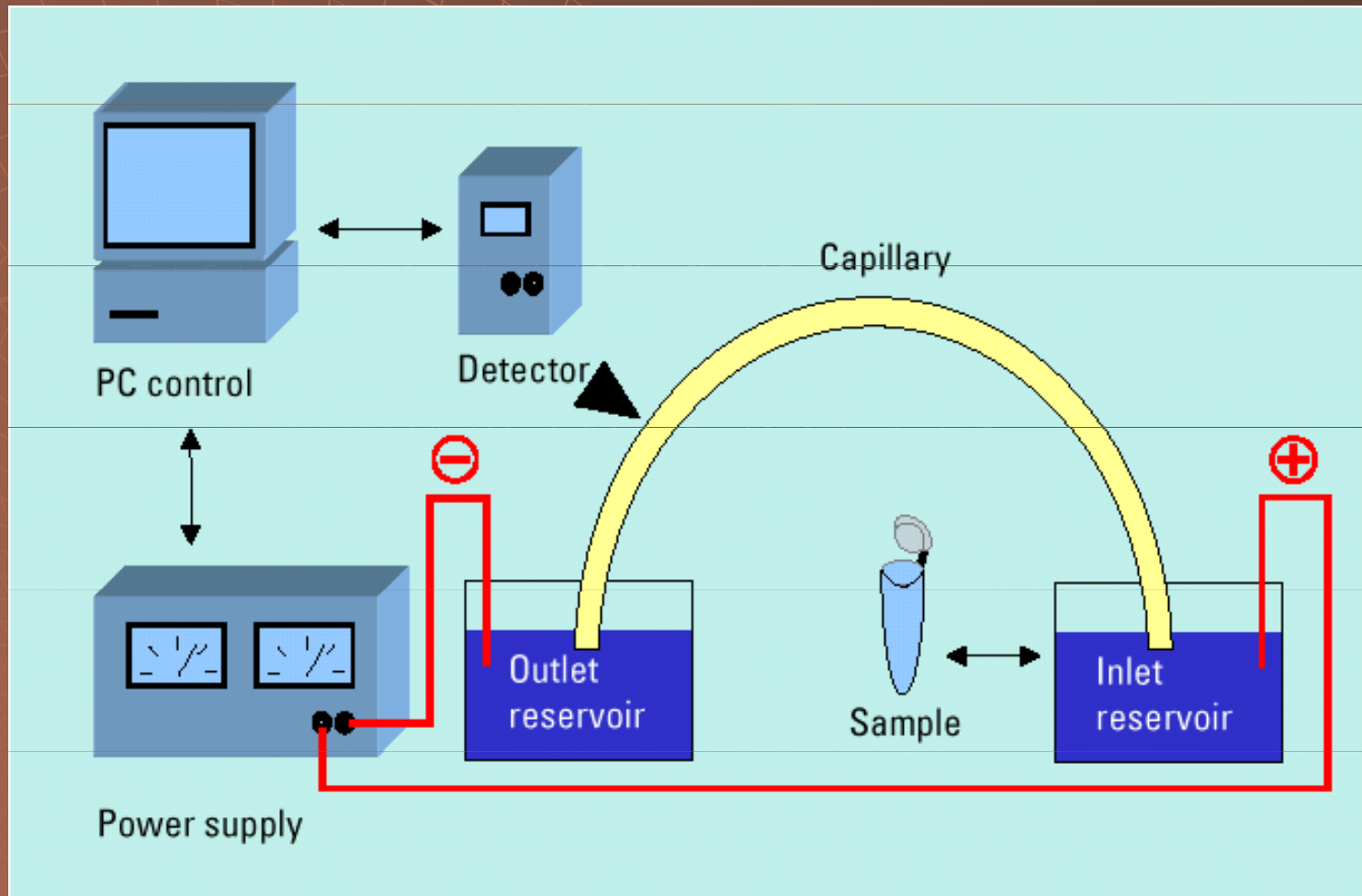

Napájecí zdroj

- ◆ stabilizovaný ± 30 kV
300 μ A
- ◆ konstantní napětí nebo proud
- ◆ obojí polarita
- ◆ ochrana obsluhy

Kapilára

- ◆ křemenná - 25 - 100 μm i.d
- 350 μm o.d.
- ◆ délka až 100 cm délka
- ◆ polyimidové vnější pokrytí

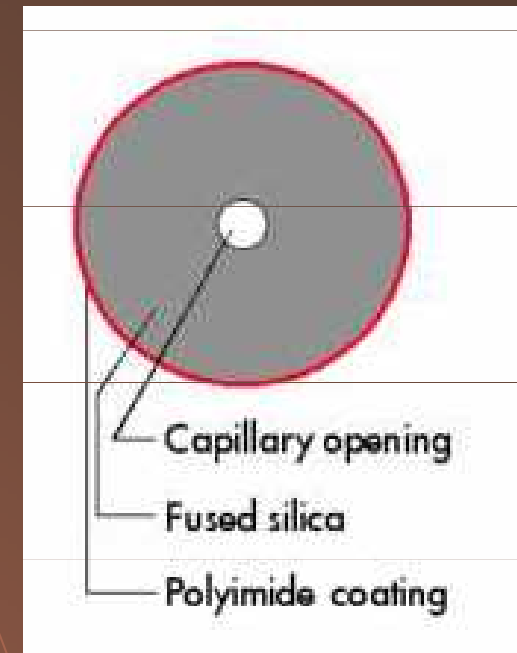

Dávkování - hydrodynamické

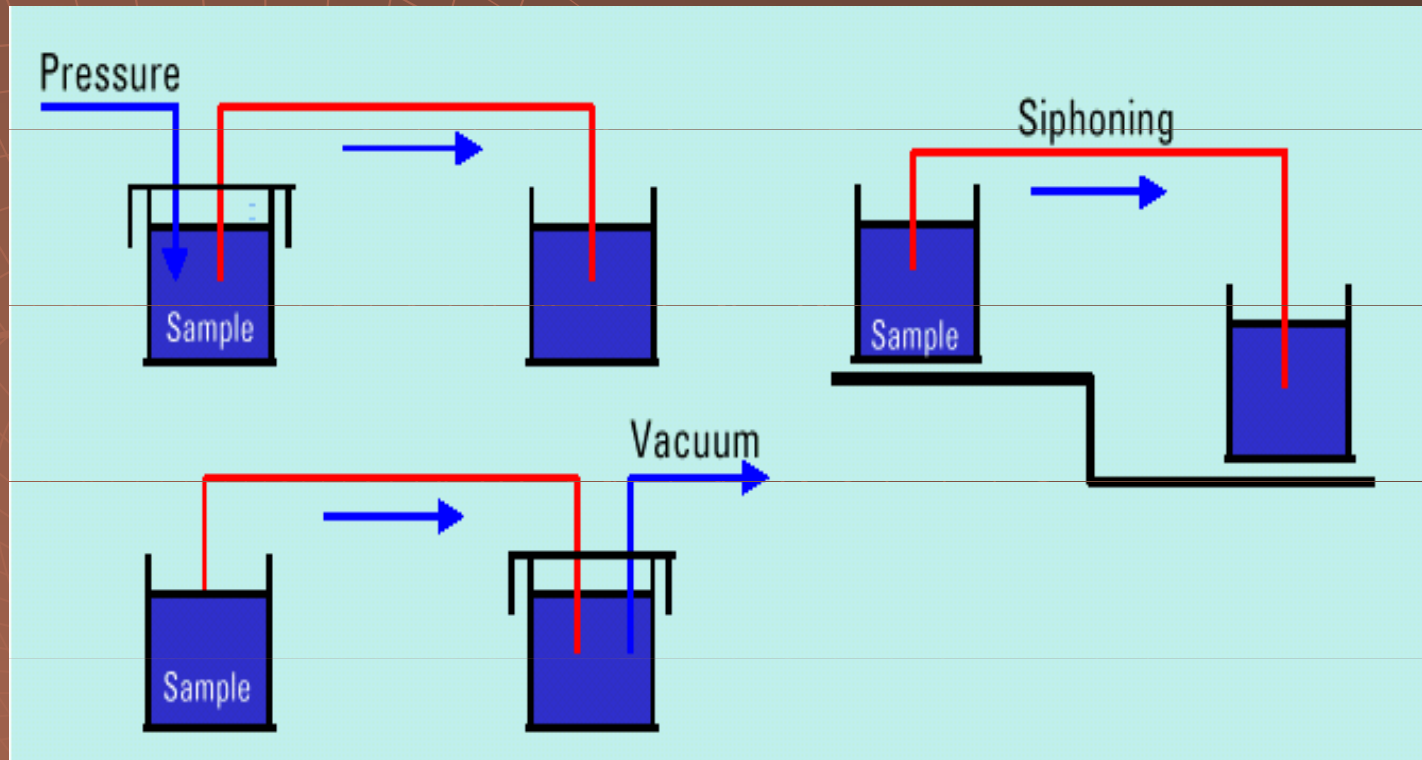

Dávkování - elektrokinetické

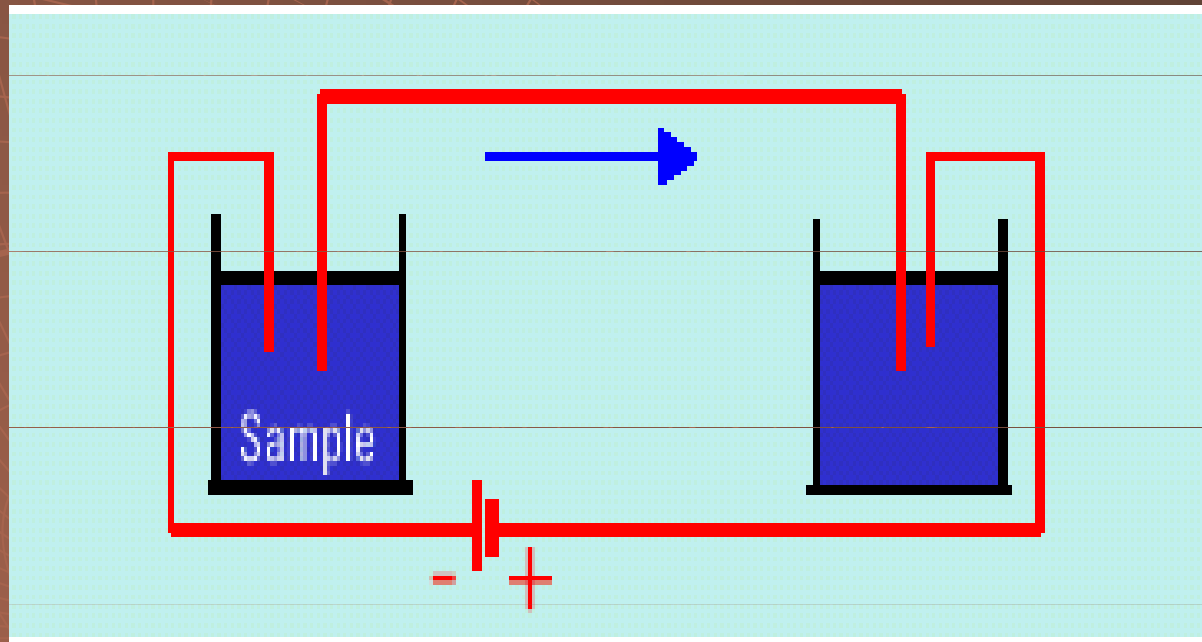

Detekce spektrofotometrická

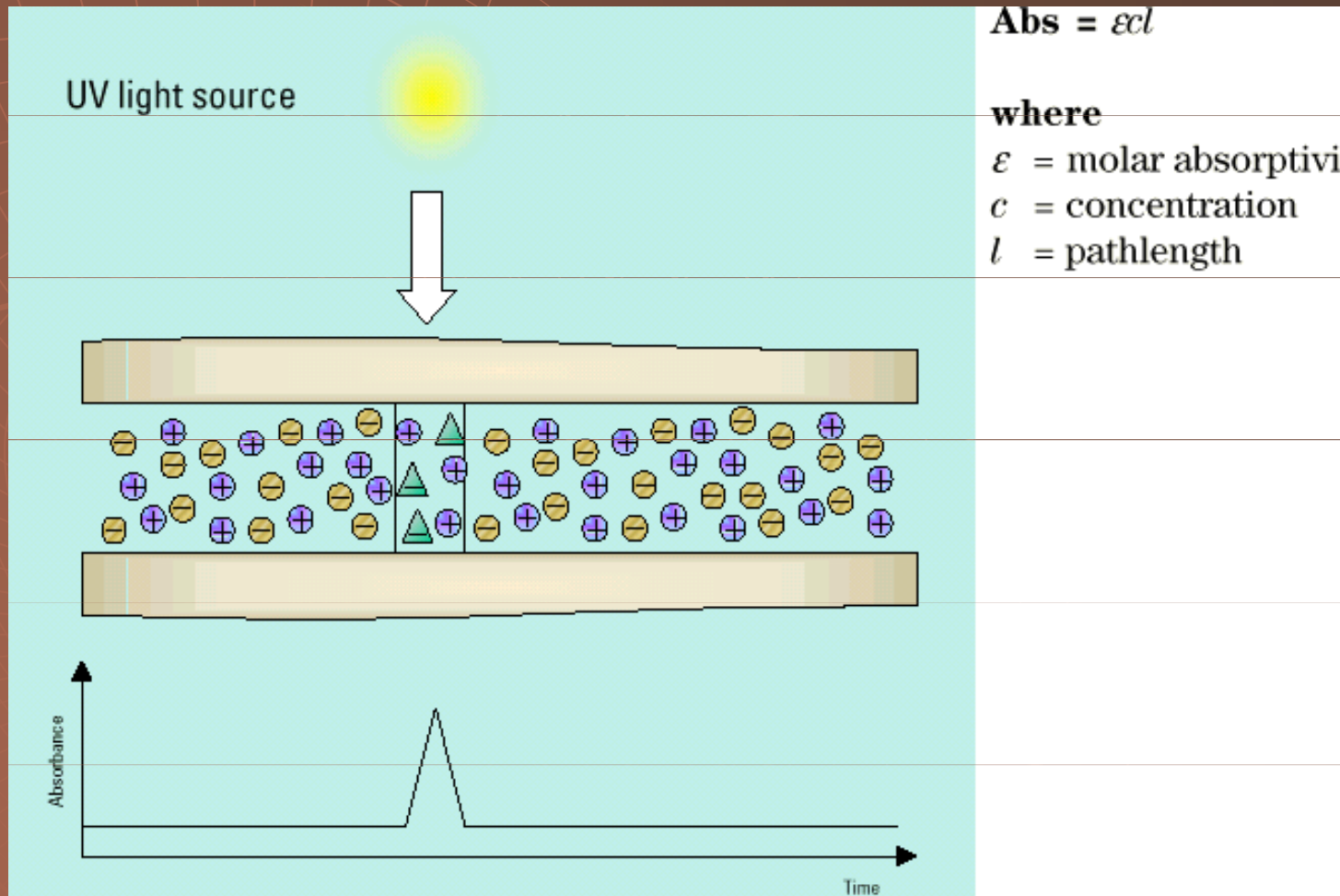

Detekce fluorescenční

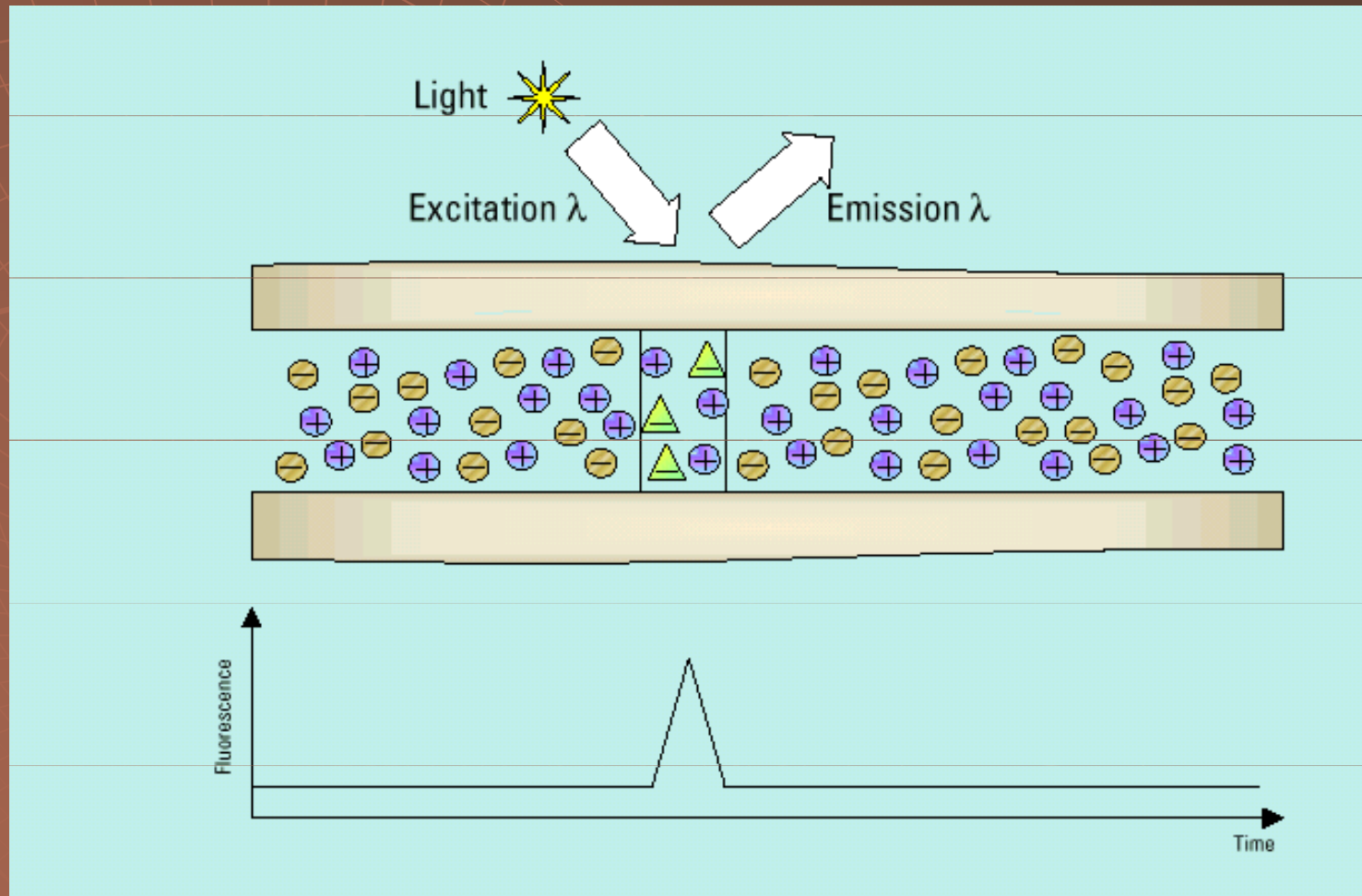

2003 - Projekt lidského genomu



2003 - Projekt lidského genomu

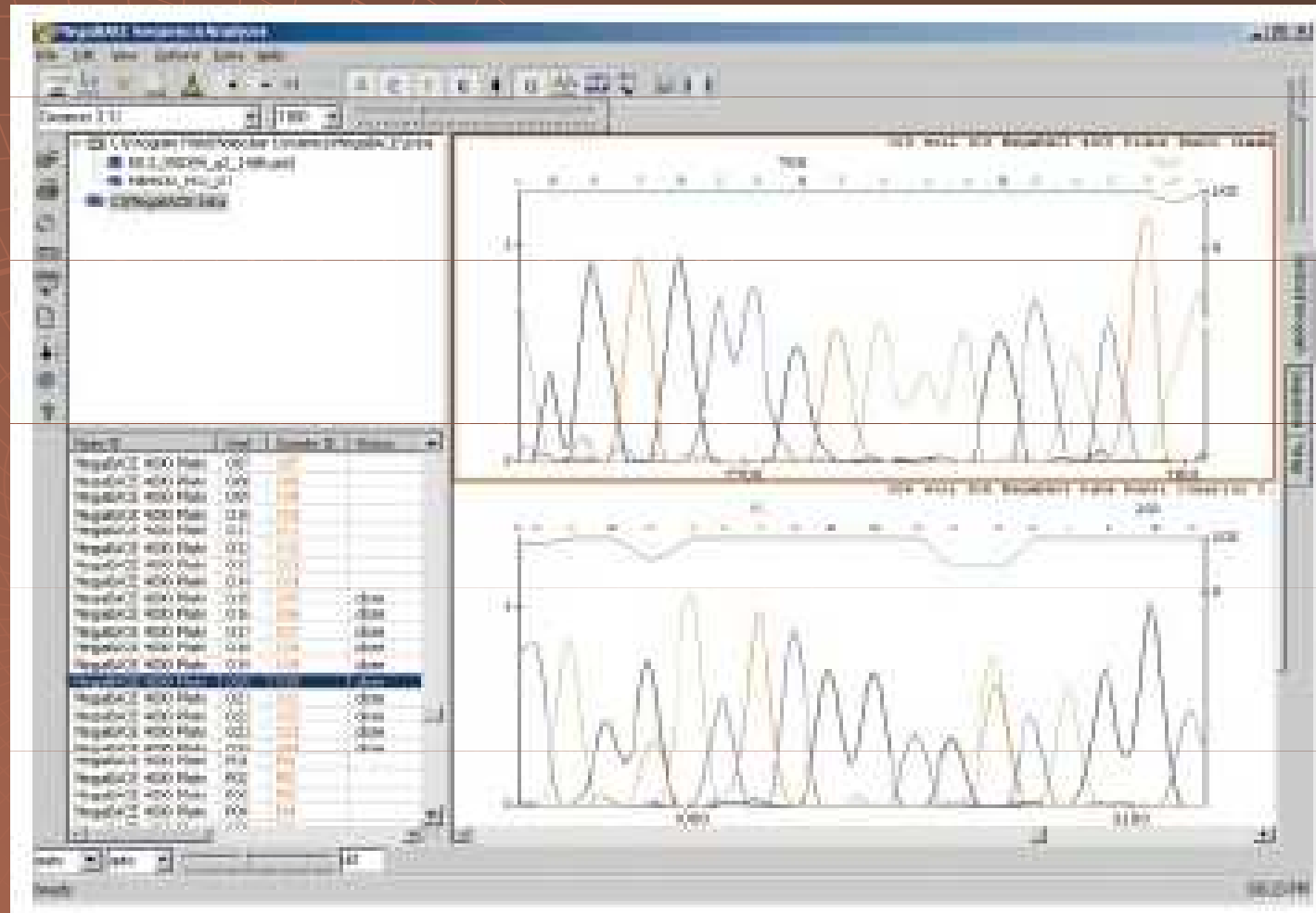

3730xl DNA Analyzer Applied Biosystems



1997 μ CE

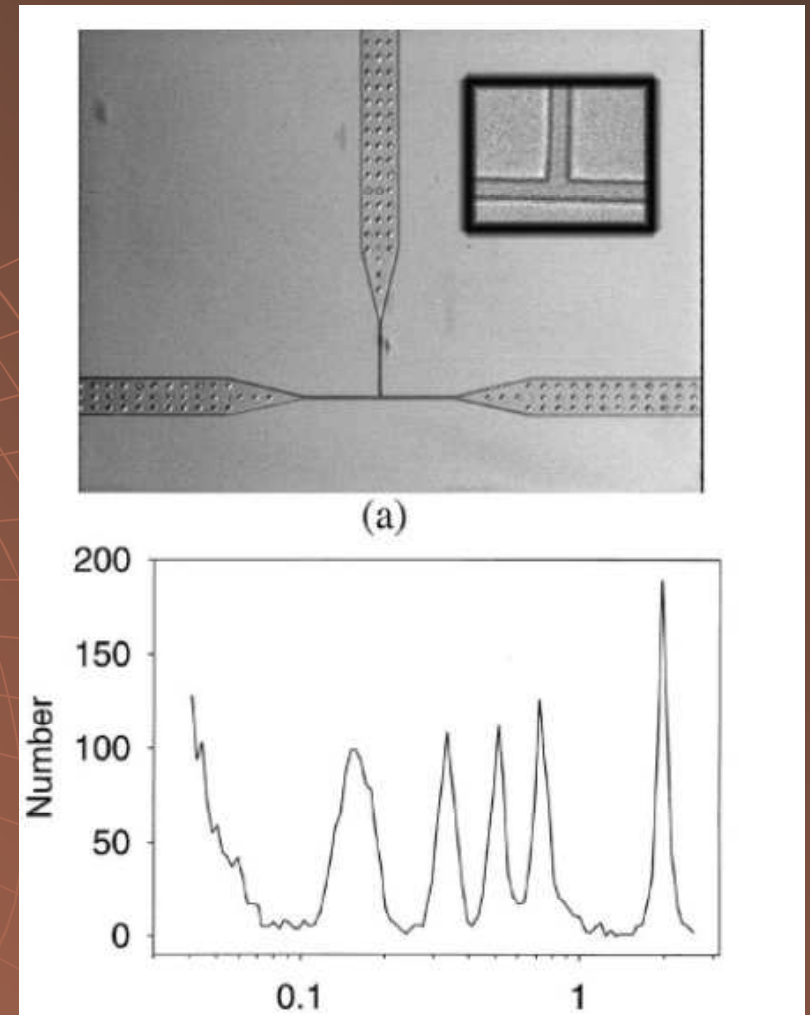
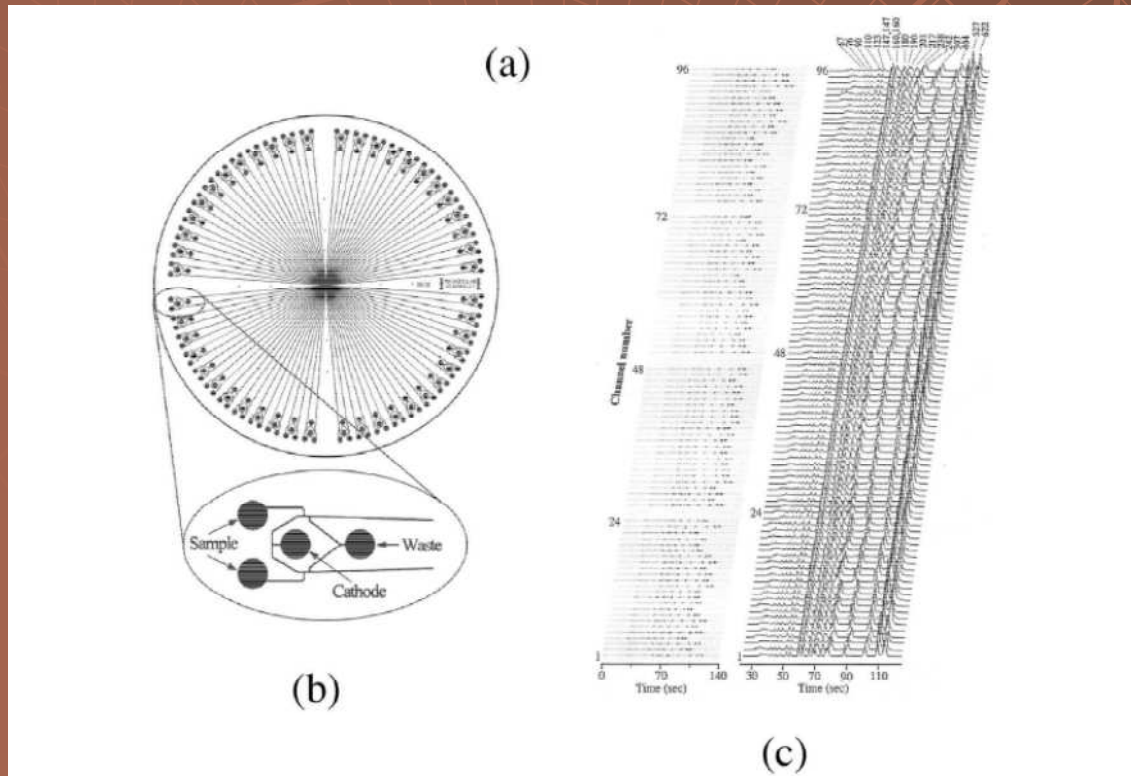

Klasická CZE

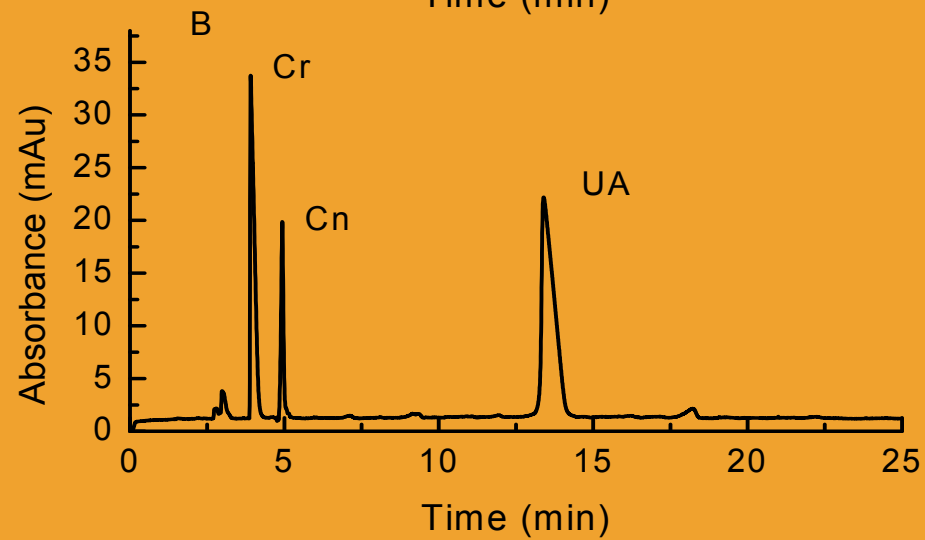
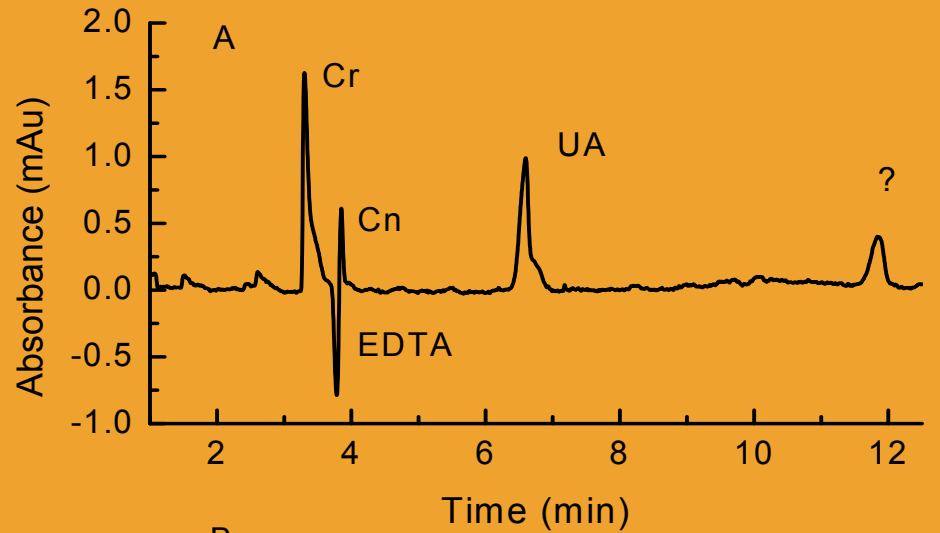

Microchip CZE

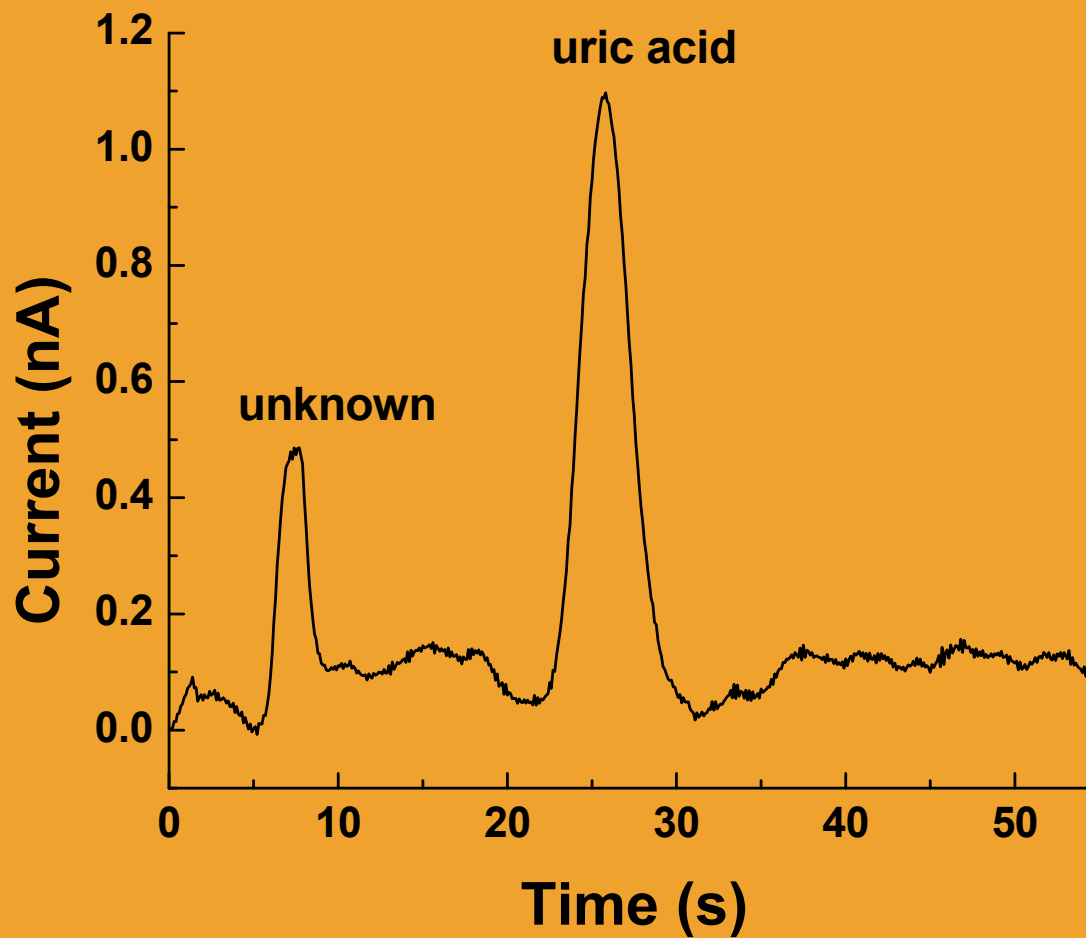

Bioanalyser Agilent 210₀



Bioanalyser Agilent 210₀

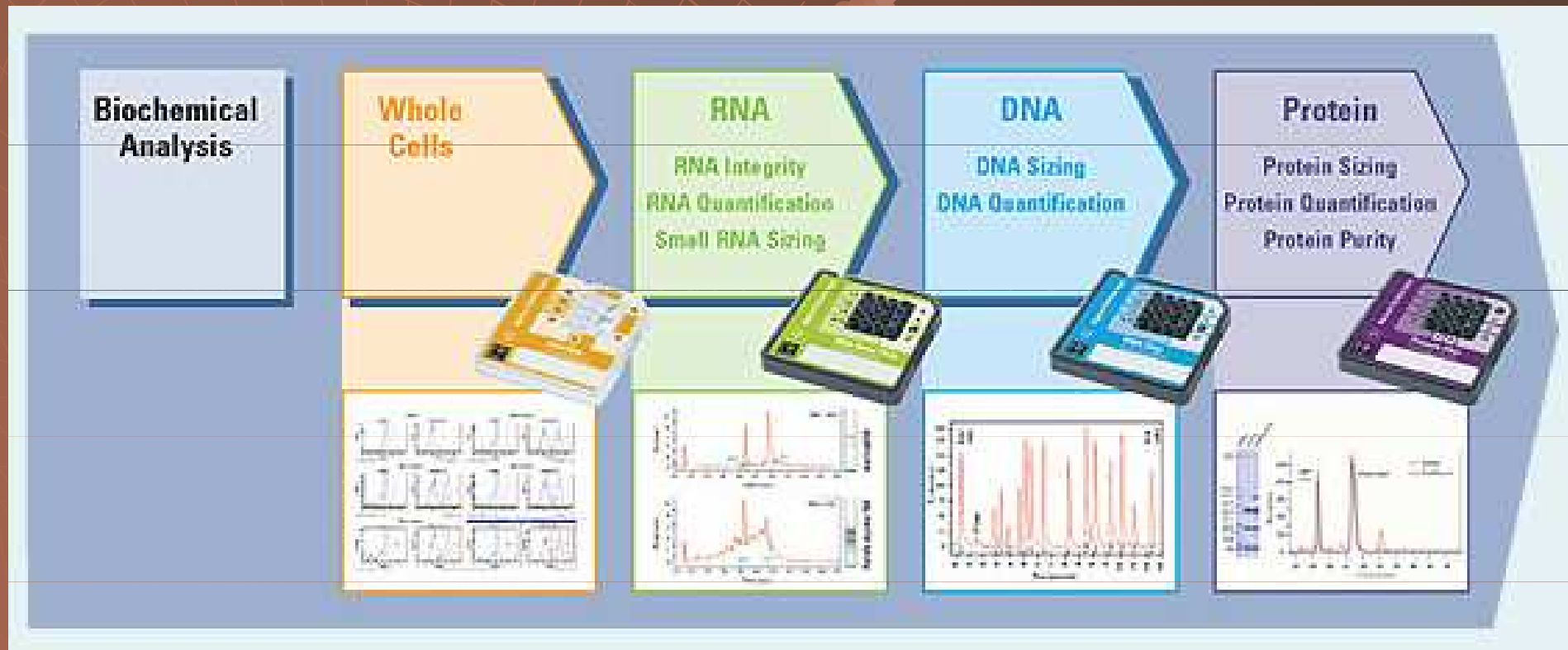

2013 NASA - Mars

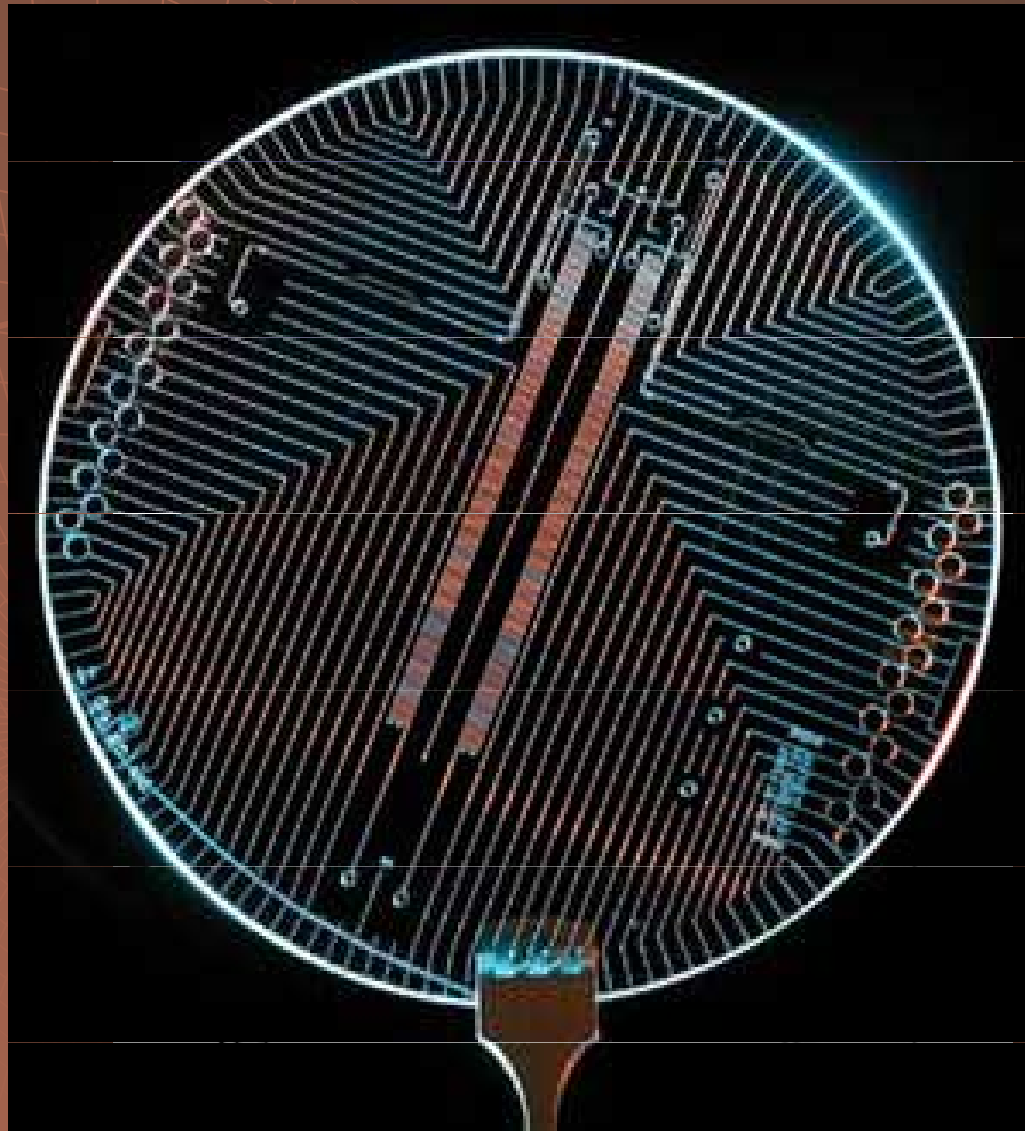

Afinitní elektroforéza

„V inertní matrici je imobilizován ligand, se kterým specificky interaguje separovaný biopolymer“

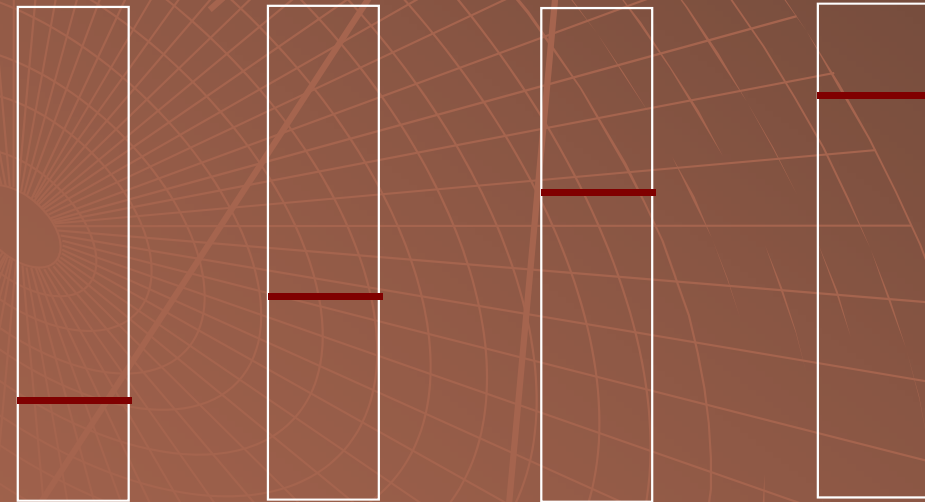

$$c_L = 0$$

$$c_L = n$$

$$c_L = 2n$$

$$c_L = 4n$$

Ligandy

Biopolymery	Ligandy
Enzymy	substrát, koenzym, inhibitor
Hormony	receptory
Lektiny	sacharidy
NK	NK

Imobilizace ligandu

- ◆ Chemická – kovalentní vazba
- ◆ Fyzikální – ligand vázán na makromolekulu
- ◆

Použití :

Studium interakce mezi ligandem a biomakromolekulou

Izoelektrická fokusace

*„Elektroforéza v gradientu pH,
částice jsou separovány podle
svých pI“*

Izoelektrická fokusace

1961 Svensson – Rilbe (1968)

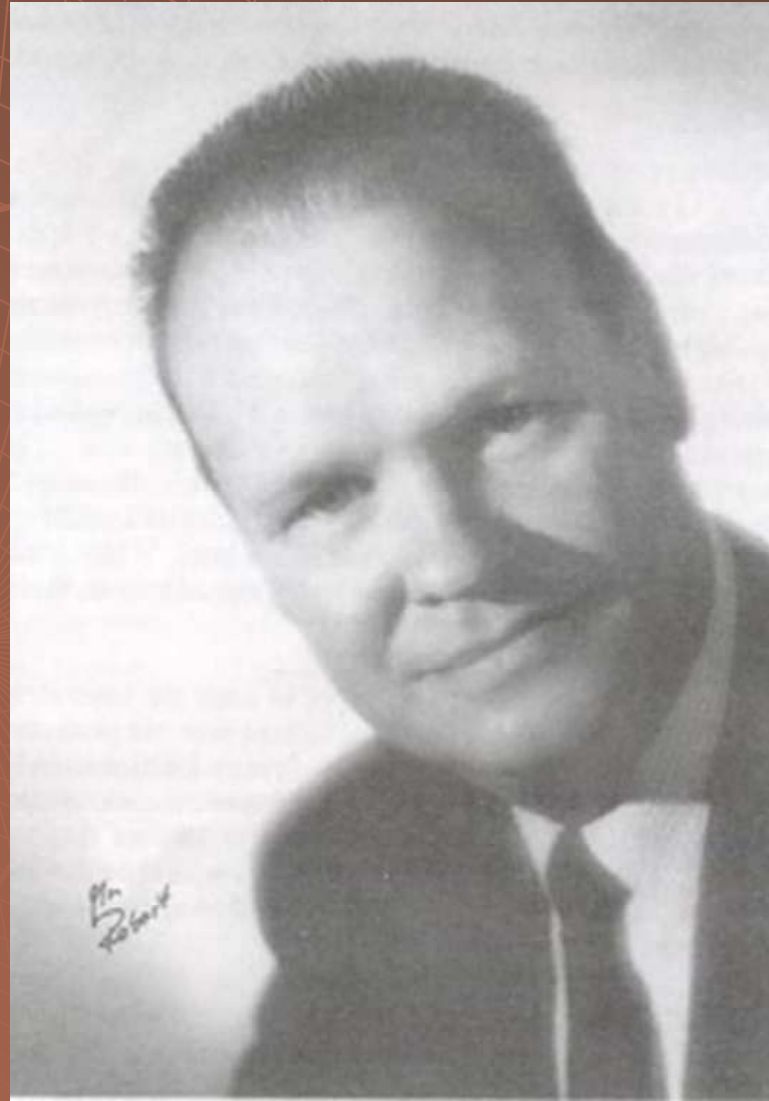

Tvorba gradientu



Ampholyty

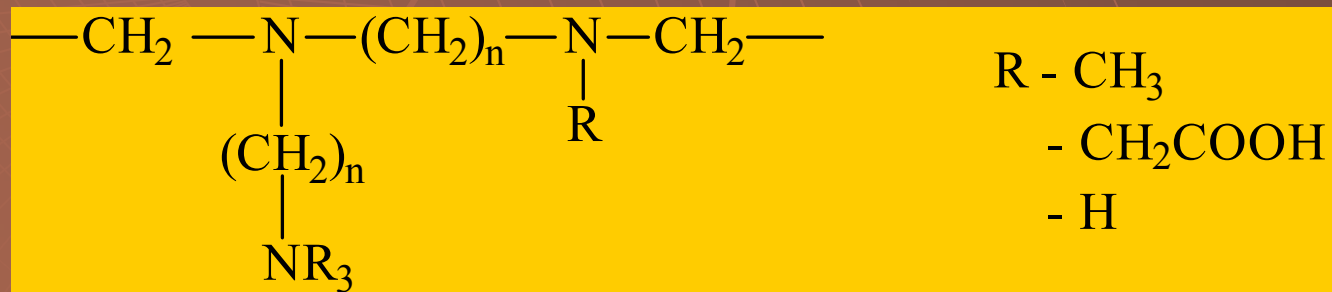

Izoelektrická fokusace

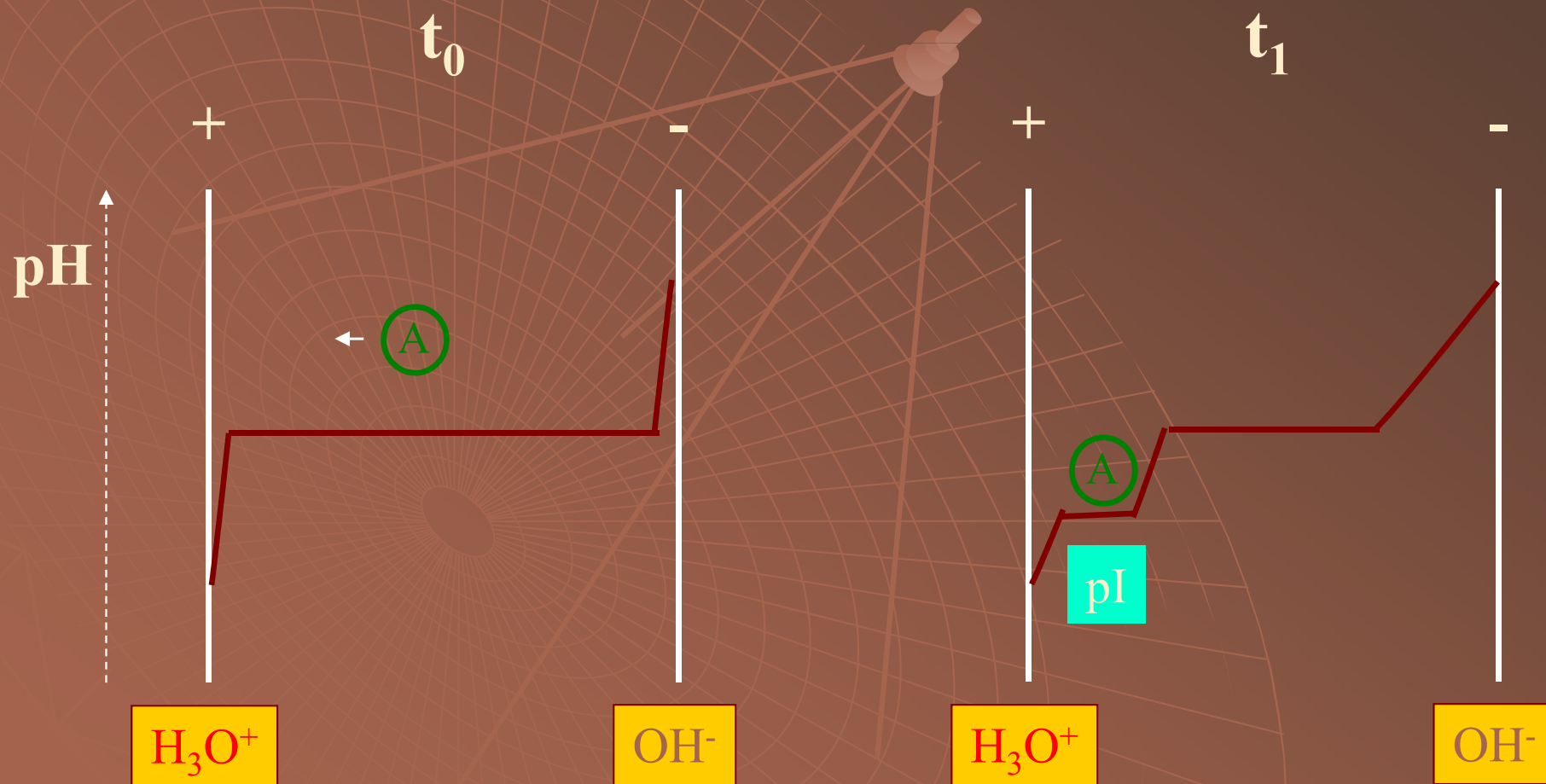

Izoelektrická fokusace

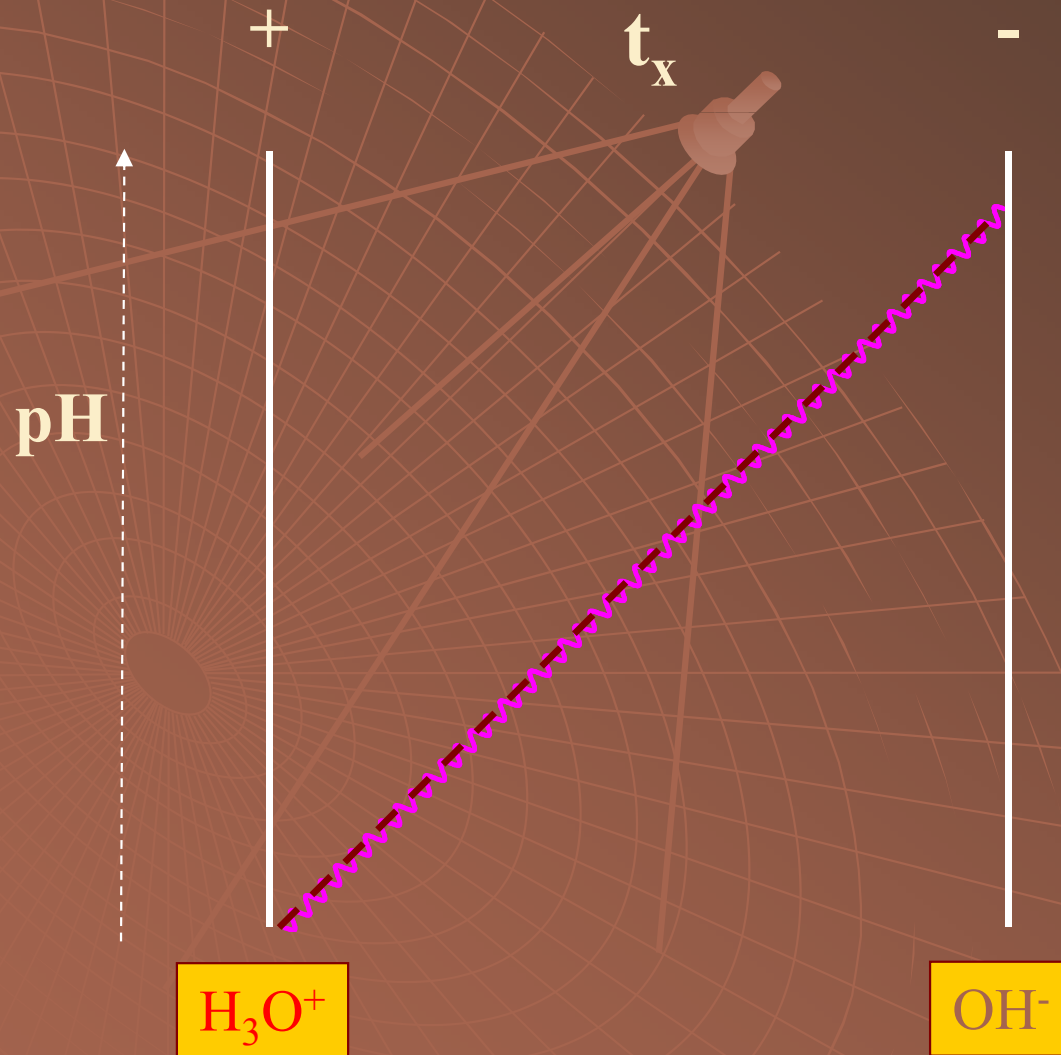

Kapilární izoelektrická fokusace

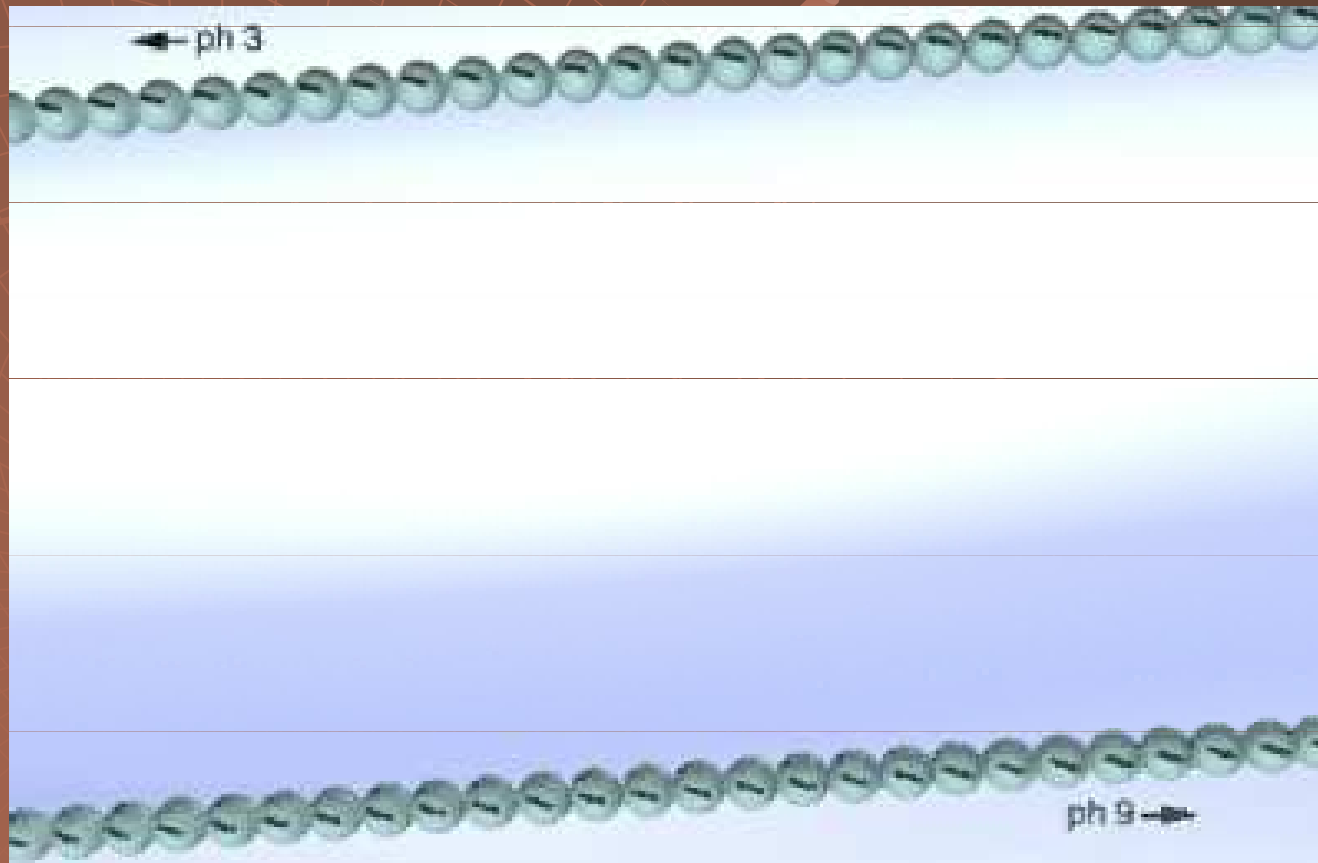

Izoelektrická fokusace analytická

- ◆ Provedení - v gelech – PAGE, agarosa
- ◆ Použití - sledování komplexních směsí
 - izoenzymové složení
 - stanovení pI – rozřezání a eluce
 - μpH elektrody
 - pI standardy

Izoelektrická fokusace analytická



Izoelektrická fokusace analytická

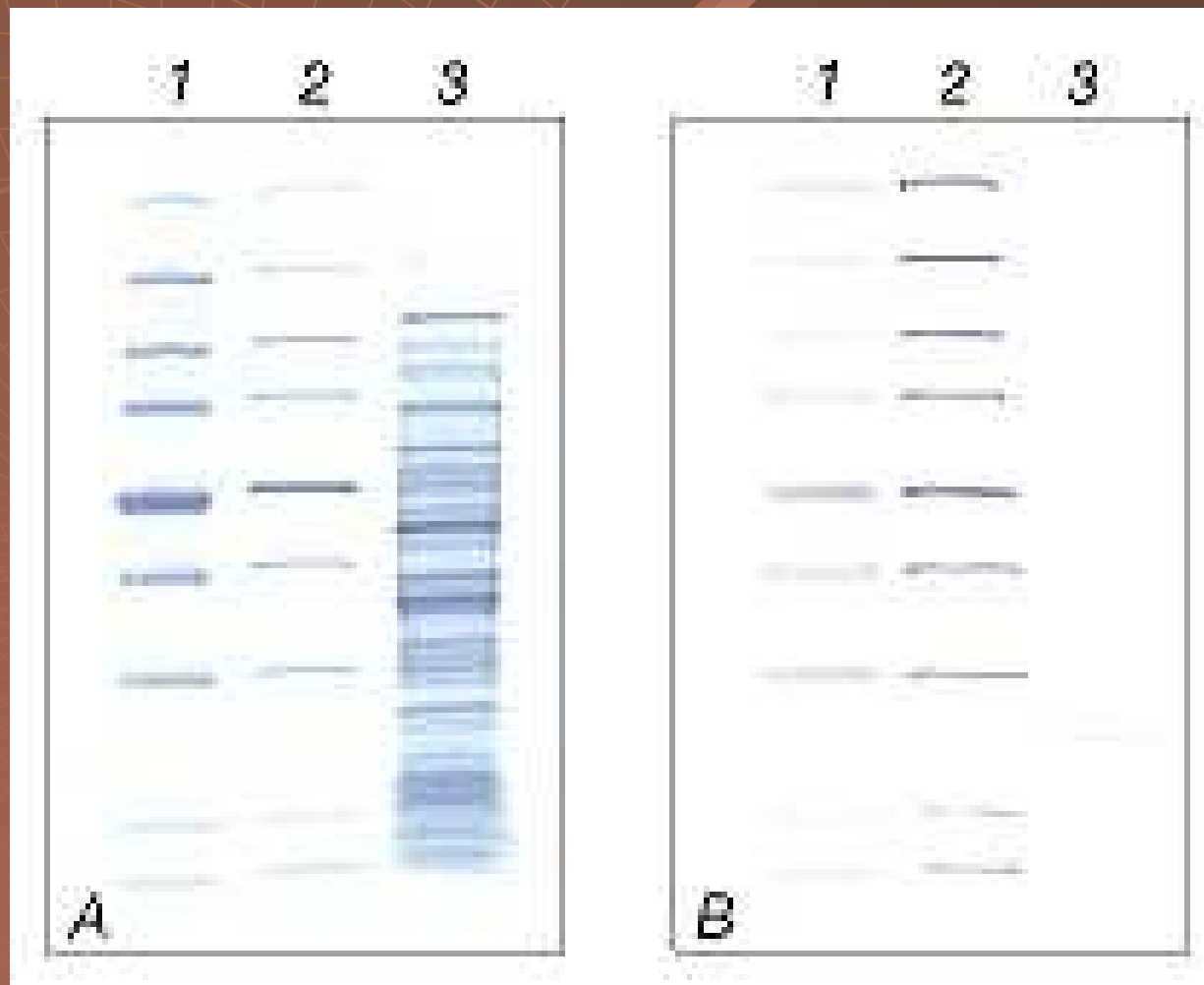

Izoelektrická fokusace analytická - standardy

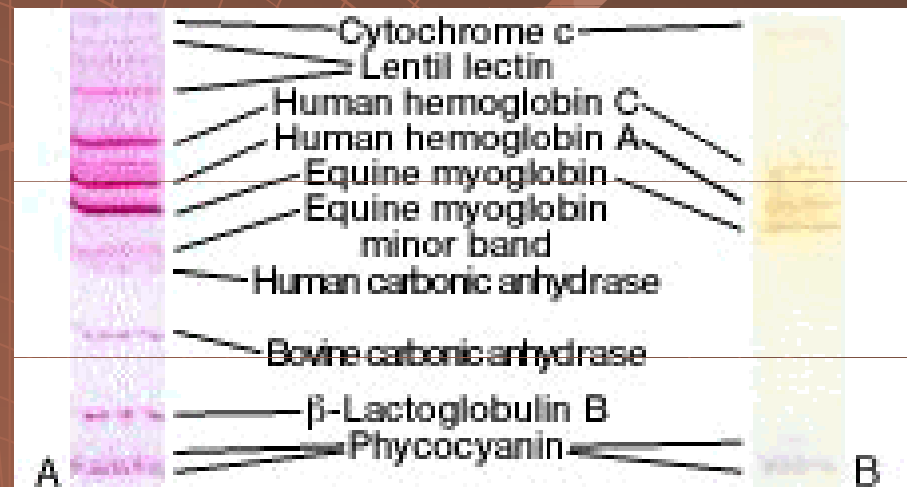

IEF Standards for accurate pI calibration of native IEF gels. A. 5 μ l of the standards were stained with Coomassie blue R-250 dye and cresyl scarlet. B. 5 μ l of the standards were left unstained.

Izoelektrická fokusace

Imobiline

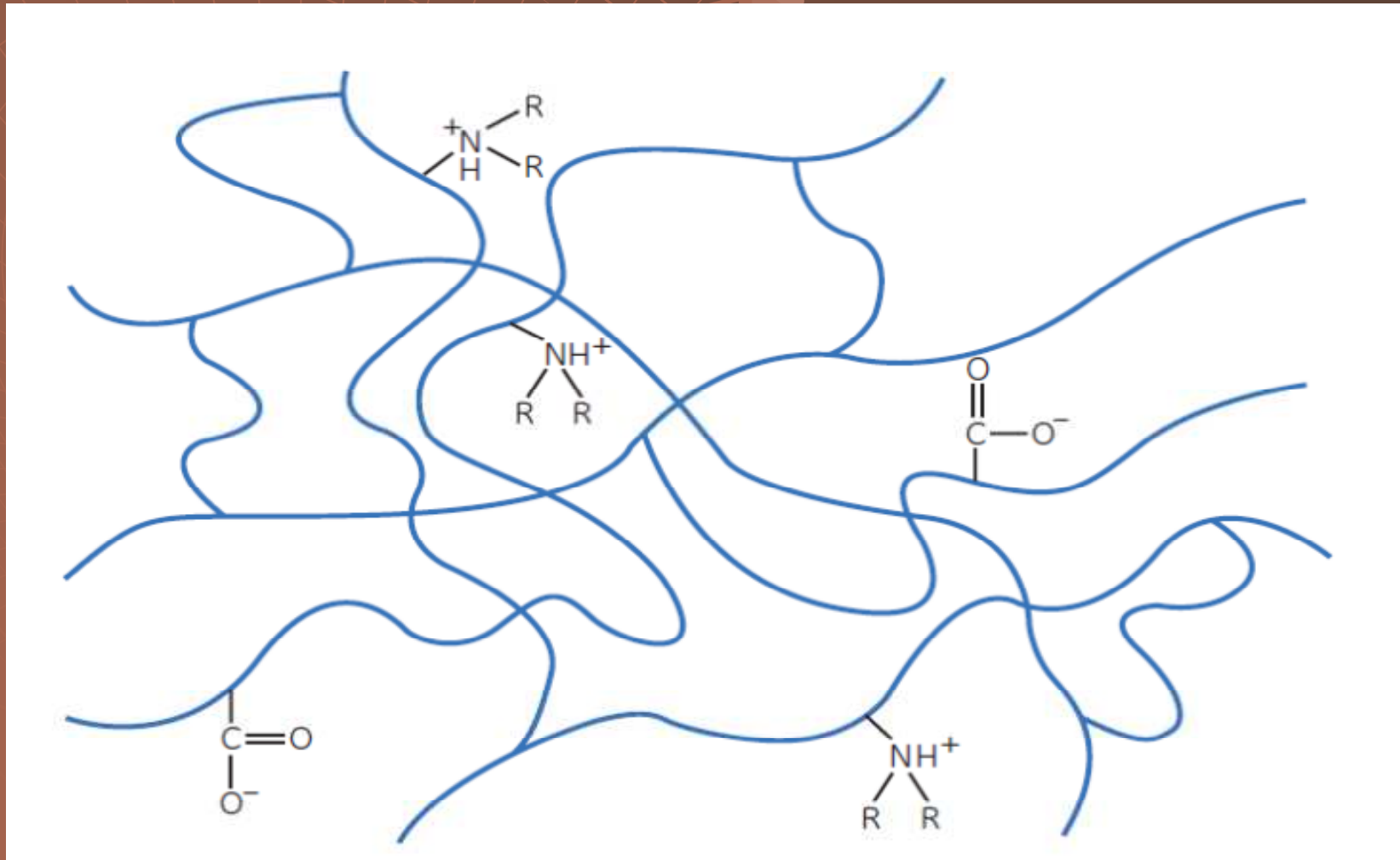
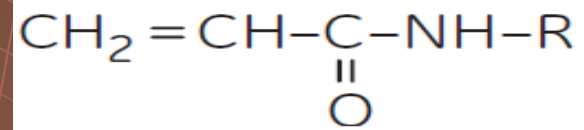

Izoelektrická fokusace preparativní

- ◆ Provedení - rotací – Rotofor (BioRad)



A



B

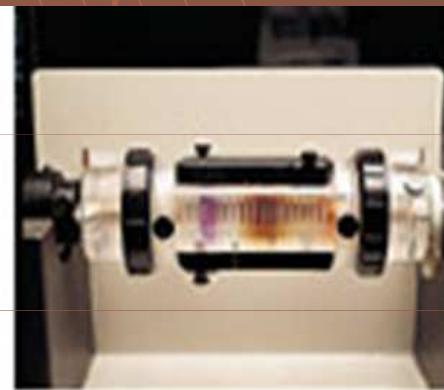

C



D

Izoelektrická fokusace preparativní

- ◆ Provedení - v sypaných vrstvách (Sephadex)
 - v gradientech hustoty (sacharóza)

Použití – izolace bílkovin

Dvourozměrné metody

- ◆ Metoda titračních křivek
- ◆ Dvourozměrná elektroforéza

Metoda titračních křivek

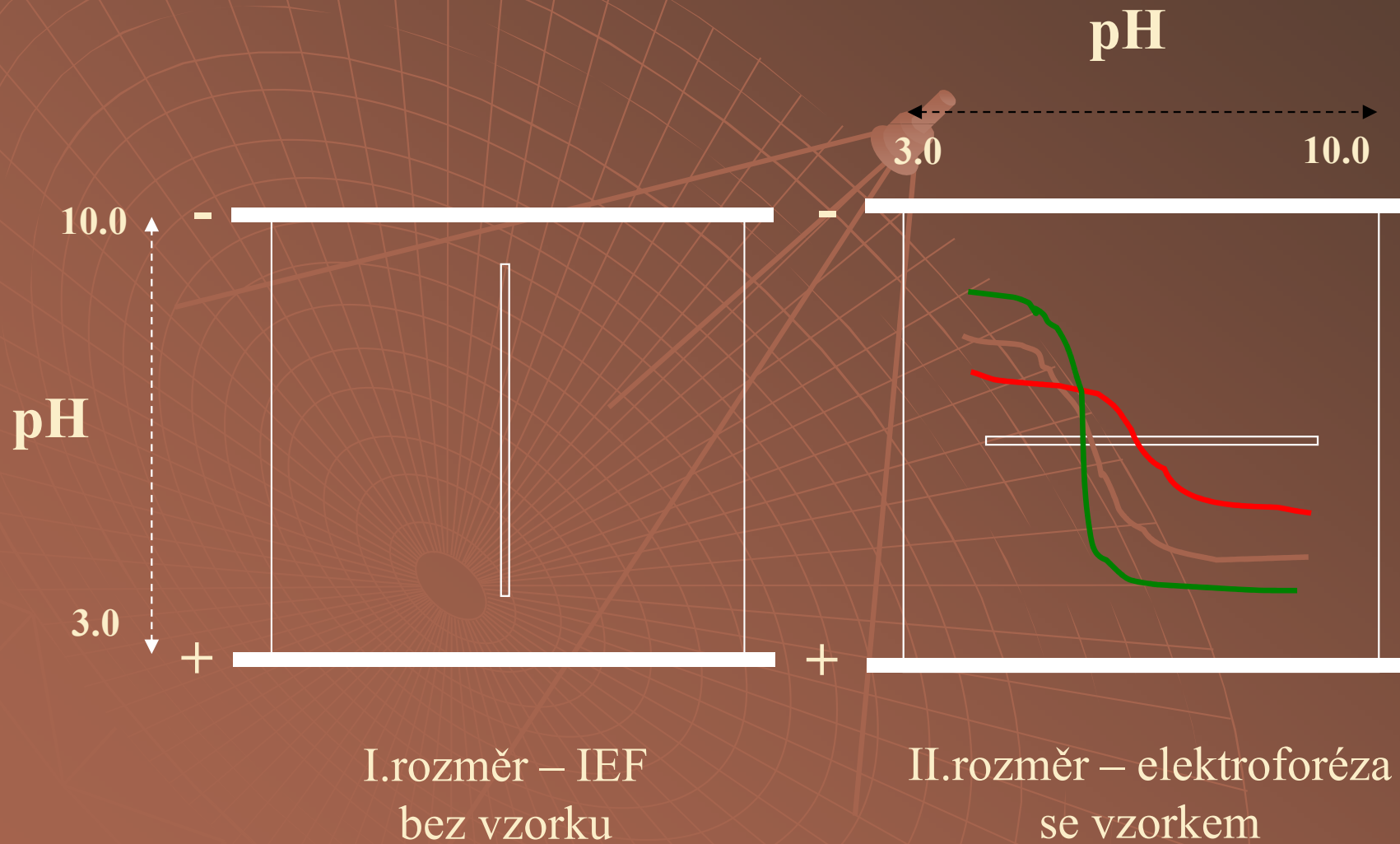

Metoda titračních křivek

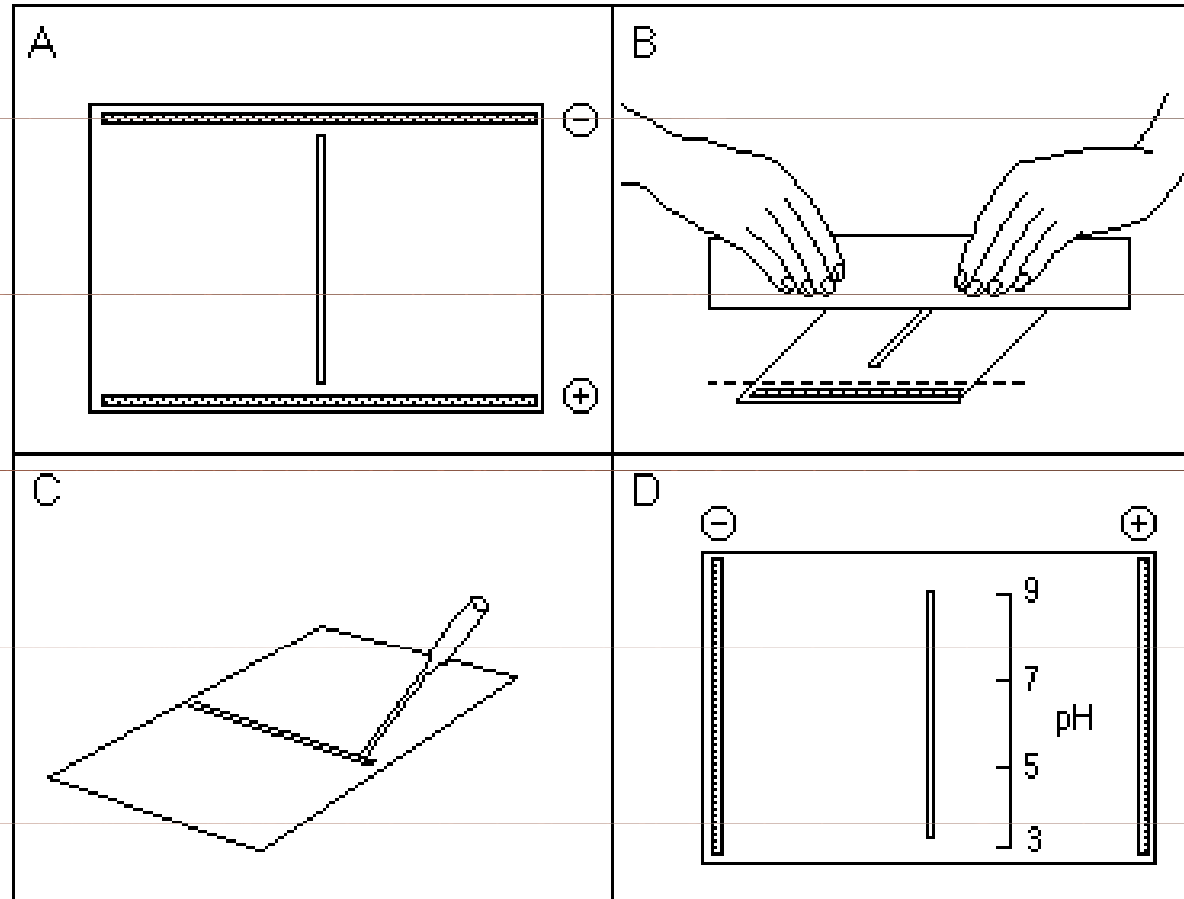

Metoda titračních křivek

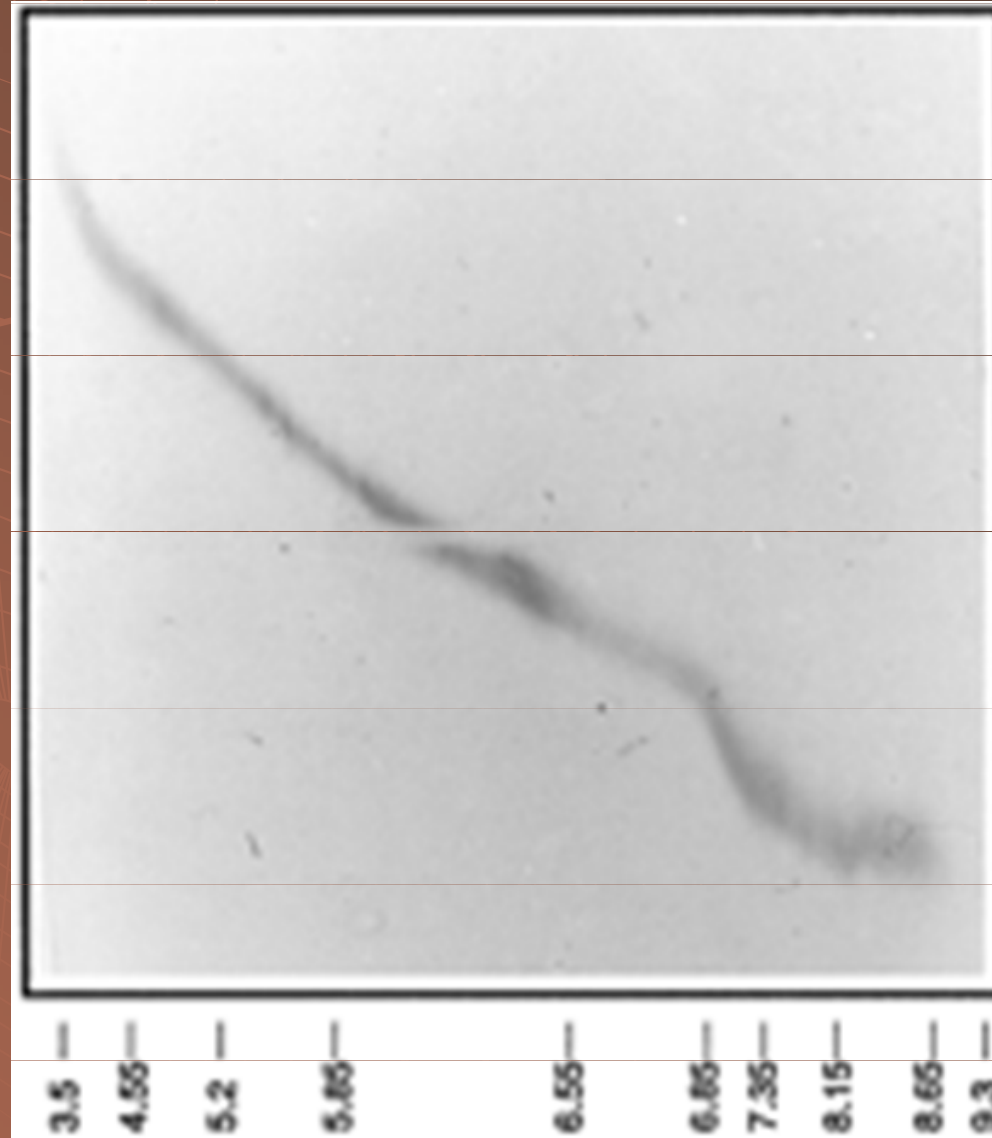

Metoda titračních křivek

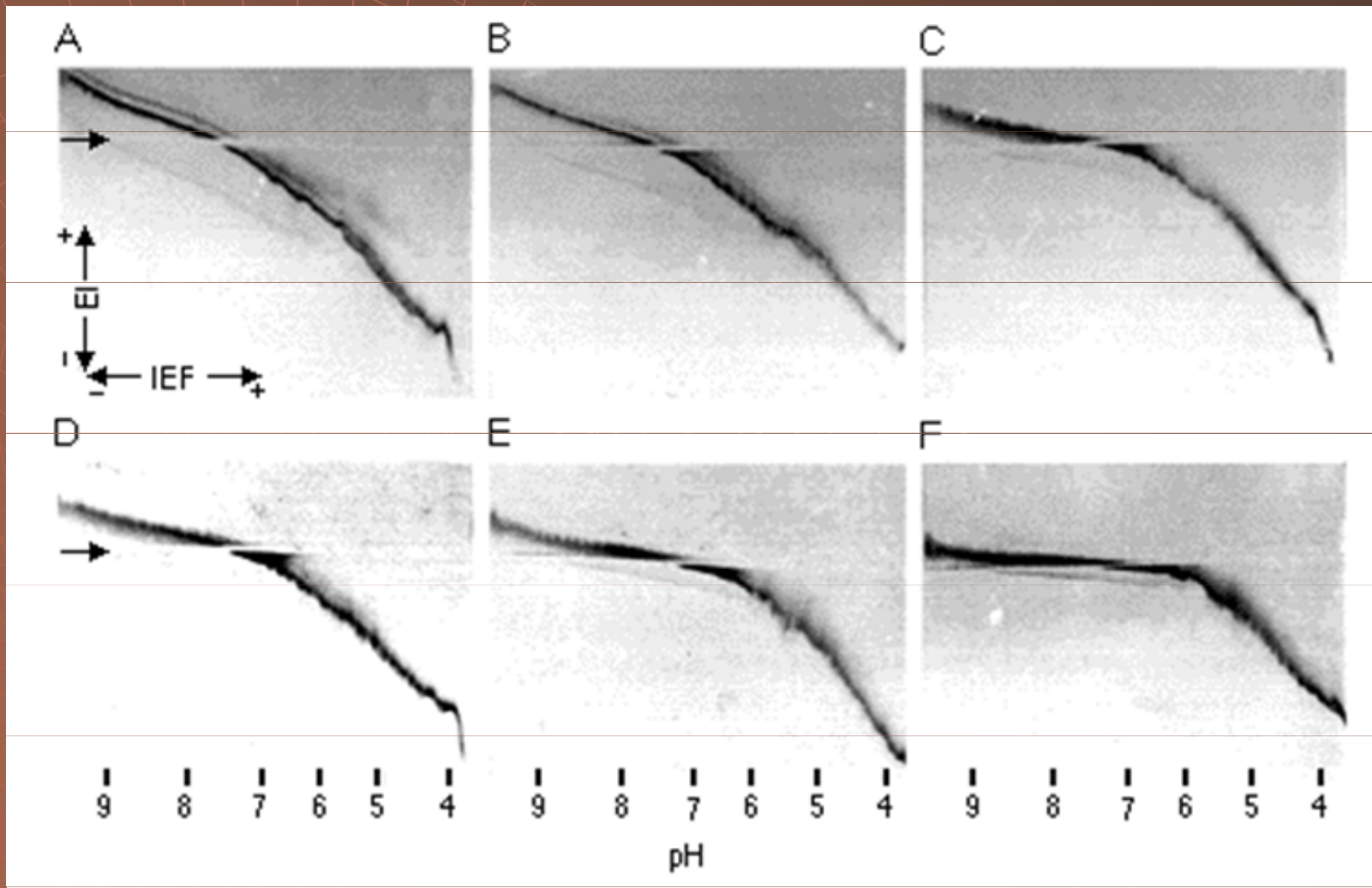

Dvojměrná elektroforéza

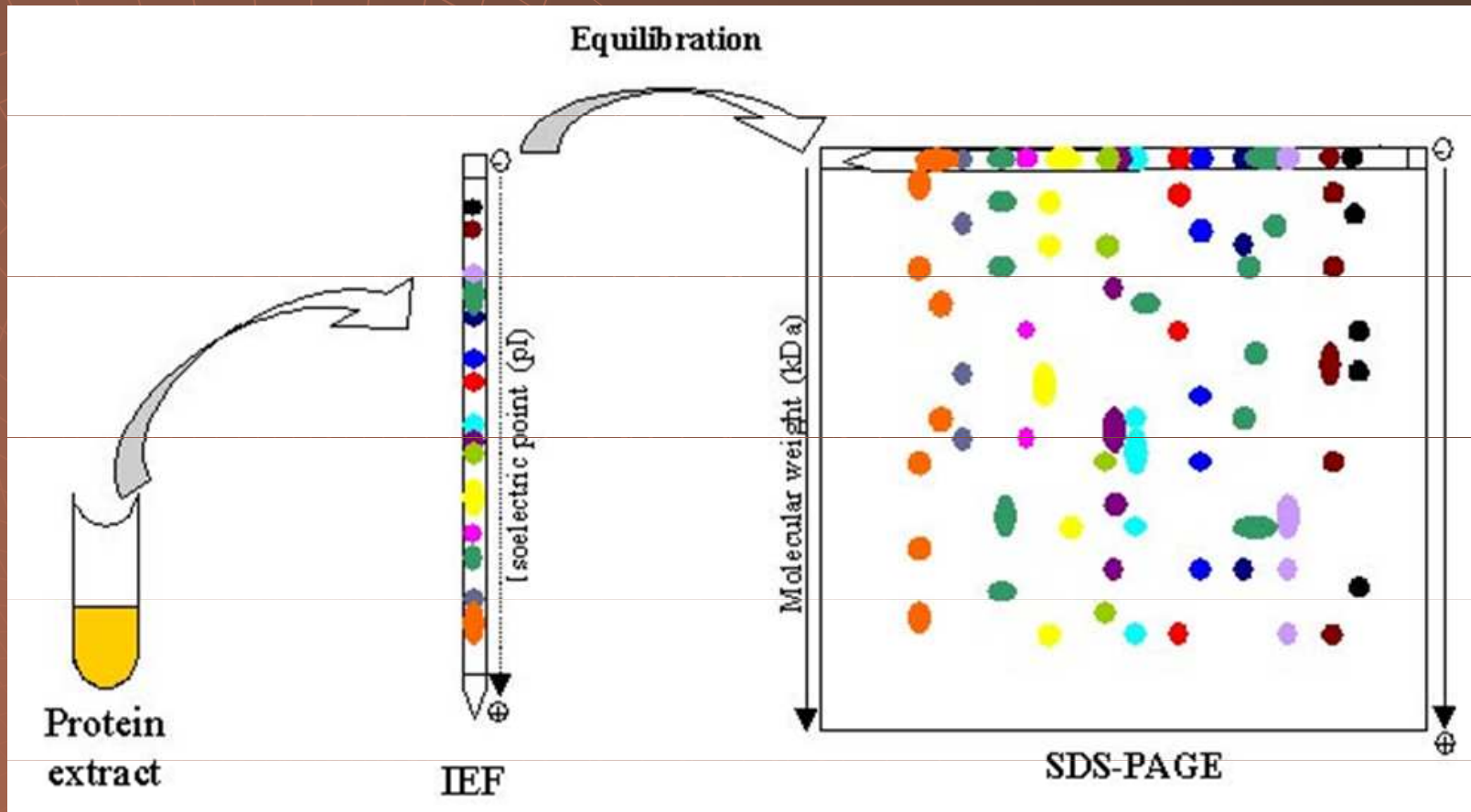

Dvojměrná elektroforéza

1975 O'Farrell

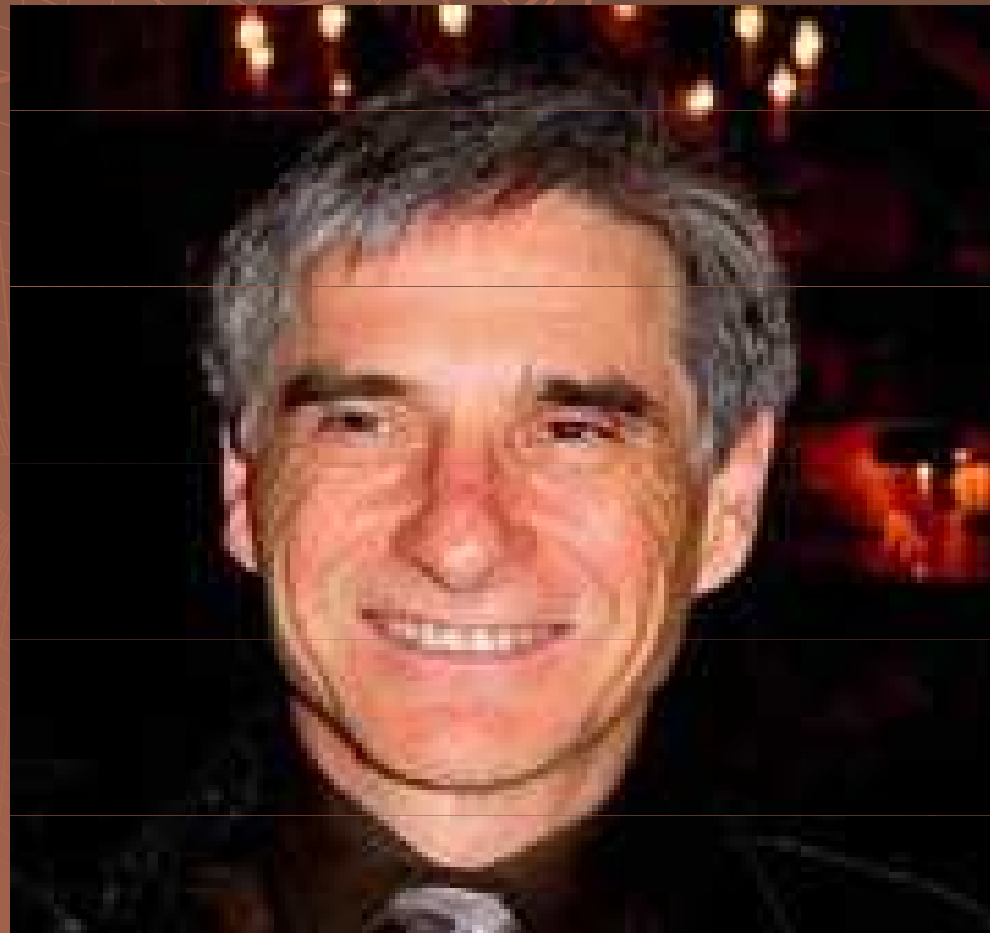

Dvojměrná elektroforéza

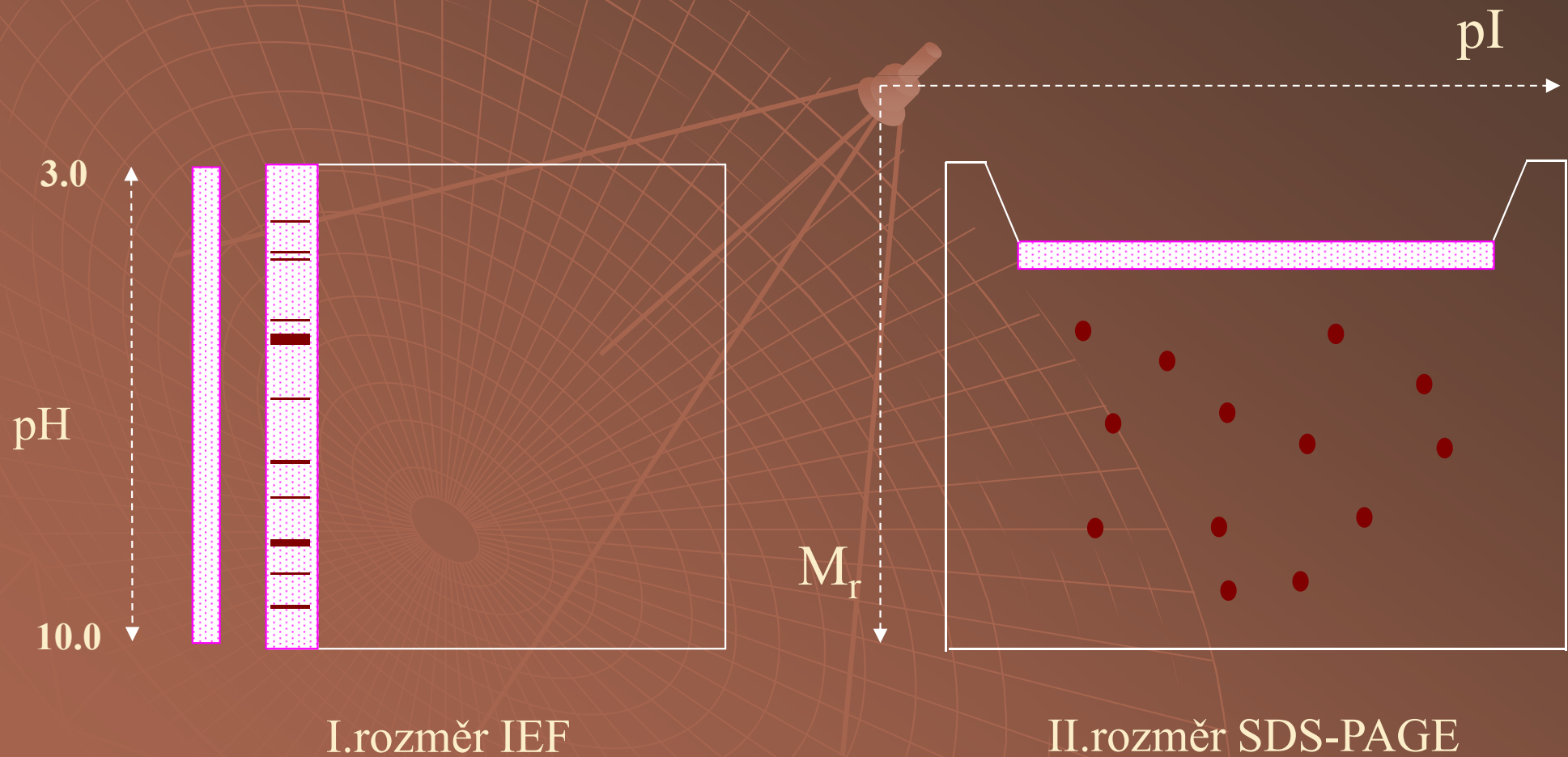

Dvojměrná elektroforéza

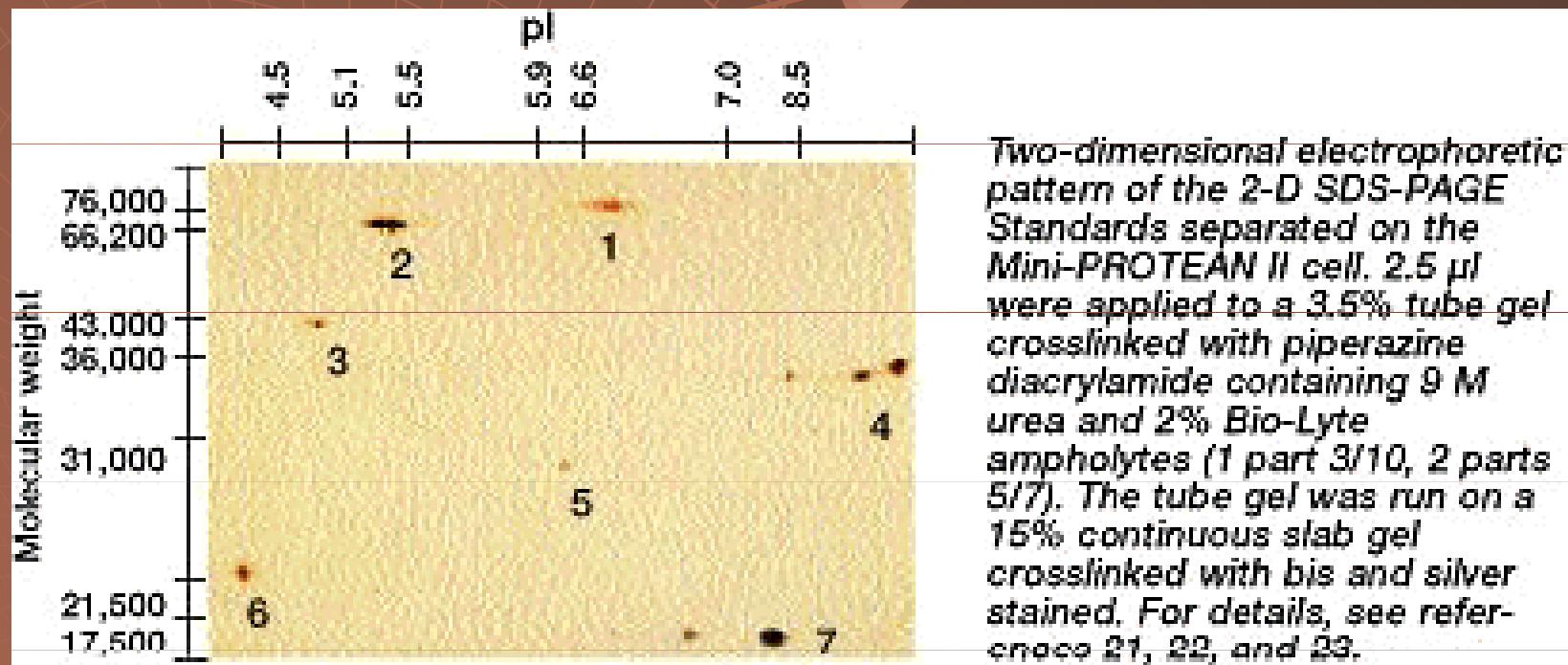

Dvojměrná elektroforéza



Základní schéma analýzy užívané v proteomice

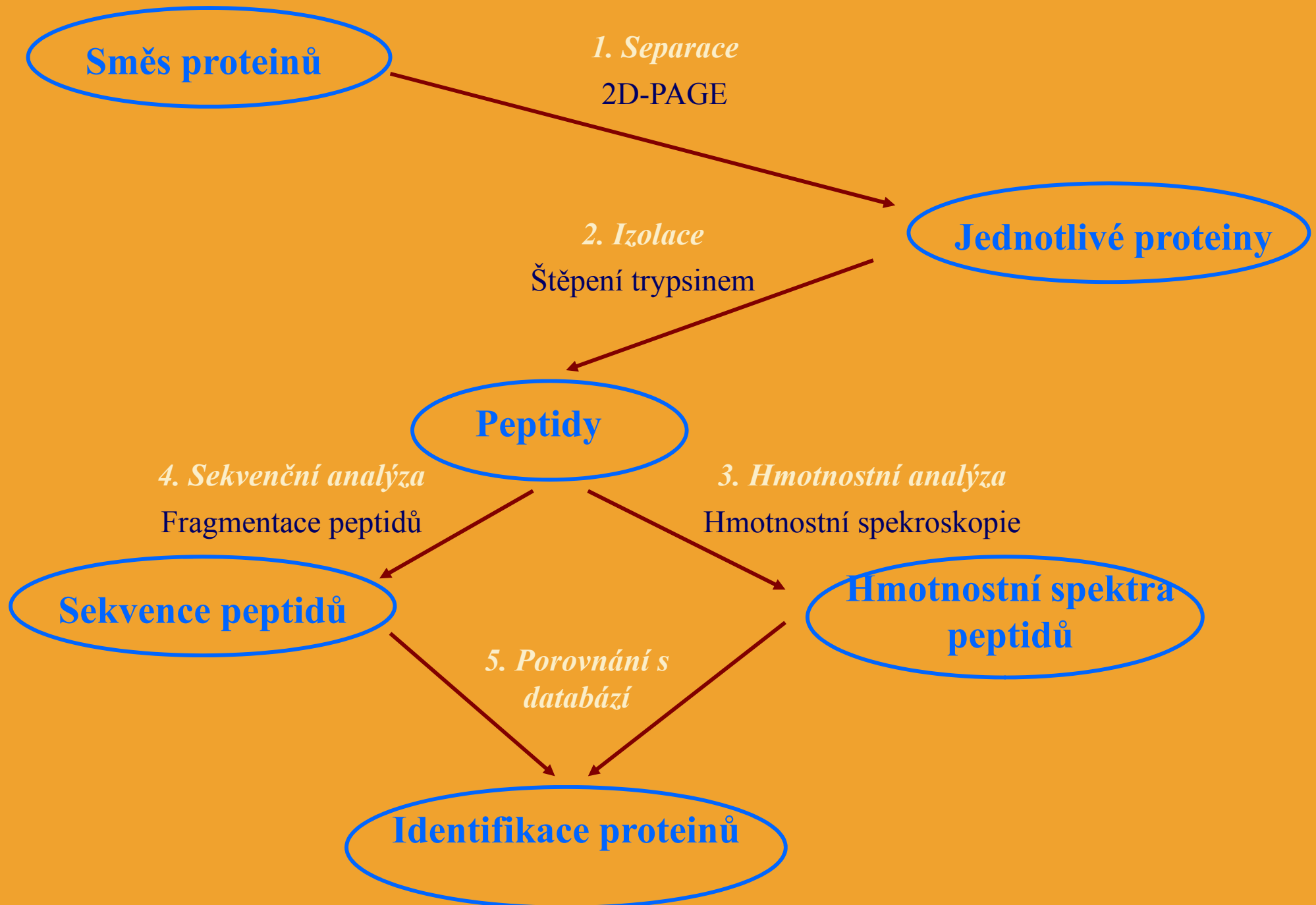

CompuGen Z3 DeskTop v.1.11.Beta

File Edit Image Spots Align View Analysis Window Log Help

[1st] 2small [2nd] 1small

Layered View: 2small vs. 1small

Matching Data Table

The gels in the table are enumerated as follows:

1. 2small
2. 1small

ID	X1	Y1	RE1	X2	Y2	RE2	std	baseline
1016	346	39	6031	337	43	11053	2511.0	0.508
1022	255	45	3712	250	51	3745	16.5	0.009
1023	242	48	2206	237	53	2921	357.5	0.279
1024	119	49	584	125	53	1076	246.0	0.593
1025	100	50	3290	108	54	4738	724.0	0.361
1027	183	50	2104	183	53	3515	705.5	0.502
1029				35	52	1150		
1030	221	52	5409	217	56	4496	456.5	-0.184
1032				264	52	4886		
1033				275	52	1422		
1034	147	53	3078	151	59	1281	898.5	-0.625
1038	290	56	1992					
1040				35	57	1006		

[142, 129] -> [1st: 127 2nd: 184]

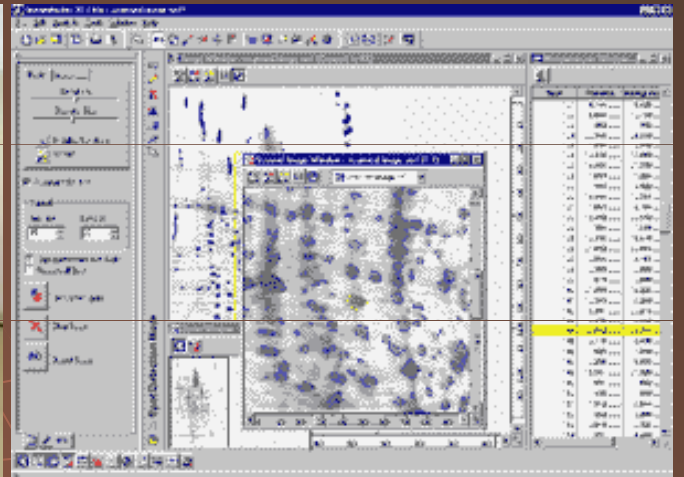

DIGE – DIFERENČNÍ GELOVÁ ELEKTROFORESA

Cy2

Cy3

Cy5

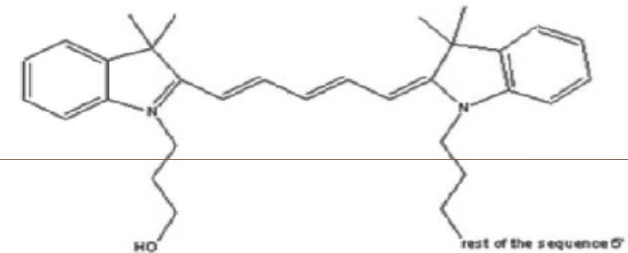
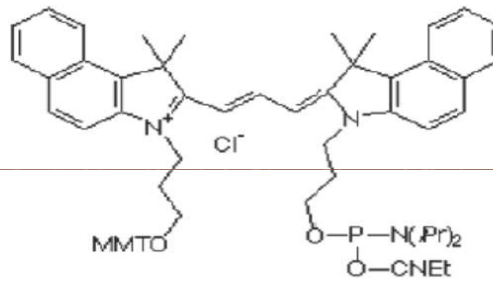

excitace 488 nm
emise 520 nm

excitace 532 nm
emise 580 nm

excitace 633 nm
emise 670 nm

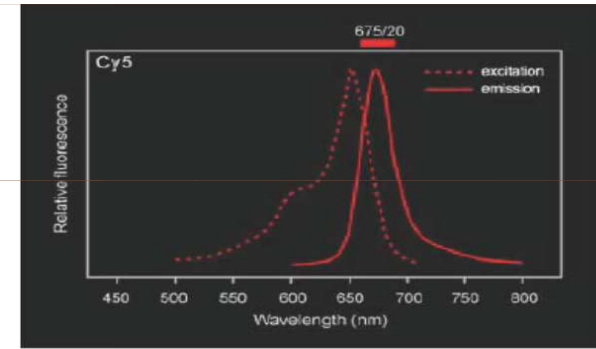
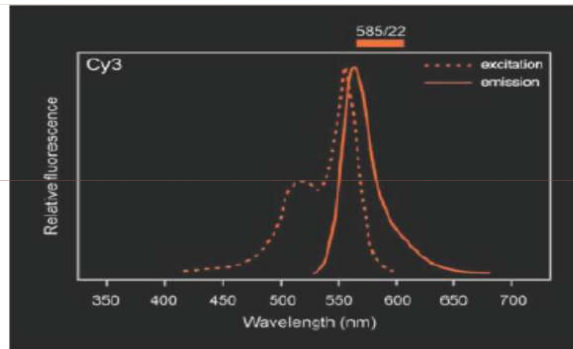
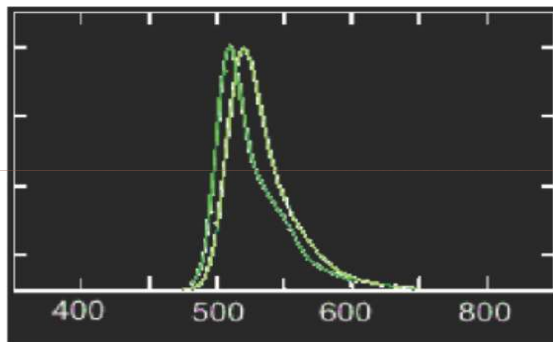

A

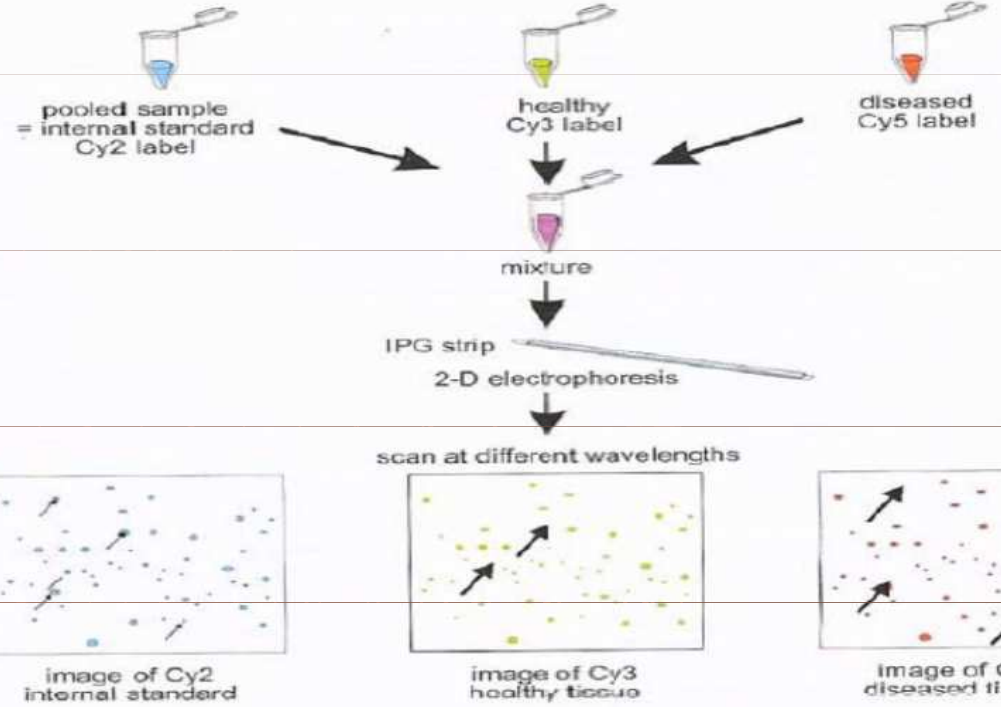

B

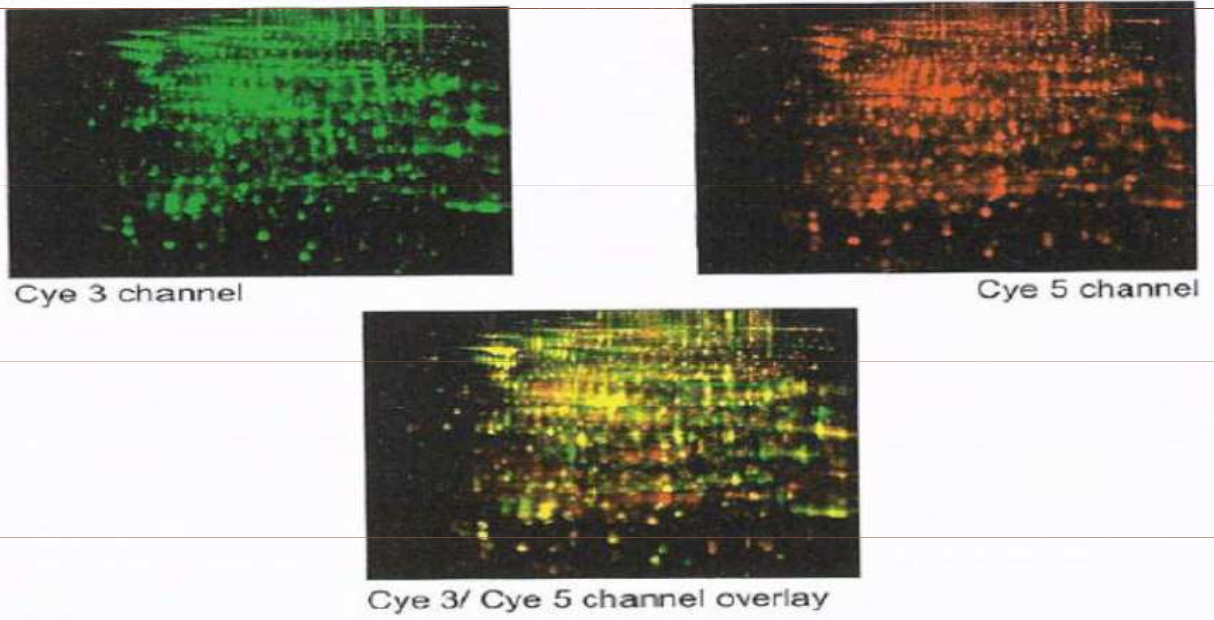

Izotachoforéza

„Vzorek je umístěn mezi dva elektrolyty : vedoucí L (leading) s nejvyšší mobilitou a - uzavírající T (terminating) s nejmenší mobilitou“

Izotachoforéza

1976 Everaerts



Izotachoforéza

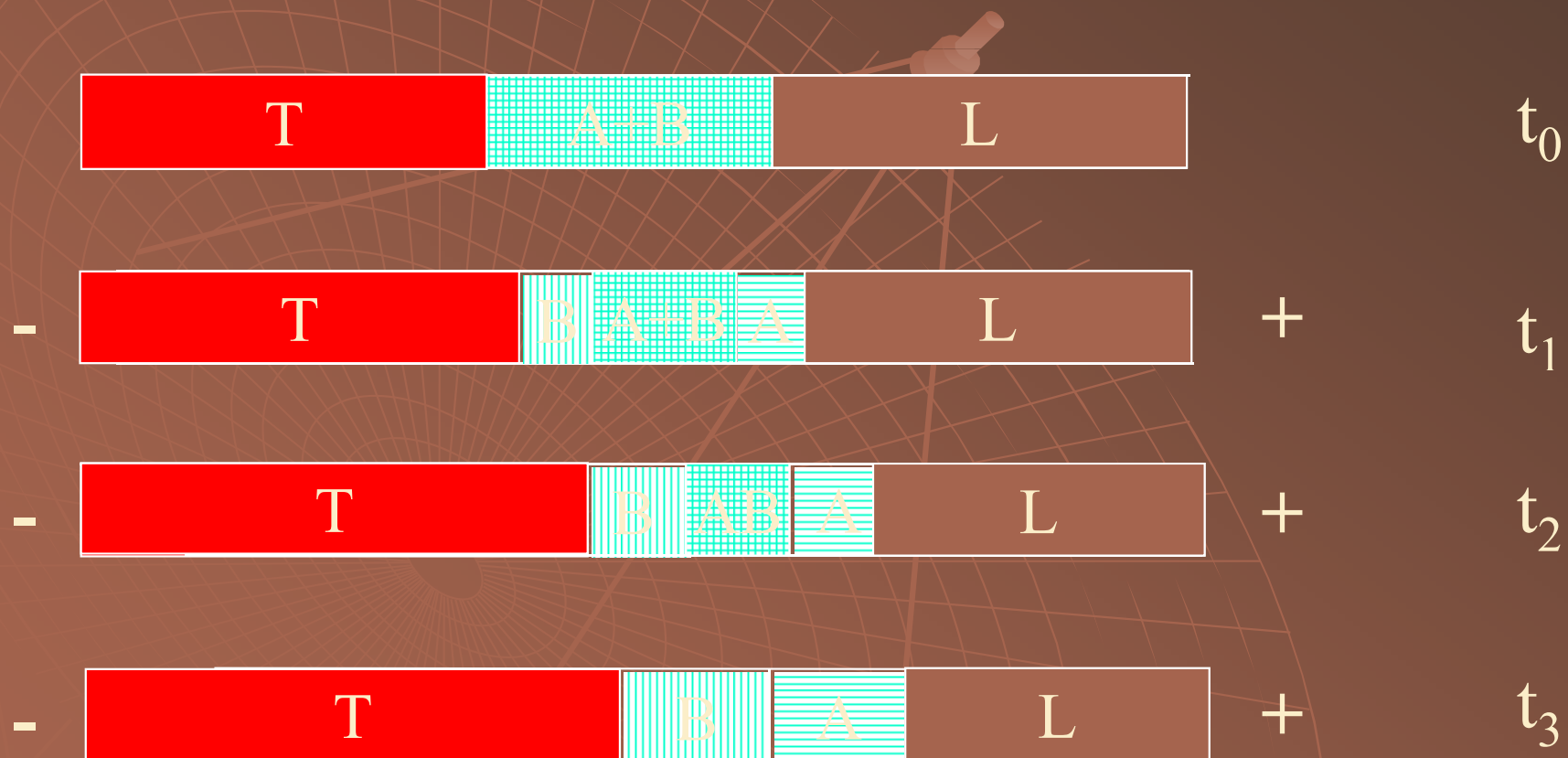

Izotachoforéza

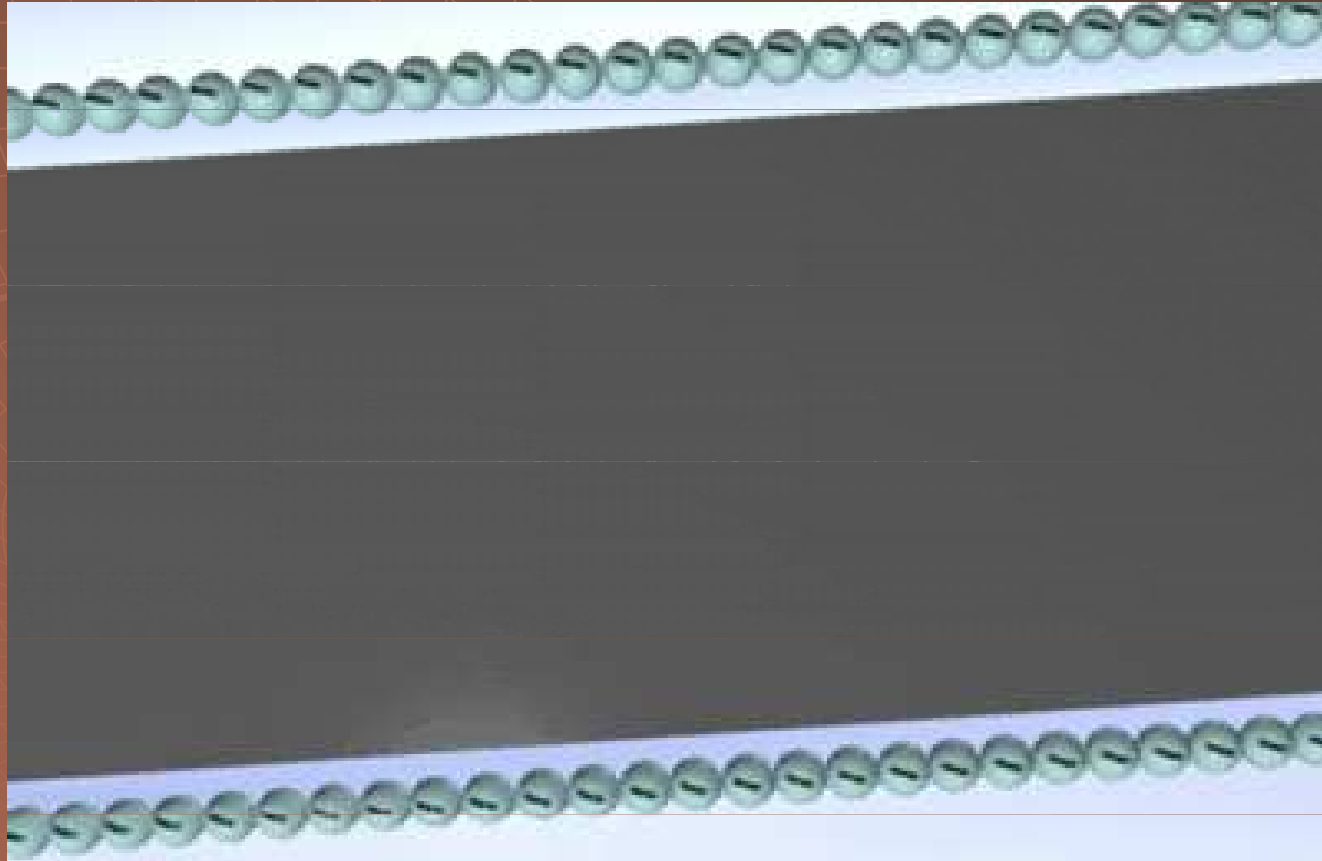

Izotachoforéza

$$\mu_L > \mu_A > \mu_B > \mu_T$$

$$\mu = \frac{v}{E}$$

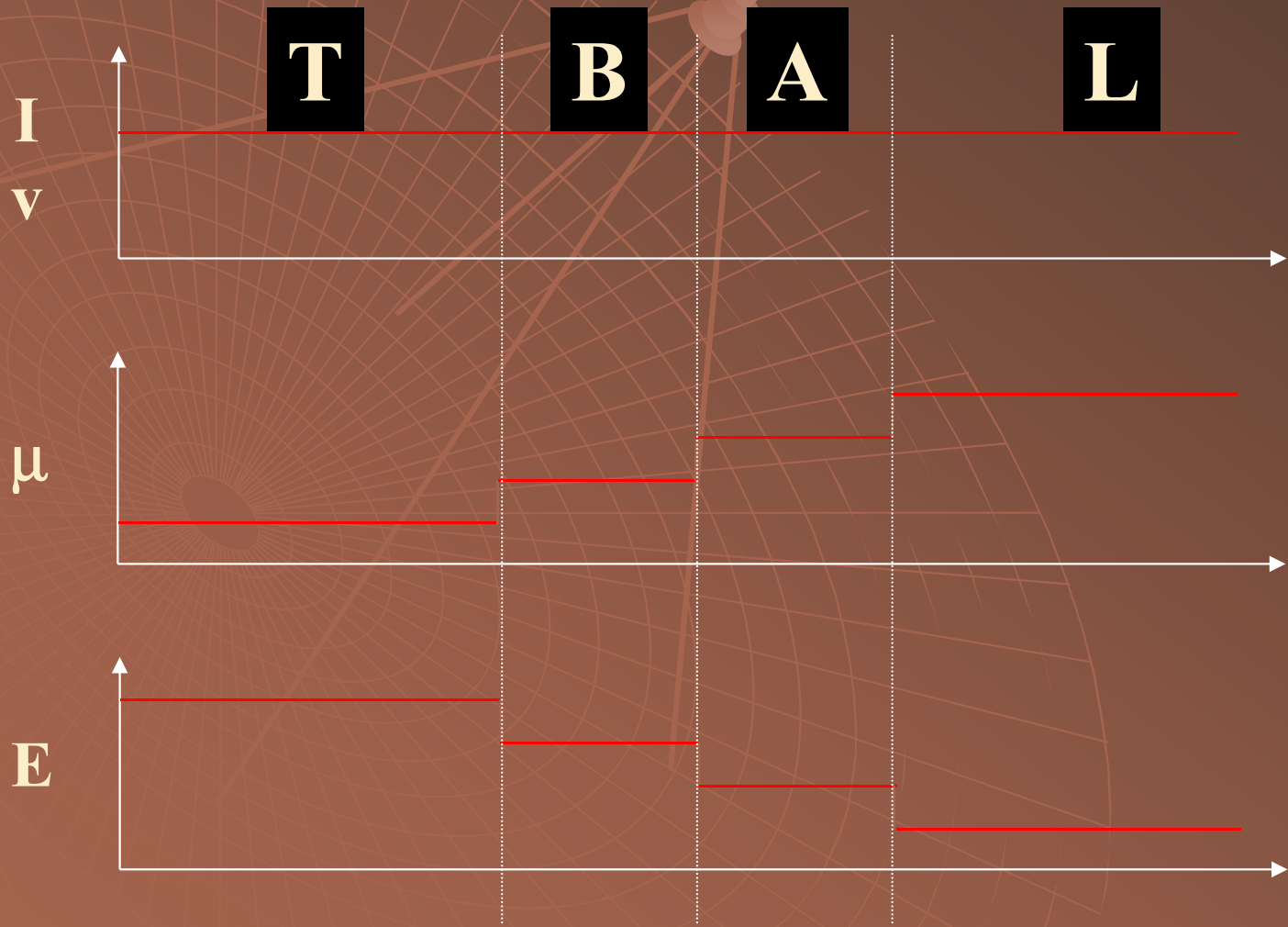

Kohlrauschova regulační funkce

$$\sum_i \sum_z \frac{|z| c_i}{\mu_i} = K_x$$

$$c_i = c_L \cdot \frac{\mu_L + \mu_R}{\mu_L} \cdot \frac{\mu_i}{\mu_i + \mu_R} \cdot \frac{z_L}{z_i}$$

Analytická ITP

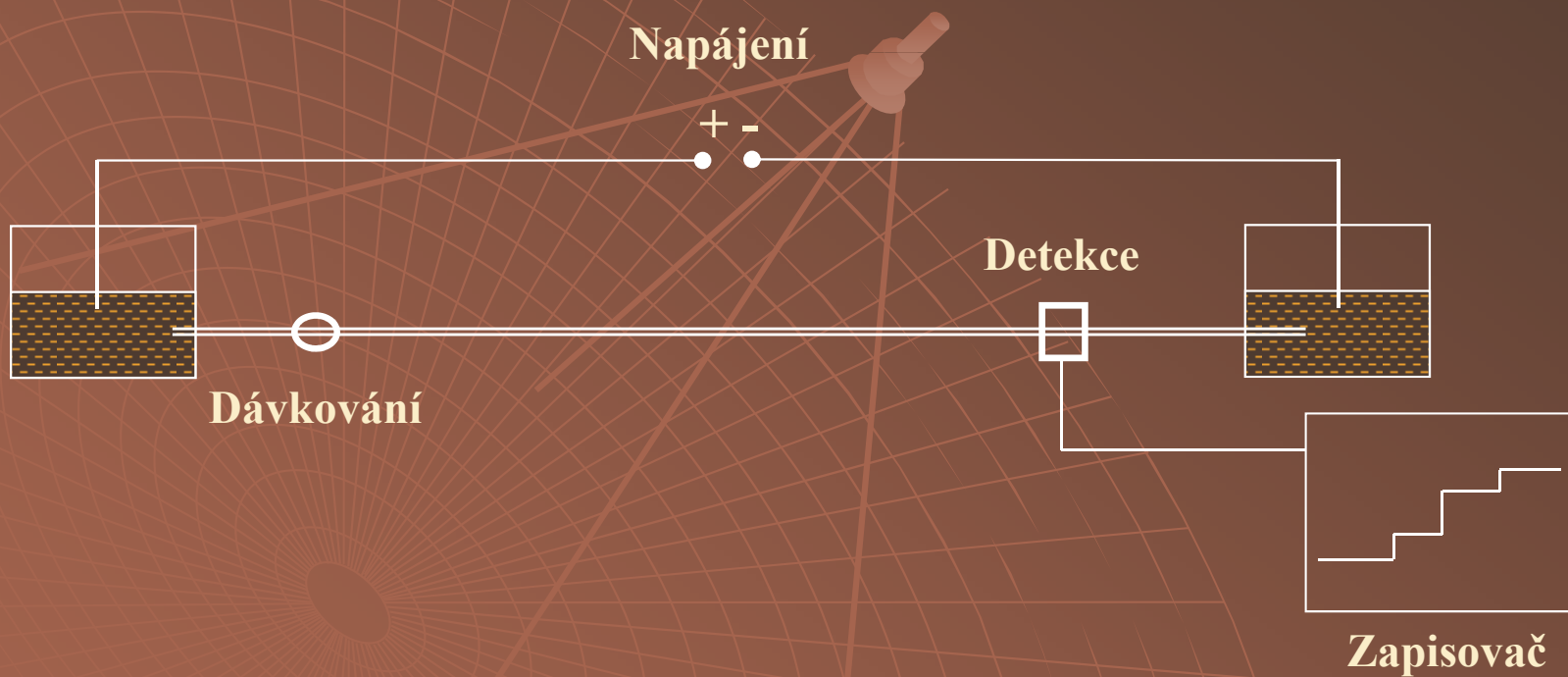

Analytická ITP instrumentace

- ◆ Napájení - stejnosměrné 3 kV 0,2 – 0,5 mA
- ◆ Kapilára 0,1 – 2 mm
- ◆ Dávkování - dávkovací ventil
- ◆ Detekce - universální – konduktometrická
– potencialně gradientová
- selektivní – UV-VIS

Izotachoforetický záznam kvantita

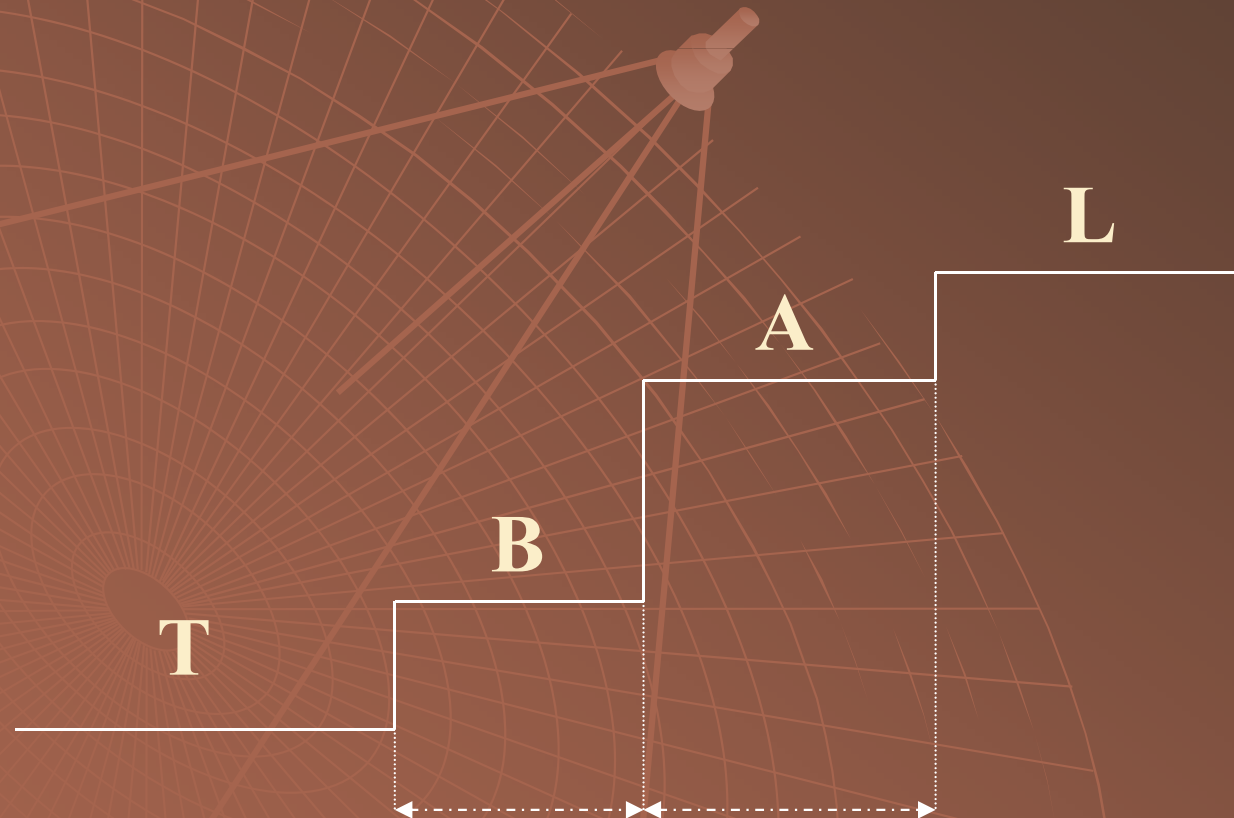

Izotachoforetický záznam kvalita

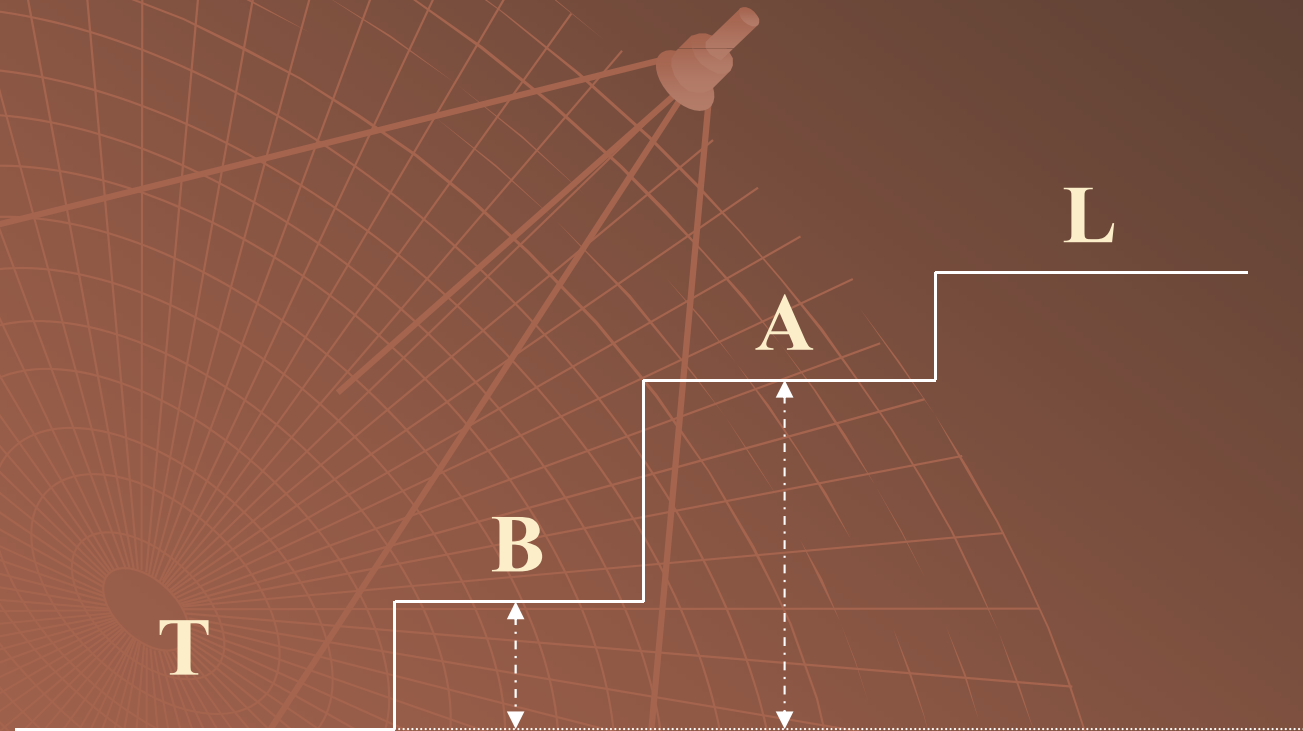

Izotachoforetický záznam

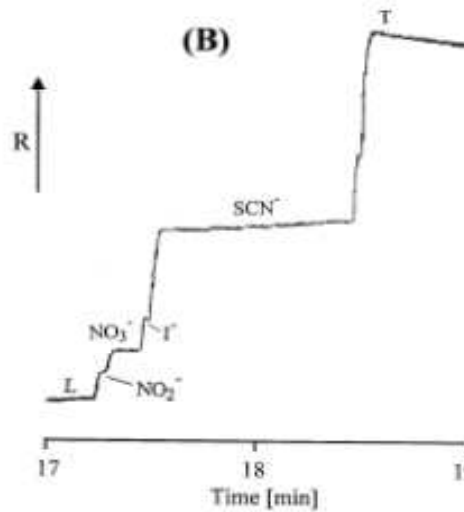
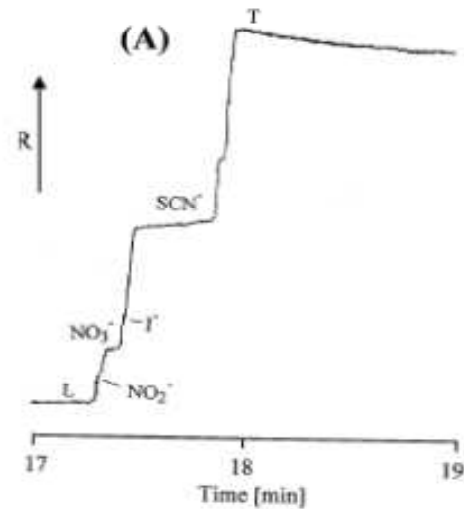
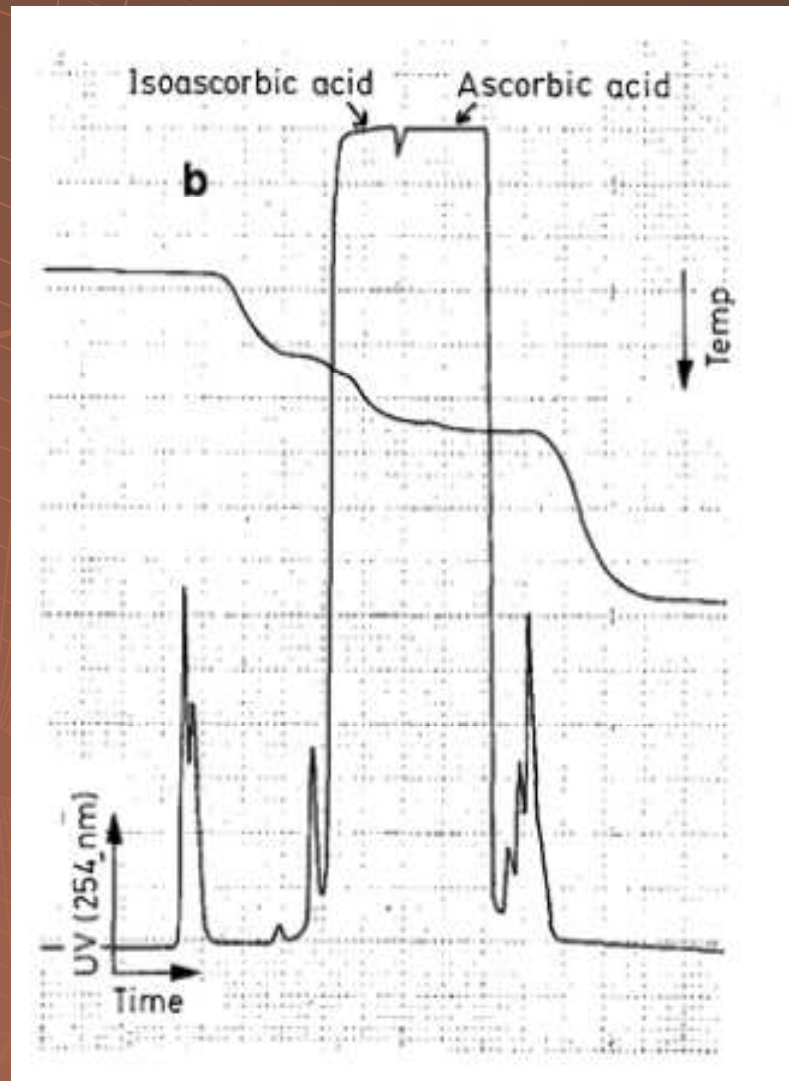

Fig. 2 Isotachopherograms of non-smoker saliva (A) and smoker saliva (B). L, leading ion (chloride); T, terminating ion (acetate); R, increasing resistance.

Izotachoforetický záznam



Analytická ITP Villa Labeco



Analytická ITP

Metoda spojování kapilár



Preparativní ITP

V gelech - Sephadex



Preparativní ITP

Kontinuální plošná

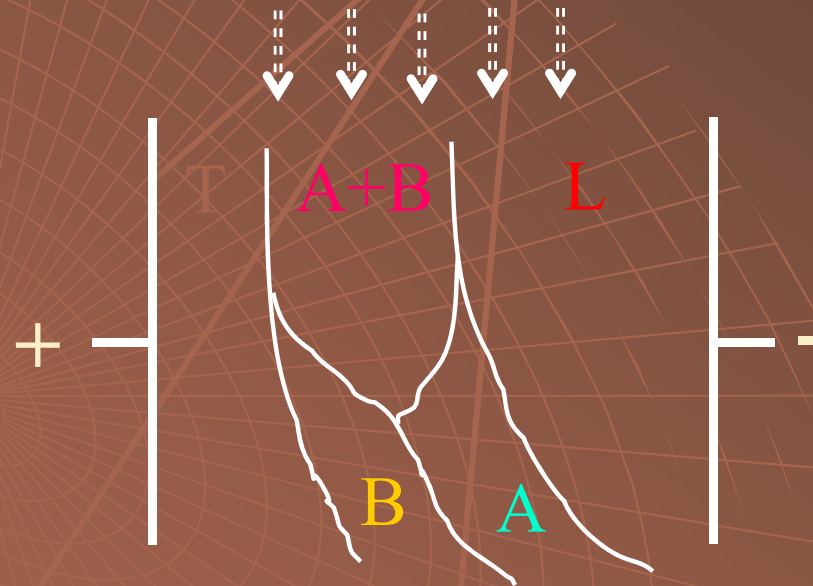

Detekce po elektroforéze a izoelektrické fokusaci

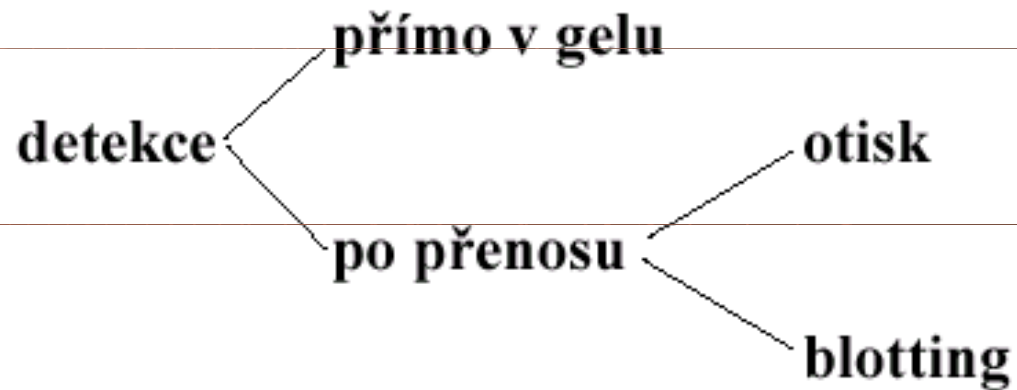

Nespecifická detekce

Reakce s barvičkou

Postup : **A. Fixace**

B. Barvení

C. Odbarvování

Používané barvičky

Amido Black 10 B

Coomassie Brilliant Blue R 250

Coomassie Brilliant Blue G 250

Fast Green

Panceau S

Nespecifická detekce

Barvení Ag

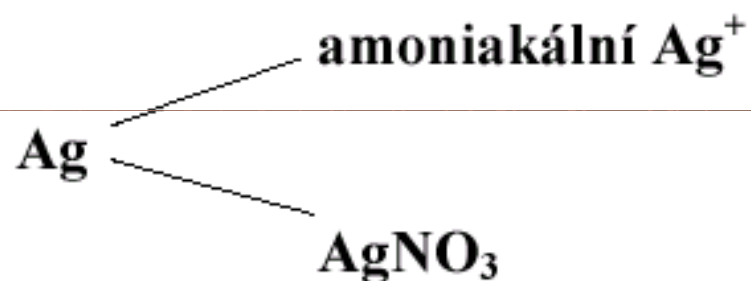

Postup : A. Navázání Ag^+ na bílkovinu
B. Redukce Ag^+ na Ag^0

Nespecifická detekce

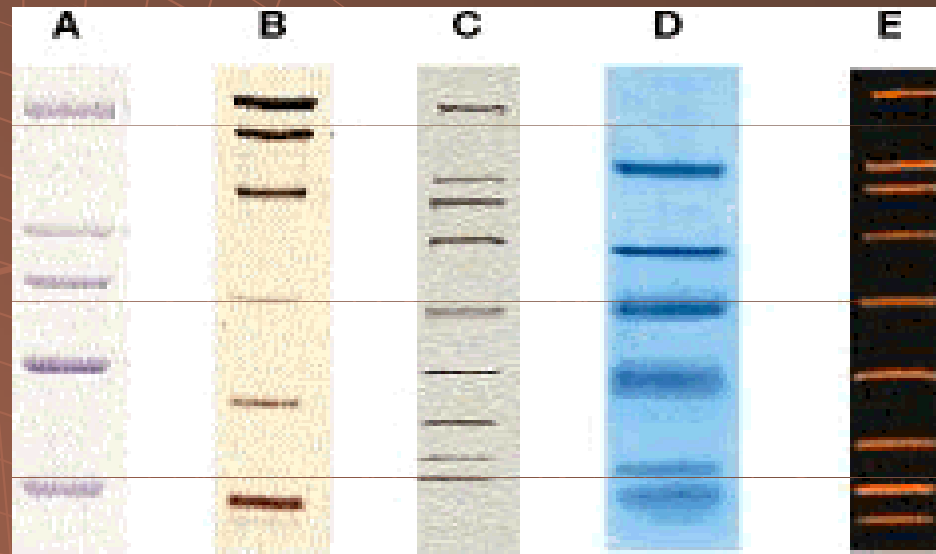

SDS-PAGE Standards provide accurate molecular weight determinations. A. High range SDS-PAGE Standards run on a 7.5% gel and stained with Coomassie blue R-250 dye, B. Low range Silver Stain SDS-PAGE Standards run on a 12% gel and stained with Bio-Rad's Silver Stain Kit, C. Broad range Biotinylated SDS-PAGE standards run on a 4–20% gradient gel, blotted to nitrocellulose, and detected with Avidin-AP. D. Polypeptide SDS-PAGE Standards run on a 16.5% tricine gel and stained with Coomassie blue G-250 dye. E. Broad range SDS-PAGE standards for SYPRO Orange staining run on a 4–20% gel and stained with SYPRO Orange.

Fluorescenční detekce

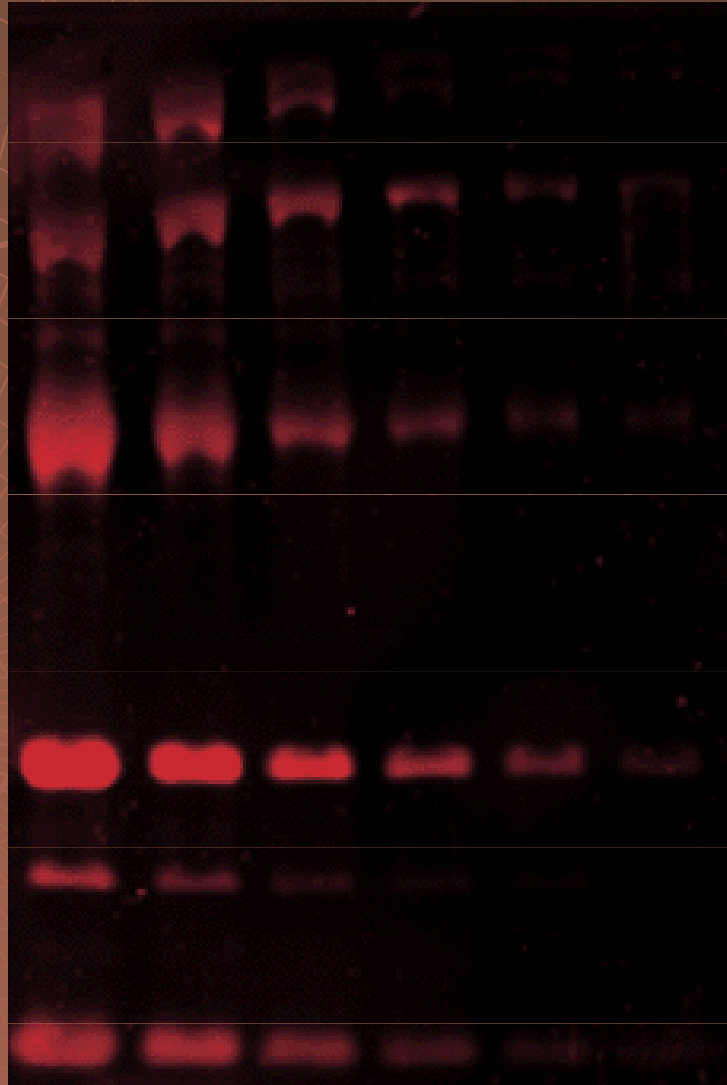

Specifická detekce

Radioaktivní značení

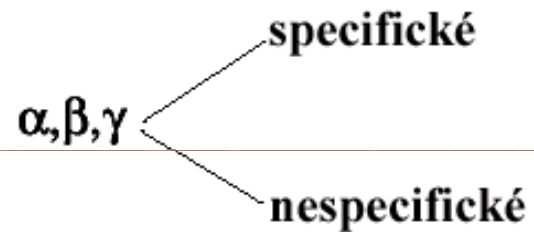

A. Autoradiografie

$^{32}\text{P}, ^{125}\text{I}$

značený protein \longrightarrow rentgenový film

B. Fluorografie

$^3\text{H}, ^{14}\text{C}, ^{35}\text{S}$

značený protein \longrightarrow fluorofor \longrightarrow rentgenový film

Autoradiografie

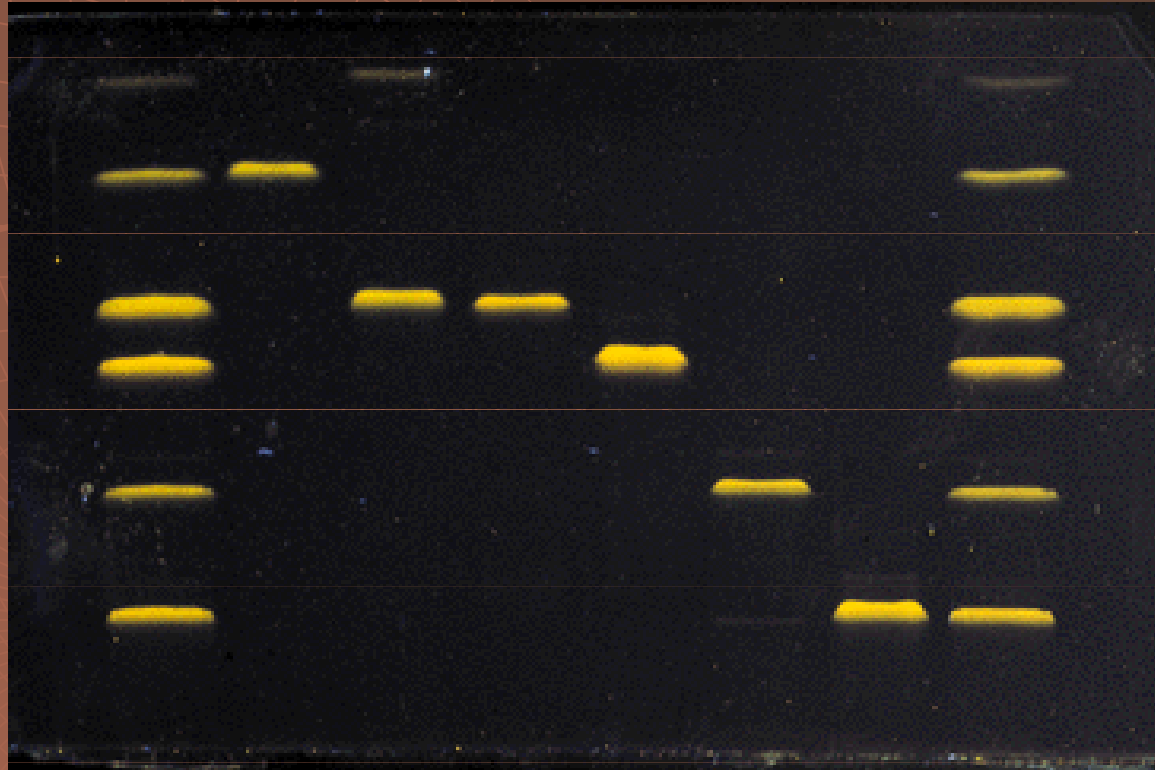

Specifická detekce

Detekce různých skupin bílkovin

glykoproteiny	-	Schiffova reakce (oxidace s HJO_4 , reakce s Schiffovým činidlem - bazický fuchsin)
lipoproteiny	-	Sudan B
hemoproteiny	-	peroxidázová aktivita (hem + benzidin + H_2O_2)
Cu^{2+}	-	alizarin
Fe^{3+}	-	fenantrolin

Detekce glykoproteinů

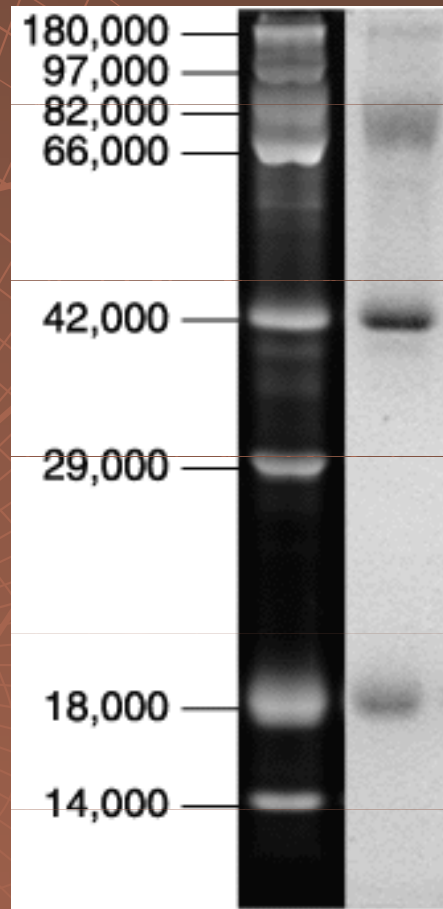

Detekce na základě biologické aktivity

Detekce na základě enzymové aktivity

Rozdělení

A. bezbarvý substrát → barevný produkt

B. barevný substrát → bezbarvý produkt

C. bezbarvý substrát → bezbarvý produkt

→ barevný produkt

D. auxiliární enzymy → barevný produkt

Detekce

- přímo v gelu

- přímo v gelu se zapolymerovanými substráty

- otisk - zymogram

- indikátorové gely

Detekce na základě biologické aktivity

Imunodetekce

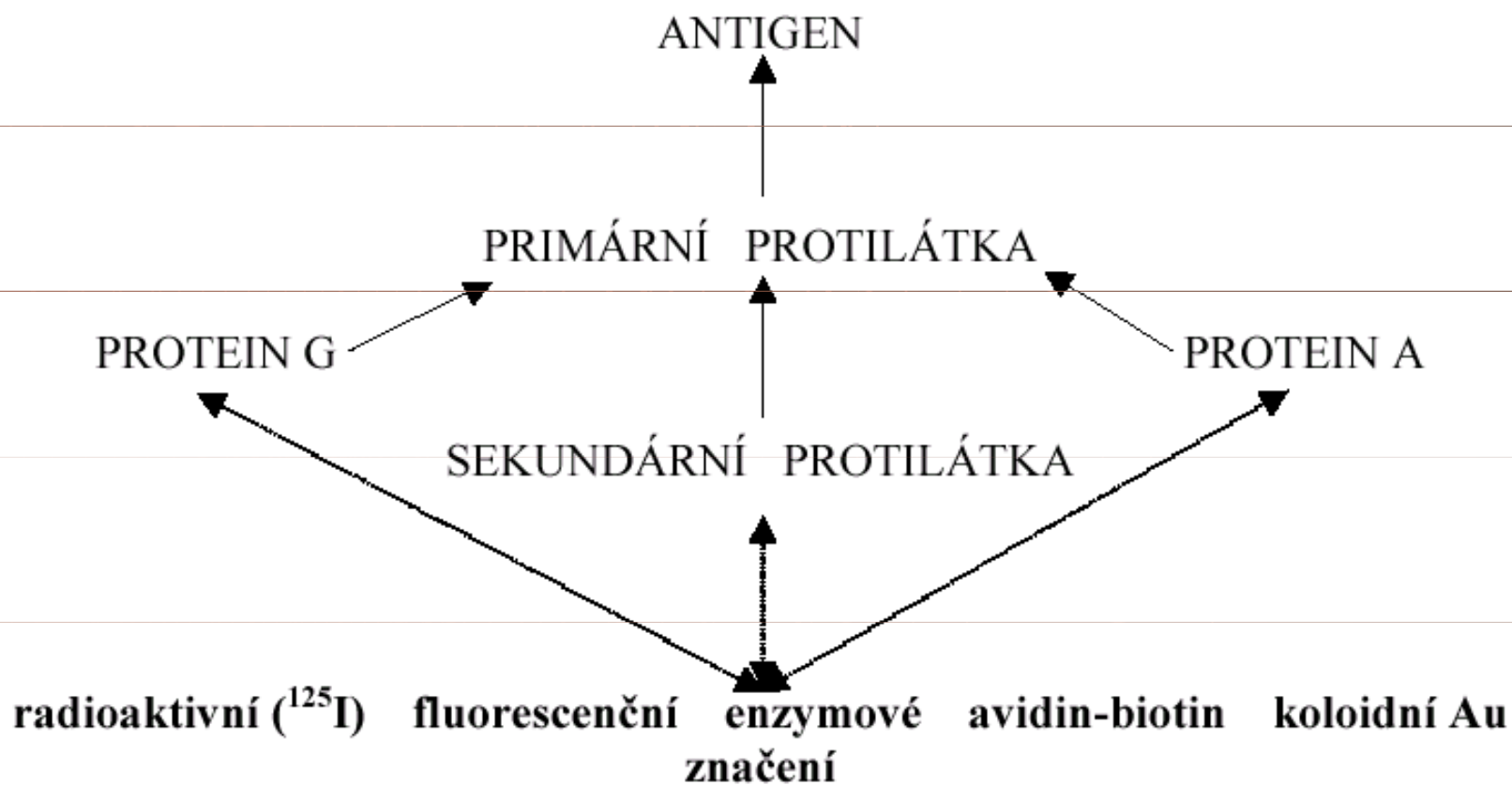

Blotting

- ◆ Southern – DNA
- ◆ Northern – RNA
- ◆ Western – bílkoviny

Blotting

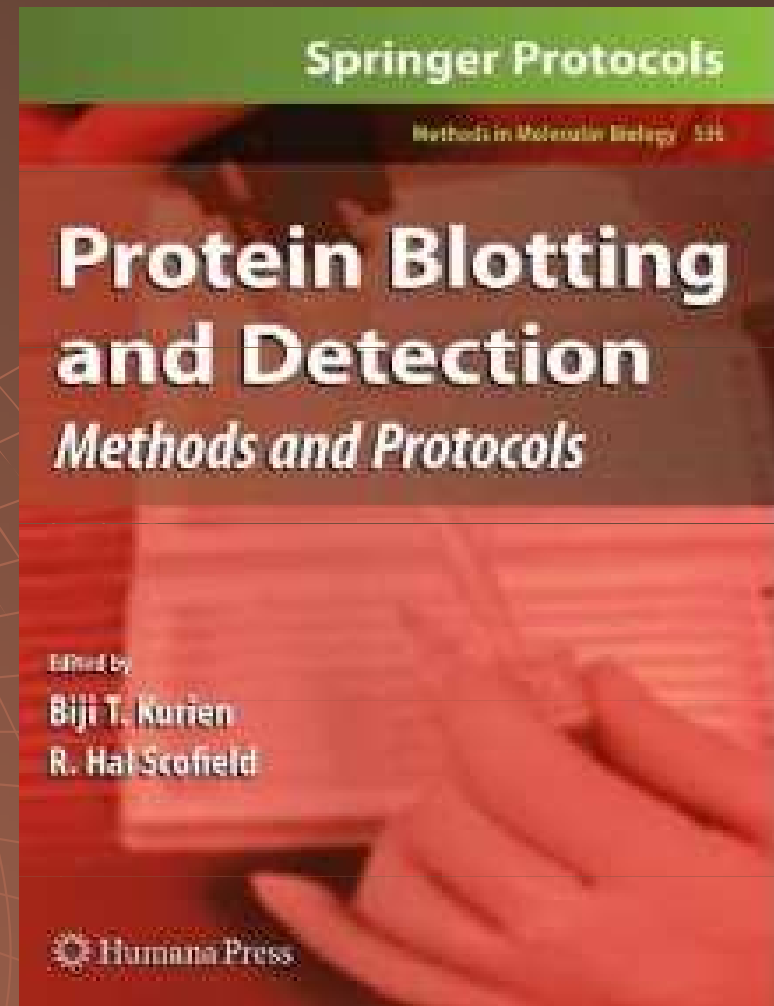
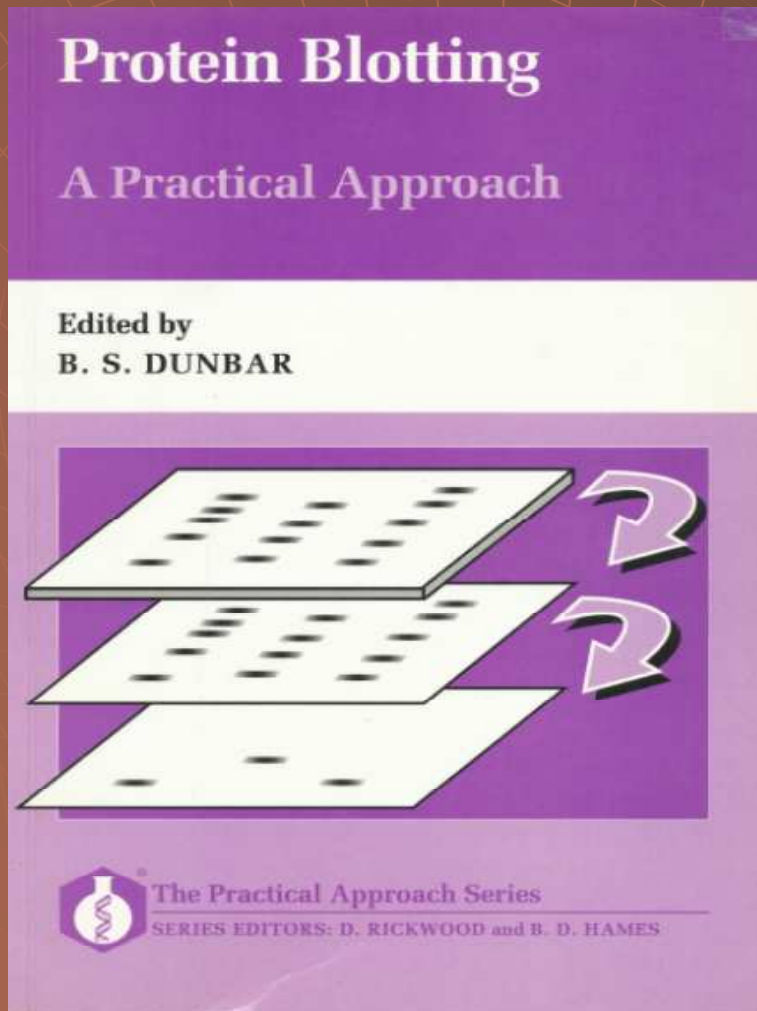

Blotting

Side View:

Before Transfer:

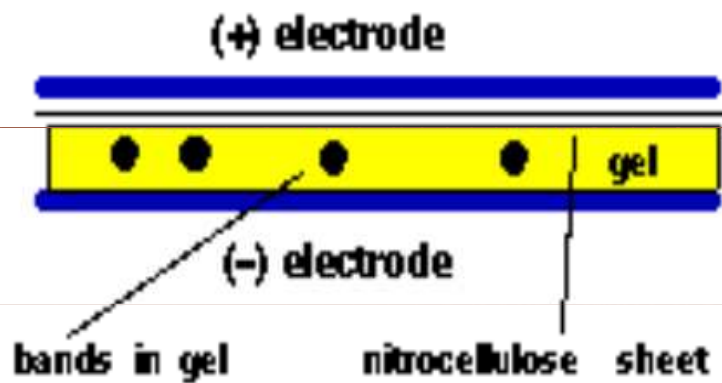

↑
Direction of
Transfer
(electric field)

After Transfer:

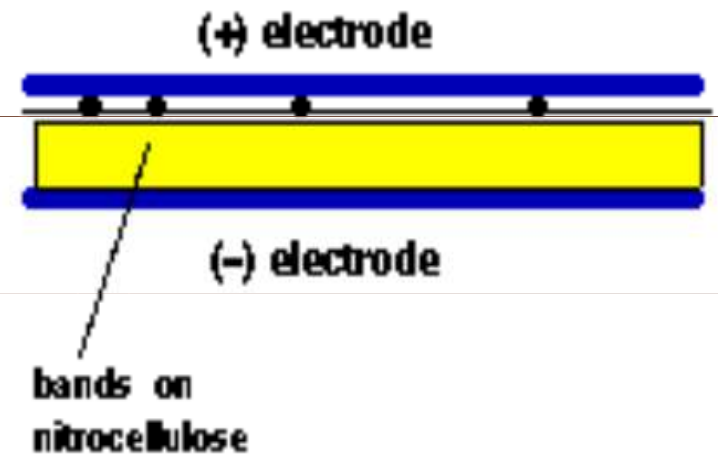

Note: All the layers are pressed tightly together.

Výhody blottingu

- ◆ Dostupnost biomakromolekul
- ◆ Zakoncentrování biomakromolekul
- ◆ Redukce doby a množství potřebných chemikálií
- ◆ Imobilizace biomakromolekul – možnost uchovávání
- ◆ Možnost vícenásobné detekce
- ◆ Mechanická stabilita

Difuzní blotting

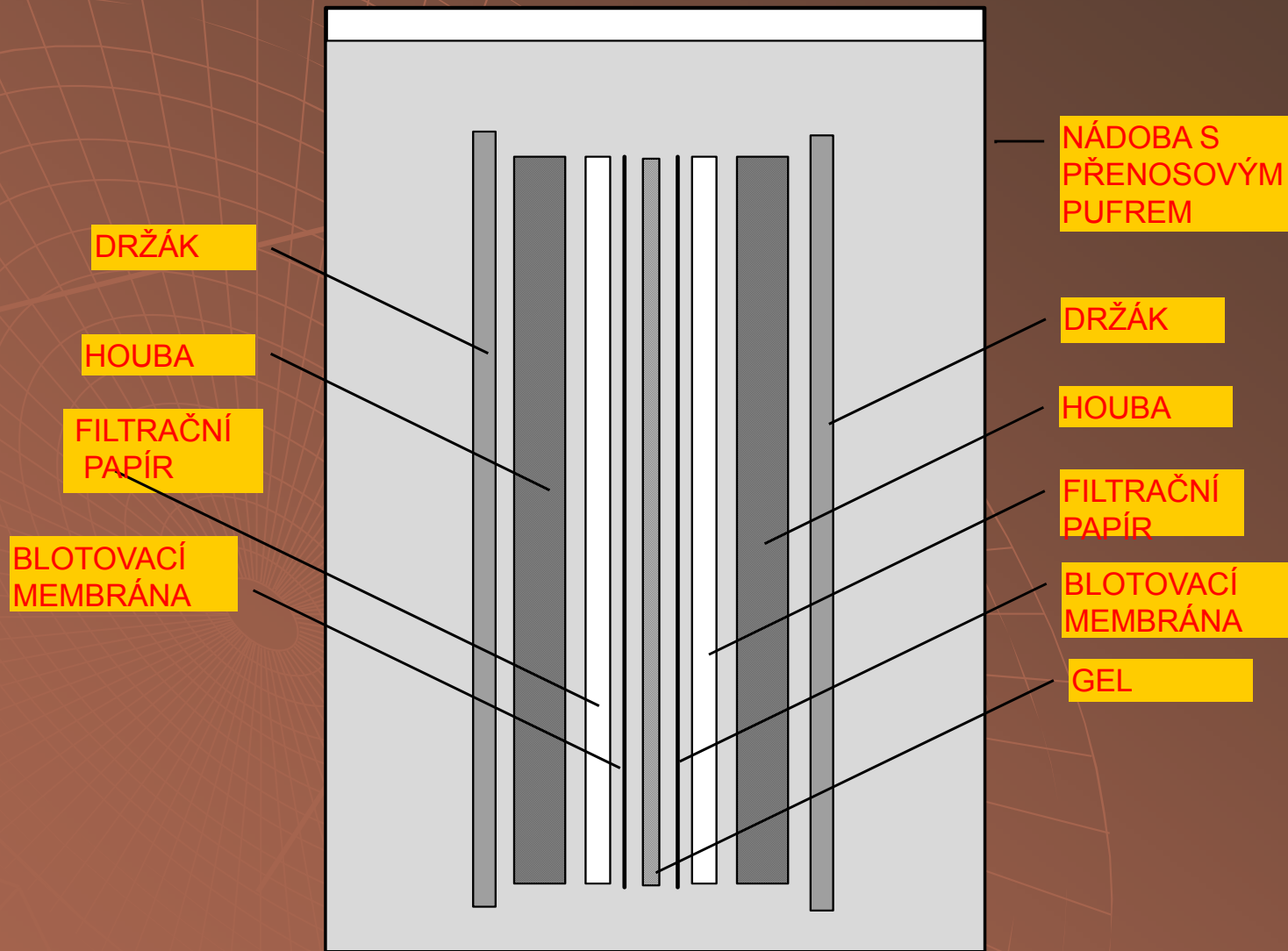

Vakuový blotting

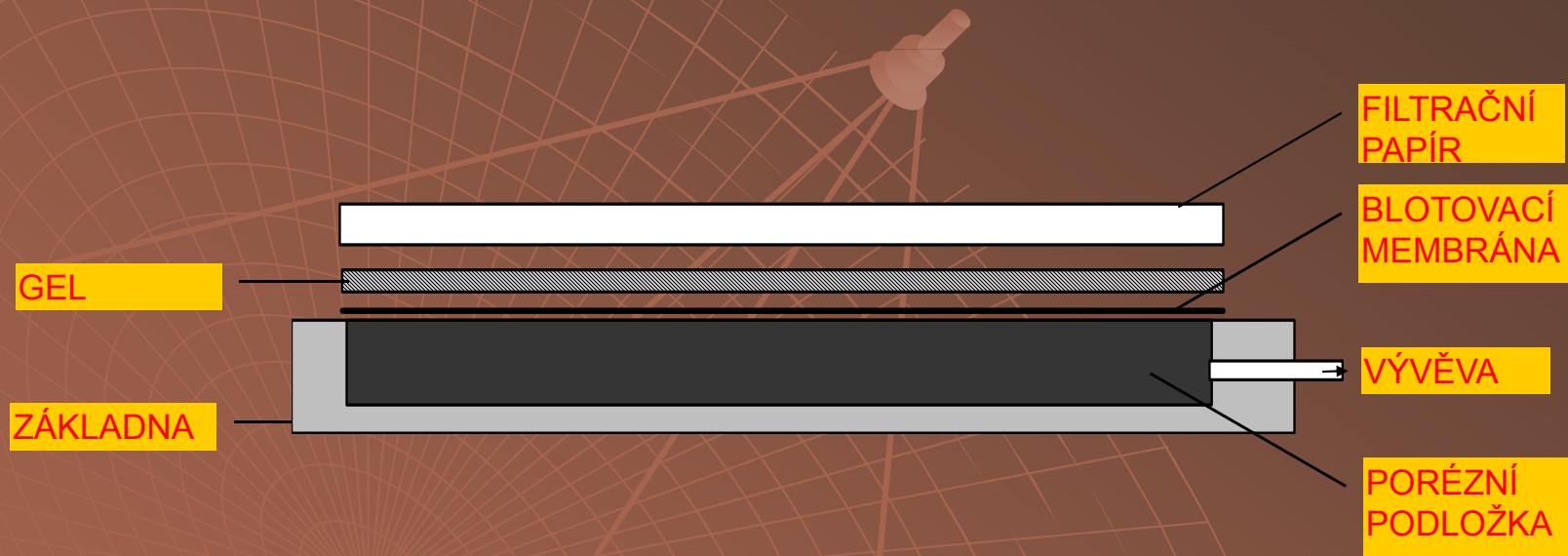

Kapilární blotting

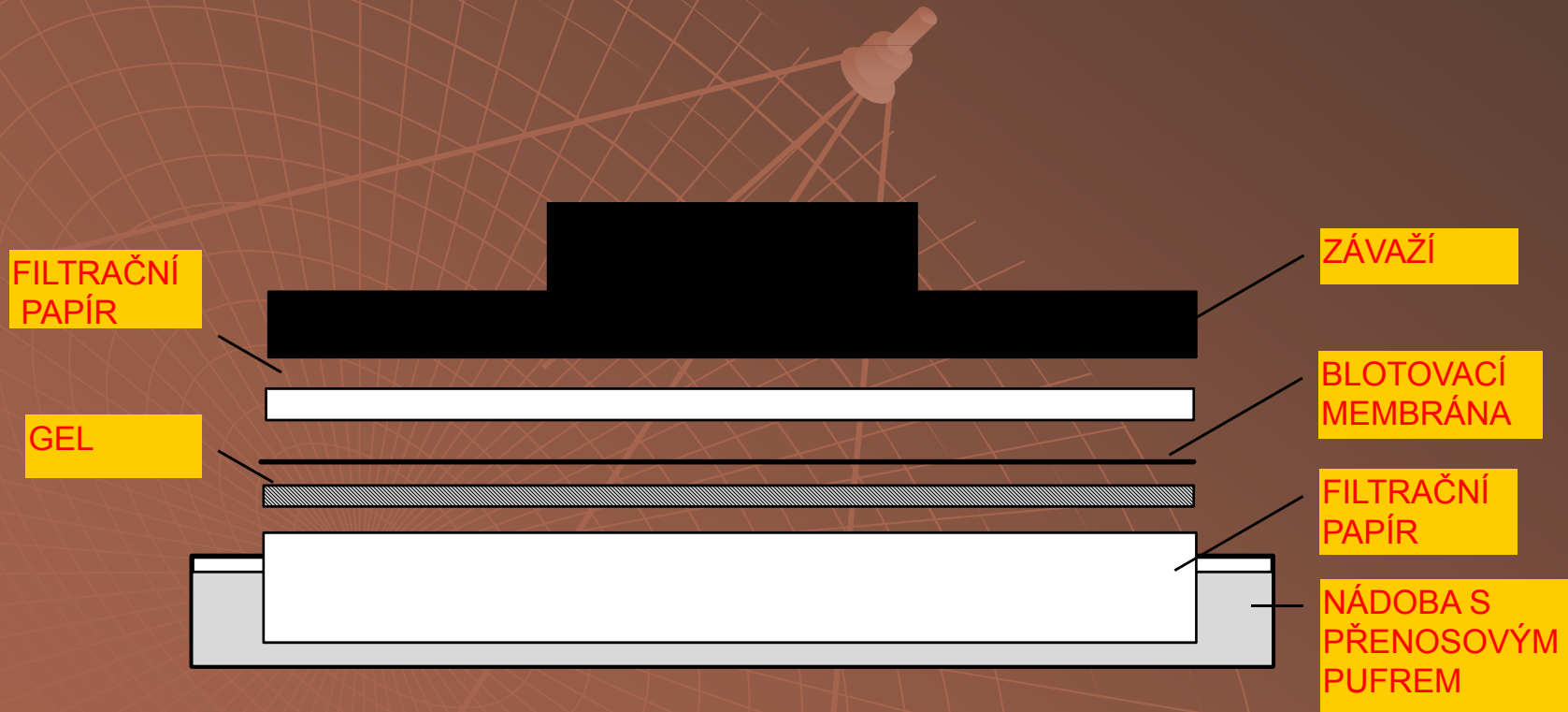

Tankový elektroblotting

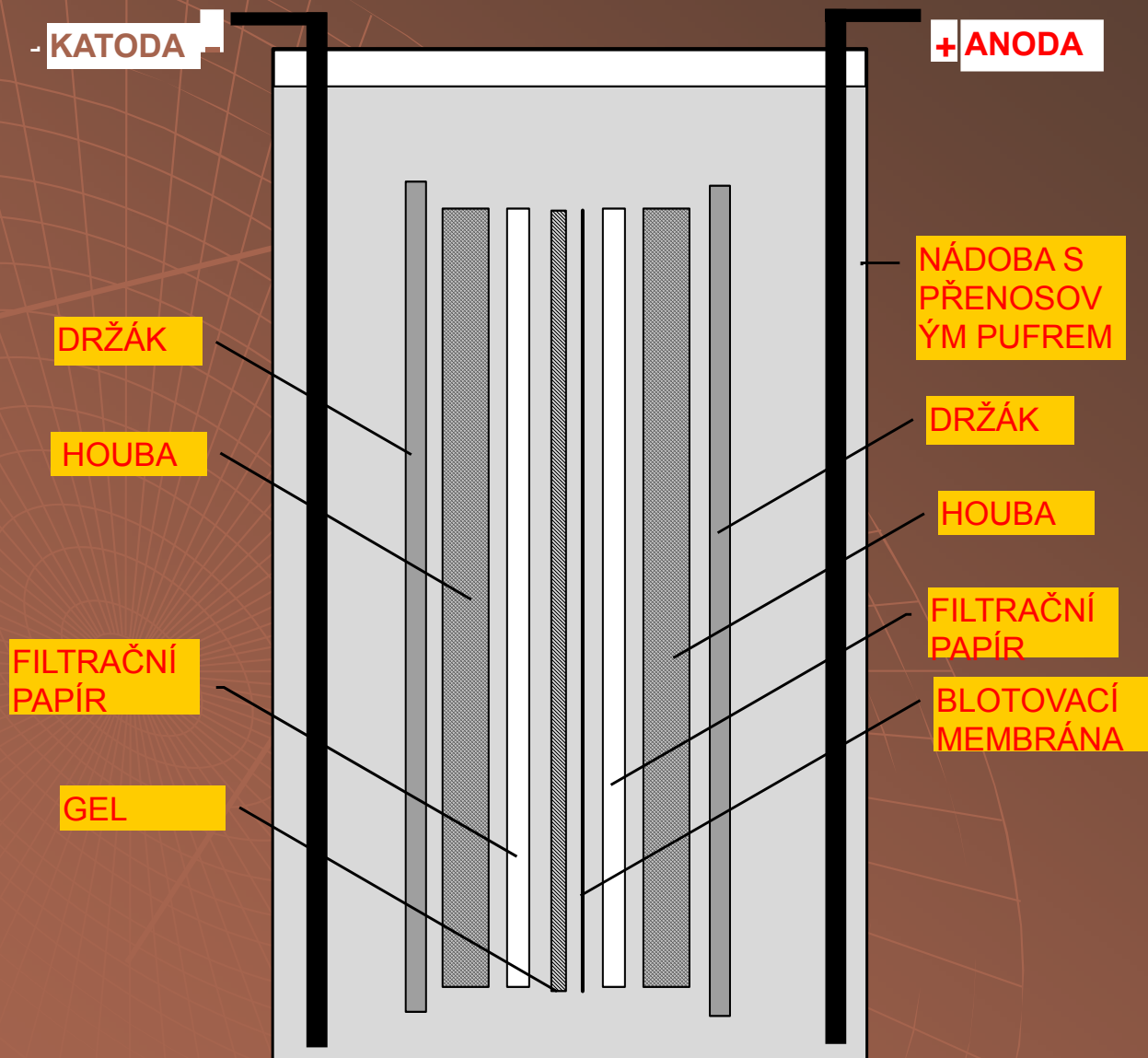

Tankový elektroblotting



Tankový elektroblotting

Mini Protean Trans Blot Cell



„Semi dry“ blotting

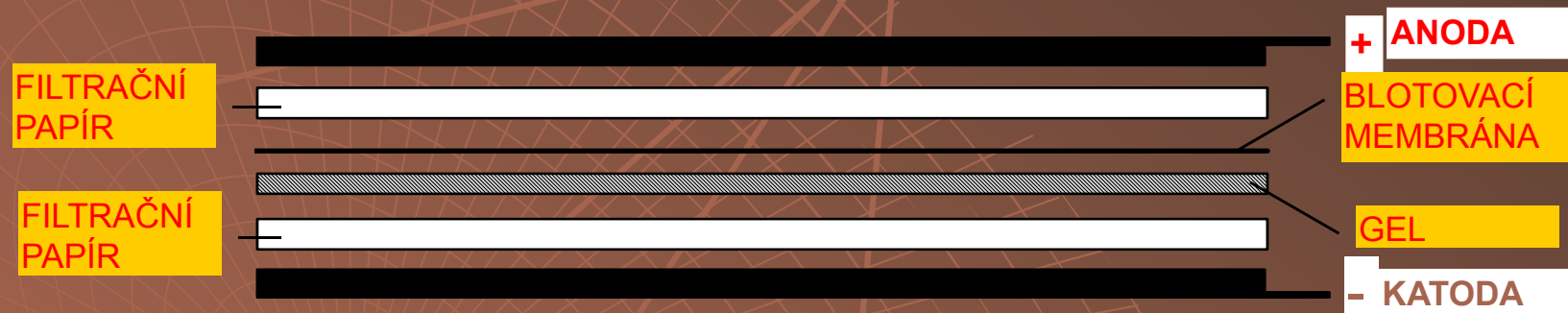

„Semi dry“ blotting



Kapkovací dot blotting

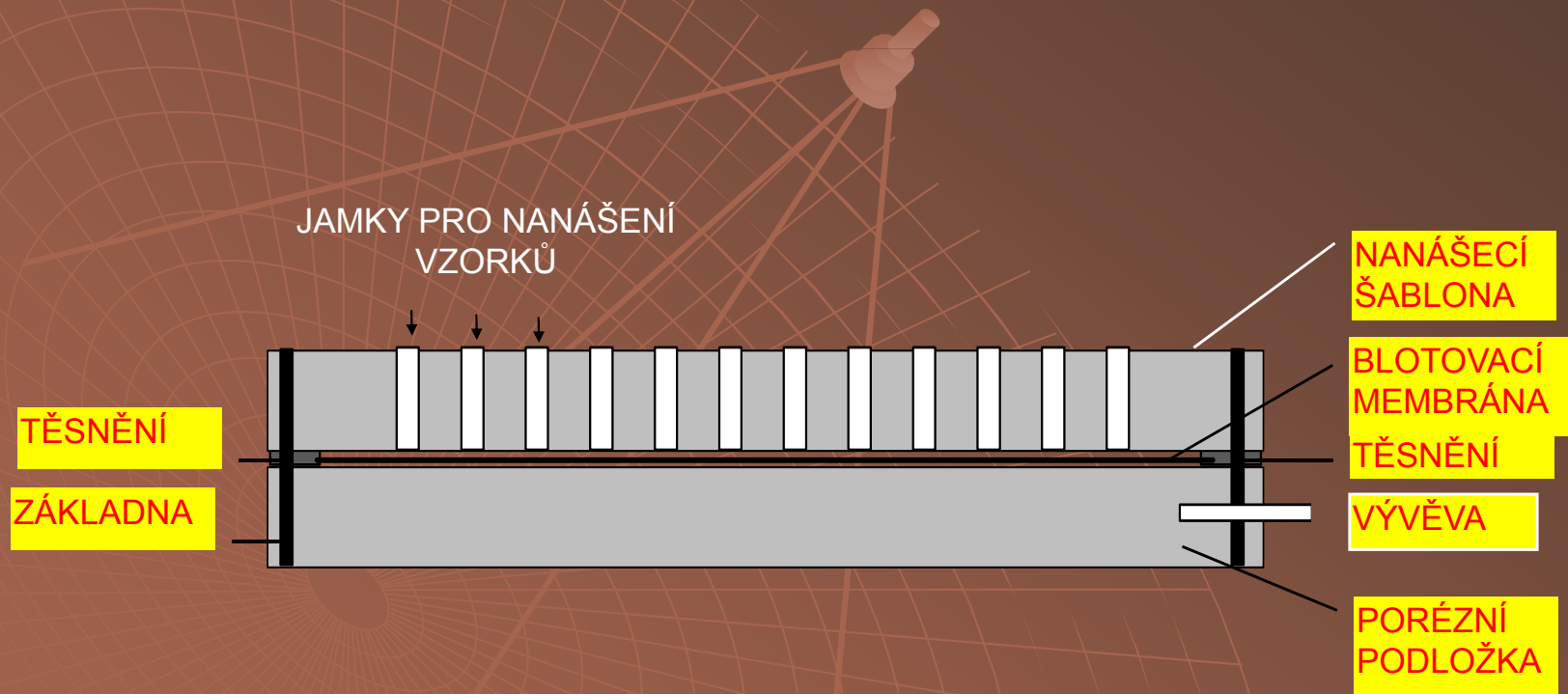

Membrány

- nitrocelulosa - nejběžnější
- polyviniliden difluorid – vysoká vazebná kapacita
- diazobenzoyloxymethyl – chemická aktivace
- ionexové membrány - preparativní
- aktivovaná skleněná vlákna – pro přímou sekvenaci

Detekce

HYBRIDIZACE

- radioaktivní proba – vysoká senzitivita, Southern blot
- neradioaktivní proba – biotin – streptavidin, dioxigenin

REAKCE SE SUBSTRÁTEM nativní enzym, nedifundující substrát

“IMUNOBLOTTING“

^{125}I -protein A

enzymem značená sekundární protilátka – konjugace s peroxidasou (tetrazoliová sůl), alkalickou fosfatasou

zlatem značená sekundární protilátka (100 pg)

chemiluminiscence – nejcitlivější

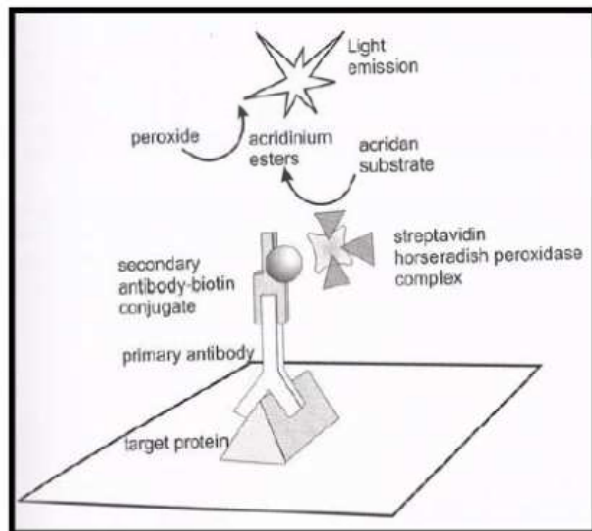

Detekce

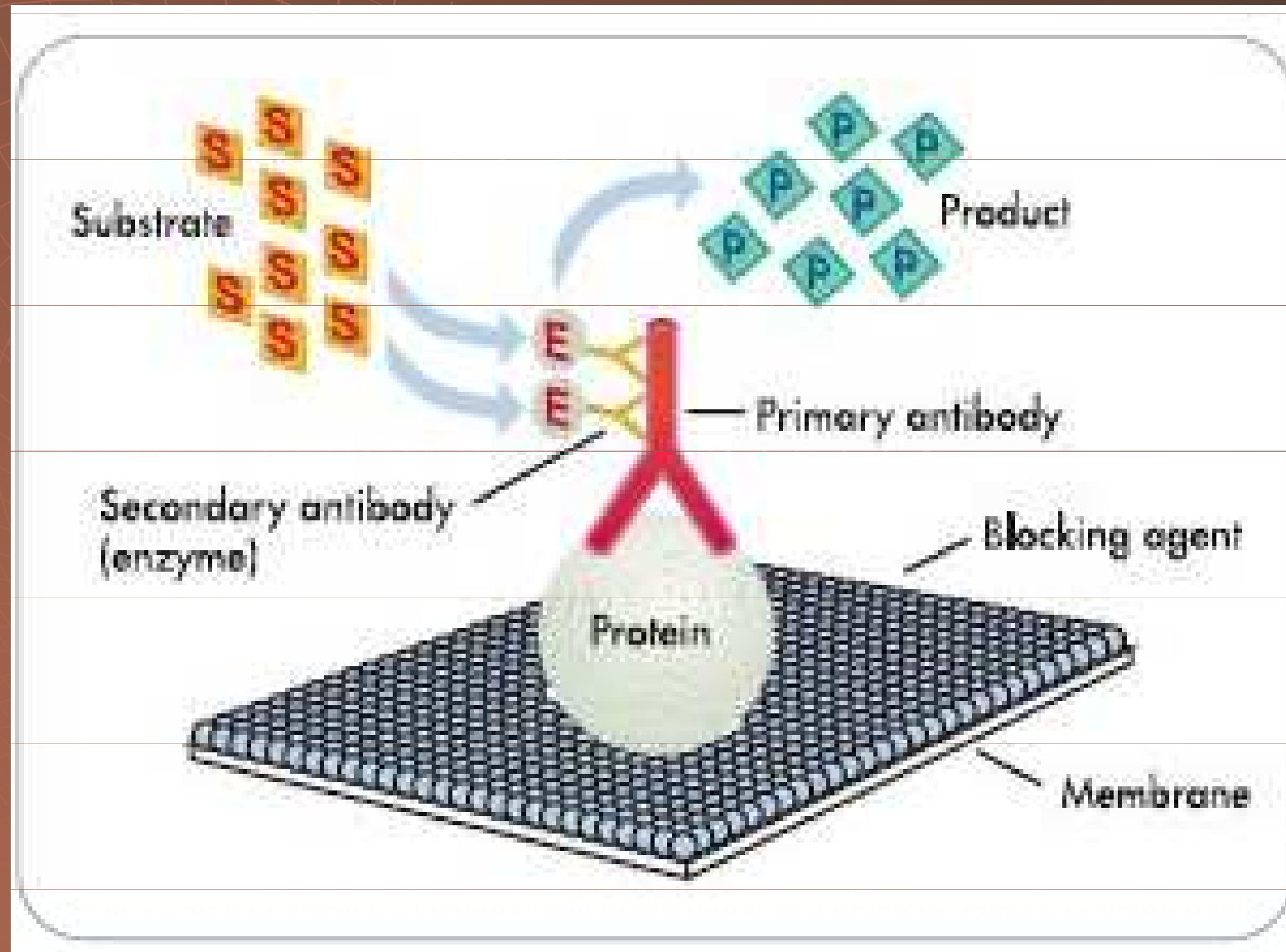

Detekce

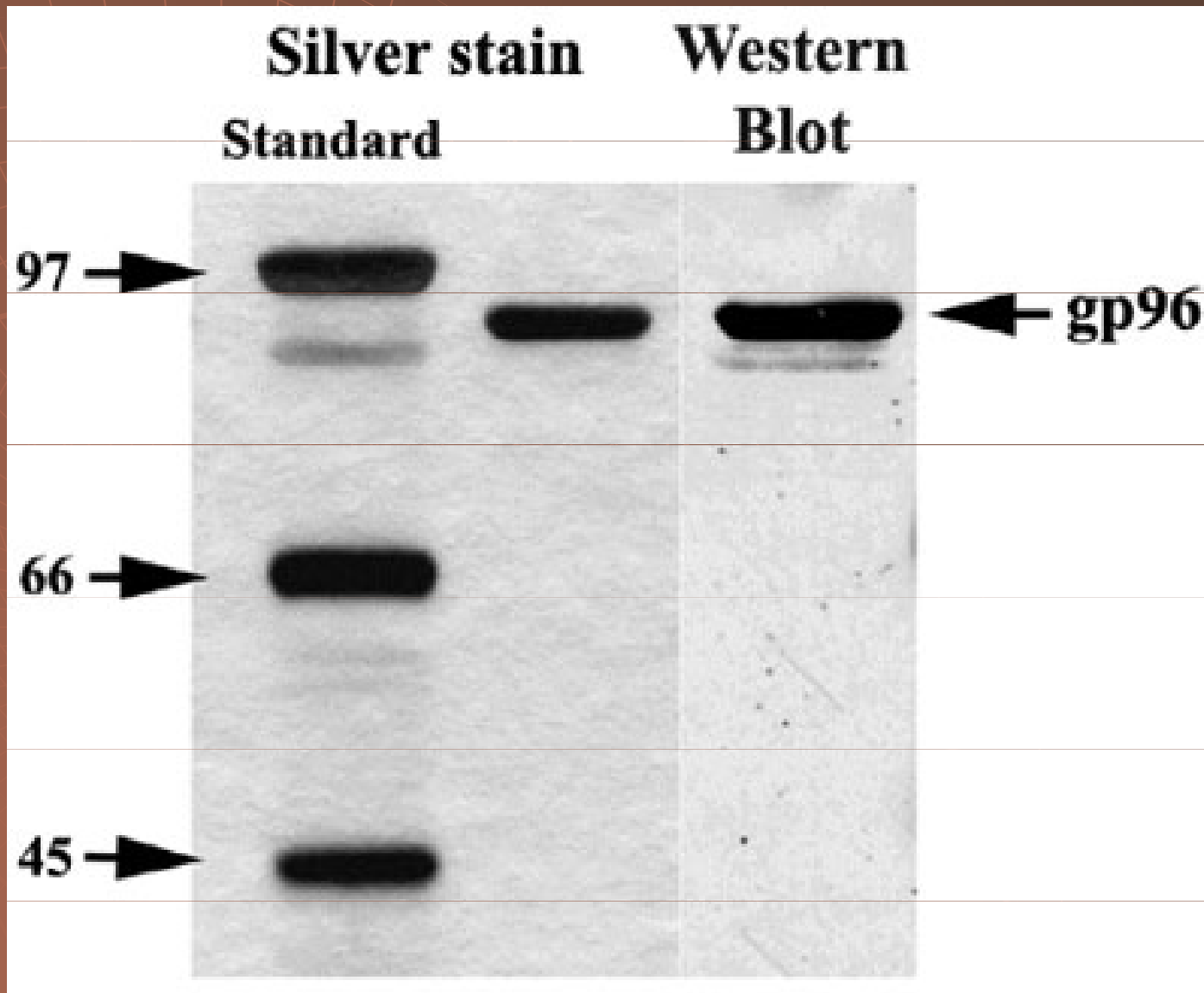

Speciální aplikace blottingu

- ◆ Získání homogenních preparátů
- ◆ Studium složení a struktury bílkovin
- ◆ MS bílkovin – MALDI, DESI
- ◆ Příprava protilátek
- ◆ Purifikace protilátek

Detekce

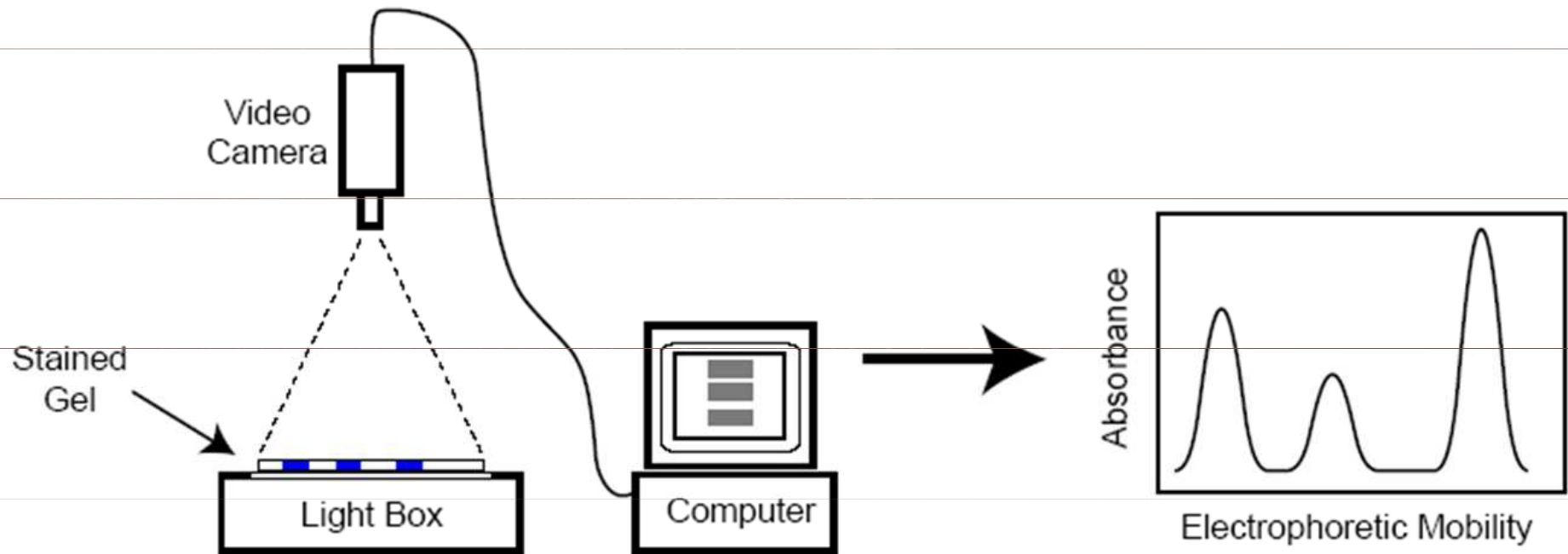

Detekce

