

Vývin zobrazovania priestoru dejinách maliarstva od renesancie po kubizmus

Giotto di Bondone (1266-1337)

Zjavenie bratovi Augustínovi a biskupovi (okolo 1325)



Giotto di Bondone (1266-1337)

Oplakávanie Krista (1306)



Lorenzetti (1285-1348) *Zvestovanie* (1344)

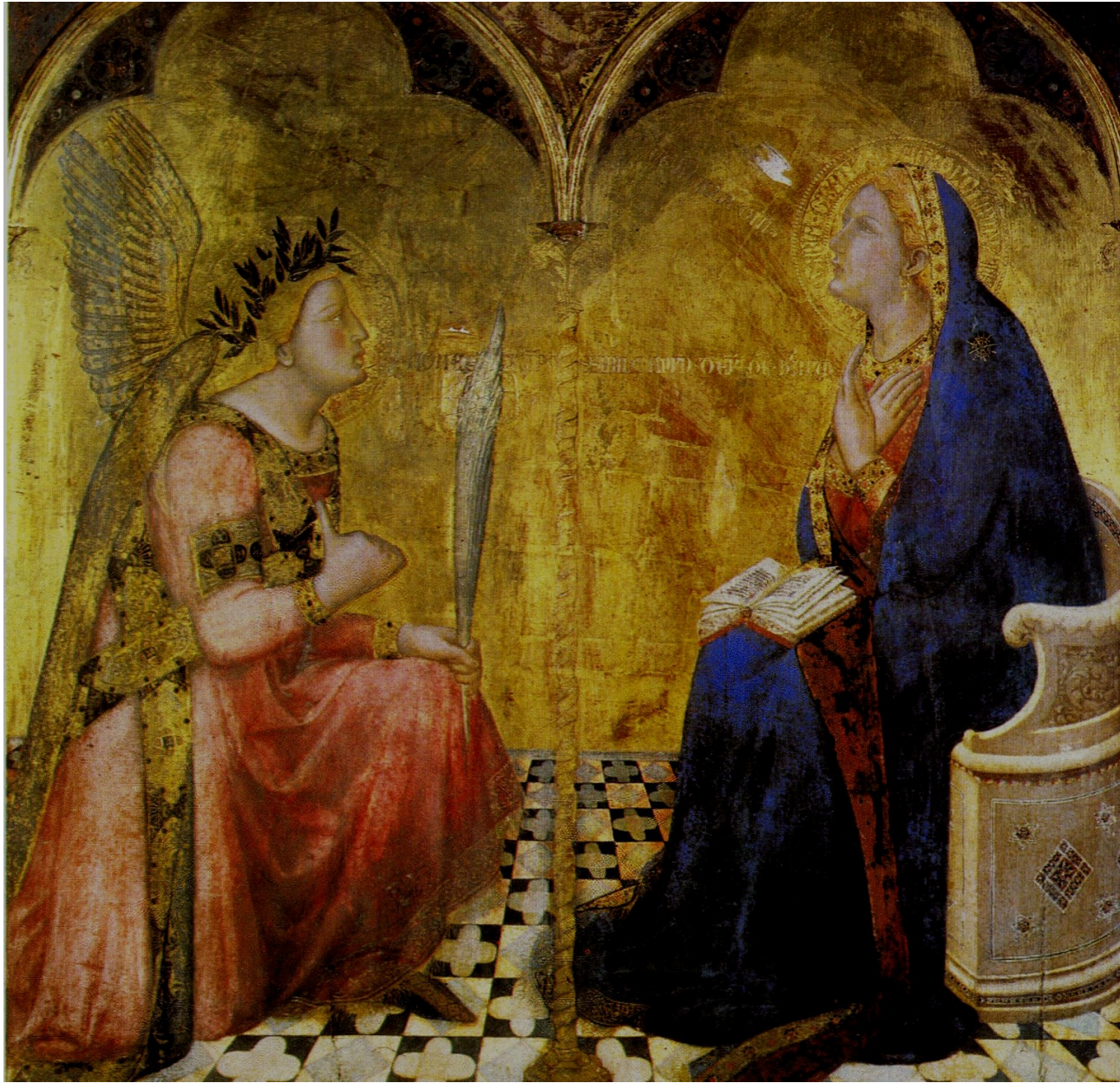



Guidi Tommaso
Masaccio (1401-1428)

Svätá Trojica (1425)

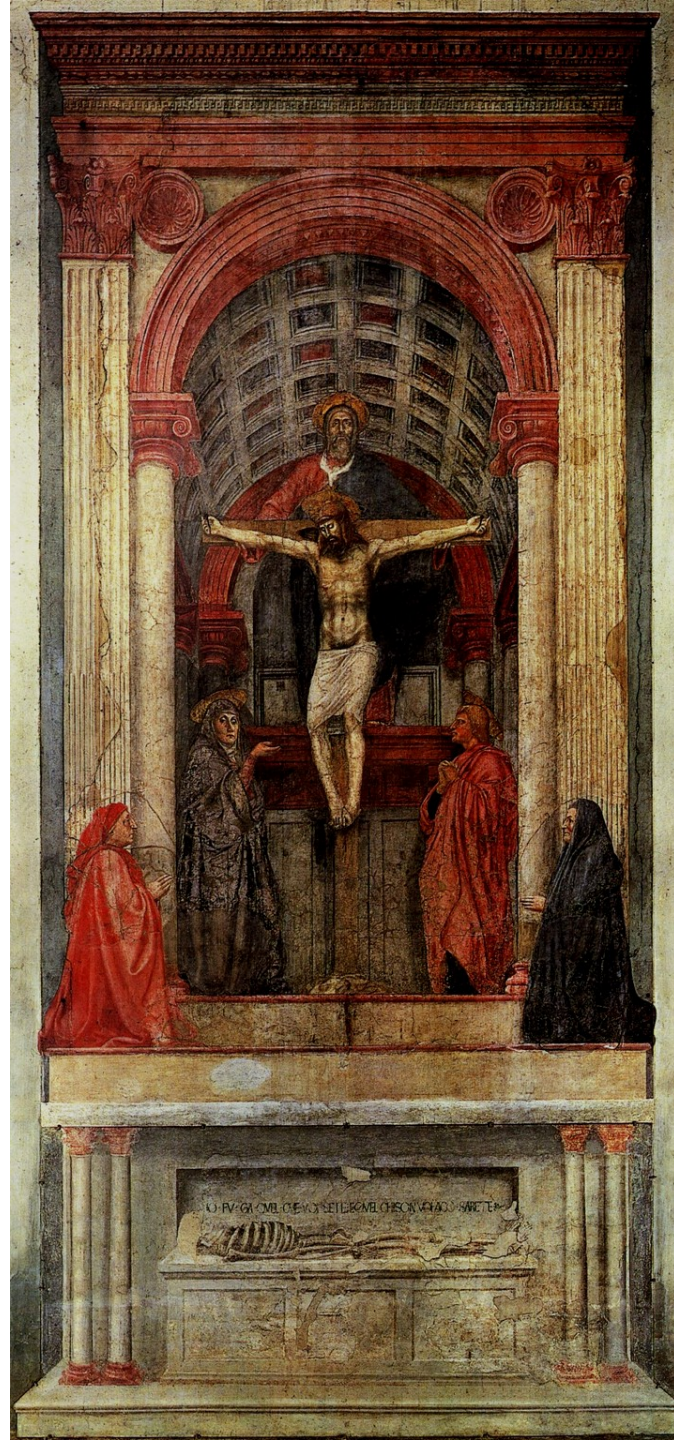

Guidi Tommaso
Masaccio (1401-1428)

Vyhnanie z raja (1426)

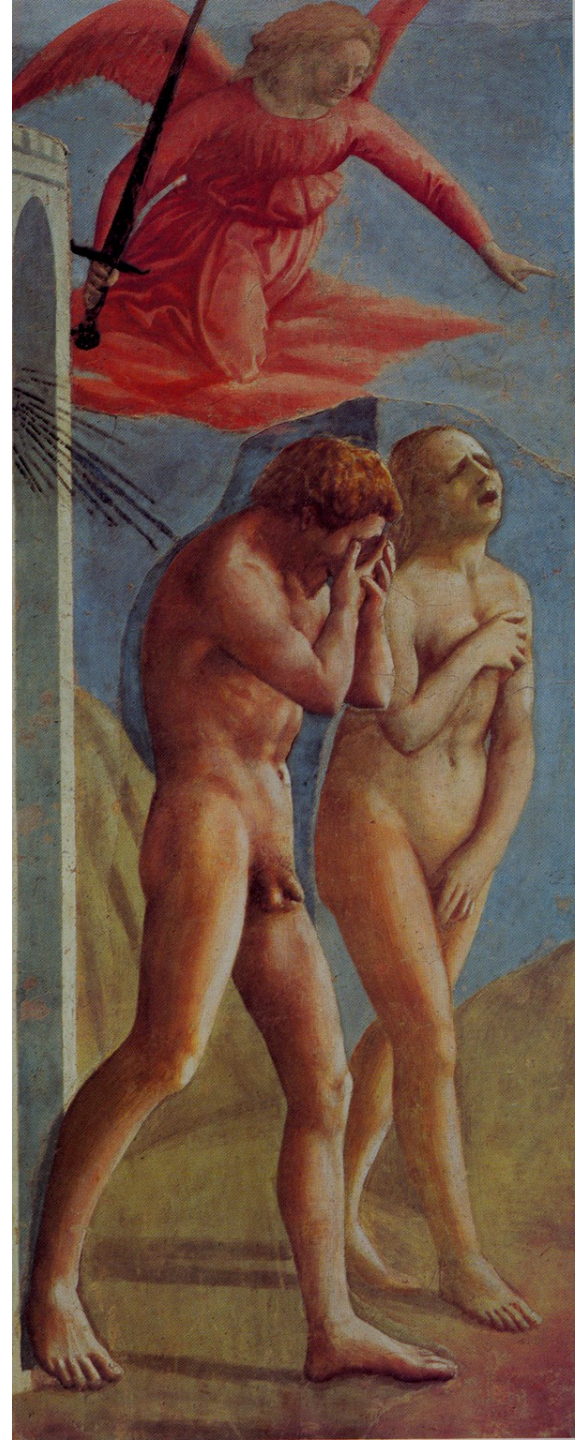

Paolo Ucello
(1397-1475)

*Náhrobok Sira
Johna Hawkwooda*
(1436)



Leonardo da Vinci

(1452-1519)

Mona Lisa

(1505)

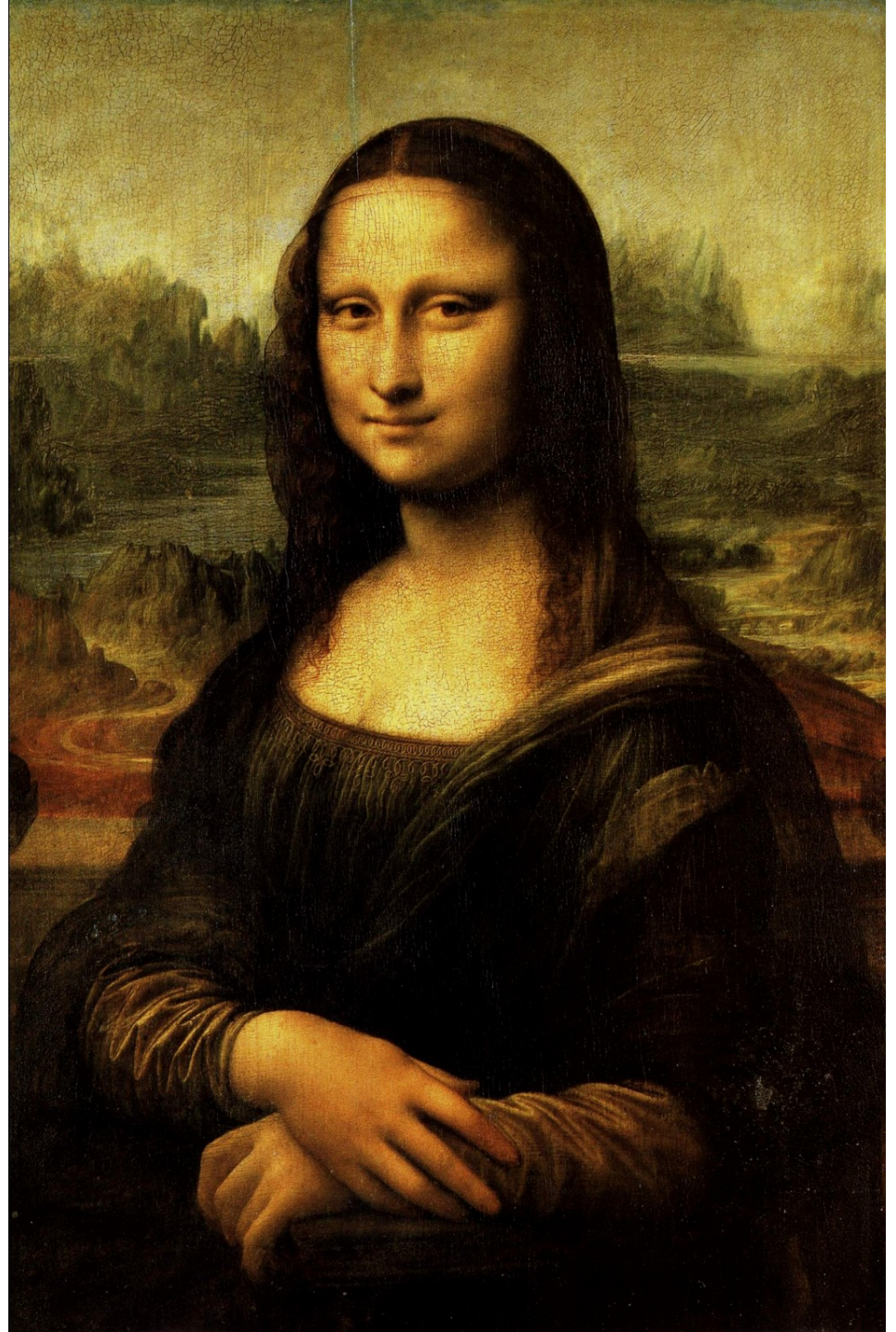

Leonardo da Vinci (1452-1519)

Posledná večera (1497)

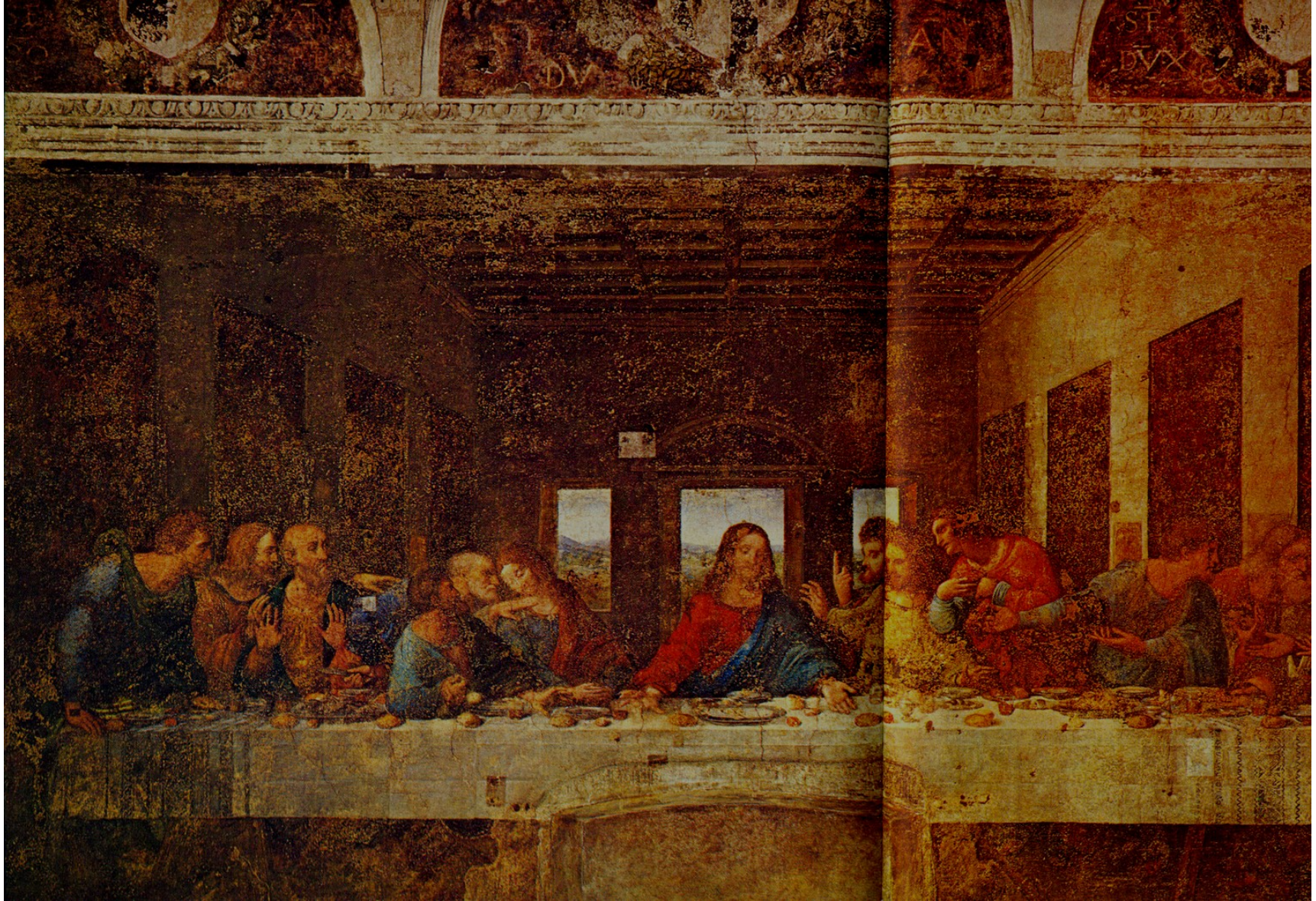

Leon Battista Alberti (1404 - 1472)

De Pictura vydaná r. 1435

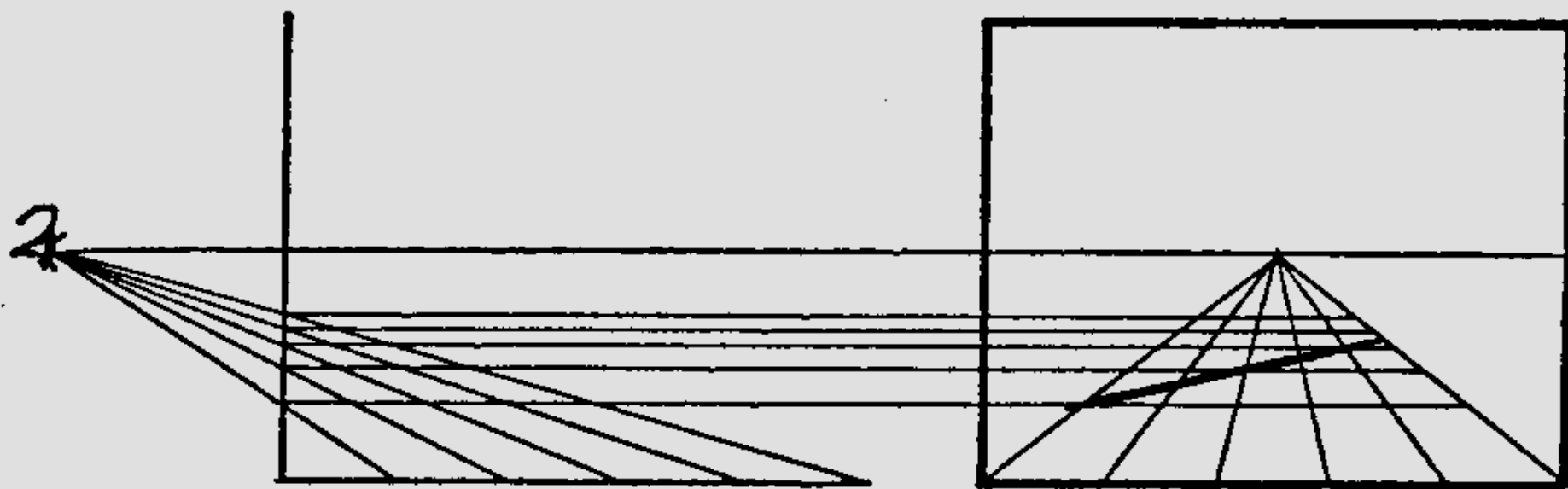

Albrecht Dürer (1471 - 1528)

*Underweysung der messung mit dem zirckel
vn richt sचेyt vydaná r. 1525*



Gérard Desargues (1591 - 1661)

- nahradenie predmetu jeho obrazom
- reprezentácia reprezentácie
- zabudovanie hľadiska do obrazu

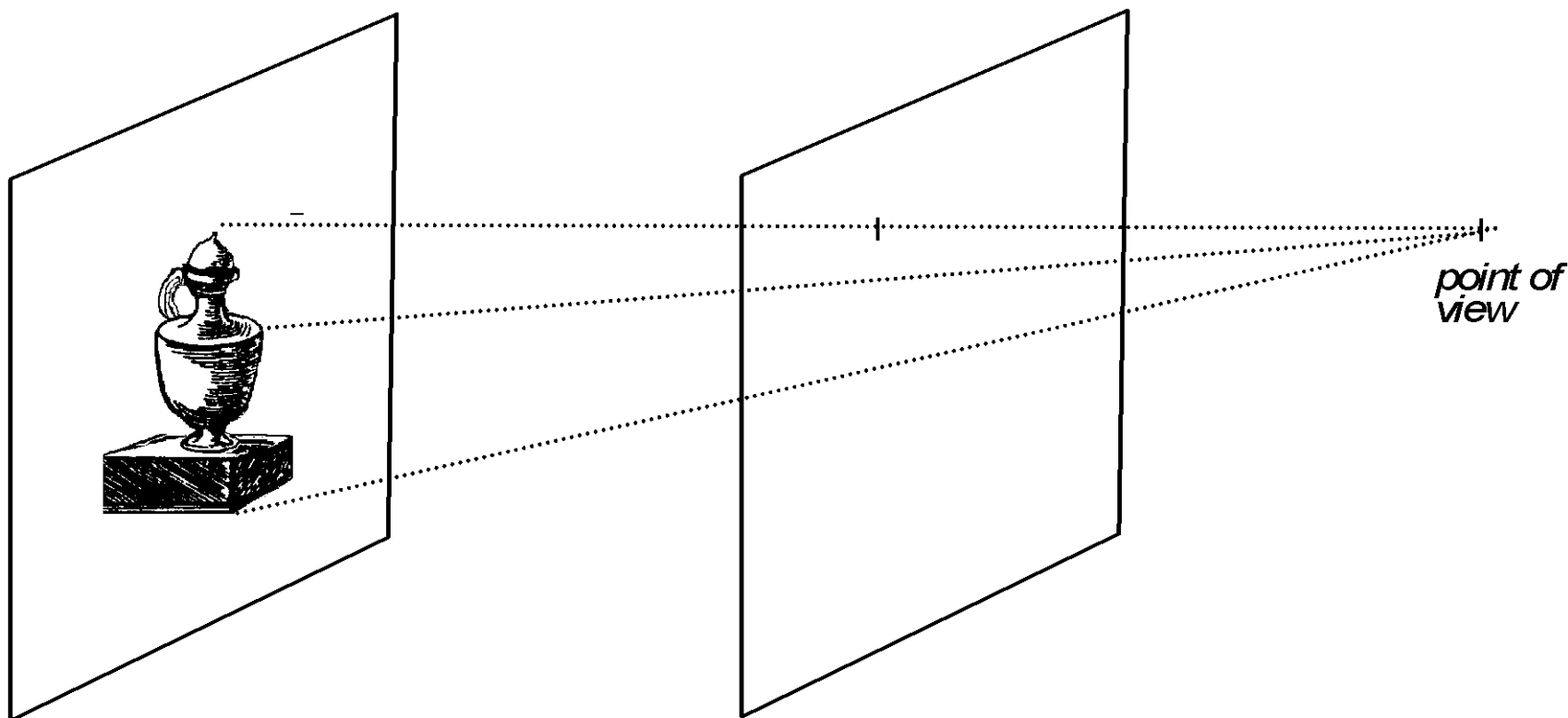

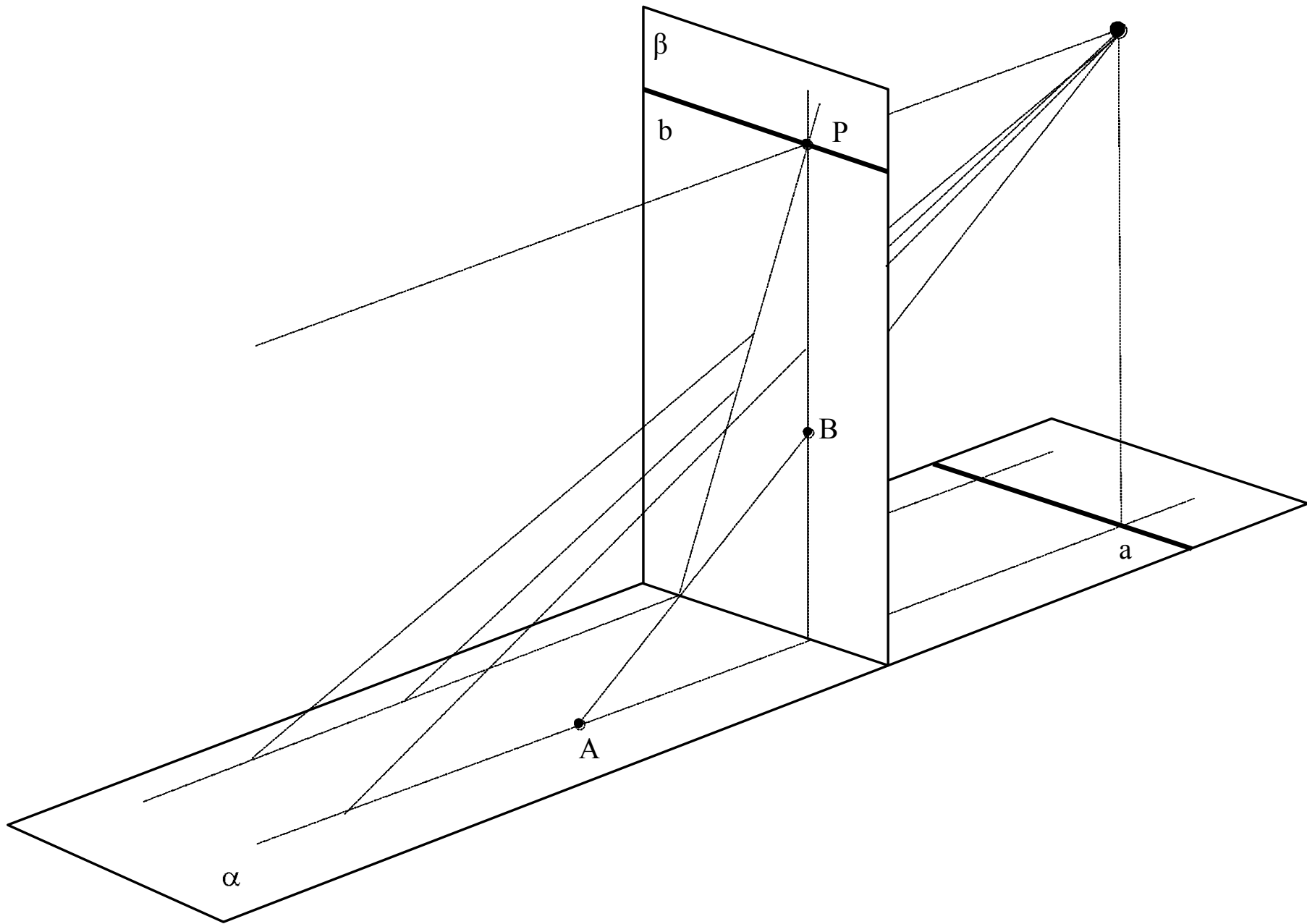

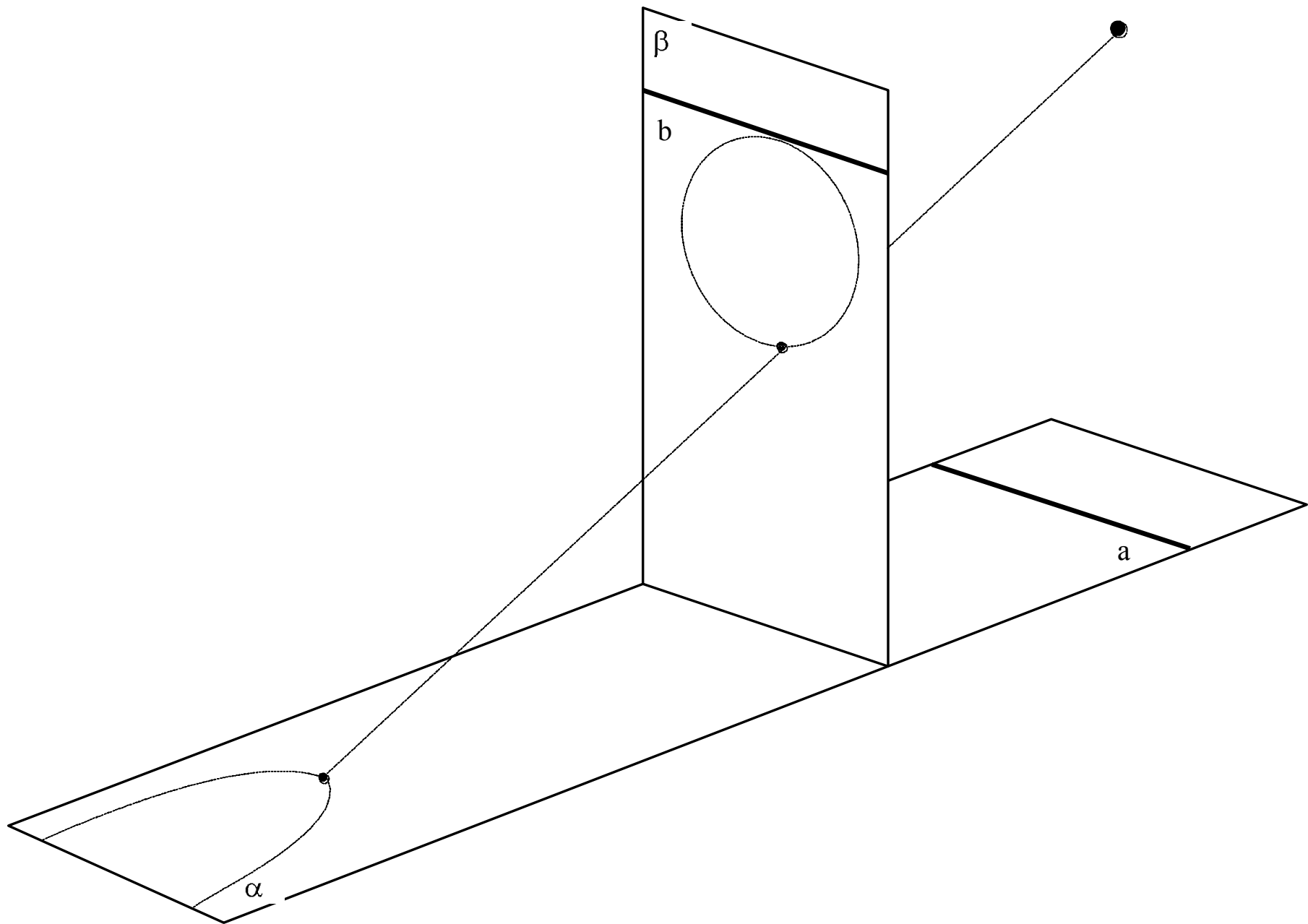

Hans Holbein
(1498 - 1543)

Vyslanci
(1533)



(lebka)



Domenico
Theotokopoulos

(1541-1614),

El Greco

Ján Krstiteľ
(okolo 1600)



Caravaggio (1573 - 1610)
Dávid s hlavou Goliáša (1607)



Diego Velázquez

(1599-1660)

Infantka Margarita

(1653)



Rembrandt

(1606-1669)

Mladá žena
kúpajúca sa v
potoku (1655)



Rembrandt
(1606-1669)

Portrét Agathy
Basovej (1641)



Andrea Pozzo
(1642-1709)

*Apoteóza
Svätého Ignáca
(1694)*



Andrea Pozzo
(1642-1709)

*Perspectivae
Pictorum atque
Architectorum,*
vydané r. 1693

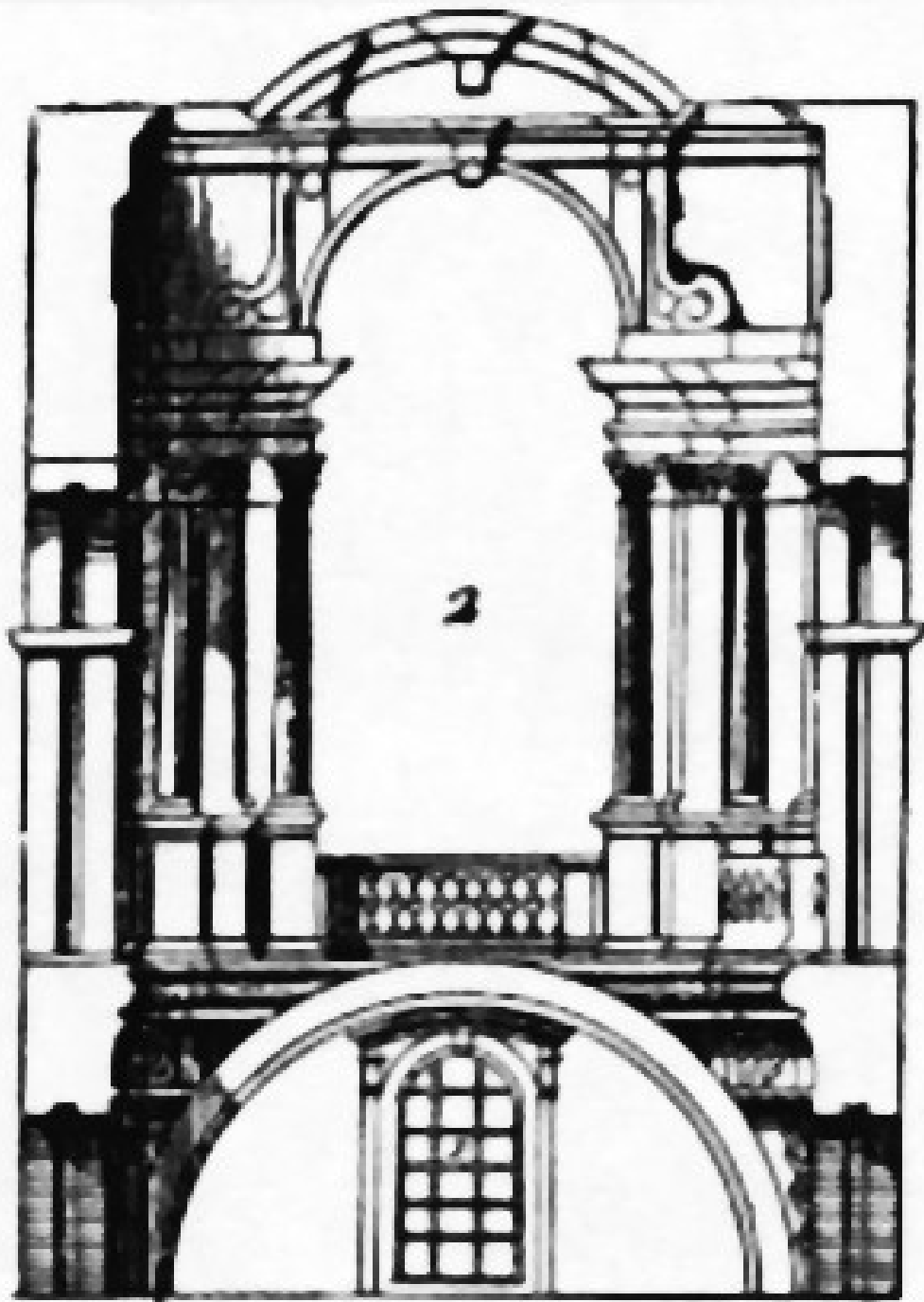

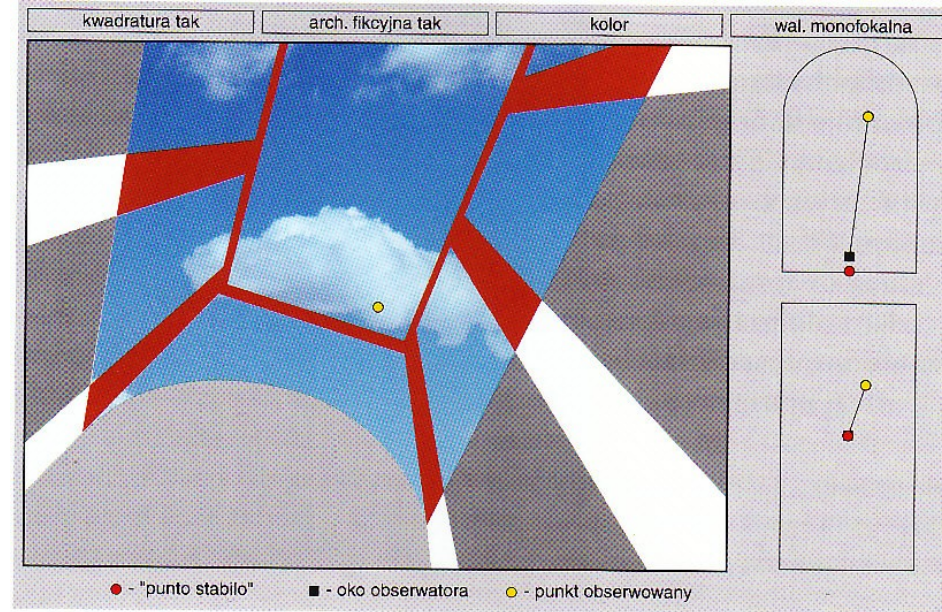

Il. 6. Architektura fikcyjna i kwadratura oglądane z punto stabile.

Jeżeli staniemy poza *punto stabile*, zauważymy, że przez szl nie widzimy obraz fikcyjnej kondygnacji całkowicie odmienny namalowanego na sklepieniu (il. 7).

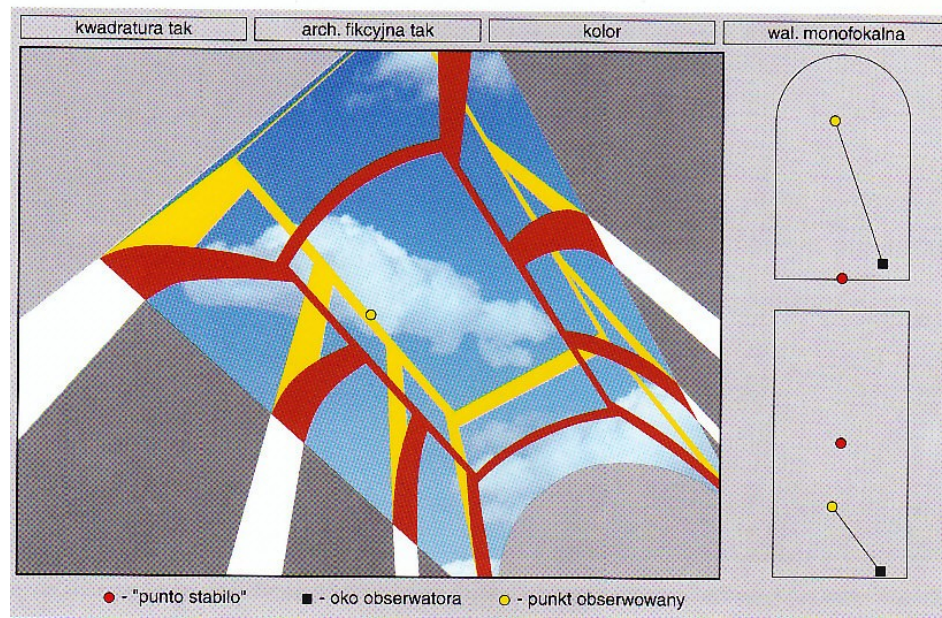

Nikolaj Ivanovič Lobačevskij
(1793 - 1856)

$$a^2 = b^2 + c^2 - 2bc \cdot \cos \alpha$$

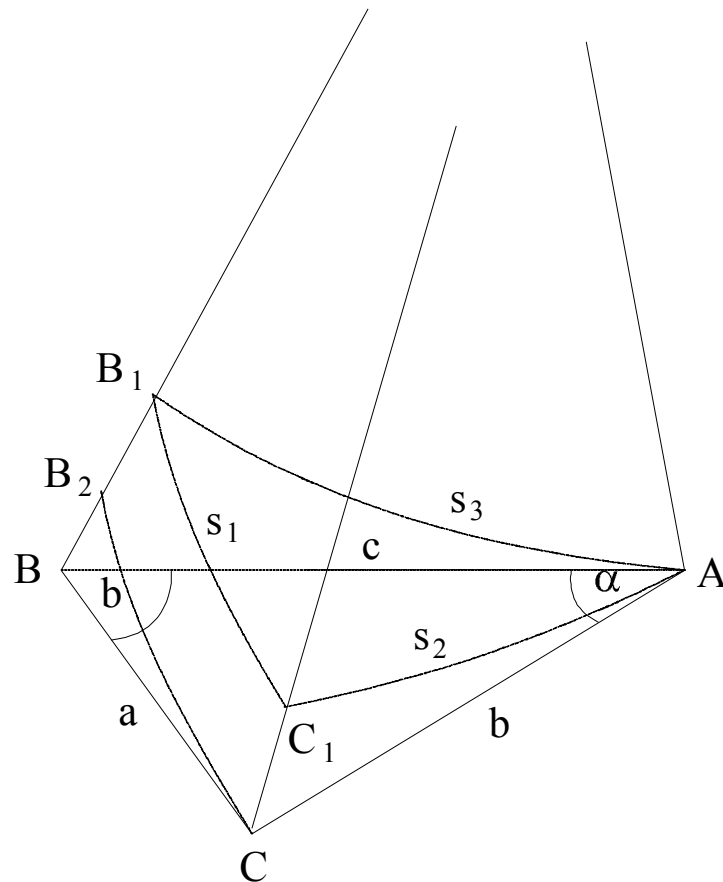

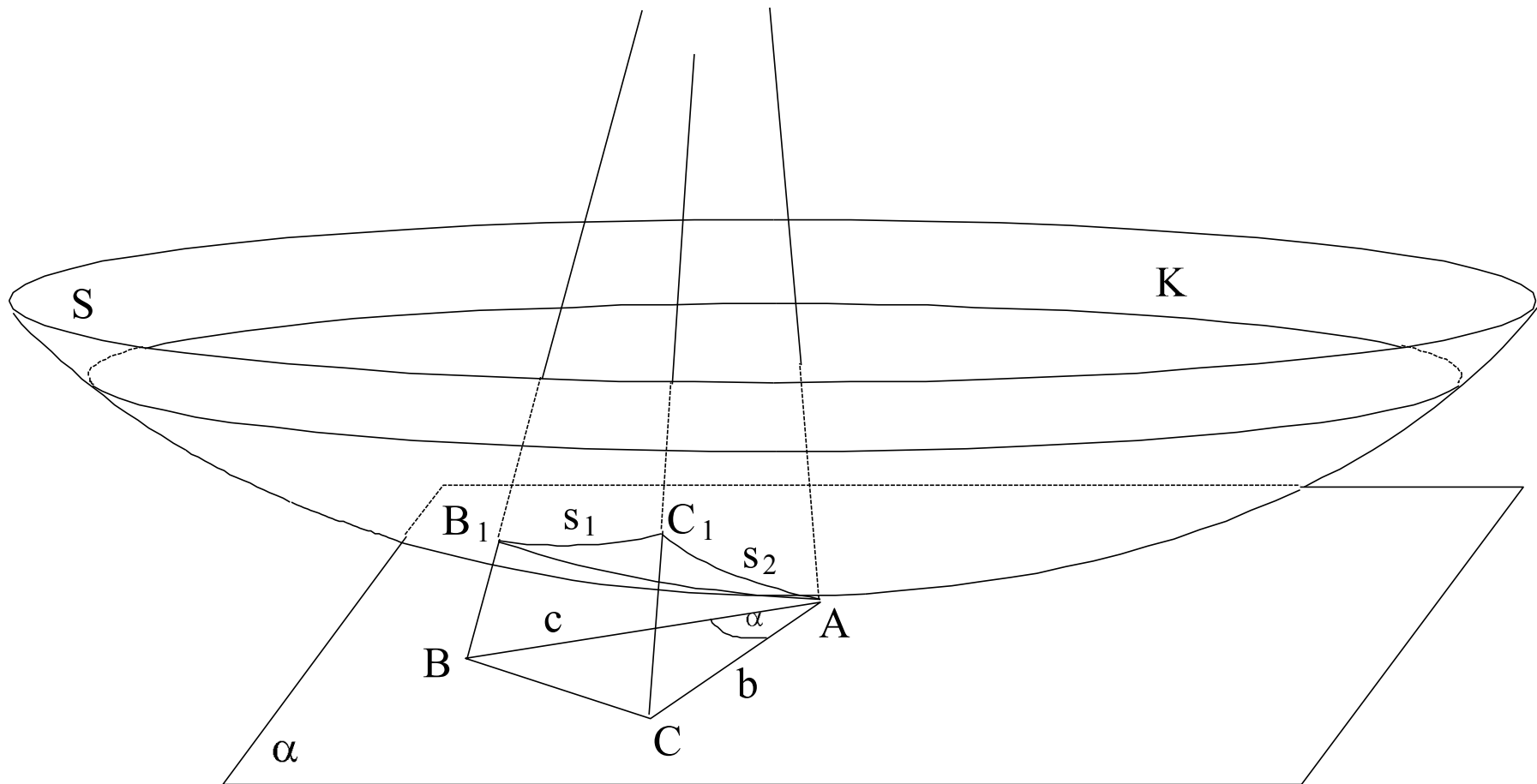

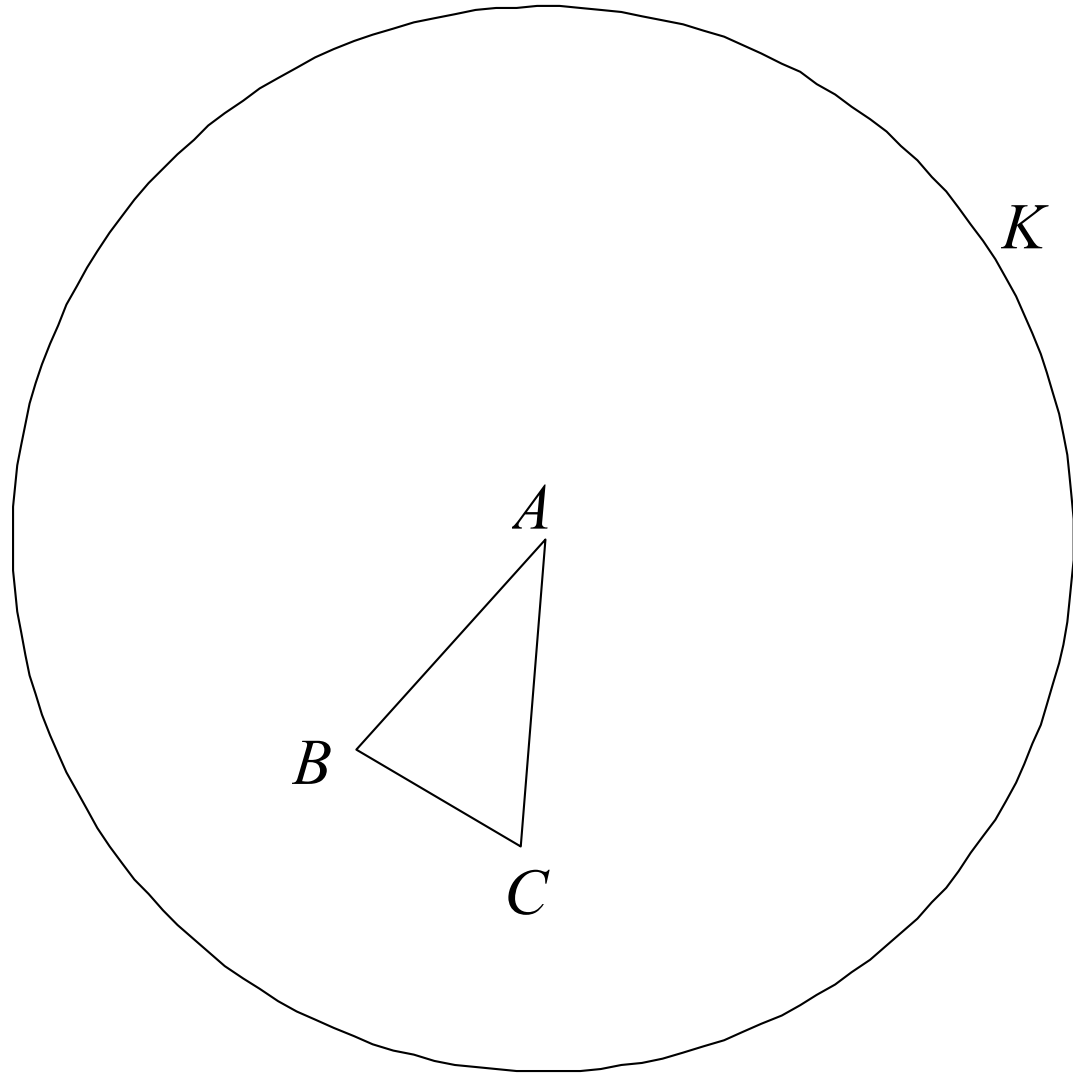

Eugenio Beltrami (1835 - 1900)

VONKAJŠÍ JAZYK

- K*** kruh euklid. roviny
A bod vovnútri kruhu *K*
a tetiva kruhu *K*
p*₁** tetiva pretínajúca ***a

VNÚTORNÝ JAZYK

- horizont neeuklid. roviny
bod neeuklidovskej roviny
priamka
rovnobežka k ***a***

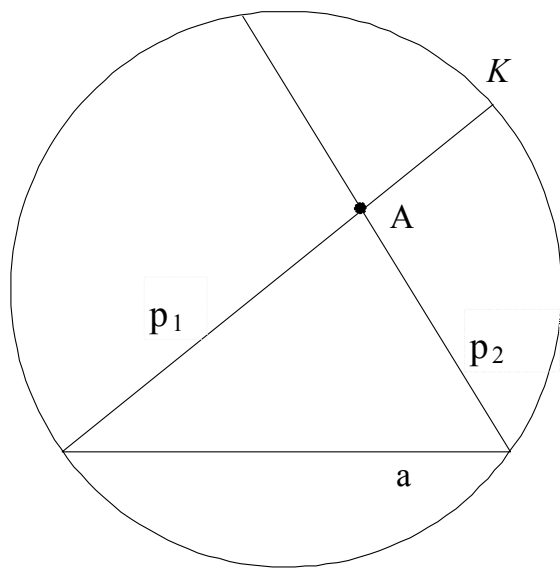

Joseph Turner
(1775-1851)

*Dážd', para,
rýchlost'* (1842)



Auguste Renoir
(1841-1919)

Hojdačka (1876)

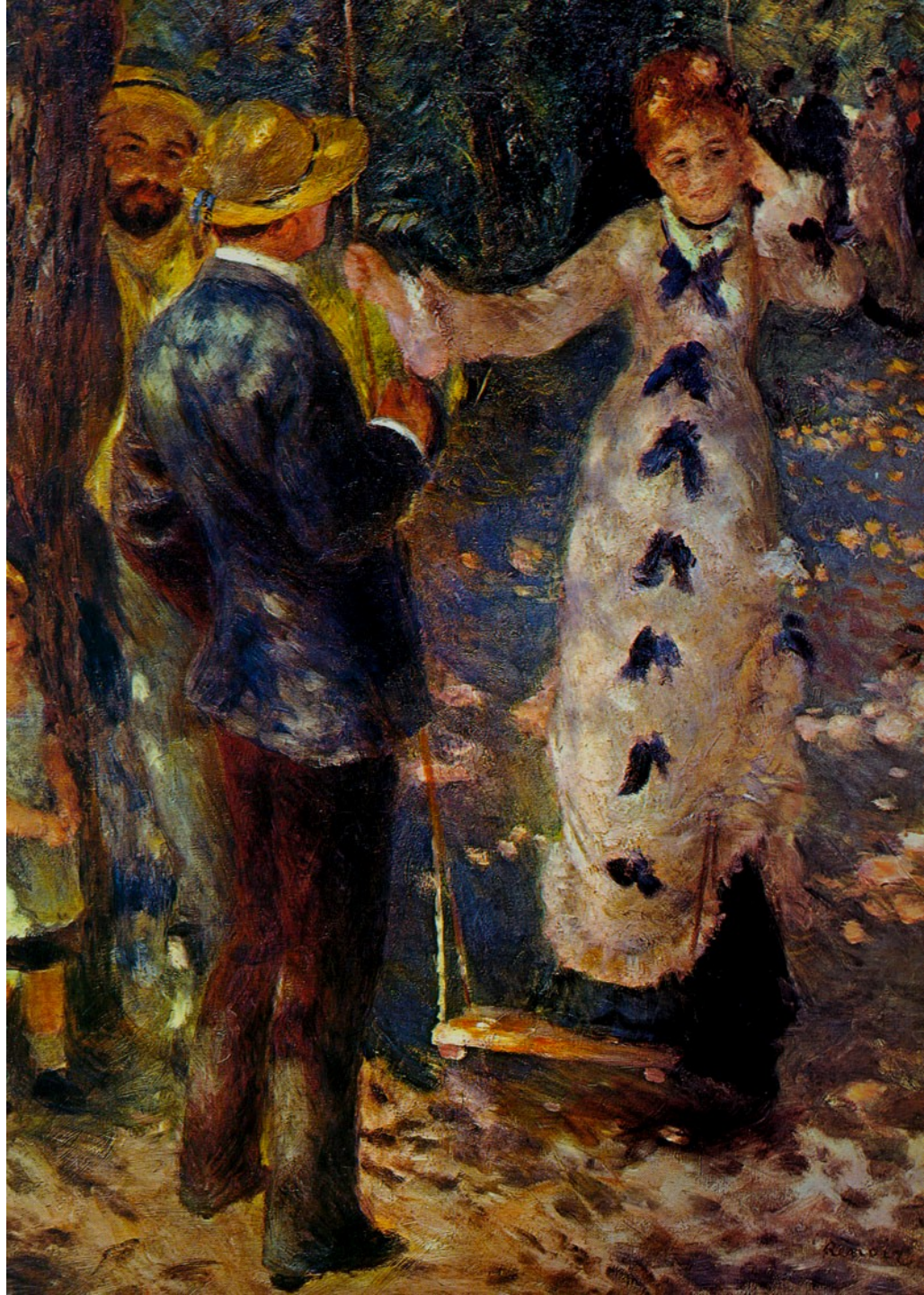

Calude Monet (1840-1926)
Kúpajúci sa v La Grenouillere (1869)



Georges Seurat (1859-1891)

Nedel'né poobedie na La Grande Jatte (1885)



Beltrami:

$$E \longrightarrow L \qquad (E \longrightarrow E)$$

Cayley:

$$E \longrightarrow P \longrightarrow L$$

Klein:

$$G_E \longrightarrow G_P \longrightarrow G_L$$

Paul Cézanne (1839-1906)
Zátišie s košíkom ovocia (1885)



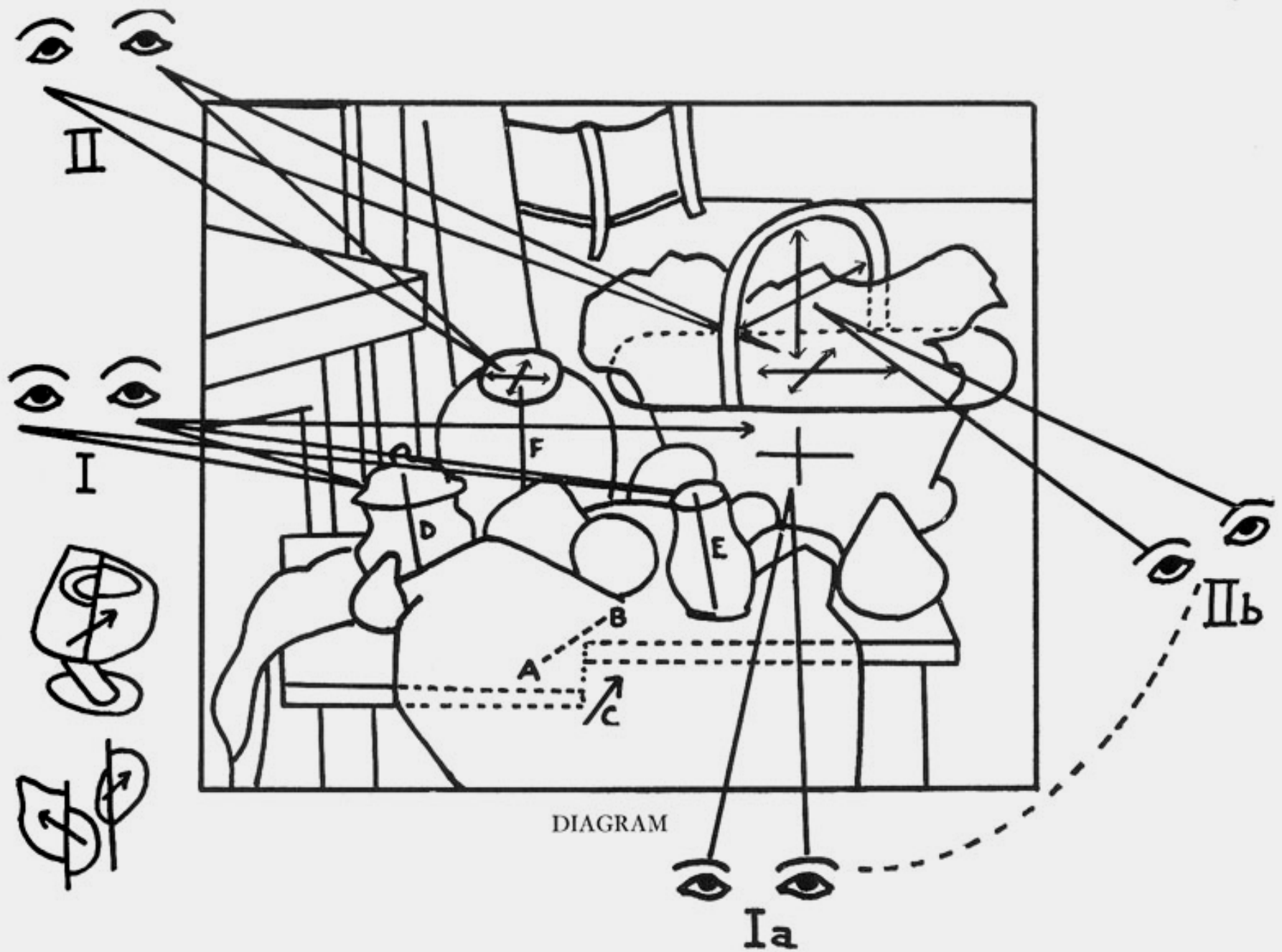

Georges Braque
(1882-1963)

Portugalec (1911)



Pablo Picasso
(1881-1973)

Akt (1910)

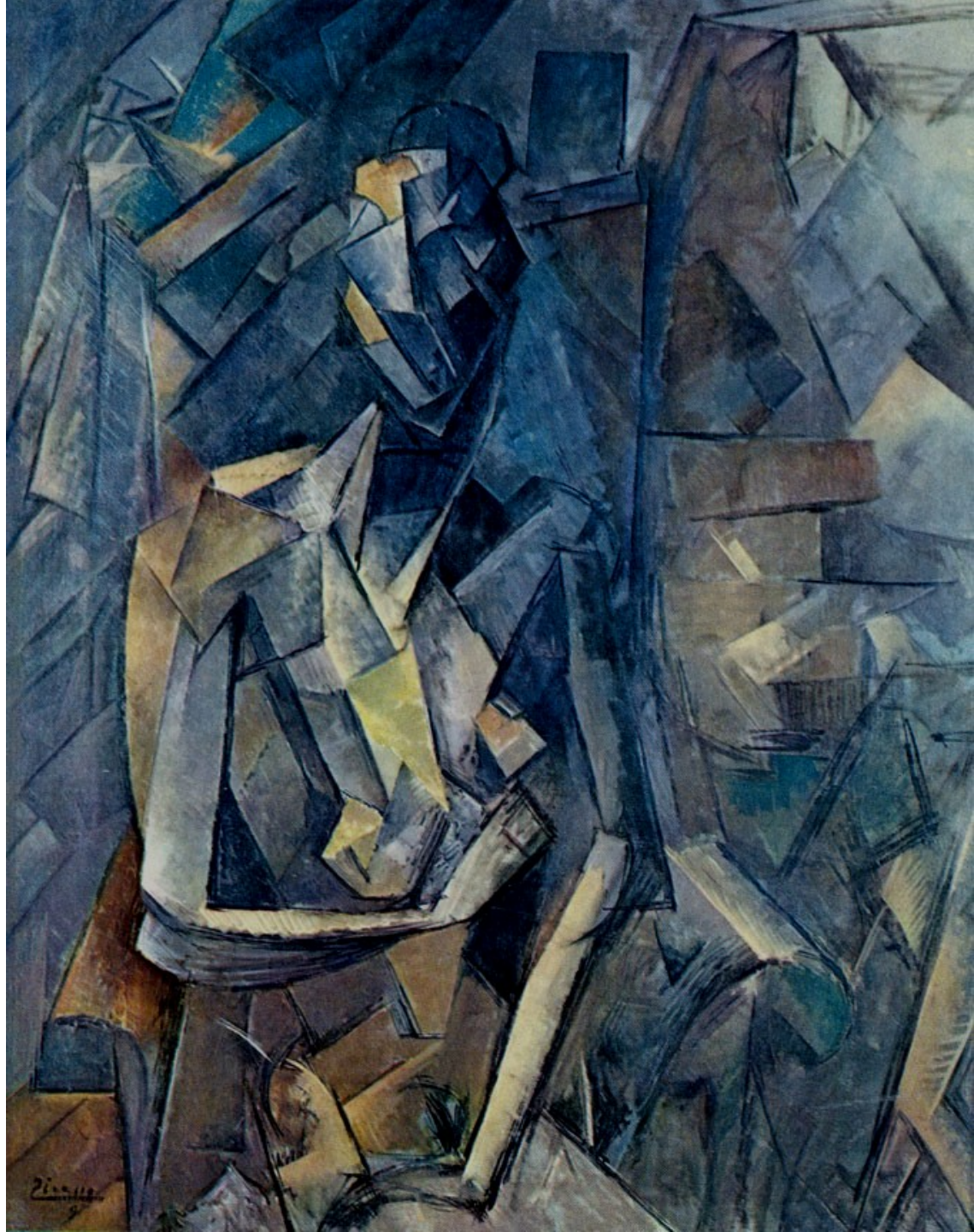

Vasilij
Kandinskij
(1866-1944)

Obraz s
čiernym
oblúkom
(1912)

