



1

Ekopsychologie

Ekopsychologie je vědecký obor, který studuje lidské prožívání a chování ve vztahu k přírodě, krajině a životnímu prostředí.

ecopsychology * conservation psychology * environmental psychology

2

...re you waiting for time to show you some better the interval you spent reading or hearing this, keep it his, be ready! Forgiveness is the fragrance the viol he loudest minds. Height of the heavens, depths of it topped living your life their way. I have looked into ou end up or with whom, it always ends up just the way ow you feel, always. be you and be OK with it. If you cannot be controlled. I am tired of denying myself what I she glances at the photo and the pilot light of memory fill d with the passion of another, as in laughter, tears, foo the city of your comfort and go into the wilderness of your ood things happen every day. I believe good things happen e life, isn't it? we sometimes encounter people, even perfect en. There is a point of maturity when some experiences or oc ture into memories because christmas time is here. may you be it would have been wonderful. I want a life that sizzles and pl is a collections of meetings and pop cans and errands and receipt ar pink shoes and stay up all night laughing and paint my walls lives and read books so good they make me jump up and down and i ow do you define a word without concrete meaning? to each his ow here you want to be? Faultless. Finished. Incomparable. People o love the person who lives inside your skin! The outside belongs rifting snowflakes from the air with your fingertips and not crushi f she loves you now what else matters? she's not perfect, you aren't o think twice and admit to begin human and making mistakes, hold ont ill give you a part of her that she knows you can break. her heart. n she makes you happy, let her know when she makes you mad, and miss e that they were the big things. what would happen if one day you dec you never cross the ocean unless you have the courage to lose sight of the spark? what you need to know about the past is that no matter what oment, and at this moment you can choose to make everything new. righ they saw each other and like the stars in the sky separated by millions

...et give me the moon like the moonlight respects that you impse that you found: carry into evening all that you want ing right here, right in this room, when you turn around? S ply the opportunity to begin again, this time more intelligen ople are around you. When someone says, "you've changed" it: our heart. Take chances, take a lot of them, because, honest are, you learn and grow with each choice you make, everythin tired of trying to hold things together that cannot be held. Tr ix, they will break no matter what i do. I am more than what yo he stuff in the images-in reserve. It is most powerful when sha just like there is a piece of the sky in the sea, you have to leavi onderful, what you will discover is yourself. But i believe that, on a happy day like today we can still feel a little sad, and that' st sight, somehow suddenly, all at once, before a word has been spo to call upon. This is a gift that just happens and many experiences f s holiday season. There are so many beautiful reasons to be happy. I n't want to get to the end of to tomorrow even and realize that my life cold tangerines and sing out loud in the car with the windows open and ow. I want to sleep hard on clean white sheets and throw parties and eat laugh glad that he gave life to someone who loves the gift of life itself. attain an ideal state of being that no two random people will agree is w when did creating a flawless facade become a more vital goal than learning icide for you what is perfect. elusive. it was like delicately grabbing first or her last or her only. she loved before she may love again, but i ou may never be perfect together, but if she can make you laugh, cause yo t you can., she may not be thinking about you every second of every day be st change her. don't analyze and don't expect more than she can give. smile wh A mental map. Enjoy the little things in life for someday you will reali to follow your heart? going back to a simpler life is not a step backwards. the shore. beauty without grace is the hook without the bait. Do you feel has happened it has all worked out the way it should to bring you to this very take the ride. they did not speak they did not bow they were not acquainted ed by gazing upon one another. welcome to today. Everything eventually connects

Mýtus 1.
Lidem chybí dostatek informací,
aby mohli chránit životní prostředí.

3



K.A.B. model

4

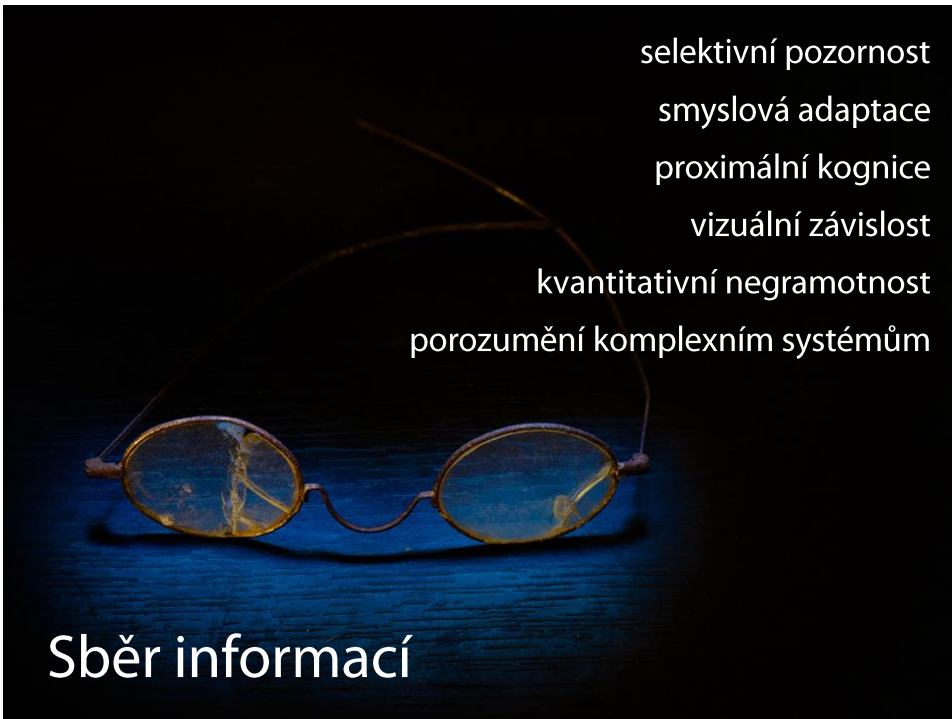

selektivní pozornost
 smyslová adaptace
 proximální kognice
 vizuální závislost
 kvantitativní negramotnost
 porozumění komplexním systémům

Sběr informací

5



Zpracování informací

kognitivní disonance
 heuristiky
 (např. dostupnosti,
 afektivá,
 nerealistický
 optimismus)

6

lidská racionalita?

7

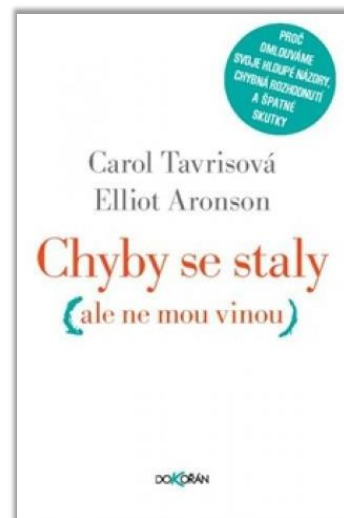
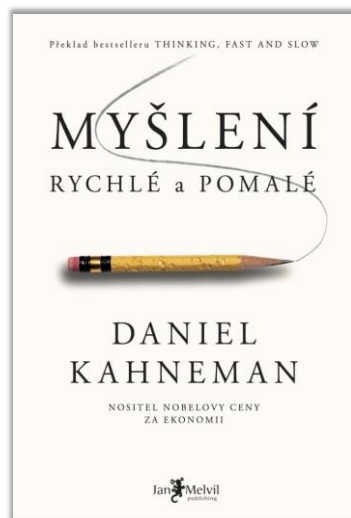

8



9

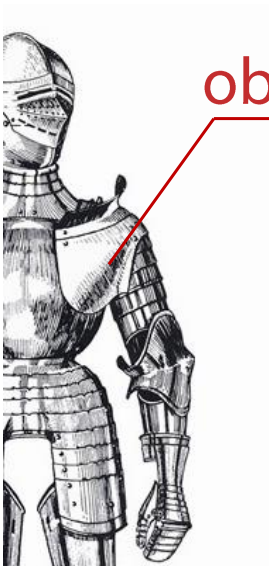

obrané mechanismy ega

10



http://bit.ly/epsy_emoce2012

11



12

sociálně konstruované environmentální diskurzy

- selektivní pozornost
- neviditelné problémy
- smyslová adaptace
- heuristika dostupnosti
- srovnávací optimismus



13



Mýtus 4.

**Lidem chybí správné hodnoty a postoje,
aby mohli chránit životní prostředí.**

14



K.A.B. model

15

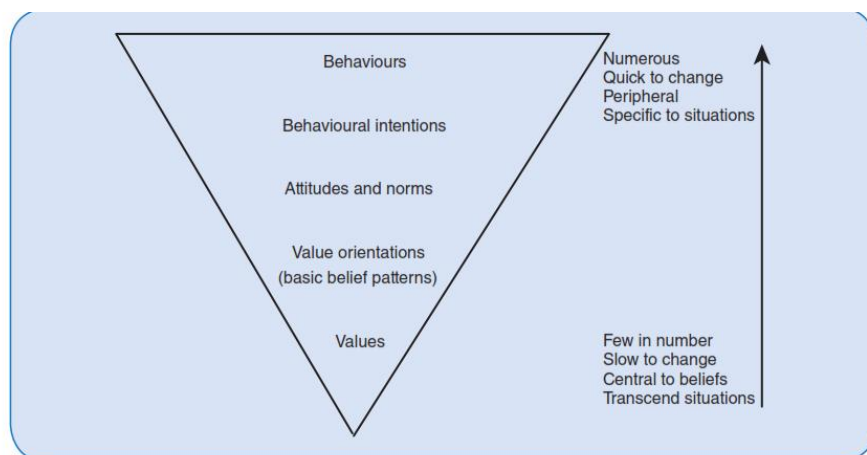

16



Mýtus 5.

**Lidem chybí kontakt s přírodou,
aby mohli chránit životní prostředí.**

17



Mýtus 6.

**Lidé jsou příliš hloupí, sobečtí nebo narušení,
aby mohli chránit životní prostředí.**

18



- nedostatek informací o alternativách (v obchodech i v restauracích)
- pocit zahlcení výzvami, čeho všeho si má člověk všimnout při nákupu
- nedůvěra vůči doporučením
- nejistota, jaká je vazba mořského jídla na zdraví

19

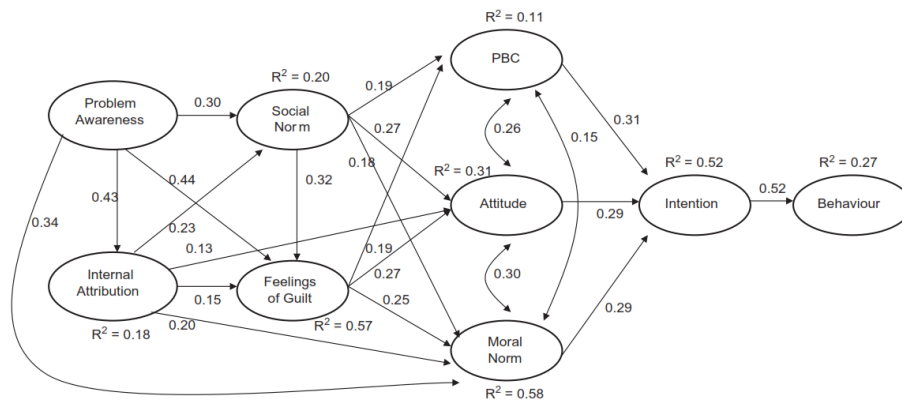

Bamberg, Möser (2006)

20

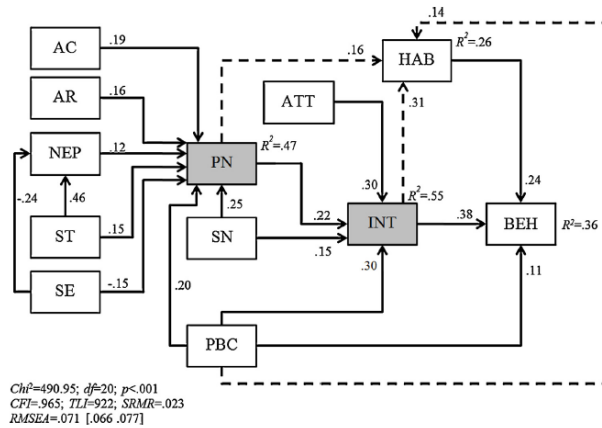

Fig. 4. Results of the meta-analytical structural equation modelling based on the pooled correlation matrix. Notes. All exogenous variables (ST, SE, AR, AC, ATT, PBC, SN) are specified to covariate. The respective correlations can be found in Table 1. AC, awareness of consequences; AR, ascription of responsibility; ATT, attitudes; BEH, behaviour; HAB, habit; INT, intention; NEP, new environmental paradigm; PBC, perceived behavioural control; PN, personal norm; SN, social norm; ST, self-transcendence values; SE, self-enhancement values.

Klößner (2013)

21



22



23

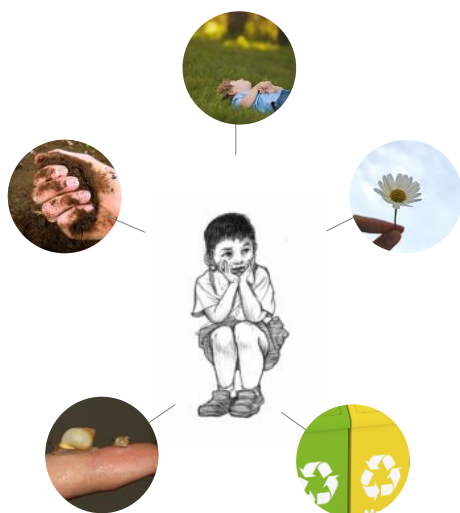

Potřeba kontaktu s přírodou

„Vyhledávám kontakt s přírodou, kdy to jenom jde.“

Adaptace na přírodní prostředí

„Postarám se o sebe v přírodě - v různých podmínkách i situacích.“

Estetický postoj k přírodě

„Všímám si přírody kolem sebe, připadá mi krásná.“

Etický postoj k přírodě

„Neubližuji přírodě kolem sebe, snažím se jí chránit.“

Environmentální vědomí

„Chovám se tak, abych nepoškozoval životní prostředí.“

24

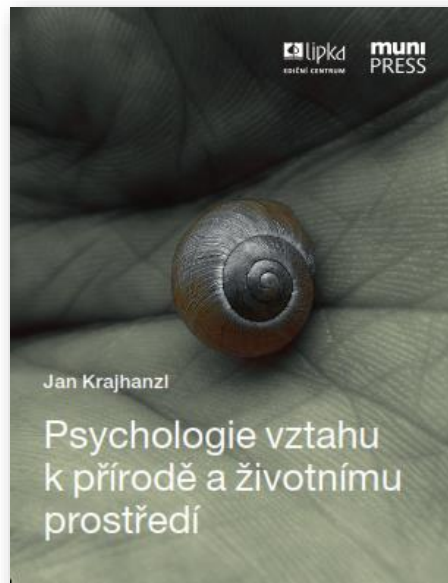

25



Závěr

Kriticky o vztahu k přírodě a životnímu prostředí

26

Co dál?

Tipy k dalšímu studiu

27



28



Český portál ekopsychologie

O vztahu k přírodě a životnímu prostředí



Čítárna | Zajímavosti | Orientace v oboru | Vzdělávání | Newsletter | O nás | vyhledávání

American Psychological Association: Psychology and Global Climate Change: Addressing a Multi-faceted Phenomenon and Set of Challenges

19. 3. 2014 | Doporučujeme >

Doporučujeme zprávu týmu špičkových odborníků Americké psychologické asociace.

[celý článek >](#) [o komentářích >](#)



Kontakt s přírodou

Proč lidé (ne)chrání?

Komunikace s veřejností

Věda a výzkum



Human-Animal Studies: Sociologie lidsko-zvířecí interakce a vztahů

4. 3. 2014 | Doporučujeme >

Sociologové připomínají, že obrazy lidské společnosti je bez zvířat vždy neúplný. Článek představuje nový proud sociologie, který se zabývá např. lhostým za práva zvířat, vztahem k domácím zvířatům či profesemi pracujícími se zvířaty.

[celý článek >](#) [o komentářích >](#)

aktivismus conservation psychology
Česká republika děti divočina
dotazník ekonomie ekopedagogika
emoce environmentální psychologie
estetika filosofie identita klima krajina
lesní mateřské školy metodologie mýty
odpady postoje praxe předškolní děti

www.ekopsychologie.cz

29

FSS MU: Literatura z oboru ekopsychologie a dalších spřízněných disciplín ☆ ■

Soubor Upravit Zobrazit Vložit Formát Data Nástroje Doplnky Nápořádě Všechny změny uloženy na Disku

	A	B	C	D	E
1	autor	rok vydání	název	klíčová témata	dostupnost
19	Whitmarsh, O'Neill, Lorenzoni	2010	Engaging the Public with Climate Change: Behaviour Change and Communication	climate change in social sciences	dlouhodobá JK
20	Beattie	2010	Why Aren't We Saving the Planet?: A Psychologist's Perspective	conservation psychology	Peřf MU měsíční výpůjčka
21	Clayton, Myers	2015	Conservation Psychology: Understanding and promoting human care for nature	conservation psychology	dlouhodobá JK
22	Clayton, Myers	2009	Conservation Psychology: Understanding and promoting human care for nature	conservation psychology	FSS knihovna prezenční
23	Clayton, Opatow	2003	Identity and the Natural Environment: The Psychological Significance of Nature*	conservation psychology	FSS knihovna prezenční
24	Corral-Verdugo, Garcia-Cadena, Frias-Armenta	2010	Psychological Approaches to Sustainability: Current Trends in Theory, Research and Applications	conservation psychology	FSS on-line: http://site.ebrary.com/lib/masaryk/
25	Gardner, Stern	2002	Environmental Problems and Human Behavior	conservation psychology	dlouhodobá JK
26	Krajhanzl	2014	Psychologie vztahu k přírodě a životnímu prostředí	conservation psychology	FSS knihovna prezenční + měsíční výpůjčka
27	Nickerson	2003	Psychology and Environmental Change*	conservation psychology	ústní domluva
28	Scott, Amel, Koger, Manning	2016	Psychology for Sustainability, 4th edition	conservation psychology	dlouhodobá JK
29	Winter, Koger	2010	The Psychology of Environmental Problems: Psychology for Sustainability (3rd edition)	conservation psychology	dlouhodobá JK

www.bit.ly/epsy_literatura

30

jan.krajhanzl@gmail.com