

LED diody

- různé velikosti a provedení
- různé barvy a svítivost
- různé elektrické parametry

Nepajivé pole

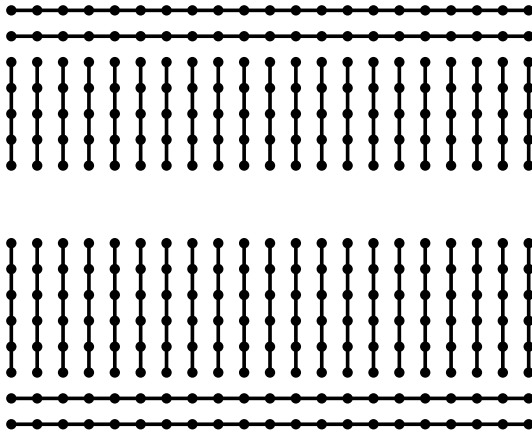

Uloha-1-Blink

Soubor Úpravy Projekt Nástroje nápověda



Blink §

```
void setup() {  
  // initialize digital pin 13 as an output.  
  pinMode(13, OUTPUT);  
}  
  
// the loop function runs over and over again forever  
void loop() {  
  digitalWrite(13, HIGH); // turn the LED on (HIGH is the voltage level)  
  delay(1000);           // wait for a second  
  digitalWrite(13, LOW); // turn the LED off by making the voltage LOW  
  delay(1000);           // wait for a second  
}
```

Uloha-2-LED

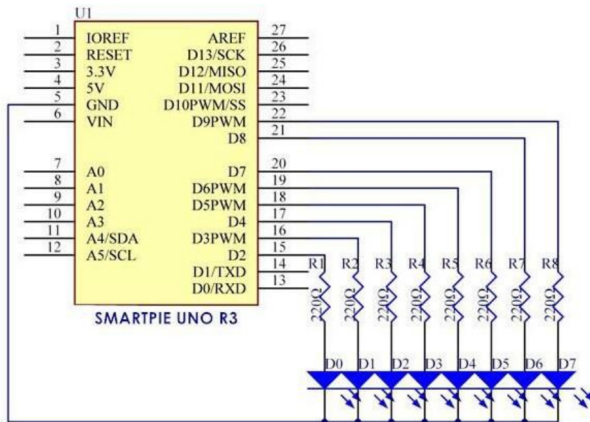

manuál stavebnice KUONGSHUN

Uloha-2-LED

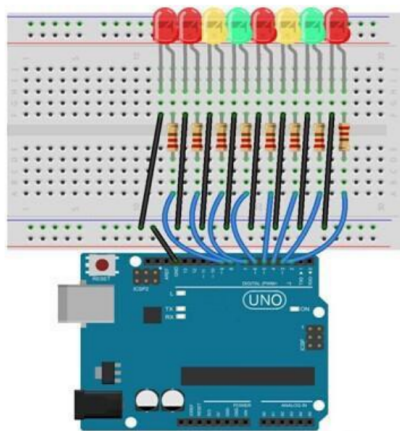

manuál stavebnice KUONGSHUN

Uloha-3-RGB

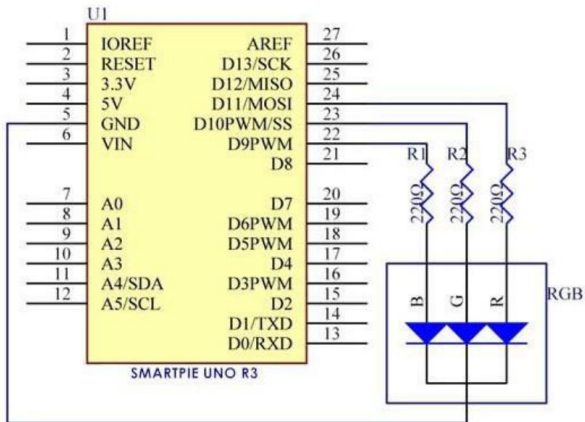

manuál stavebnice KUONGSHUN

Uloha-3-RGB

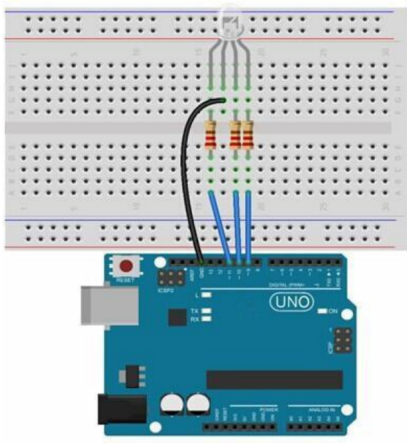

manuál stavebnice KUONGSHUN

Uloha-3-RGB

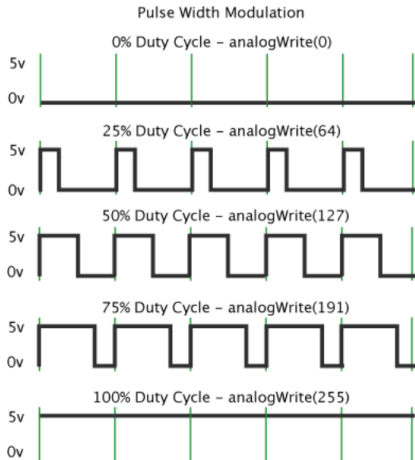

Uloha-4-AB

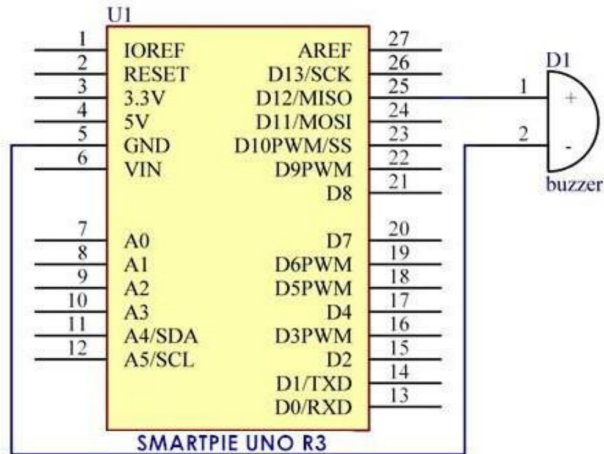

manuál stavebnice KUONGSHUN