

Normal glow discharge $(j/p^2) = \text{konst.}$ (Engel and Steinbeck)

increasing p the current density j is increased dramatically \rightarrow intense Joule heating of the cathode surface \rightarrow **thermoemission** \rightarrow no more glow discharge at typically $p > 10 \text{ kPa}$

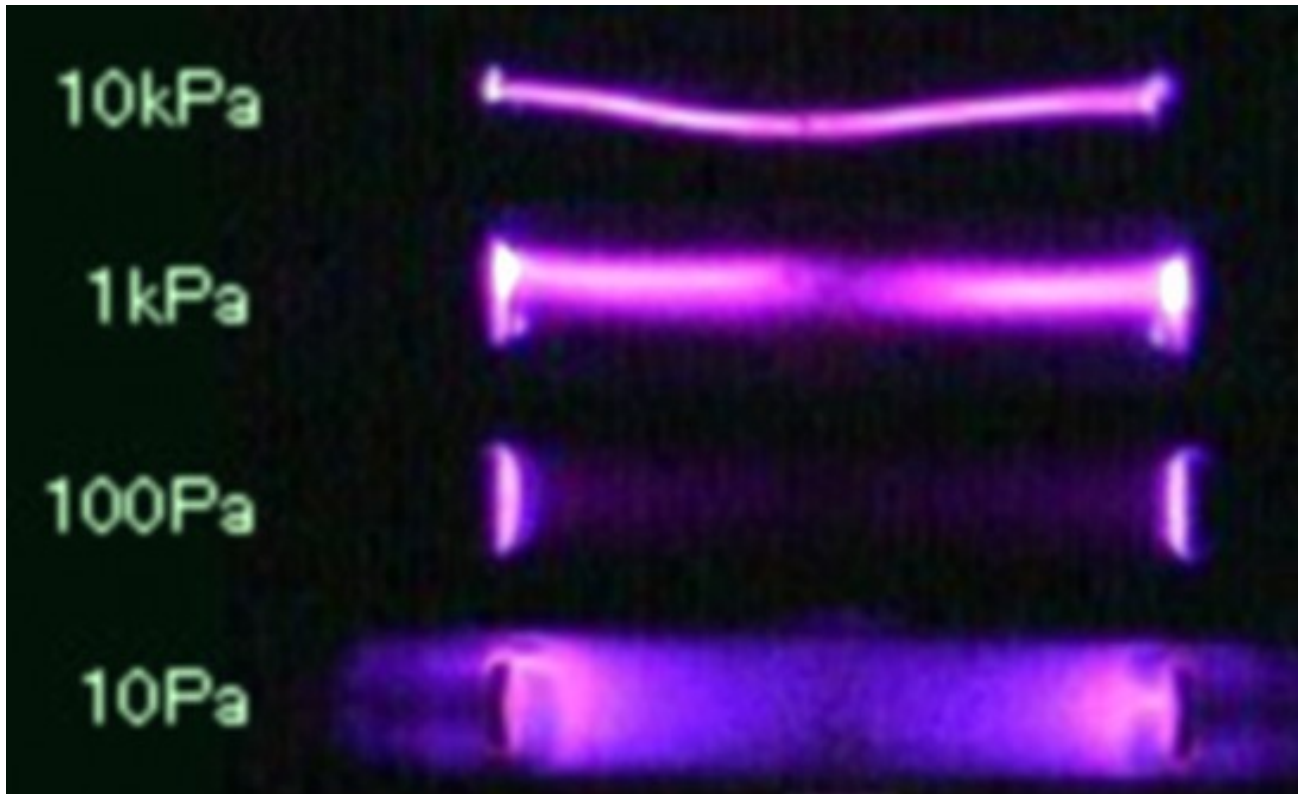

Arc Discharge – At point H, because of Joule heating due to the increasing current density, the electrodes become sufficiently hot that the cathode emits electrons by **thermoemission**. If the DC power supply has a sufficiently low internal resistance, the discharge will undergo a glow-to-arc transition, H-I. The arc regime, from I through J is one where the discharge voltage decreases as the current increases, until large currents are achieved at point J, and after that the voltage increases slowly as the current increases.

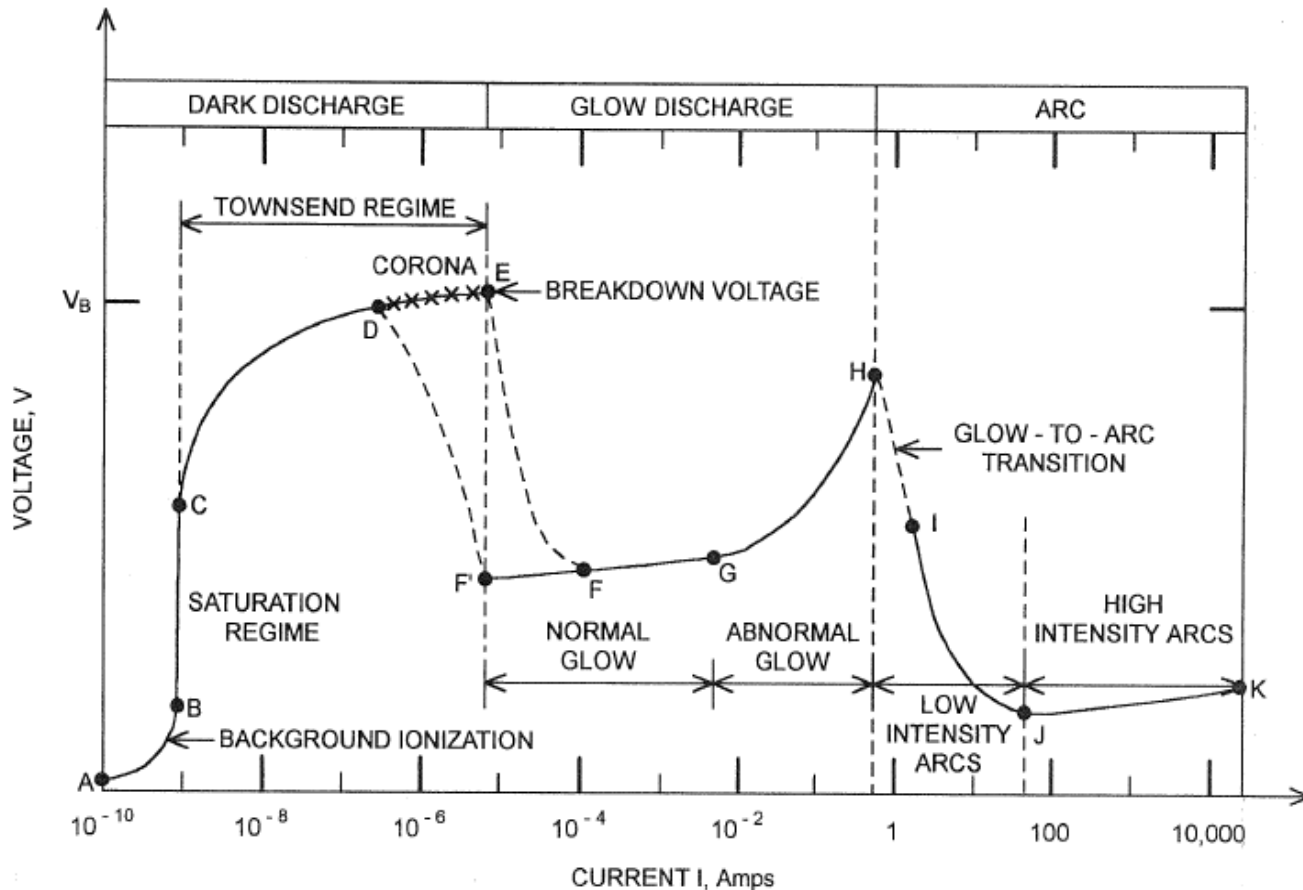

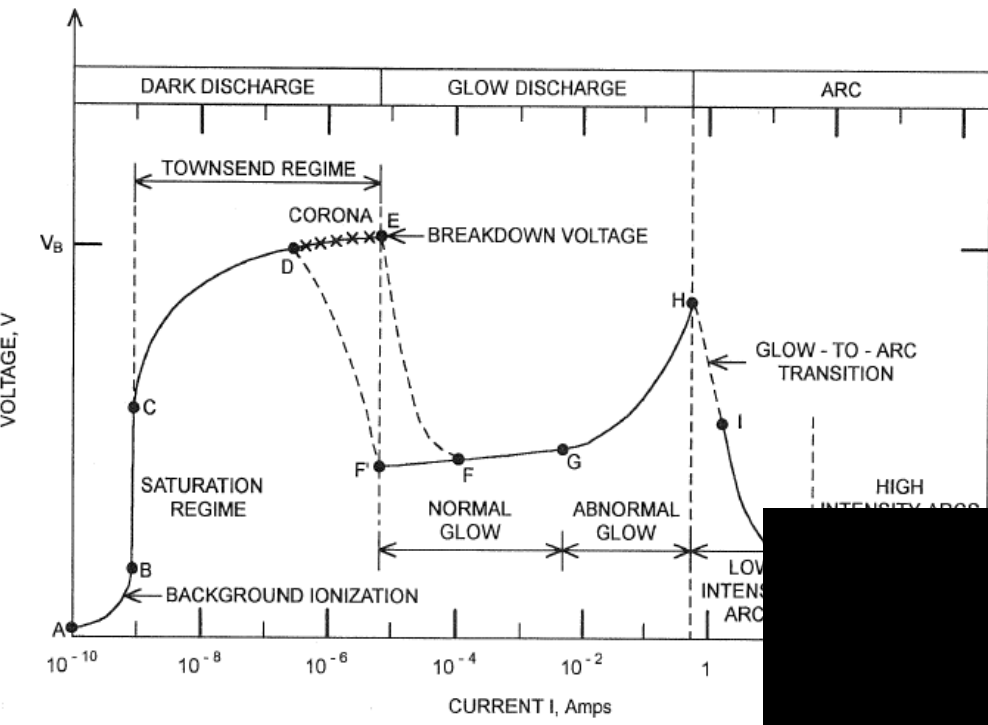

Plasma ball

~ 1atm., Penning mixture of about 98–99.5% of neon with 0.5–2% of argon, 35 kHz, 2-5 kV
glow-to-arc transition

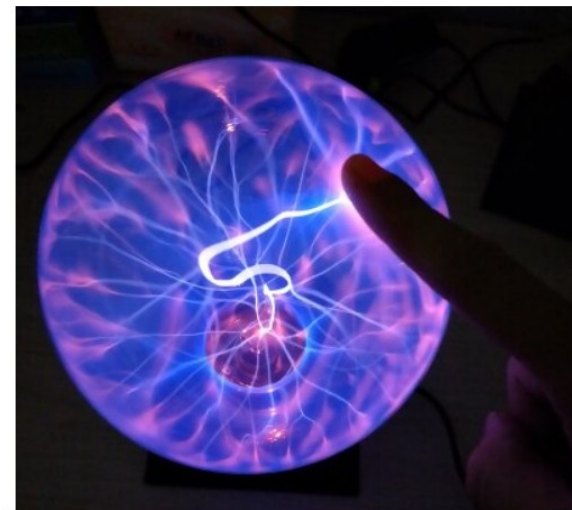
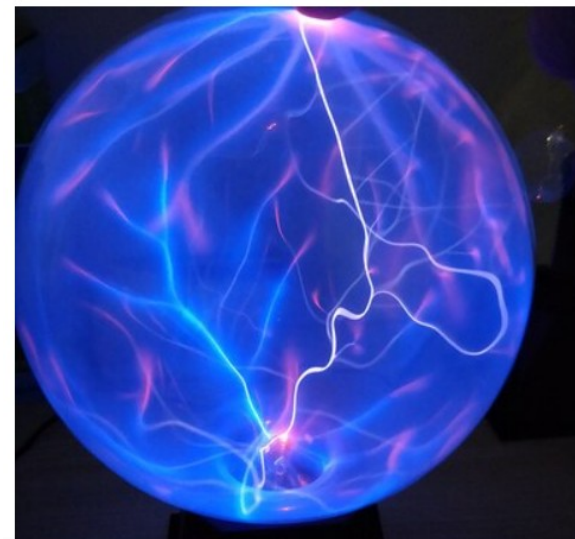
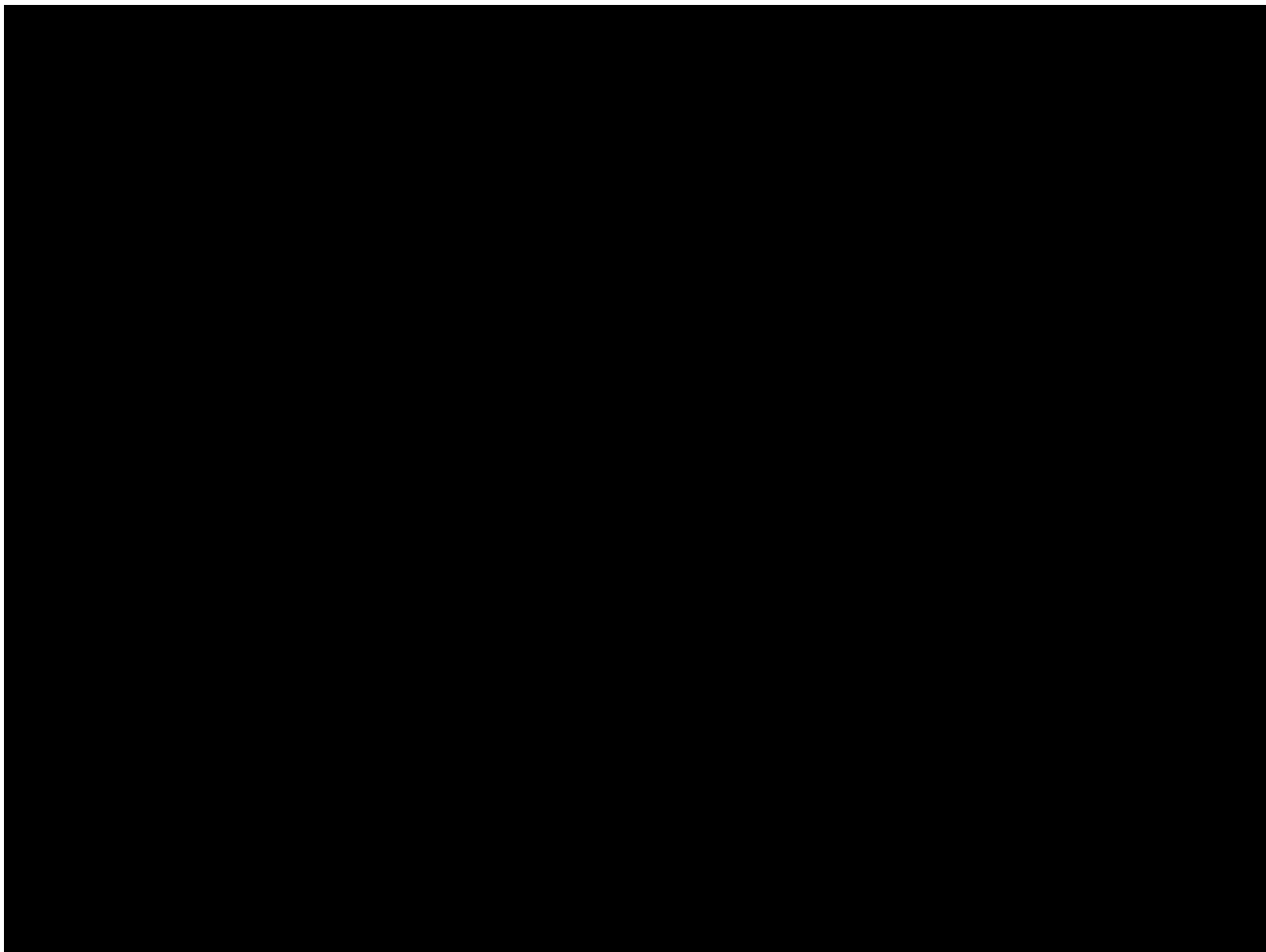

„If the DC power supply has a sufficiently low internal resistance, the discharge will undergo a glow-to-arc transition“

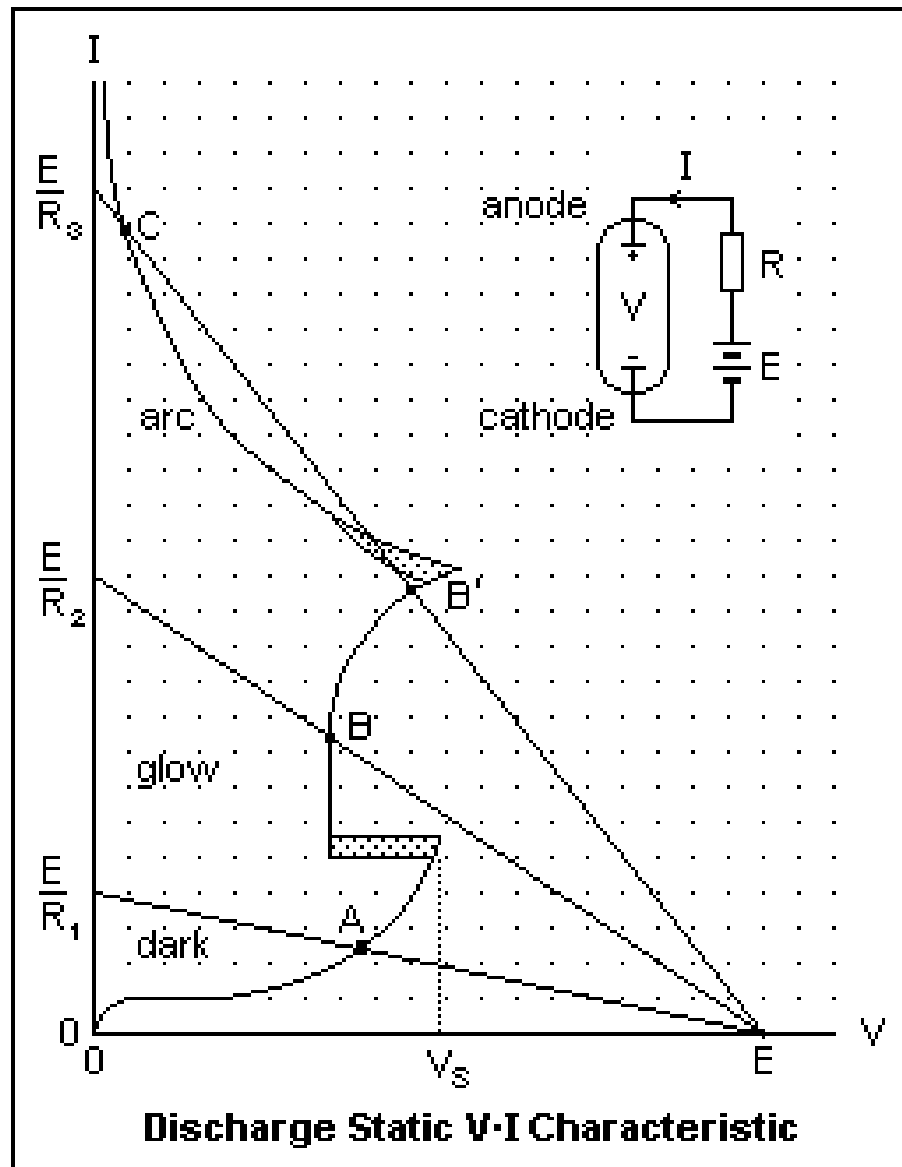

Glow Discharge
Non-equilibrium plasma

Arc Discharge
Equilibrium plasma

Main source of electrons:

electron impact ionization

thermo-emission/field emission
(thermofield emission)

Minimal gap voltage

on the order of 100 V

on the order of 10 V

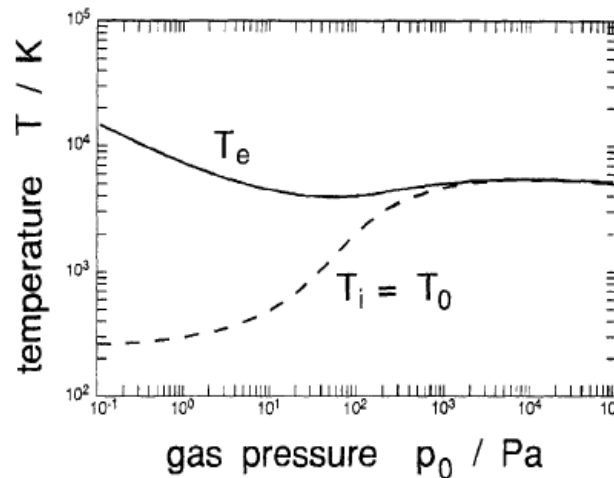

The emission of electrons from the cathode is governed by the surface temperature T_s , the surface electric field E , and the presence of ions in the cathode region. When the emission is only due to the temperature effect and the surface electric field is low, the emission is said to be thermoelectron and the electron current density J_T can be predicted by the Richardson-Dushman equation:

$$J_T = \frac{4\pi e m_e (k_B T_s)^2}{h^3} \exp\left(-\frac{e\phi}{k_B T_s}\right)$$

where

ϕ is the work function of the cathode material.

----->

High surface electric fields induce a reduction of the work function (ΔW -next slide), allowing easier thermal emission of the electrons. This effect is known as the **Schottky effect**. The work function W (ϕ) in equation should be replaced by the modified work function. The Richardson-Dushman formula with the modified work function is commonly called the field-enhanced thermionic equation

$$J(E, T, W) = A_G T^2 e^{-\frac{(W-\Delta W)}{kT}}$$

$$\Delta W = \sqrt{\frac{e^3 E}{4\pi\epsilon_0}}$$

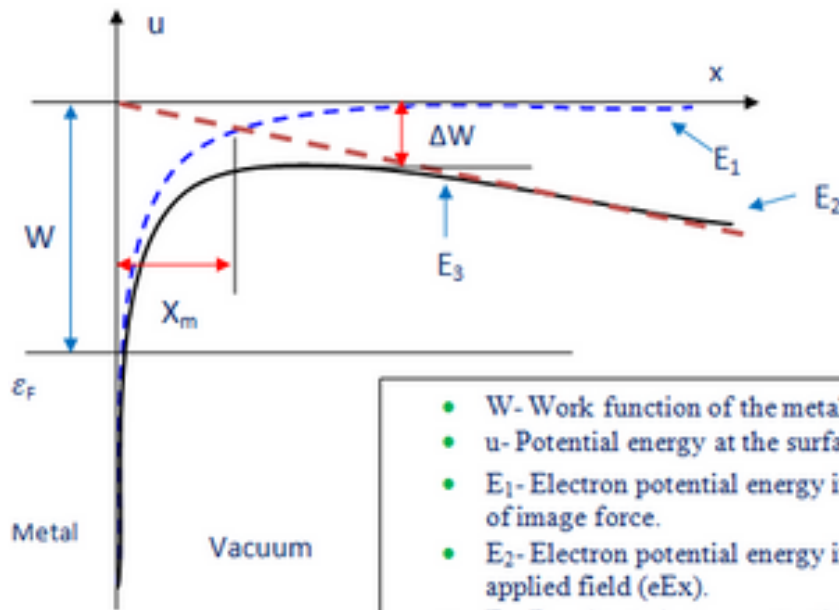

- W- Work function of the metal
- u- Potential energy at the surface
- E₁- Electron potential energy in the field of image force.
- E₂- Electron potential energy in the applied field (eEx).
- E₃- Resultant electron potential energy (in the presence of applied field)
- ΔW-Reduction in work function due to applied electric field.
- ε_F- Fermi level in the metal.
- x- Distance of electron from the surface
- x_m- Distance from the height of potential barrier to the surface of the

Figure 2

Increasing electric field

Cold field emission
(Tunnel effect: quantum tunneling)

Extended Schottky emission
(Thermally assisted field emission)

Schottky emission (Field-enhanced thermionic emission)

Thermionic emission

www.globalsino.com/EM/

Increasing Temperature

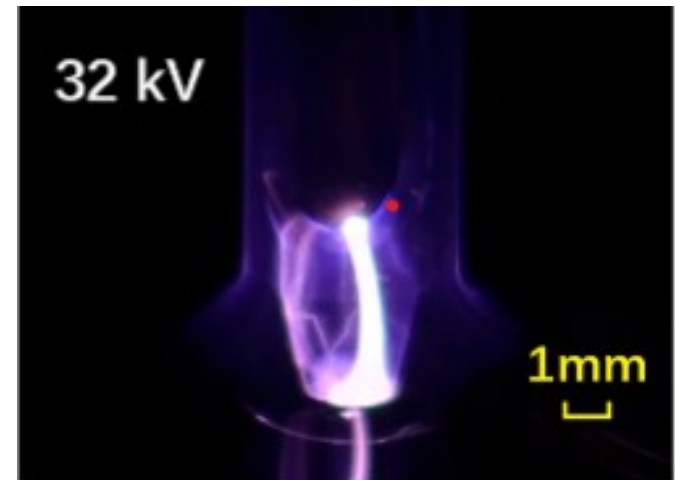

S.Wang et al.: J. Appl. Phys. 125, 043304 (2019): „Characteristic study of a transient spark driven by a nanosecond pulse power in atmospheric nitrogen using a water cathode“

Arc discharge requires the discharge current higher than several Amps and has negative V/A characteristics:

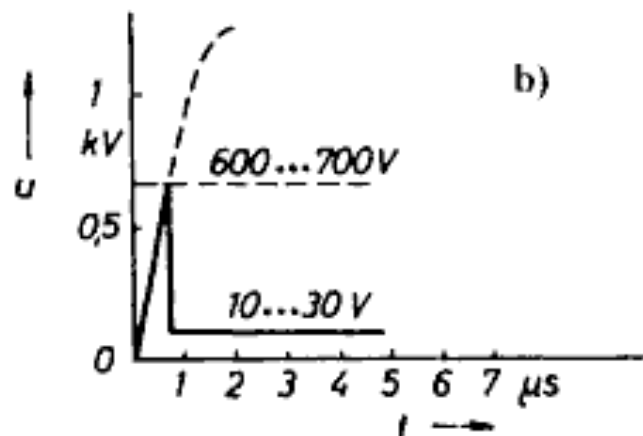
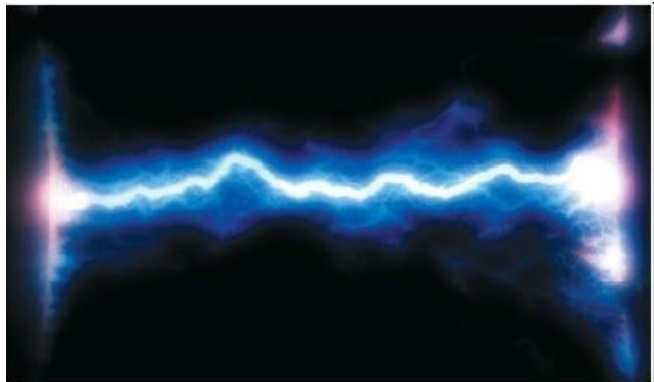
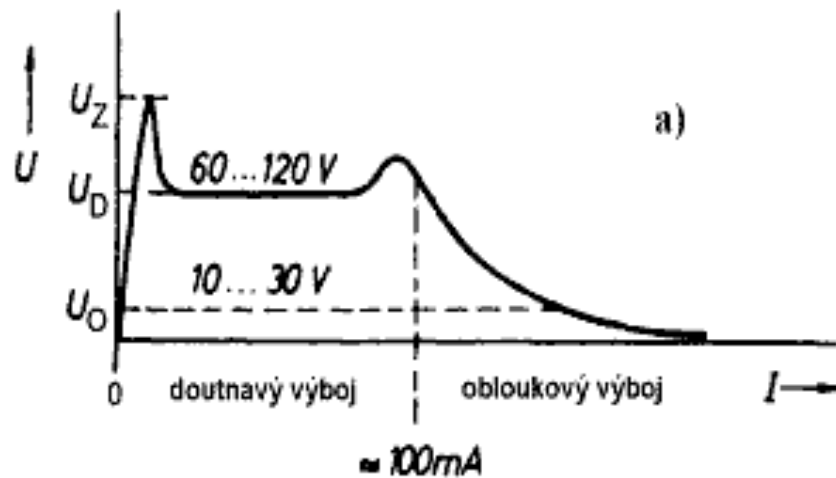

An electric arc which burns in a large gas volume and isn't affected by external factors (e.g., by gas flow or applied magnetic field) is called a free-burning arc. Such an arc burns in arc spots which usually rapidly and randomly move. In special devices, particularly in plasmatrons, it is possible to have a stationary electric arc (e.g., arc burning in a narrow, cylindrical, insulating channel) or to arrange its motion in an ordered fashion. Such electric arcs are called **stabilized arcs**. <https://www.youtube.com/watch?v=d21csX4ZL4U&t=44s>

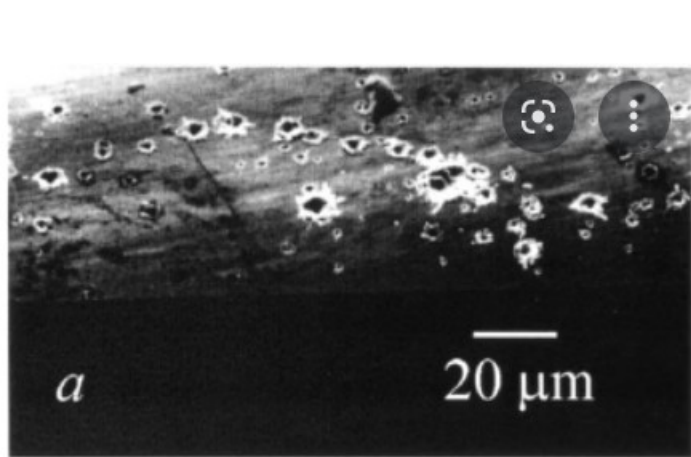

Electric arcs are discharges in **gases and vapours (vacuum arcs)** with currents of more than 1 A and relatively small burning voltages, in general less than 100 V. In contrast to a glow discharge, secondary electron emission is negligible. Typically, the discharge constricts to small footpoints, the cathode spots, leading to energy transfer to the cathode. This causes surface heating to such an extent that thermionic electron emission can cover a part or the whole of the required current. **The cathode voltage drop is typically a little less than the ionization potential of the plasma gas.**

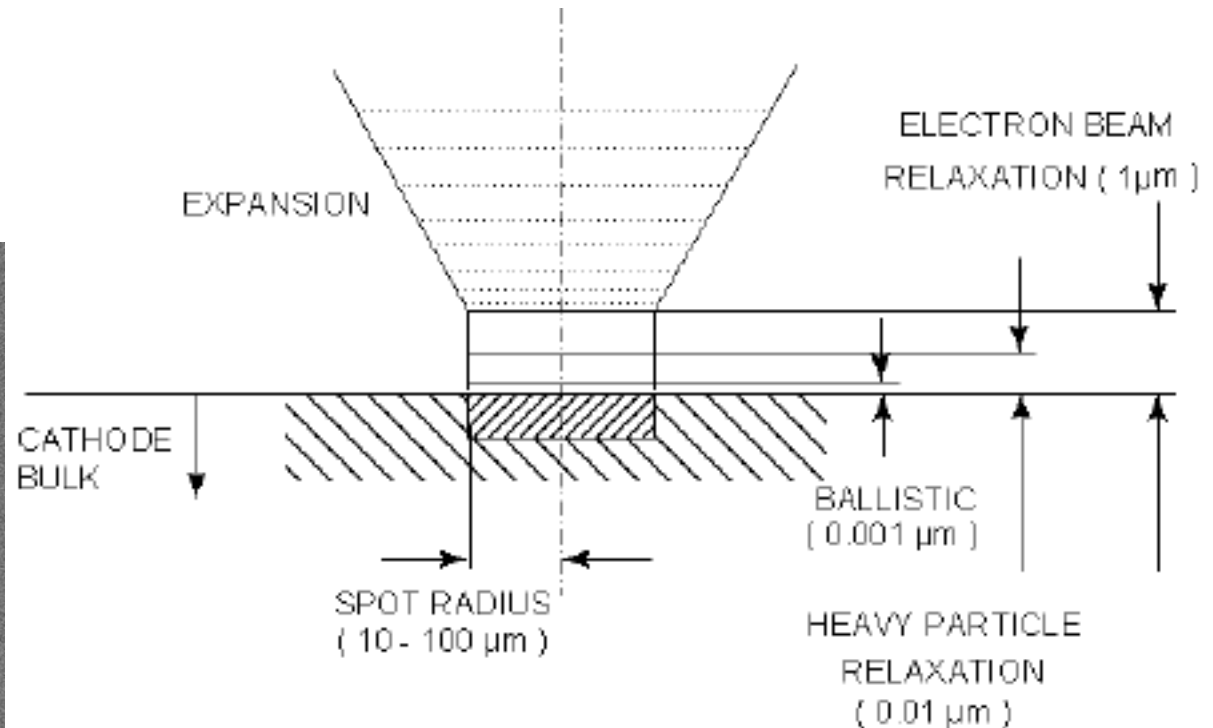
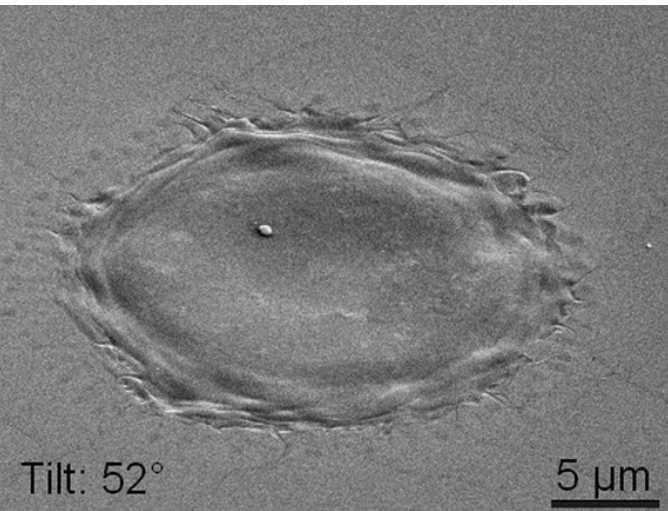

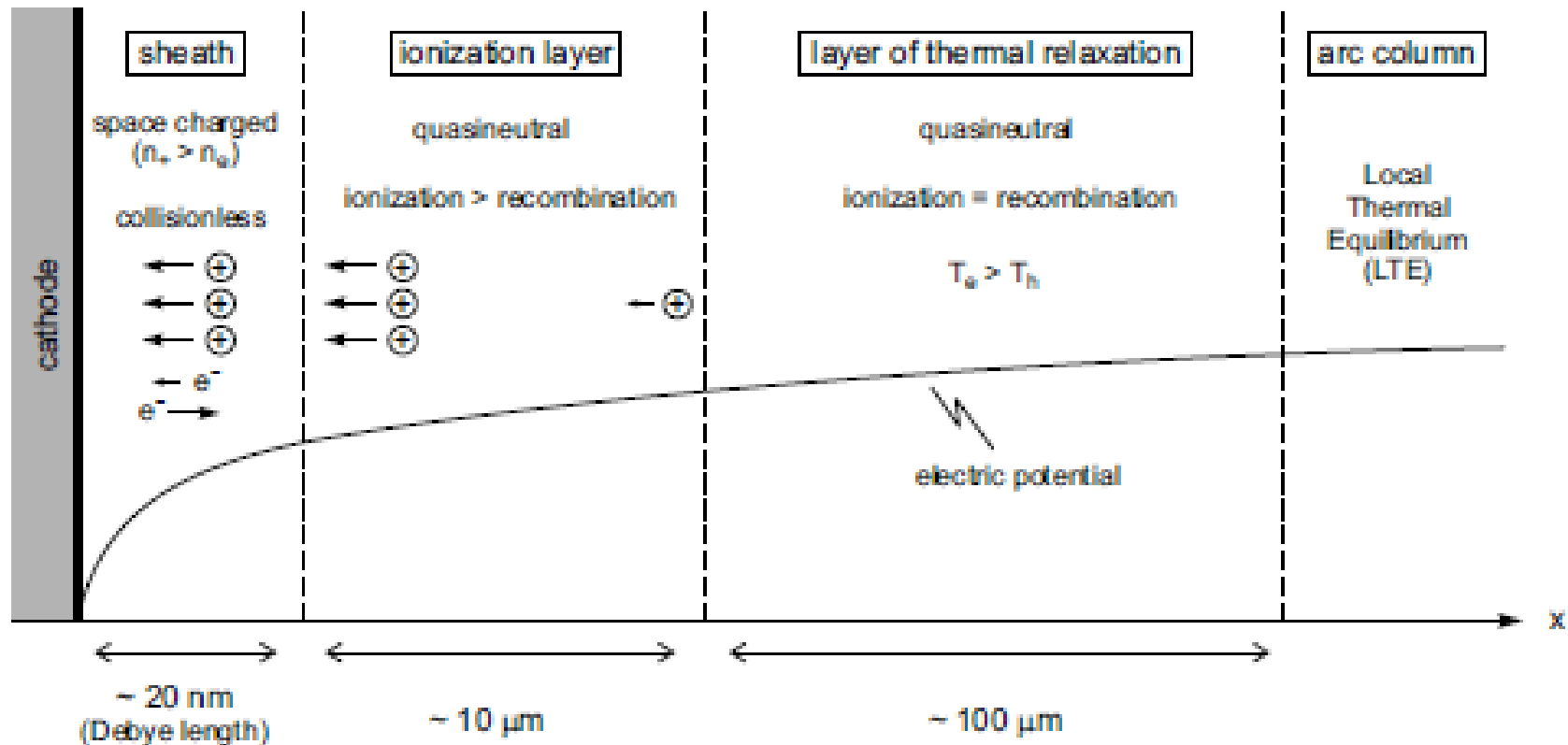
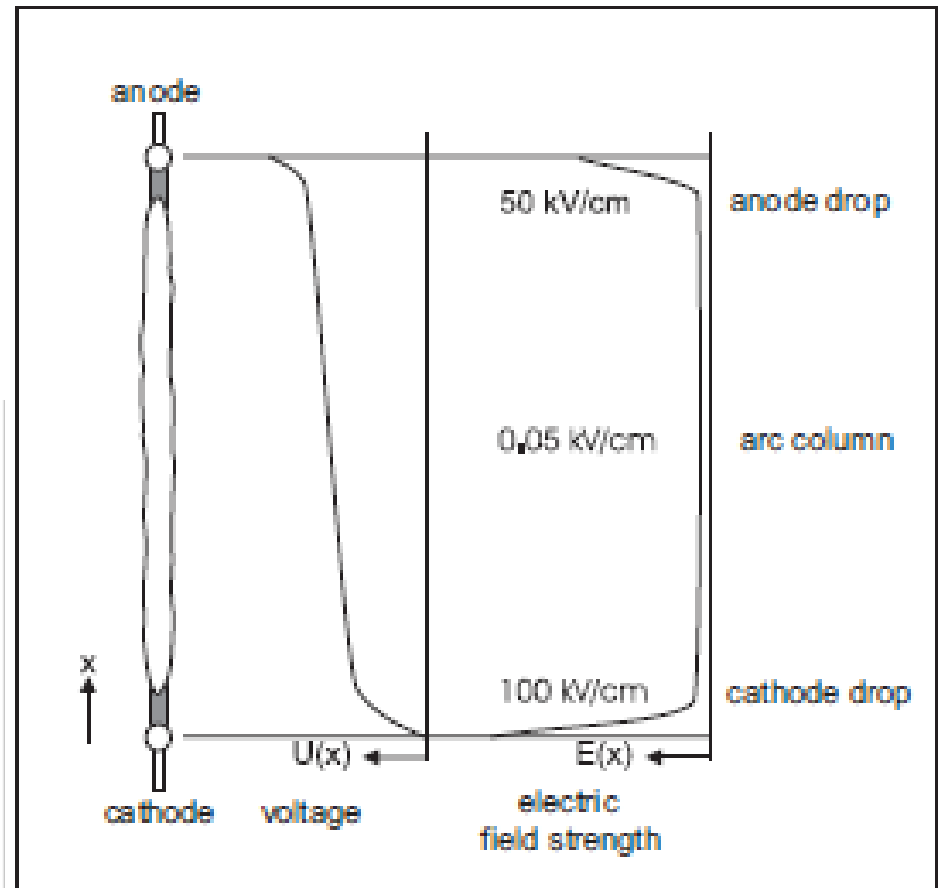

Figure 2.4: Schematic structure of the cathode layer (not to scale). The dimensions of the three layers are evaluated for an argon atmospheric pressure arc plasma at 10'000 K and with a charged particle density of 10^{17} cm^{-3} [53].

[53] M. S. Benilov and A. Marotta, "A model of the cathode region of atmospheric pressure arcs", *J. Phys. D: Appl. Phys.*, **28**(9), 1869–1882 (1995).

Arc discharge column:

- some 99% of the total current is the electron current
- some 1000 electrons are emitted per 1 ion incoming to the cathode (it is not the secondary el. emission !!!)
- The temperature is typically 6 000 – 20 000 K so that the thermal ionization can be also significant (Saha equation)



Comparison of electrical conductivity data of air plasma at atmospheric pressure

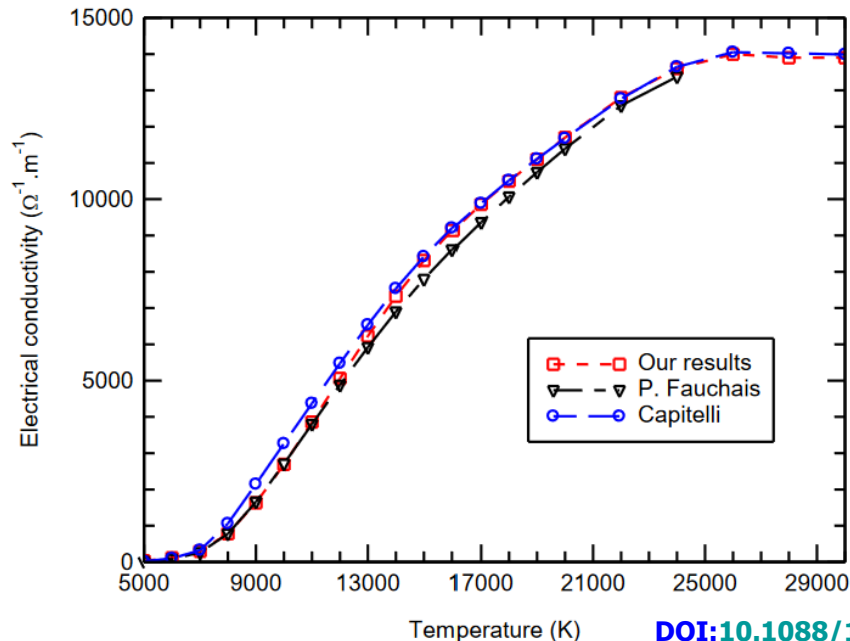

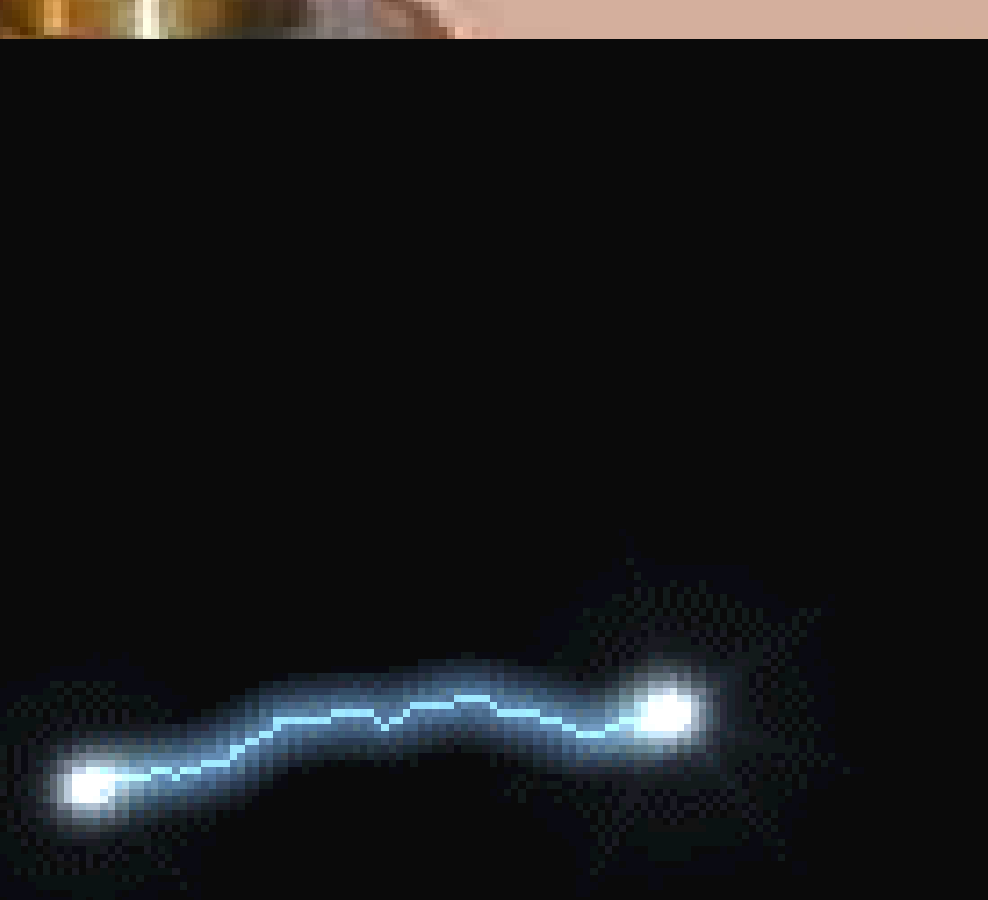

The term “arc” is due to the fact that a sufficiently long discharge between the horizontal electrodes has an arc shape, caused by free-convective vertical gas motion.

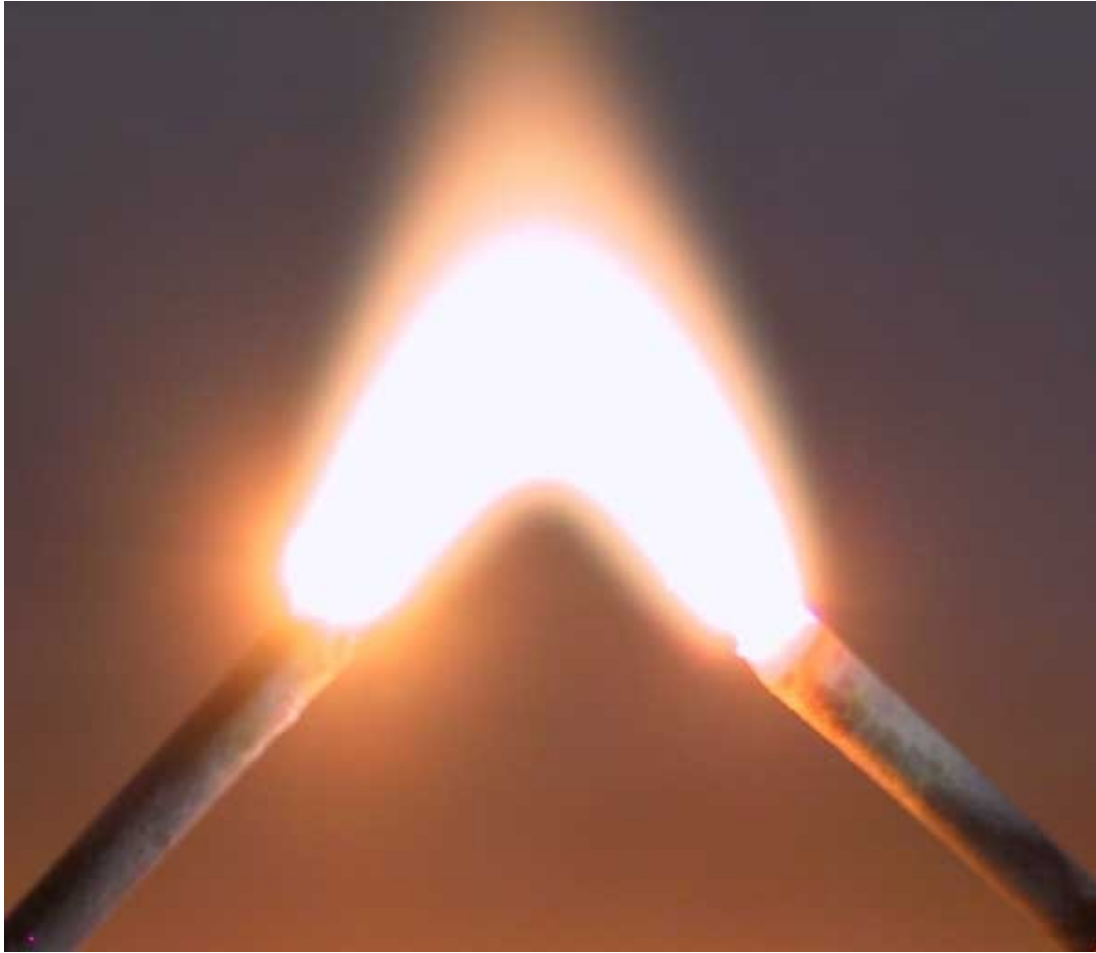

„Gliding Arc“



500 kV High-voltage disconnect-switch arcing



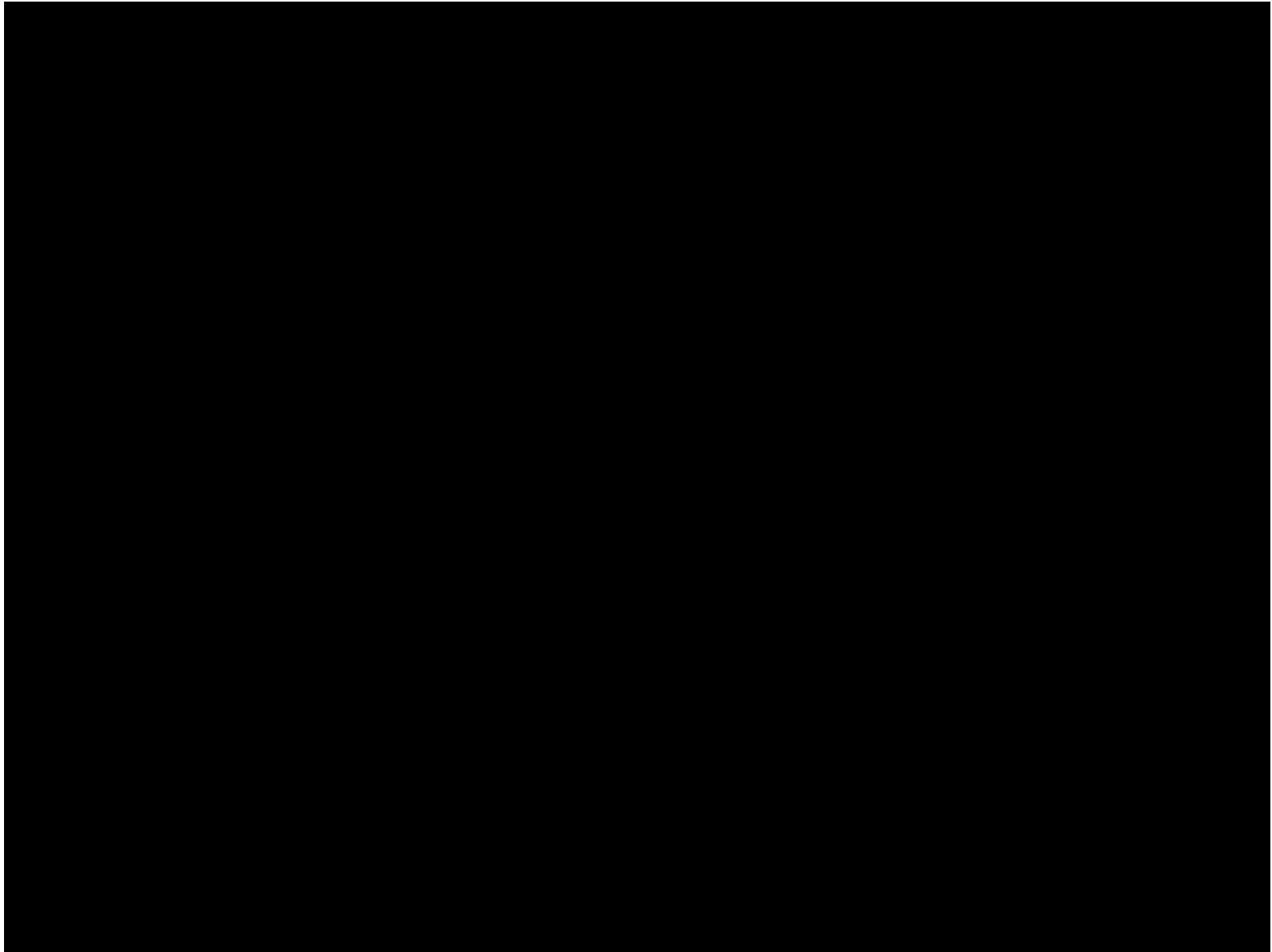

PINCH EFFECT is the tendency of an electric-current channel in a compressible conducting medium to decrease its cross-section under the action of the magnetic field produced by the current. The phenomenon was first described in 1934 by the American scientist W. Bennett with respect to streams of fast charged particles in a gas-discharge plasma. The term "pinch effect" was introduced in 1937 by the British physicist L. Tonks in an investigation of arc discharge. (TOKAMAKs !)

<https://encyclopedia2.thefreedictionary.com/Pinch+Effect>

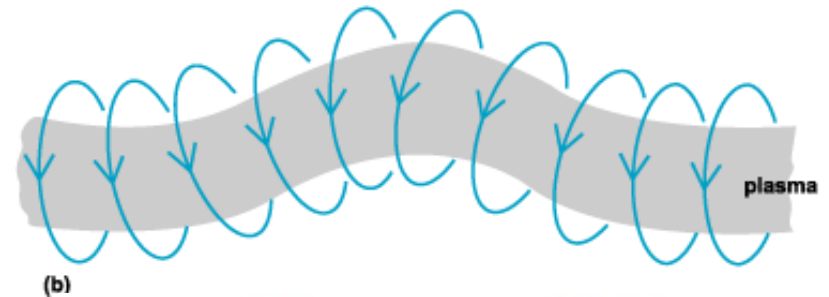
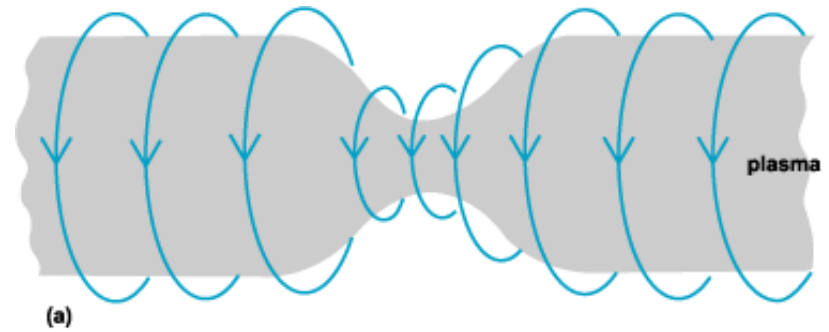
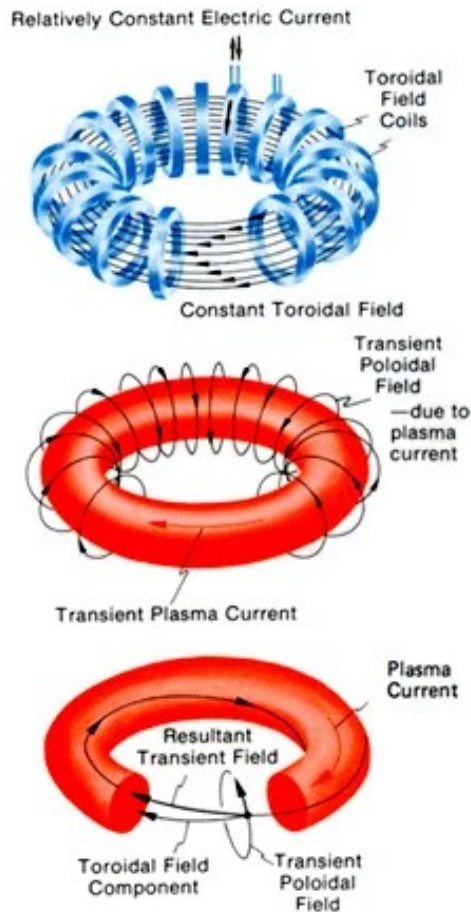

Pinched aluminium can, produced from a pulsed magnetic field created by rapidly discharging 2 kilojoules from a high voltage capacitor bank

<https://www.plasma-universe.com/pinch/>

Arcing issue in fusion devices

- longstanding PSI issue -

- Arcing has been extensively investigated in 1980s in tokamaks.
- Afterward, it has been thought of as a minor issue, because it could be eliminated by advanced discharge control, and the main impurity source is thought to be sputtering.
- However, revival of arcing could be brought about from new aspects:

- Pulsed heat load accompanied with ELMs (Edge localized Modes)
- Surface morphology change due to plasma irradiation

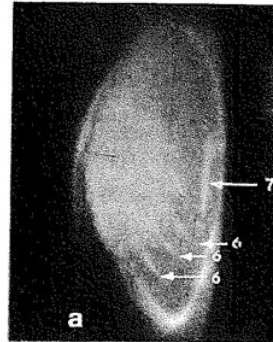

Luminescence from arc spot on limiter
R. Clausing *et al.* J. Nucl. Mater (1981)

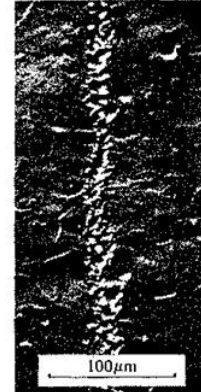

Arc track in the DITE tokamak.
McCracken *et al.* Nucl. Fusion (1978)

S.A. Grashin, et al. Fusion Engineering and Design 146 (2019) 2100–2104,,In a real tokamak conditions the combination of both the heat and particle fluxes is supposed to enhance tungsten damage and erosion. Different mechanisms of plasma-surface interaction can concentrate energy flux on a small surface area. One of such mechanisms could be the nonambipolar heat flux due to **the arcs and sparks**.”



Capillary arc discharge is an effective source of high-density plasmas

In this type of discharge, the confining medium is a small capillary made of glass or another dielectric (Teflon, polyethylene, alumina, BeO for example), typically with an inner diameter of 1 mm. This tube is in contact with two electrodes applying a fast current pulse (~ 1 kA over 100 ns). The plasma is formed by ablation of the capillary walls. The electron densities reached are also high ($10^{18} - 10^{19} \text{ cm}^{-3}$), and the temperatures are of a few eV [35, 90–92].

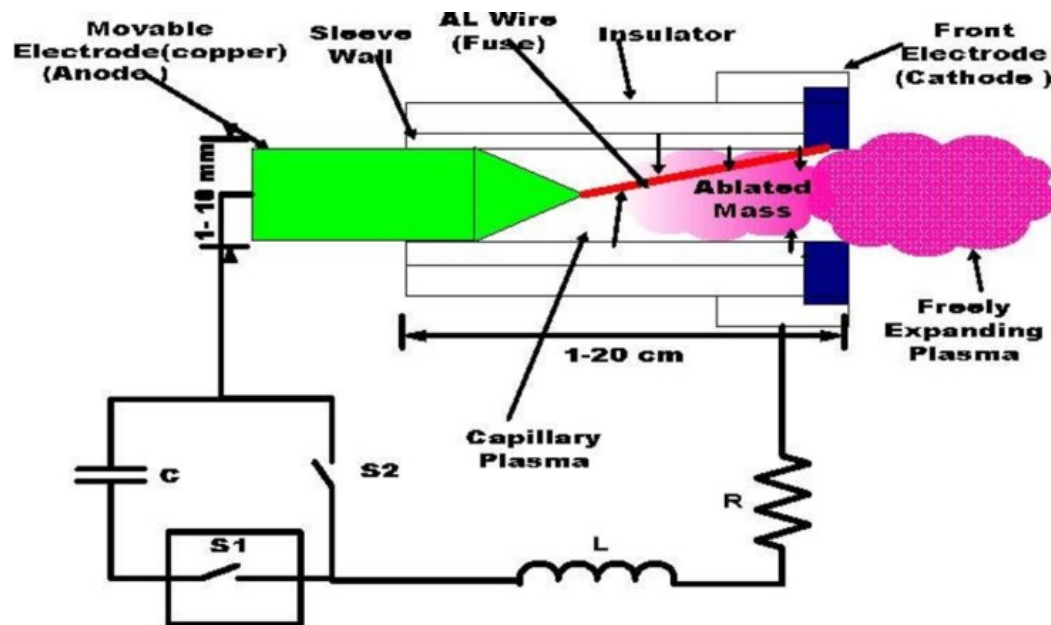

- US4759894A (1986): „the capillary walls comprise thermonuclear fusible material, the plasma temperature reaches at least **60 million degrees Kelvin**, and the density-time product is sufficient to produce a useful thermonuclear fusion reaction. The ultra-high temperature capillary discharge can be used as a pulsed source of nuclear and/or x-ray radiation or as a pulsed nuclear fusion reactor.“

-Capillary arc discharges have attracted attention as **promising laser sources at x-ray region**. For the realization of larger energy and shorter wavelength lasers with capillary discharges, understanding the pinching dynamics of plasmas is crucially important. *Eur. Phys. J. D* **54**, 377-382 (2009) “A few kA current was applied across the gas-filled alumina capillary (1 mm diameter and 8 mm long) to generate radiation in the EUV region (12–63 nm).“

-**Capillary lamps**: Owing to high pressure operation, at around **100 atmospheres**, it has a broad emission through the visible and UV spectrum. They are commonly employed in projection photolithography where their high concentration of rich UV radiation is especially valuable. They are also suited for photochemistry, fluorescent microscopy, microfilm enlargement, optical instrumentation, and other applications requiring high intensity ultraviolet radiation.

Power: 1000 W
Current: 1.25 to 1.60 A
Voltage: ~ 840 V
Rated life: 400-800 hours



Arc plasma torches

High temperature plasma jets up to some 50 000 K

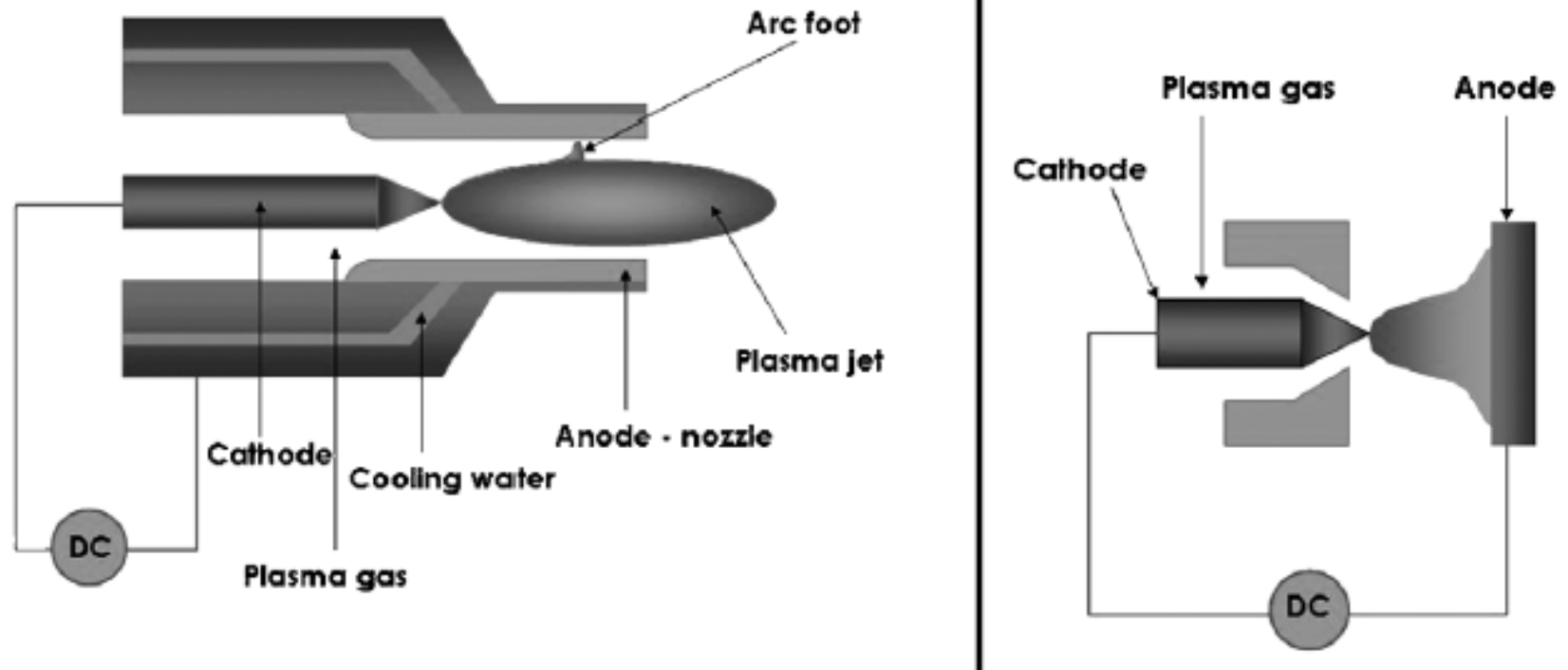
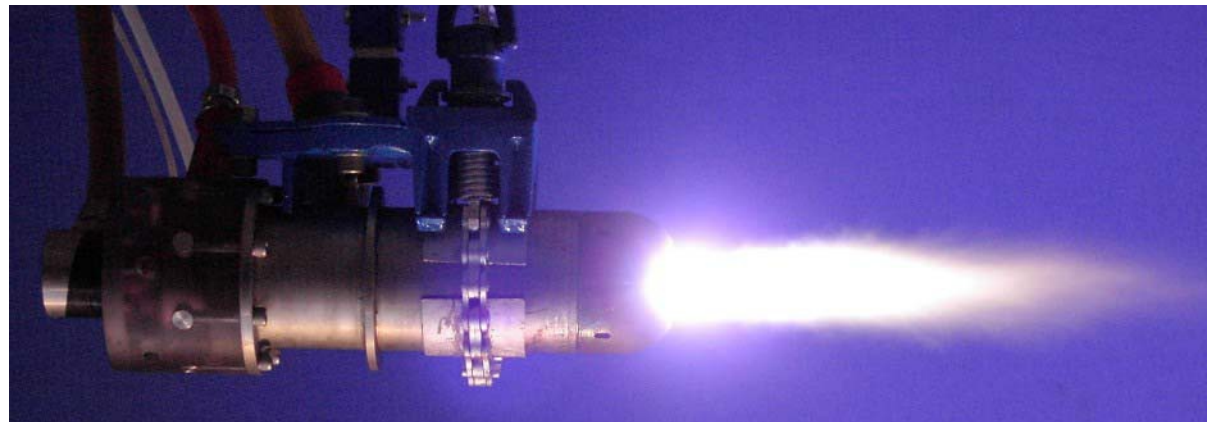
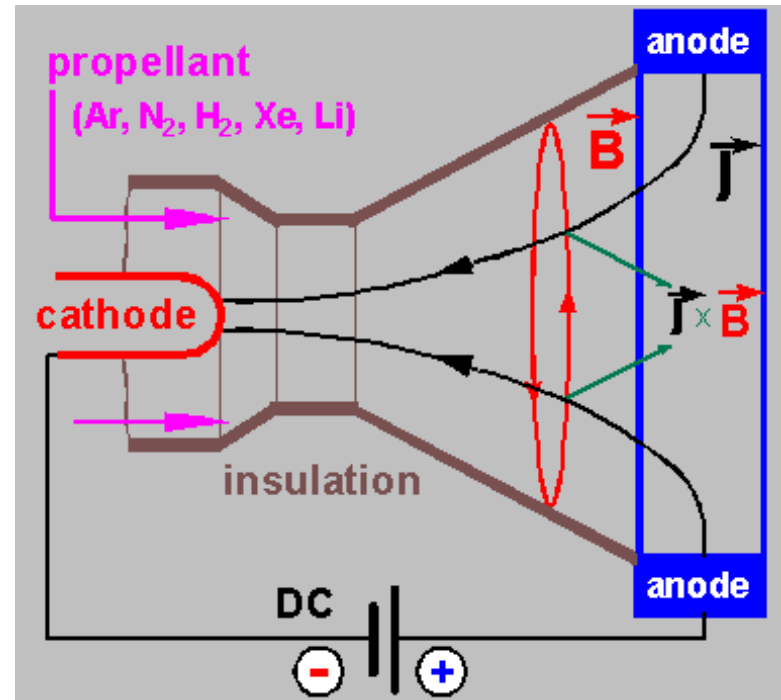
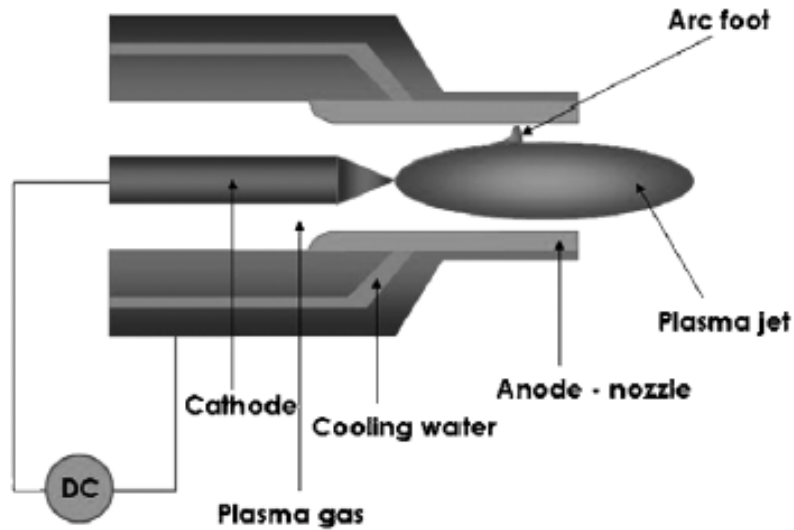

Fig. 4. Principle of arc plasma torches (left: current-carrying arc, right: transferred arc).

Own magnetic field of the arc B is pushing the plasma out from the anode nozzle resulting in the plasma jet



Arc plasma cutting

<https://www.open.edu/openlearn/science-maths-technology/engineering-technology/manupedia/plasma-arc-cutting>

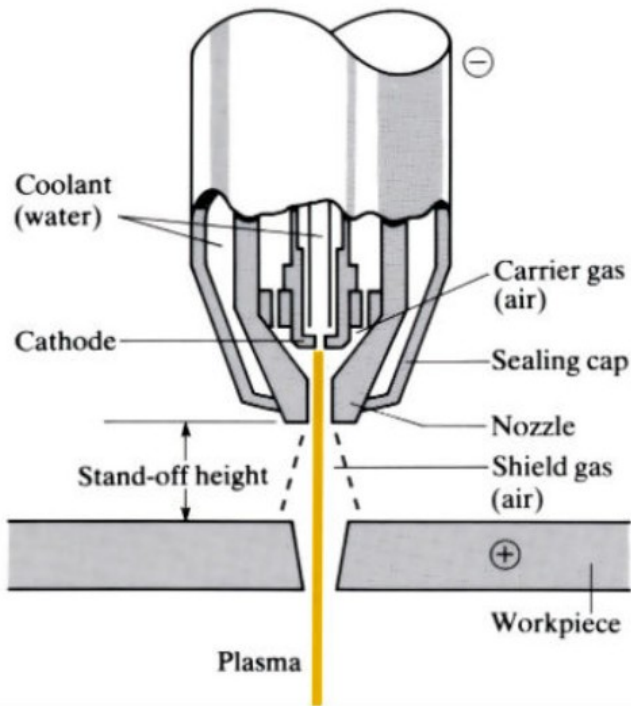

Arc plasma welding

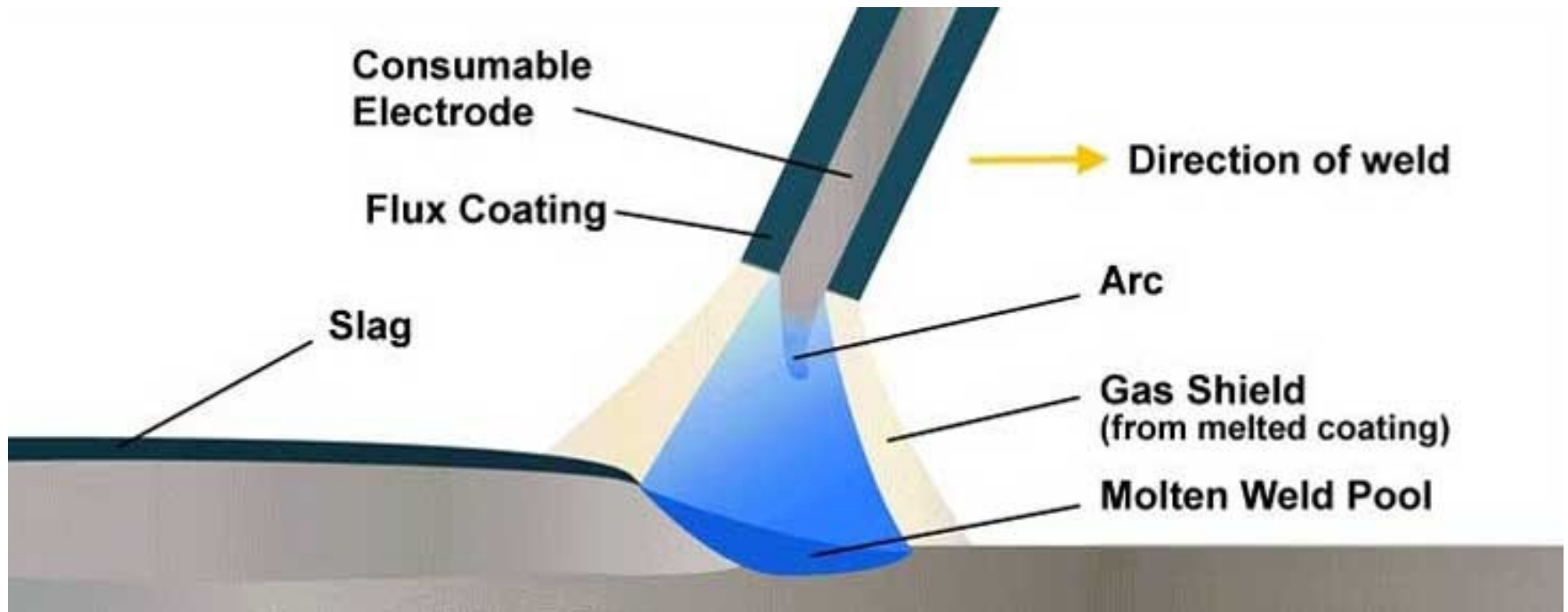

There are two types of plasma-arc welding process:

- ° In **the transferred-arc method** (Fig. a), the workpiece being welded is part of the electrical circuit. The plasma arc transfers from the electrode to the workpiece hence the term transferred.
- ° In **the non transferred method** (Fig. b), the arc occurs between the electrode and the nozzle, and the high temperature is carried to the workpiece by the plasma gas. This thermal energy-transfer mechanism is similar to that for an oxy-fuel.

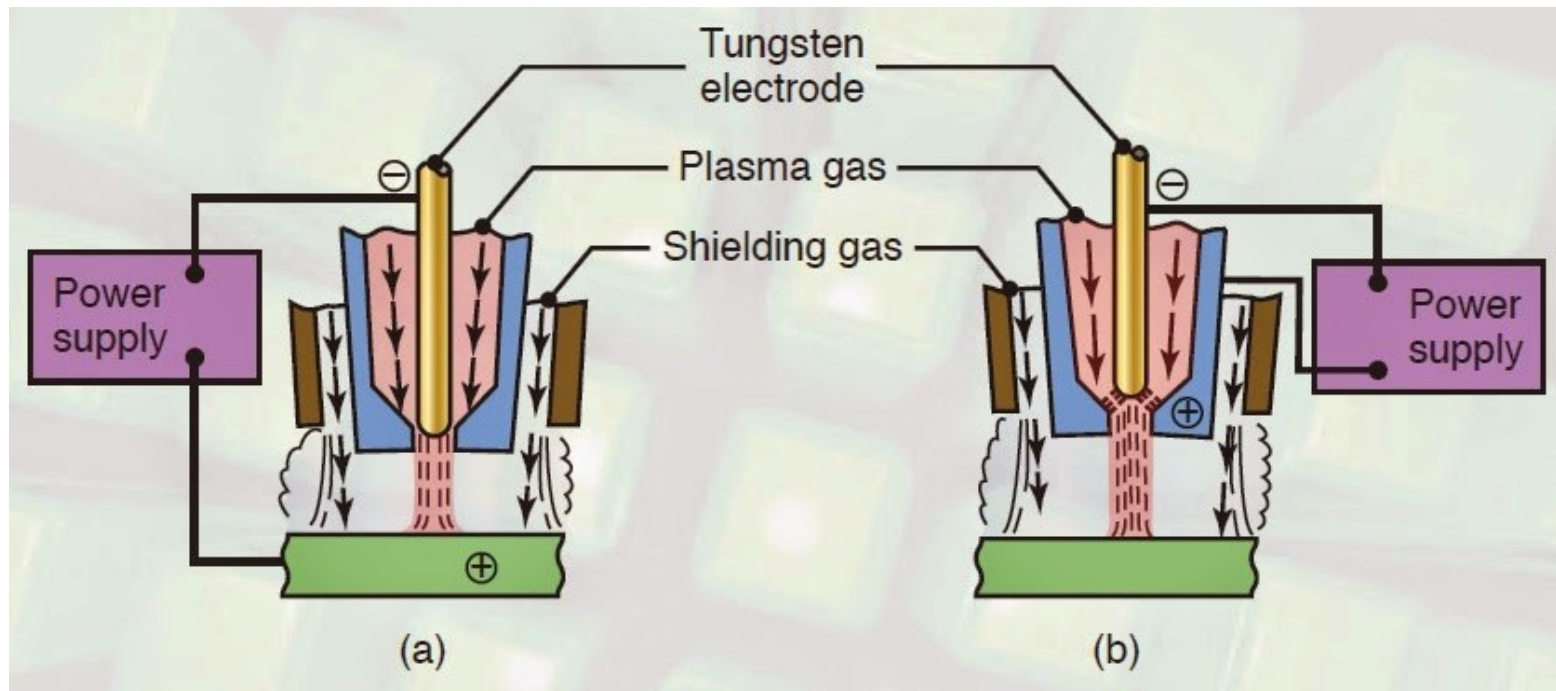

Hybrid water/argon-stabilized plasma (WSP-H) torch

Inst. of Plasma Physics, Prague

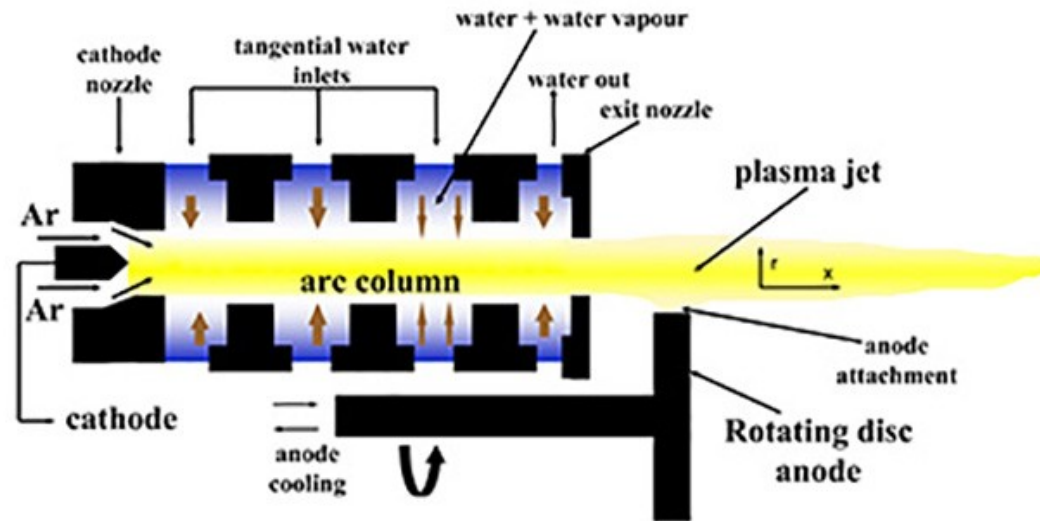

Enthalpy of WSP-H torch is more than order of magnitude higher than for conventional torches based on gas-stabilization.



<https://www.wsp-h.com/>

Plasma spraying

Free Standing Coatings

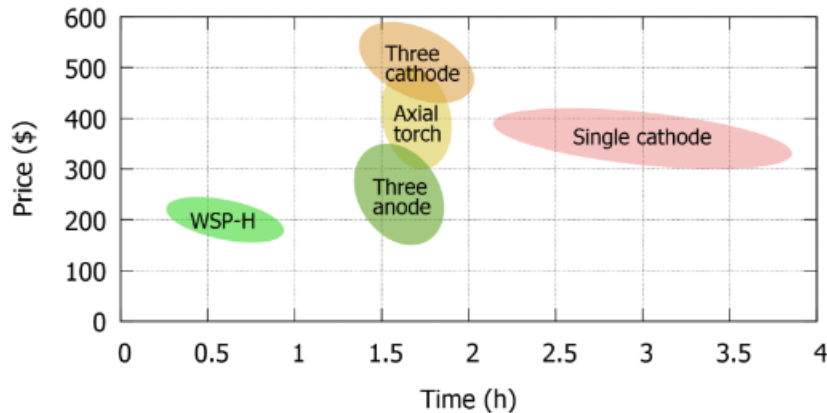
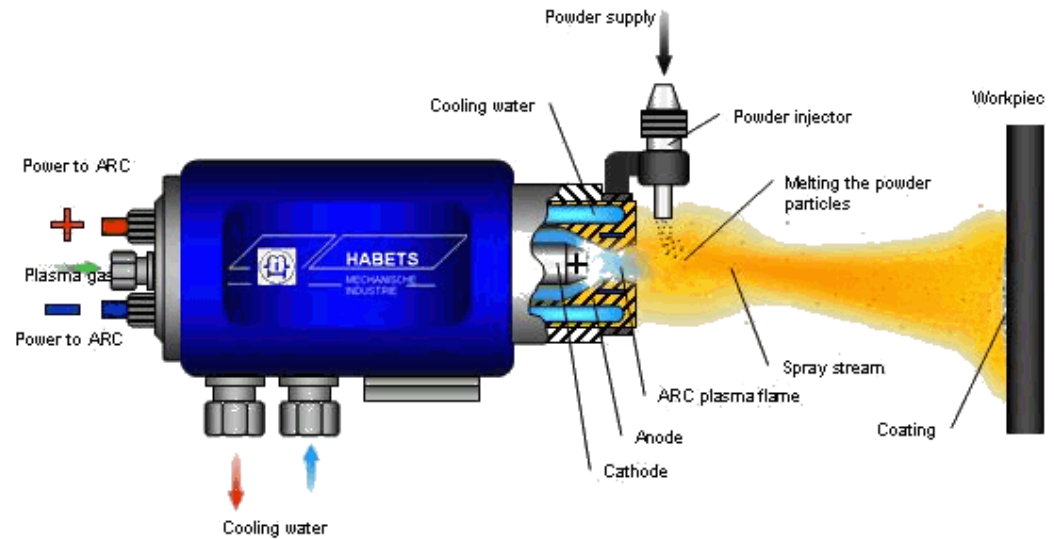

Rough comparison to other atmospheric plasma spraying systems (APS), when 10 kg of Al_2O_3 is deposited onto a part. The calculation takes into account the operational costs, torch deposition efficiency and consumed powder. 1 kg Al_2O_3 = \$15.

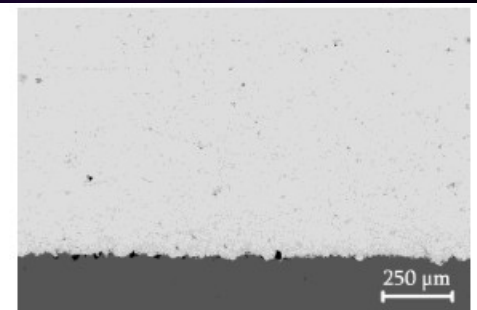
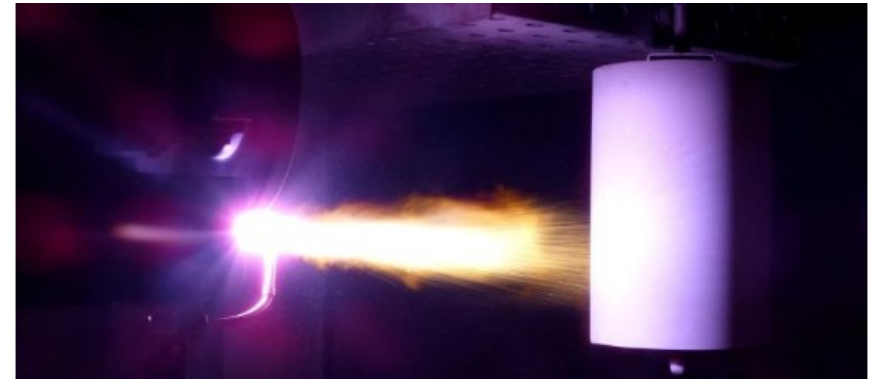

Tungsten deposited on steel (shrouded deposition)

Magnetoplasmadynamic thruster

https://en.wikipedia.org/wiki/Magnetoplasmadynamic_thruster



CGI rendering of Princeton University's lithium-fed self-field MPD thruster (from Popular Mechanics magazine)

The exhaust velocity range is beyond 110,000 m/s, triple the value of current Xenon based thrusters and **20 times better than liquid rockets**. Pulsed PT are generally considered the simplest form of electric spacecraft propulsion and were the first form of electric propulsion to be flown in space, having flown on two Soviet probes starting in 1964. PT generally flown on spacecraft **with a surplus of electricity from abundantly available solar energy**.

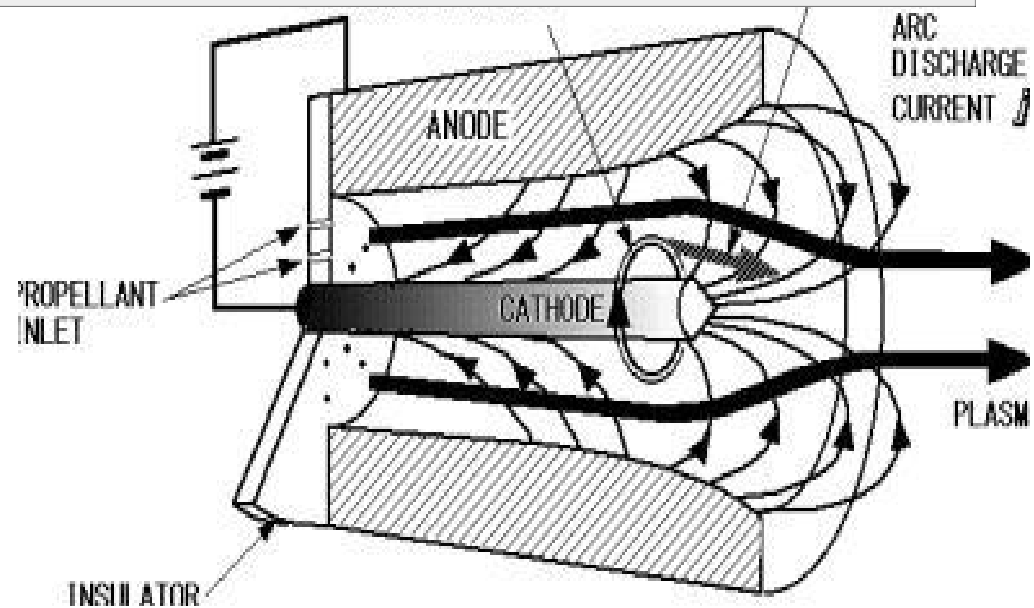
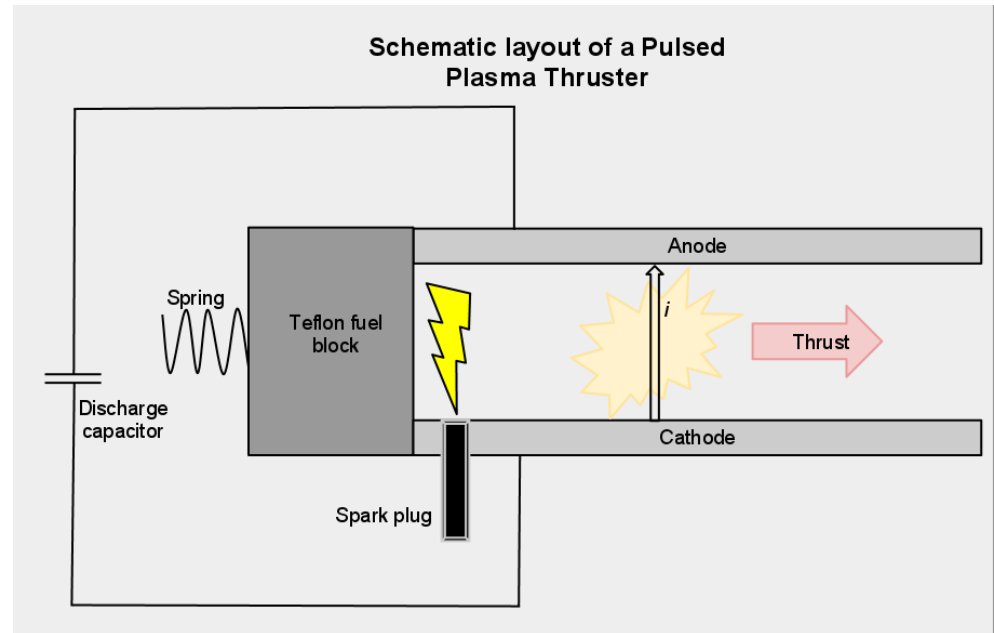

Spark discharge is a temporary arc discharge. The spark duration is restricted by the DC power supply characteristics.



Applications:

Spark gaps – HV switching:



„Spark-gap switches exist in many different configurations, but all rely on a conducting channel being formed in an electrode system. In its simplest form, a spark gap consists of two opposing electrodes placed in a gas (or liquid) medium. Once the voltage across the electrodes exceeds a certain threshold voltage a discharge is initiated in the gap. If this results in the complete breakdown of the gap a conducting channel is formed and the spark-gap switch is switched ‘on’. Once the conducting channel is quenched (when the voltage across the electrodes and the current through the channel fall below a certain threshold) the sparkgap switch is switched ‘off’ again. **The advantage of such switches is that they are capable of switching (extremely) high voltages at (extremely) high currents and in special configurations with subnanosecond rise times.** The disadvantage of the spark gap is that it typically requires maintenance (the electrodes erode), that an auxiliary gas- or liquid flushing and filtering system is required for high power operation and that the achievable repetition rates are limited because the medium in the gap has to recover before it can hold off the full voltage again.“

Also sub-nanosecond switching time for special radars

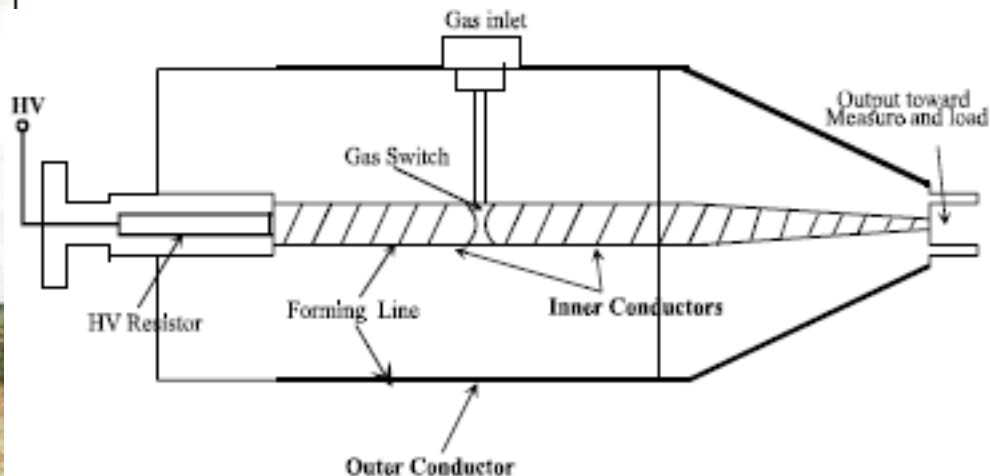
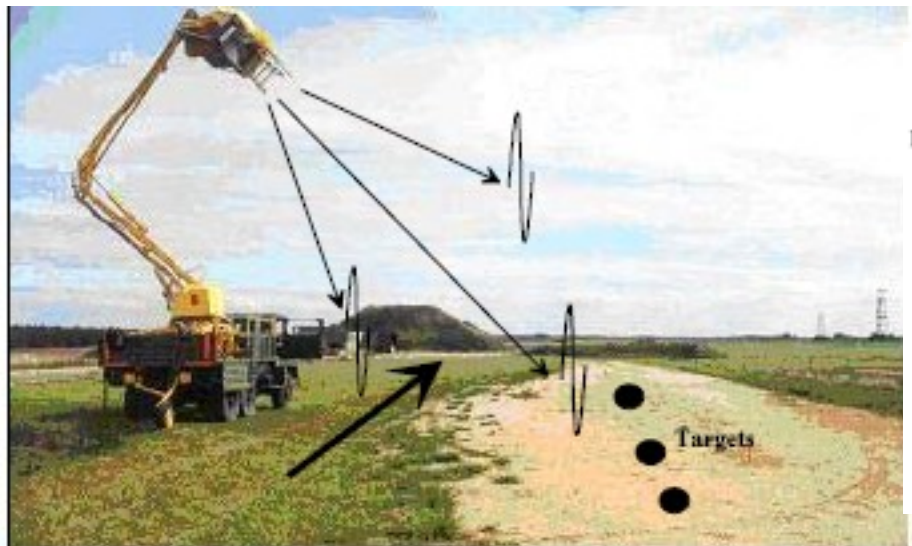

**High-pressure hydrogen-filled
Saprk gap:**

**$0.5 \text{ mm}/0.1 \text{ ns} = 5 \cdot 10^6 \text{ m/s}$
 $\text{Light velocity} = 300 \cdot 10^6 \text{ m/s}$**

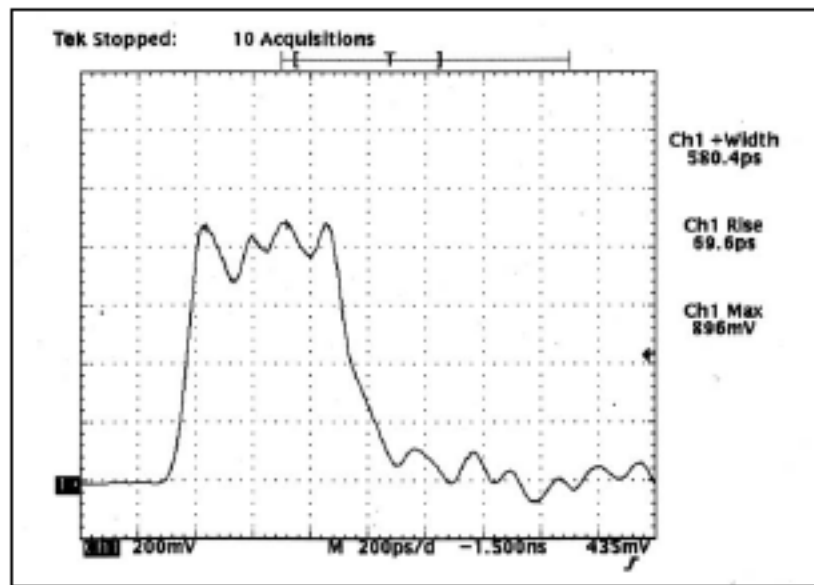
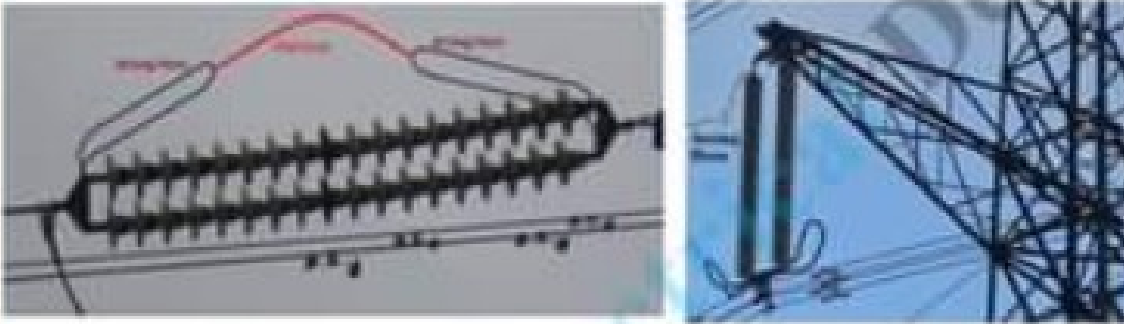

Figure 6. Output pulse shape of the coaxial generator ($P=55\text{bar}$, $d=0.45\text{mm}$, $\tau=68\text{ps}$, $V_{\text{OUT}}=26\text{kV}$)

Overvoltage protection

What is an Arcing Horn?



Arcing Horn protect the Insulators in High Voltage Transmission Line from flashover. Due to over voltages a flash over may take place which will shatter the Insulator. To prevent Insulator from such an occurrence, it is very important that flashover do not take place through the Insulator. Arcing Horn serves this purpose by providing a bypass flashover the high voltage across the insulator using air as a conductive medium.

When the voltage in a system, raised beyond its rated voltage, then it is known as overvoltage. Internal overvoltage has got their origin within the system itself, whereas external overvoltage is because of **lightning on the lines**. This over voltage may cause damage to insulators and substation equipment. It is, therefore, necessary to provide a means to protect the insulators and other apparatus from the harmful effect of overvoltage.

Circuit protection: Miniature spark gaps

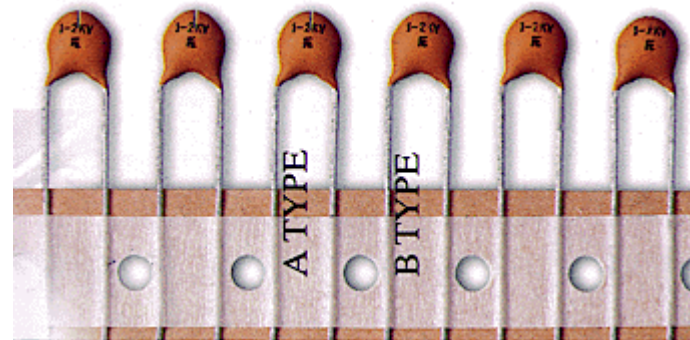

The lightning arrester protects the electrical equipment from lightning. It is placed very near to the equipment and when the lightning occurs the arrester diverts the high voltage wave of lightning to the ground

<https://circuitglobe.com/types-of-lightning-arresters.html>

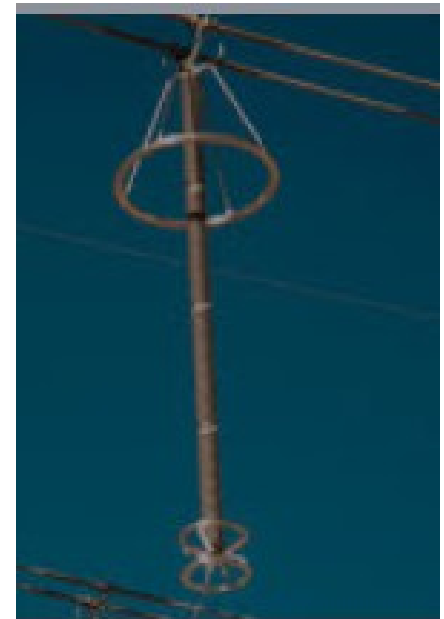
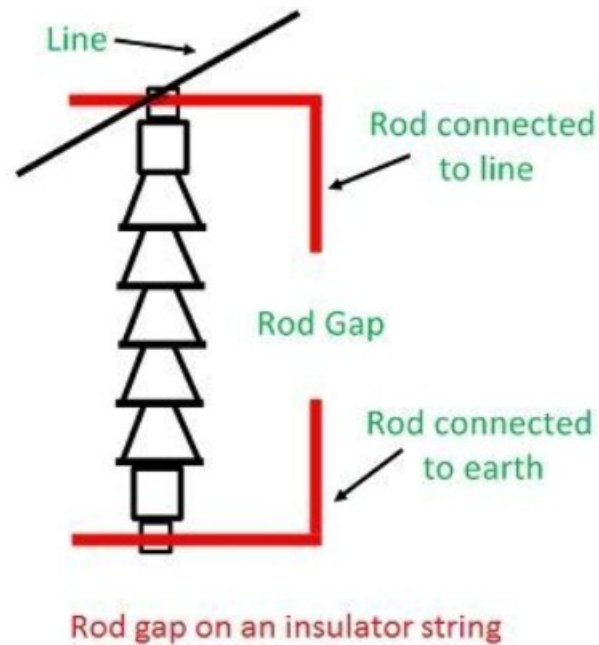

A trigatron is a type of triggerable spark gap switch designed for high current and high voltage (usually 10–100 kV and 20–100 kA, though devices in the mega-ampere range exist as well). It has very simple construction and in many cases is the lowest cost high energy switching option. A trigatron has three electrodes. The heavy main electrodes are for the high current switching path, and a smaller third electrode serves as the trigger. During normal operation, the voltage between the main electrodes is somewhat lower than the breakdown voltage corresponding to their distance and the dielectric between them (usually air, argon-oxygen, nitrogen, hydrogen, or sulfur hexafluoride). To switch the device, a high-voltage pulse is delivered to the triggering electrode. This ionizes the medium between it and one of the main electrodes, creating a spark which shortens the thickness of non-ionized medium between the electrodes.

<https://en.wikipedia.org/wiki/Trigatron>

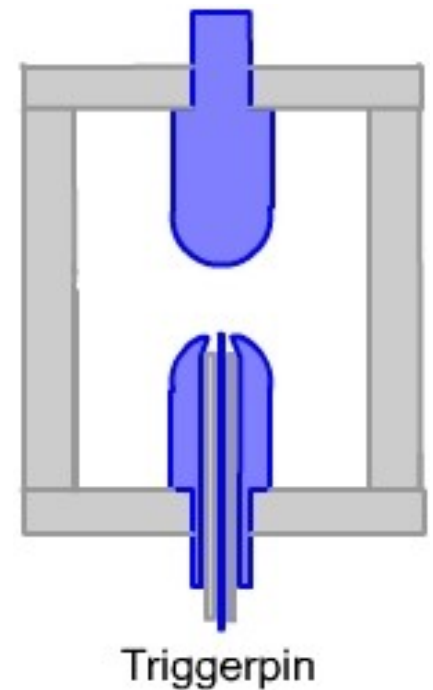

A spark plug is a device for delivering electric current from an ignition system to the combustion chamber of a spark-ignition engine to ignite the compressed fuel/air mixture by an electric spark, while containing combustion pressure within the engine:

https://en.wikipedia.org/wiki/Spark_plug

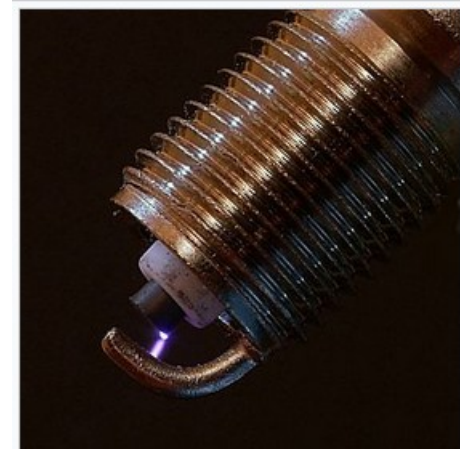

Is it the Townsend mechanism ???

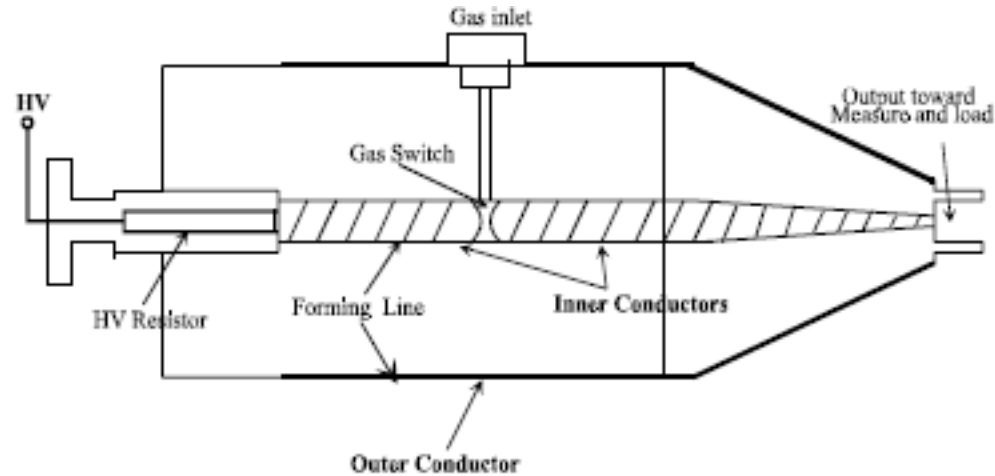
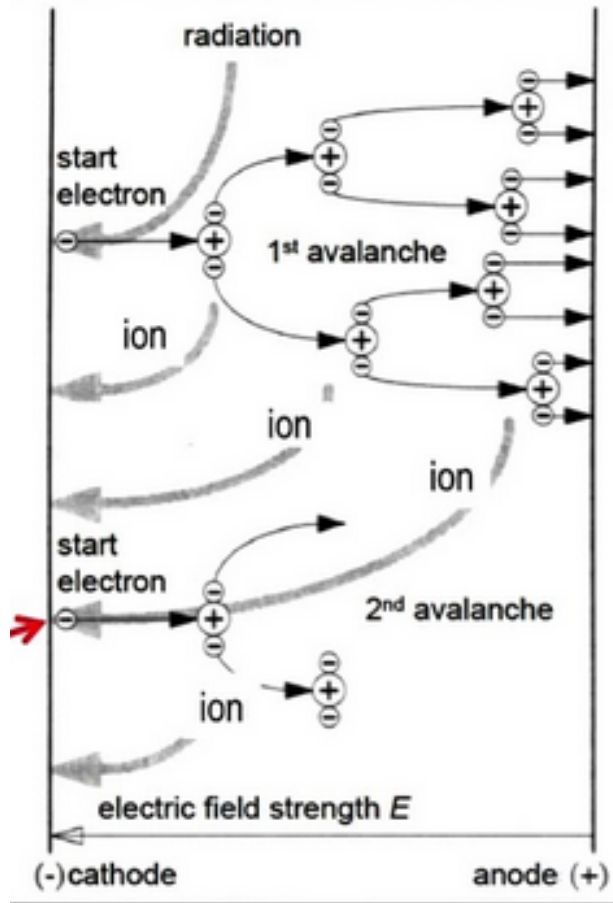

High-pressure hydrogen-filled spark gap:

$0.5 \text{ mm} / 0.1 \text{ ns} = 5 \cdot 10^6 \text{ m/s} ???$

Light velocity = $300 \cdot 10^6 \text{ m/s}$

Positive ion velocity $\sim 10^4 \text{ m/s}$

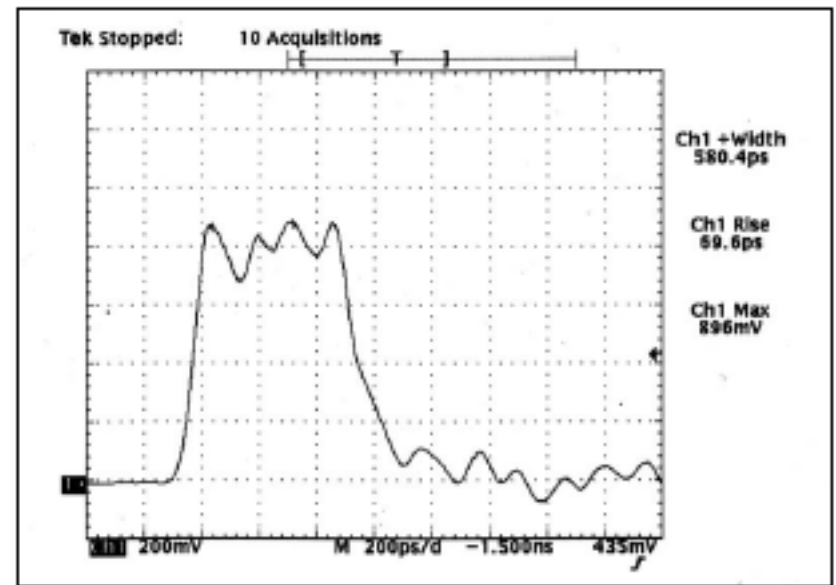
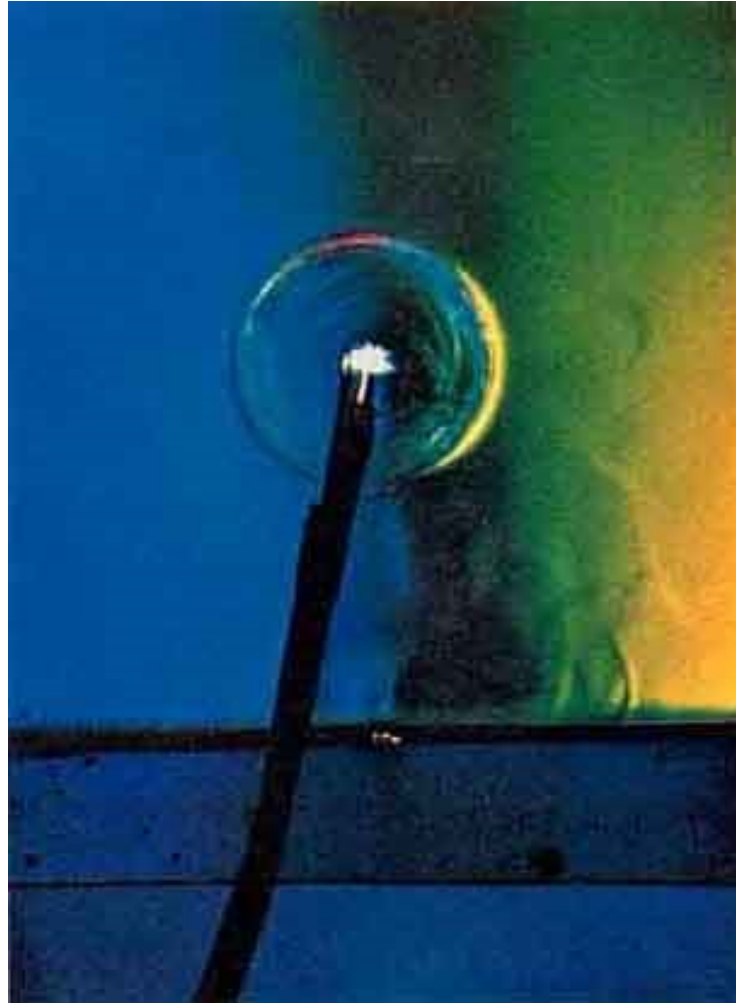
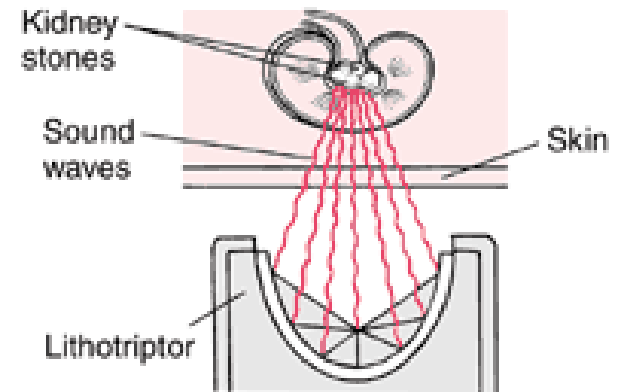
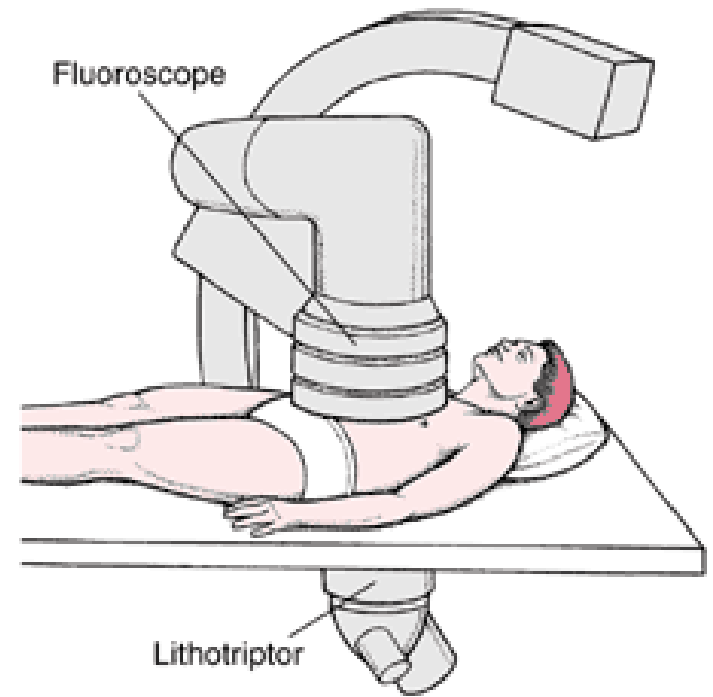
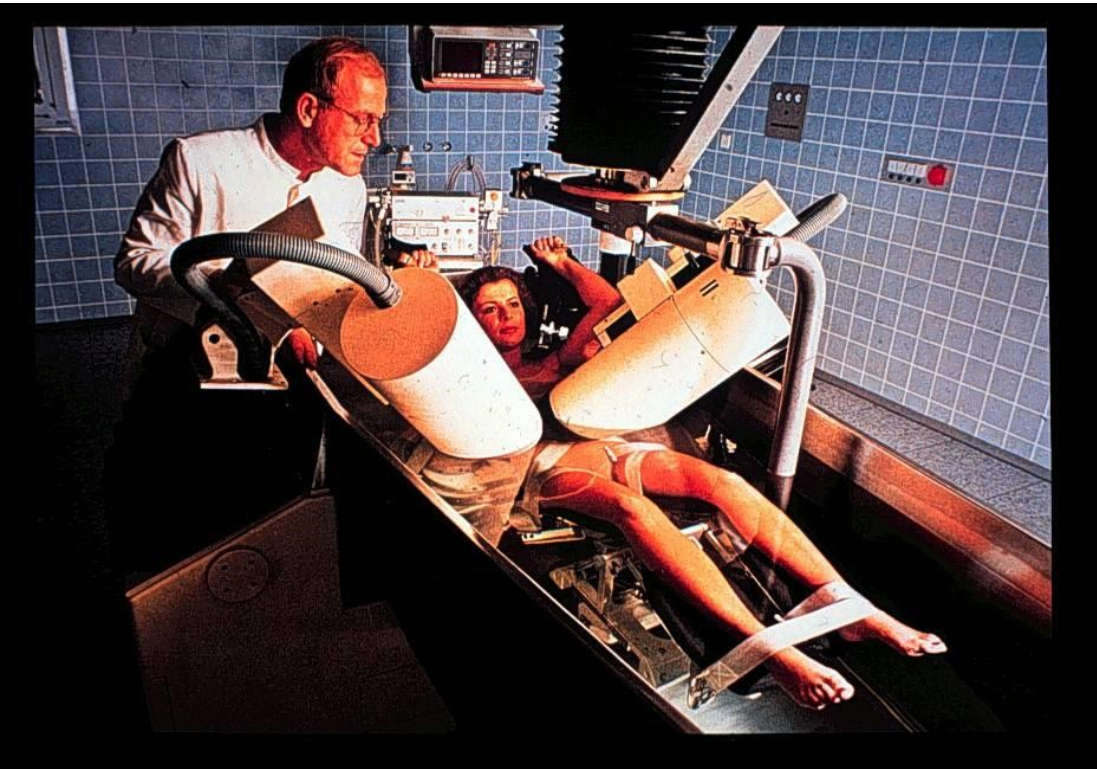

Figure 6. Output pulse shape of the coaxial generator ($P=55\text{bar}$, $d=0.45\text{mm}$, $\tau=68\text{ps}$, $V_{\text{OUT}}=26\text{kV}$)

Spark discharge generating shock waves in liquids –
sonars, lithotryptors, etc.



Lithotriptor



Shattering Kidney Stones

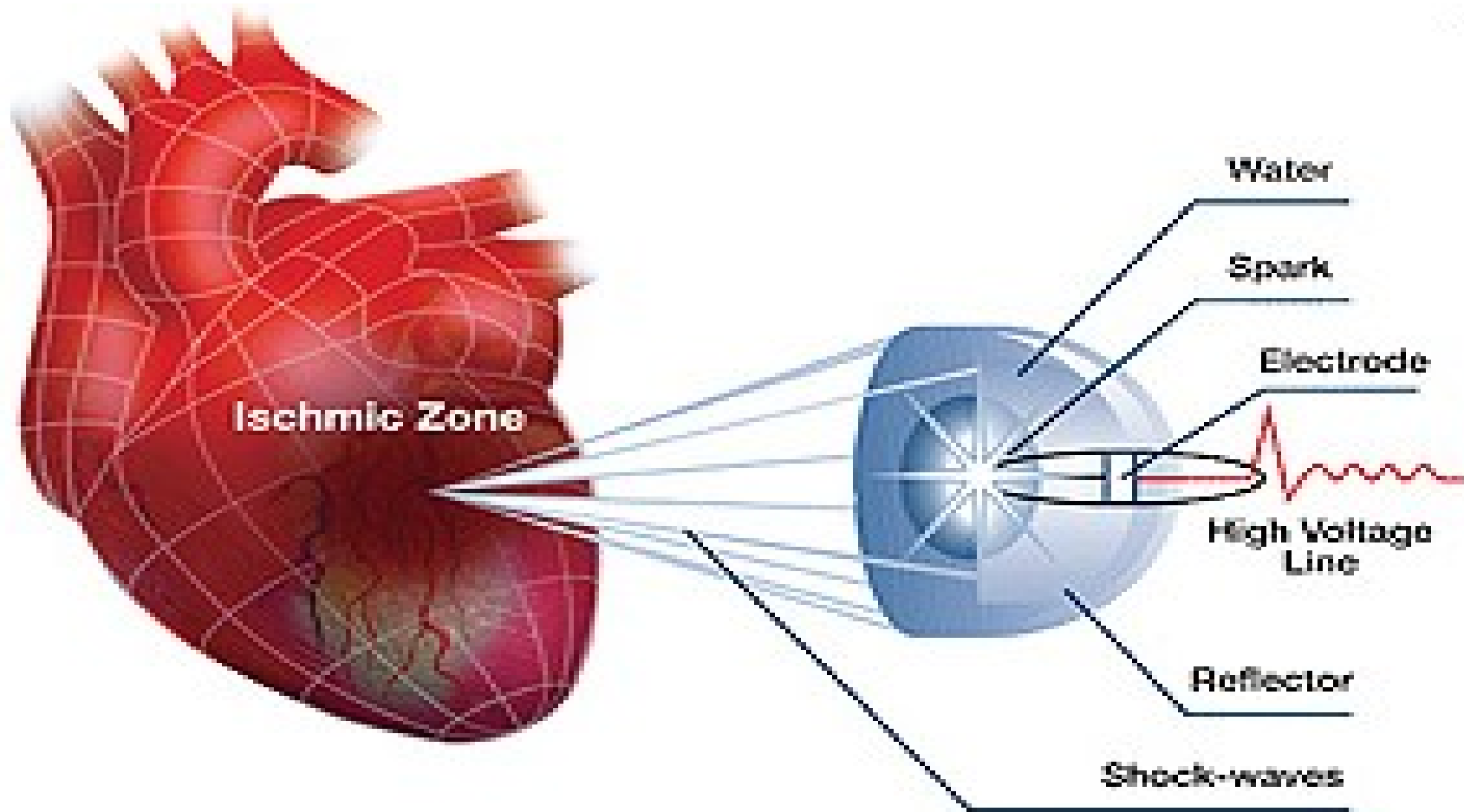

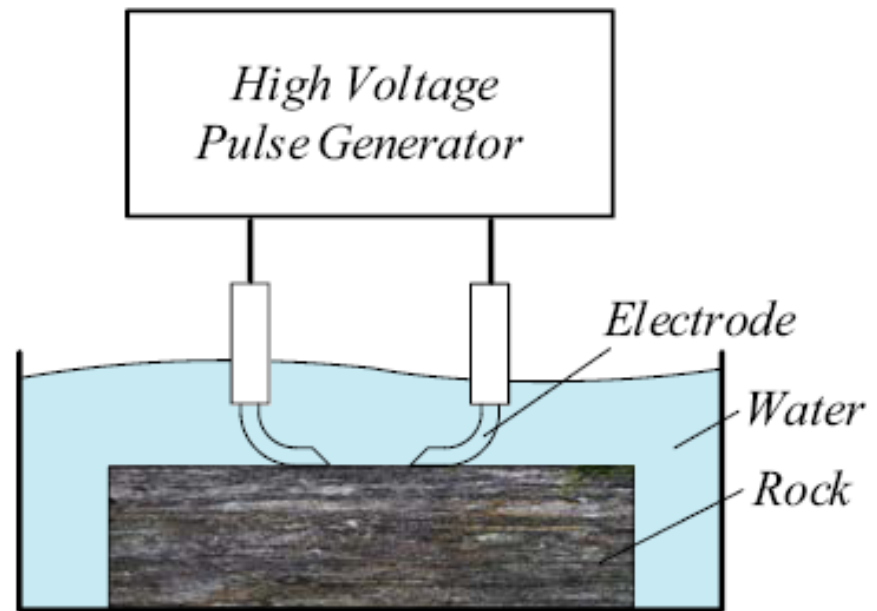
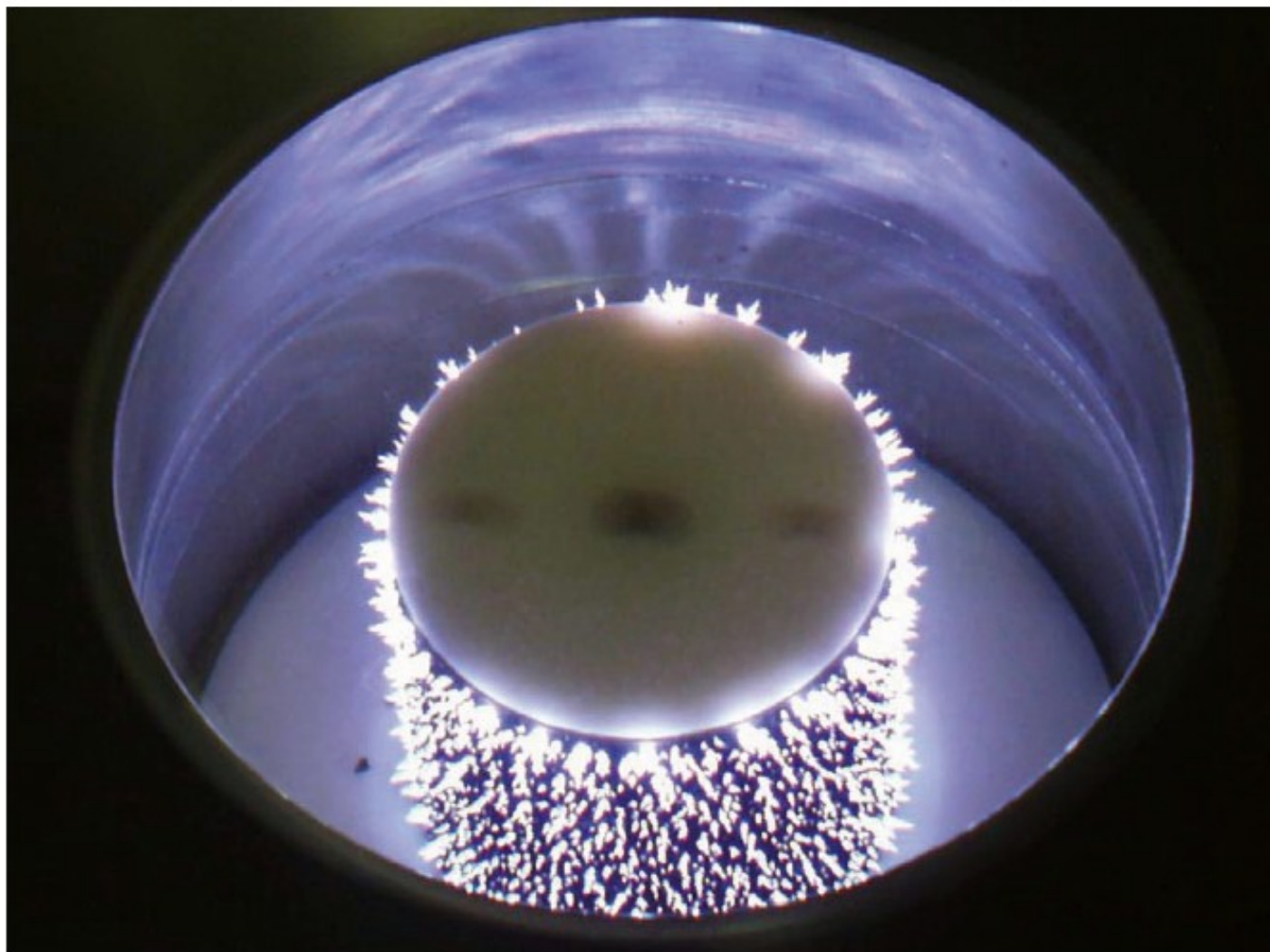

Figure 1: Basic setup for PCD-drilling consisting of a pulse modulator generating a high voltage and a high current pulse, two electrodes, a dielectric and the stone.



Obr 2 – Mnohokanálový vysokonapěťový elektrický výboj ve vodě generovaný s použitím kompozitní válcové elektrody



Plazmová elektrolytická oxidácia

(Vytváranie odolných oxidových vrstiev na povrchoch kovov hlavne Al, Mg – medicínske aplikácie)

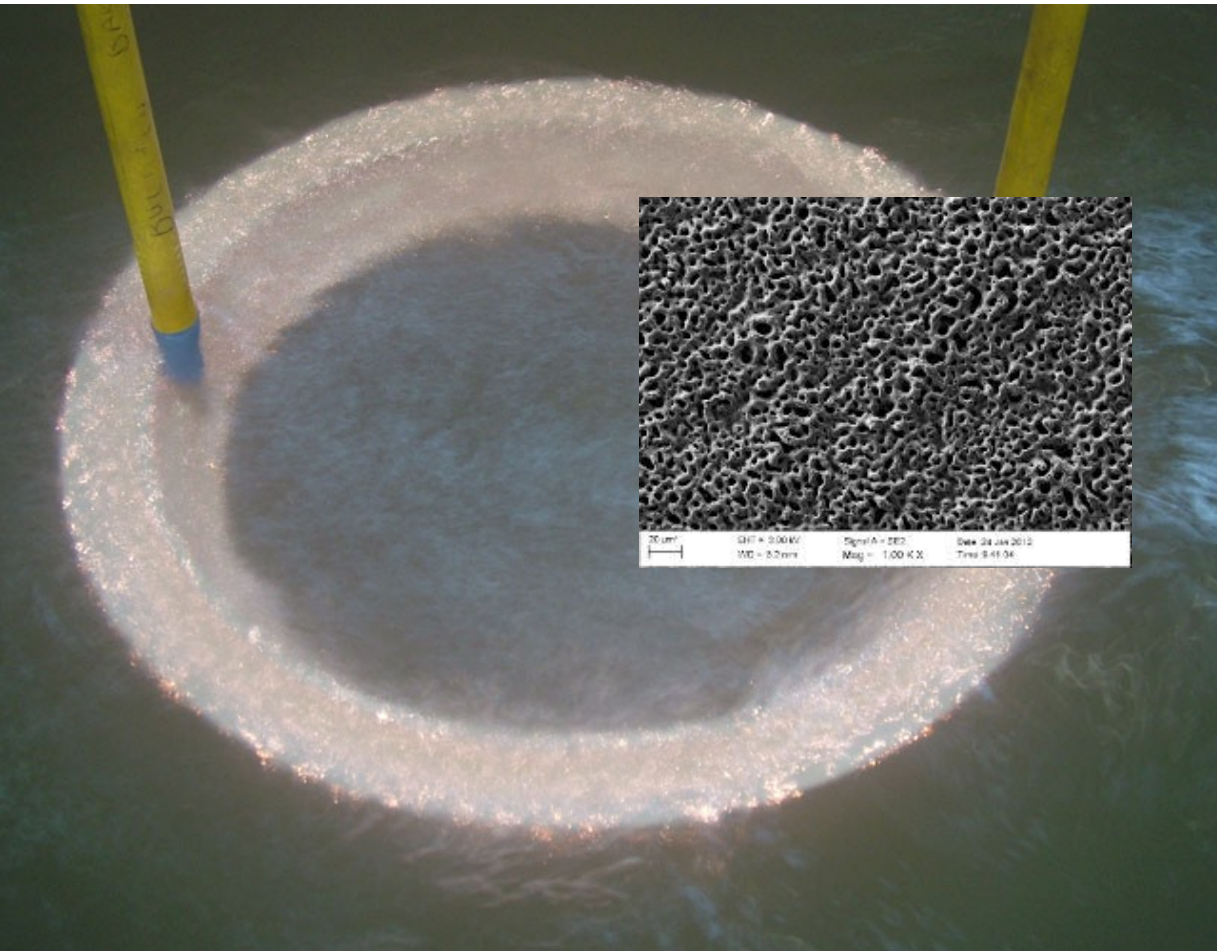

https://sfb1316.rub.de/index.php?option=com_chronoforms5&chronoform=CRCProjektListPublicView&ProjektID=14&TitleString=Project%20B5
https://www.google.com/search?q=plasma+electrolytic+oxidation&safe=active&sxsrf=ALeKk01PIKpWoJ0mFy0rtwKg7iaGIG-MsA:1615186870031&source=Inms&tbm=isch&sa=X&ved=2ahUKEwjL9Yj9j6DvAhW-wAIHHZJYBQIQ_AUoAXoECAcQAw&biw=1448&bih=762#imgsrc=uKz7Rbq2Rdi9hM

<https://blog.keronite.com/what-is-plasma-electrolytic-oxidation-article>

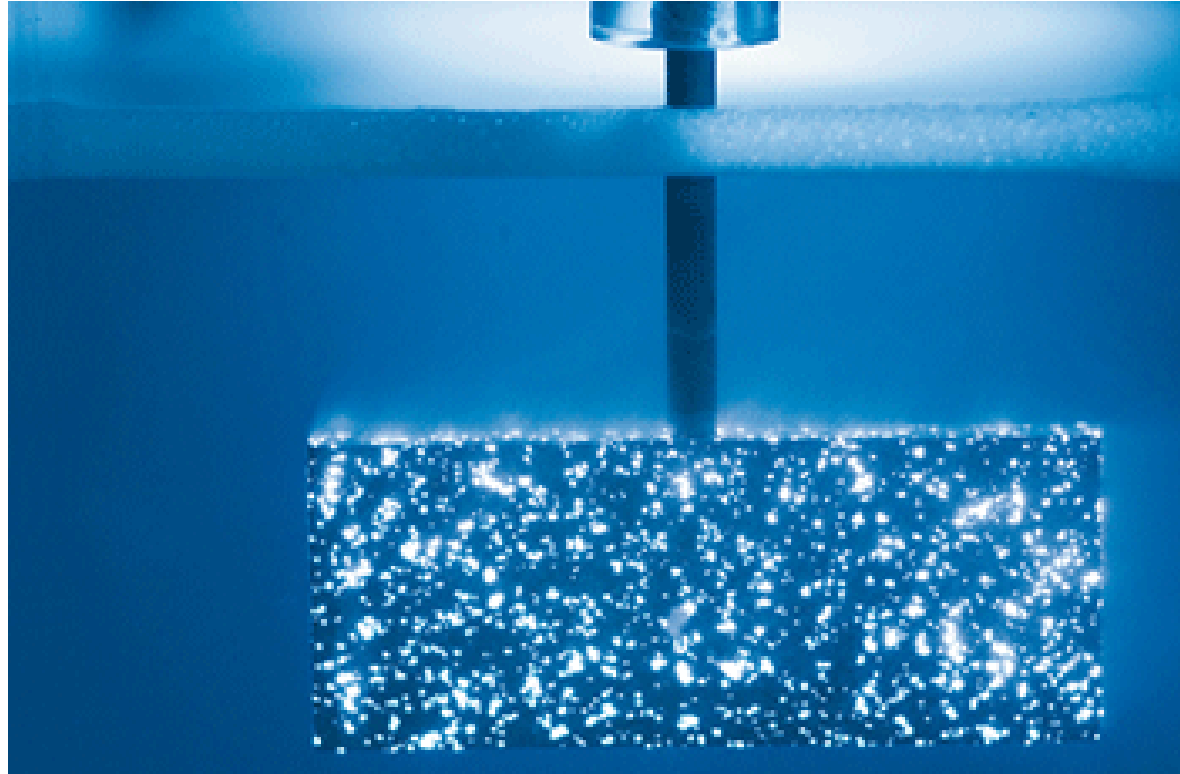
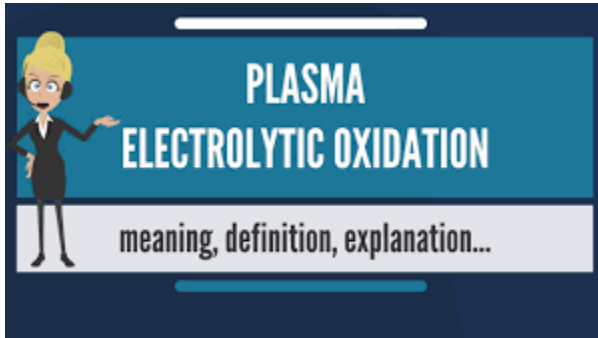

Electrical Discharge Masching

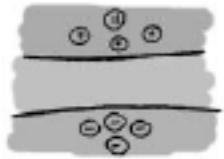

(a) Pre-breakdown :
voltage applied
between the electrode
and the workpiece

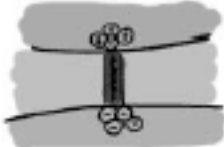

(b) Breakdown :
dielectric breakdown,
creation of the
plasma channel

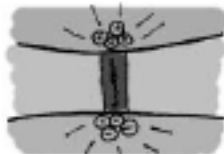

(c) Discharge :
heating, melting and
vaporizing of the
workpiece material



(d) End of the discharge :
plasma implosion,
removing of the
molten metal pool



(e) Post-discharge :
solidifying and flushing
of the eroded particles
by the dielectric

