

# Bi9393 Analytická cytometrie

## Lekce 3



**Karel Souček, Ph.D.**

Oddělení cytokinetiky  
Biofyzikální ústav AVČR, v.v.i  
Královopolská 135  
612 65 Brno

**e-mail: [ksoucek@ibp.cz](mailto:ksoucek@ibp.cz)**  
tel.: 541 517 166

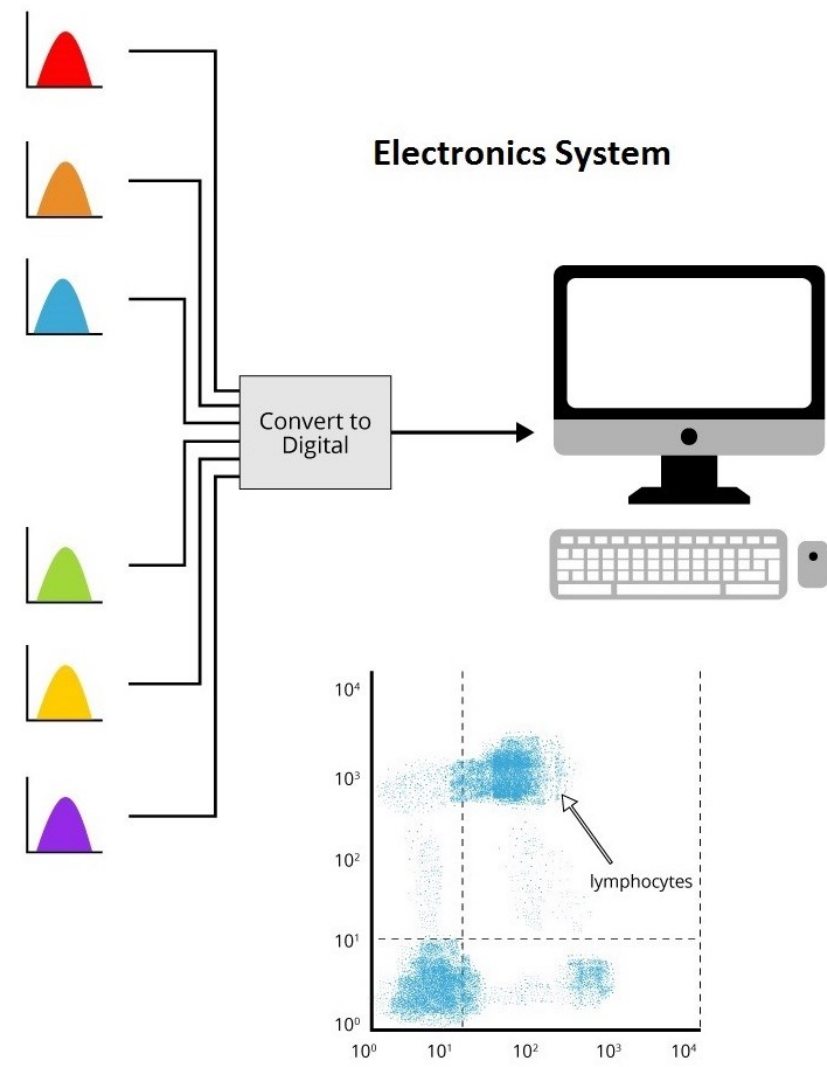
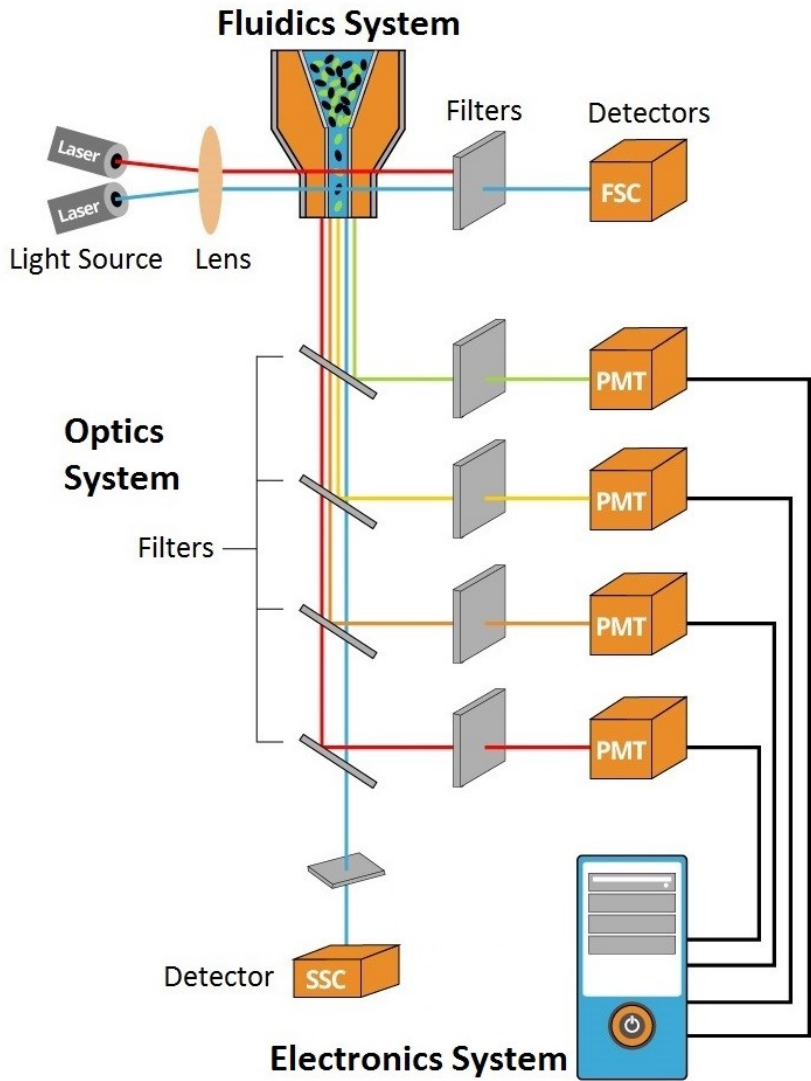



# Průtokové systémy a hydrodynamika

Getting the cells in the right place (at the right time)! (Shapiro, pp 133-143 - 3rd ed)

## Průtoková cytometr:

Pomocí hydrodynamicky zaostřeného fluidního systému analyzuje buňky v zaostřeném světelném paprsku (laseru).

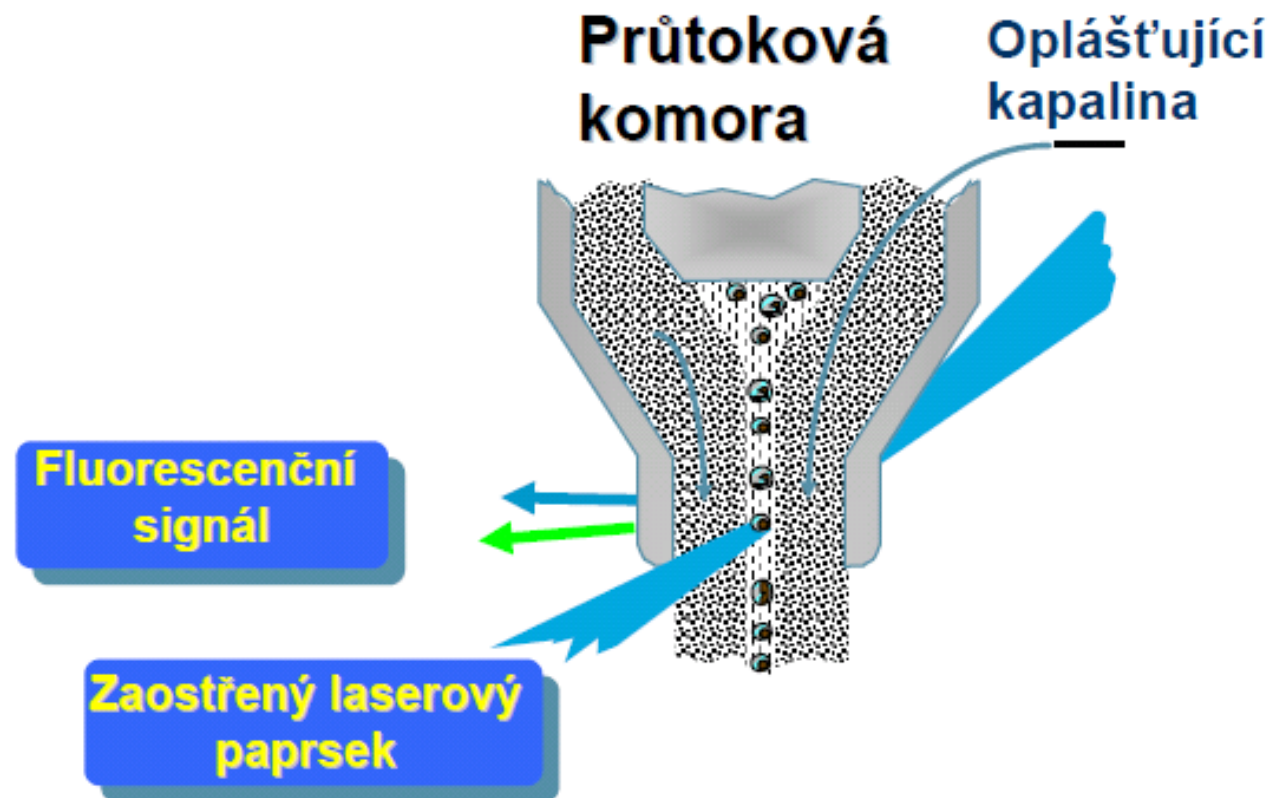

# Fluidní systém: BD FACSAria II

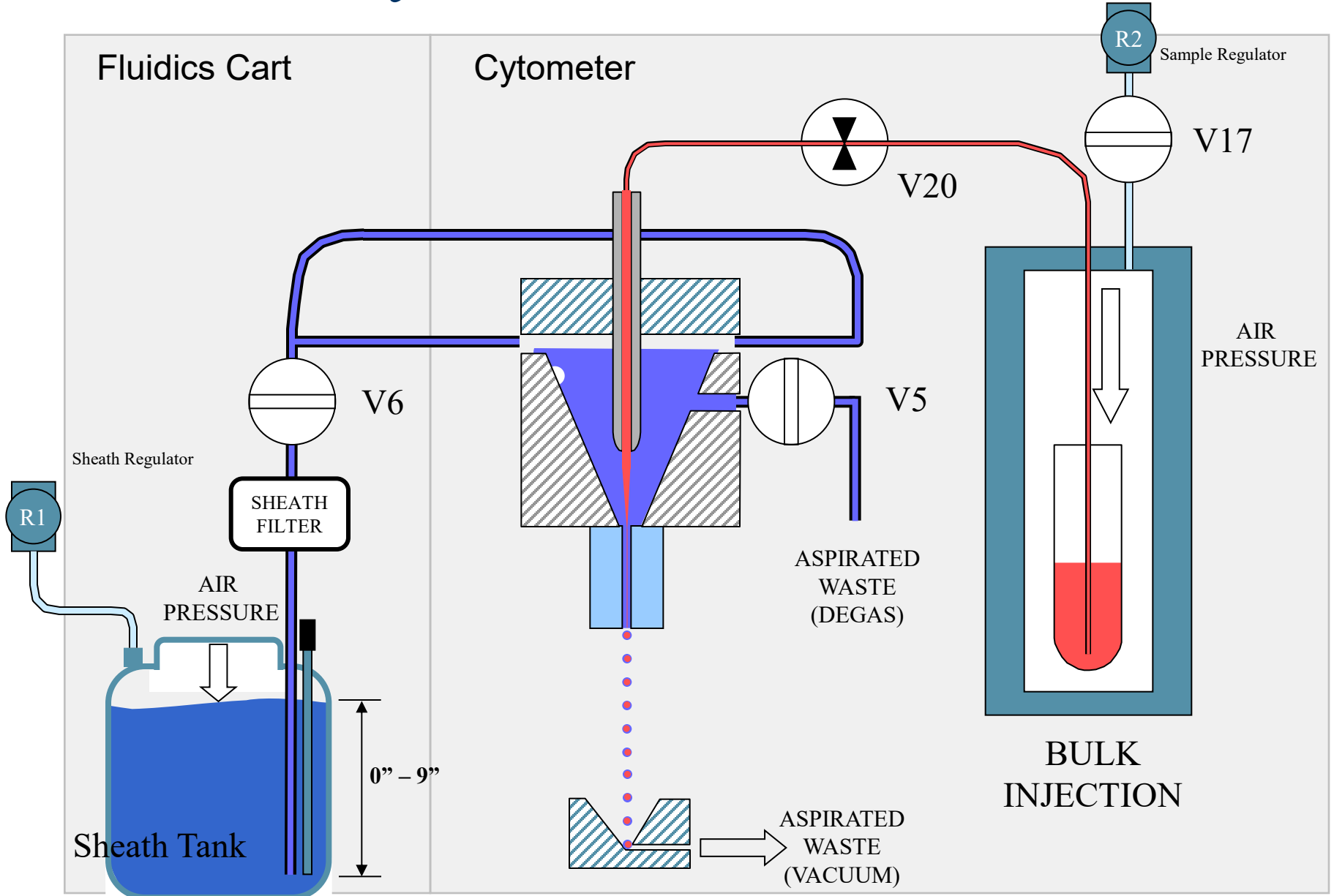

# Hydrodynamic focussing in the cuvette

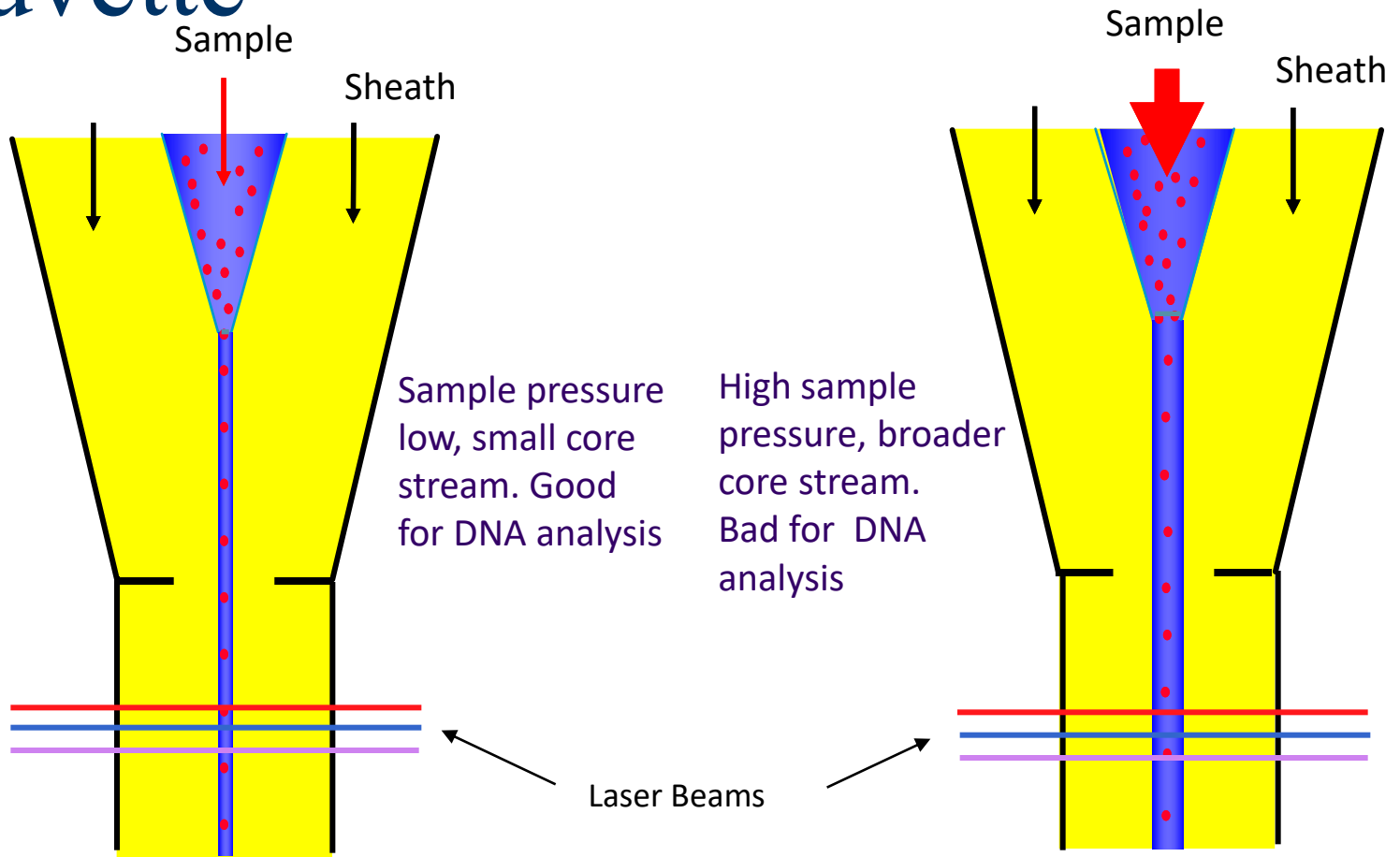

# Fluidní systém

## Pozitivní tlakový systém

- založen na rozdílném tlaku mezi nosnou kapalinou a vzorkem
- vyžaduje zdroj vyrovnaného tlaku (vzduch, dusík)
- rychlost průtoku mezi 6-10 m/s

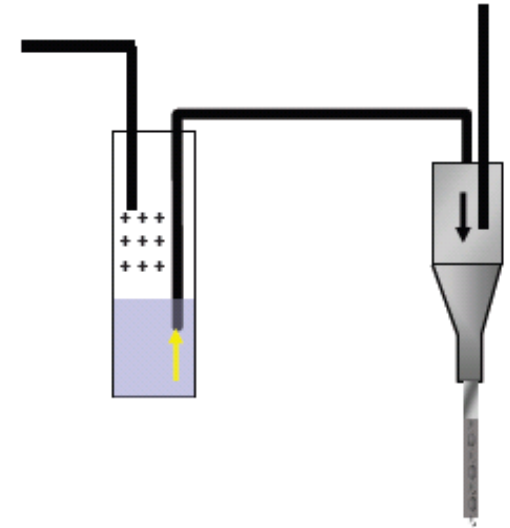

## Pozitivní vytlačování injekční systém

- průtok 1-2 m/s
- fixní objem (50  $\mu$ l, 100  $\mu$ l)
- možnost určení absolutních počtů buněk

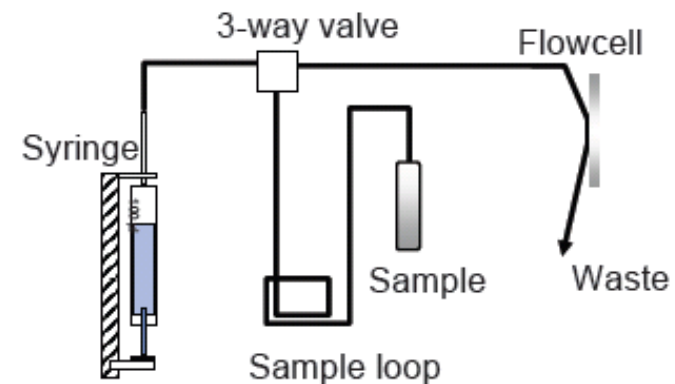



# Hydrodynamický a fluidní systém

- buňky jsou vždy v suspenzi
- vzorek je obvykle ve fyziologickém roztoku
- nosná kapalina je voda nebo fyziologický roztok
- nosná kapalina pro sortování musí být fyziologický roztok
- vzorky jsou hnány tlakem nebo pomocí pístu





# Fluidika

- potřebujeme buňky v suspenzi, protékající v jednom sloupci napříč osvětleným místem
- u většiny zařízení je toho dosaženo injekcí vzorku do proudu nosné kapaliny skrz malý otvor (50-300  $\mu\text{m}$ )



# Fluidika

- Pokud jsou podmínky optimální pak vzorek proudí středem bez směšování s nosnou kapalinou
- takový stav nazýváme laminární proudění (**laminar flow**)

# Fluidika - Laminární vs. turbulentní proudění

- **Turbulentní** proudění je charakteristické chaotickými (stochastickými) změnami
- **Laminární** proudění – kapalina proudí v paralelních vrstvách které se vzájemně nemísí



wikipedia.org

# Fluidika - Laminární vs. turbulentní proudění

- Osborne Reynolds (1842 -1912) definoval podmínky laminárního proudění (1883)



"[http://en.wikipedia.org/wiki/Osborne\\_Reynolds](http://en.wikipedia.org/wiki/Osborne_Reynolds)"

# Fluidika - Laminární proudění

- Zda bude průtok laminární je možné určit pomocí **Reynoldova čísla**

$$Re = \frac{d\rho\bar{v}}{\eta} \quad \text{where}$$

$d$  = tube diameter  
 $\rho$  = density of fluid  
 $\bar{v}$  = mean velocity of fluid  
 $\eta$  = viscosity of fluid

- když  $Re < 2300$ , průtok je vždy **laminární** (v trubici)
- $Re > 2300$ , průtok může být **turbulentní**



# Fluidika

- Zavedení malého objemu kapaliny do velkého způsobem, kdy se stává „zaostřeným“ ve směru toku, nazýváme **hydrodynamické zaostřování**.

APPLIED MICROBIOLOGY, Sept. 1972, p. 384-388  
Copyright © 1972 American Society for Microbiology

Vol. 24, No. 3  
Printed in U.S.A.

## Hydrodynamic Focusing and Electronic Cell-Sizing Techniques

M. L. SHULER, R. ARIS, AND H. M. TSUCHIYA

*Department of Microbiology, Department of Chemical Engineering and Materials Science, University of Minnesota, Minneapolis, Minnesota 55455*

Received for publication 24 May 1972

The technique of hydrodynamic focusing, used to improve the resolution of the Coulter counter for the sizing of bacteria, was examined. Latex particles of  $0.26 \mu\text{m}^3$  to  $6.7 \mu\text{m}^3$  volume were used to examine the characteristics of the system with and without hydrodynamic focusing. The system then was evaluated for sizing mixed bacterial populations as well as single populations. Possible applications are also discussed.



# Fluidika – orientace a deformace částic

- Během hydrodynamického ostření jsou buňky vystaveny třecímu stresu na různých místech jejich povrchu.
- Tření způsobuje jejich orientaci delším koncem ve směru proudění.
- Stres může také způsobit jejich deformaci.



# Fluidika – průtokové komory

## ■ Průtokové komory

- Určují osu a velikost průtoku nosné kapaliny a vzorku
- Vymezují místo pro hydrodynamické zaostření
- Slouží také jako místo kde dochází k ozáření buněk zdrojem světla



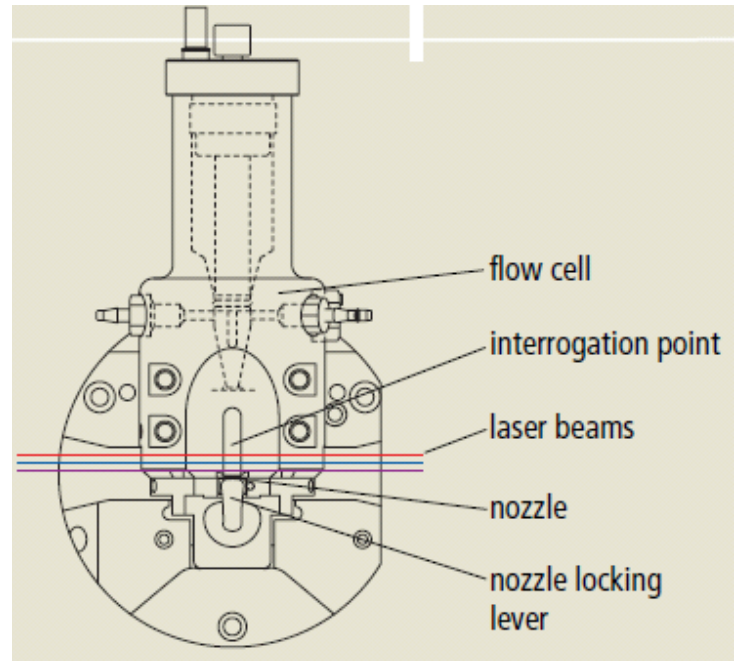
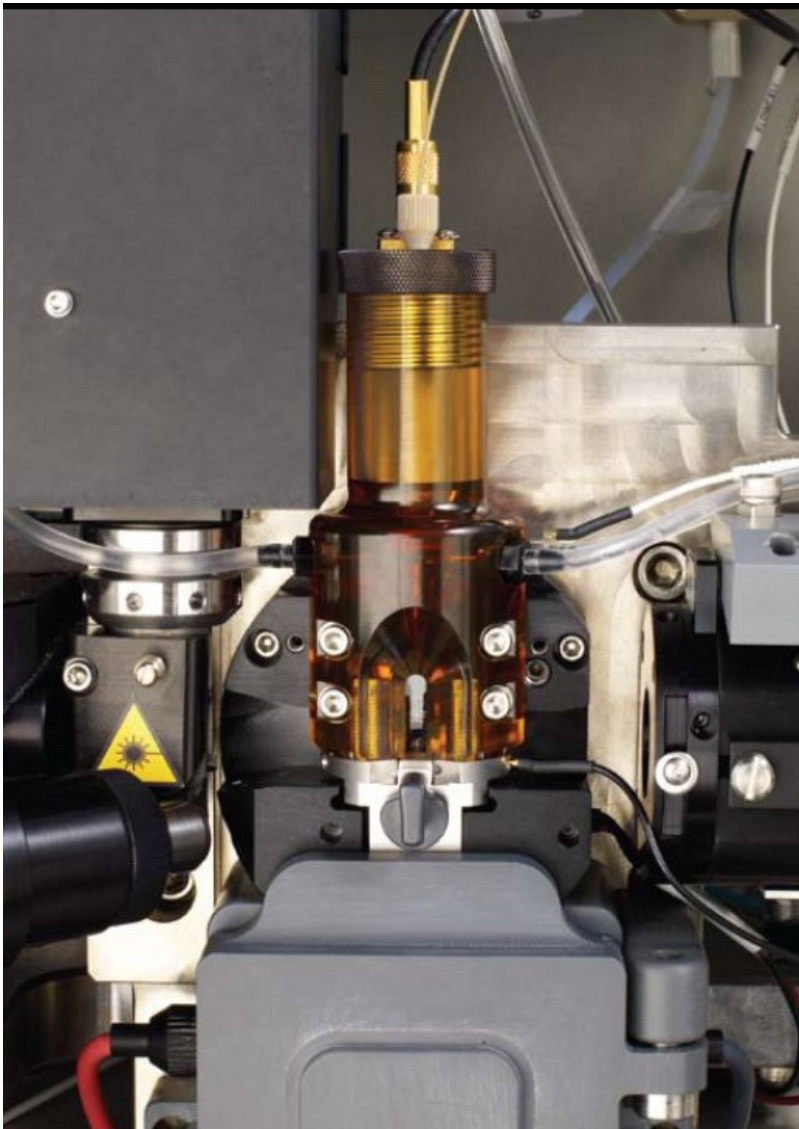

## BD FACSaria II

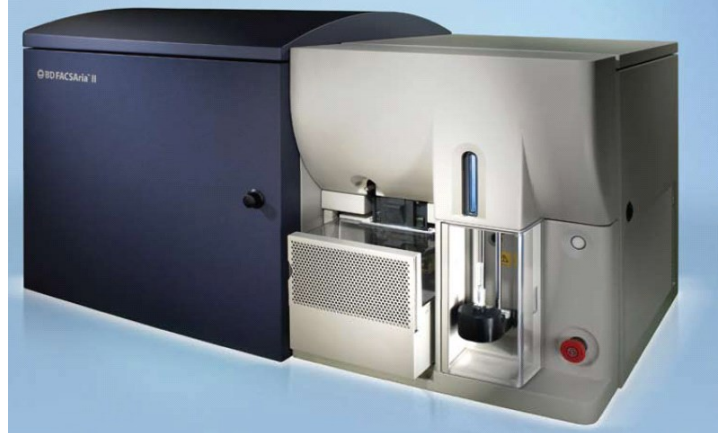



# Fluidika – průtokové komory

## Základní typy průtokových komor

### – **Jet-in-air**

- Nejlepší pro sortování, horší optické vlastnosti

### – **Flow-through cuvette**

- Výborné optické vlastnosti, může být použita pro sortování

### – **Closed cross flow**

- Nejlepší optické charakteristiky, nelze sortovat

### – **Open flow across surface**

- Nejlepší optické charakteristiky, nelze sortovat

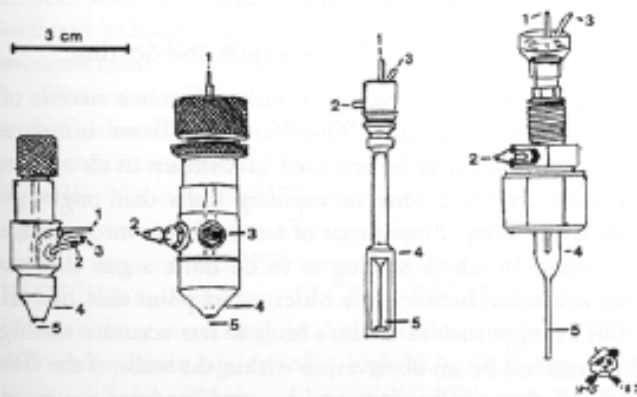
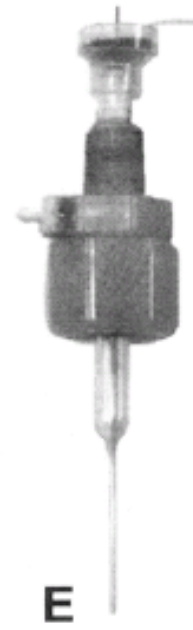

# Particle Delivery: Hydrodynamic Focusing

Conventional Instrumentation: **Low Flow Rates (12 $\mu$ L/min)**

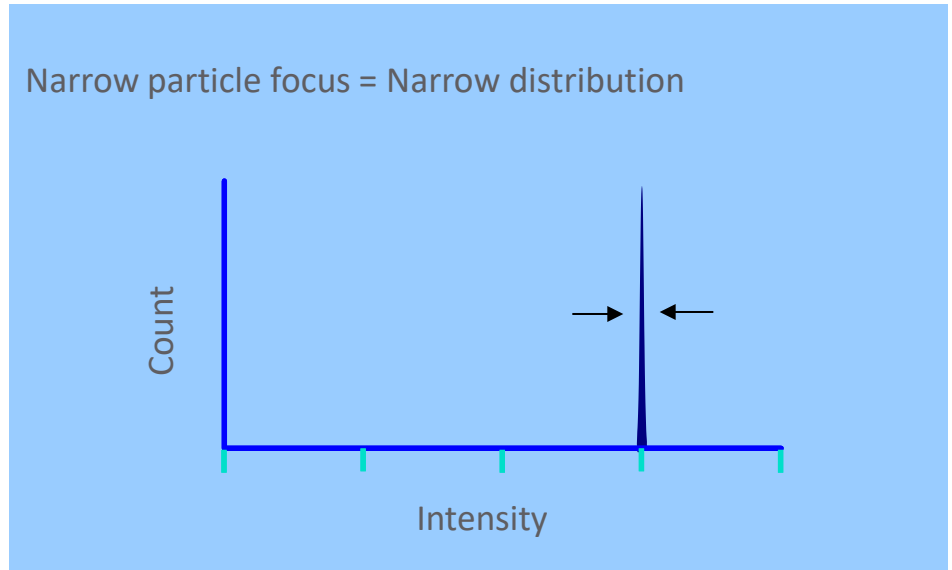
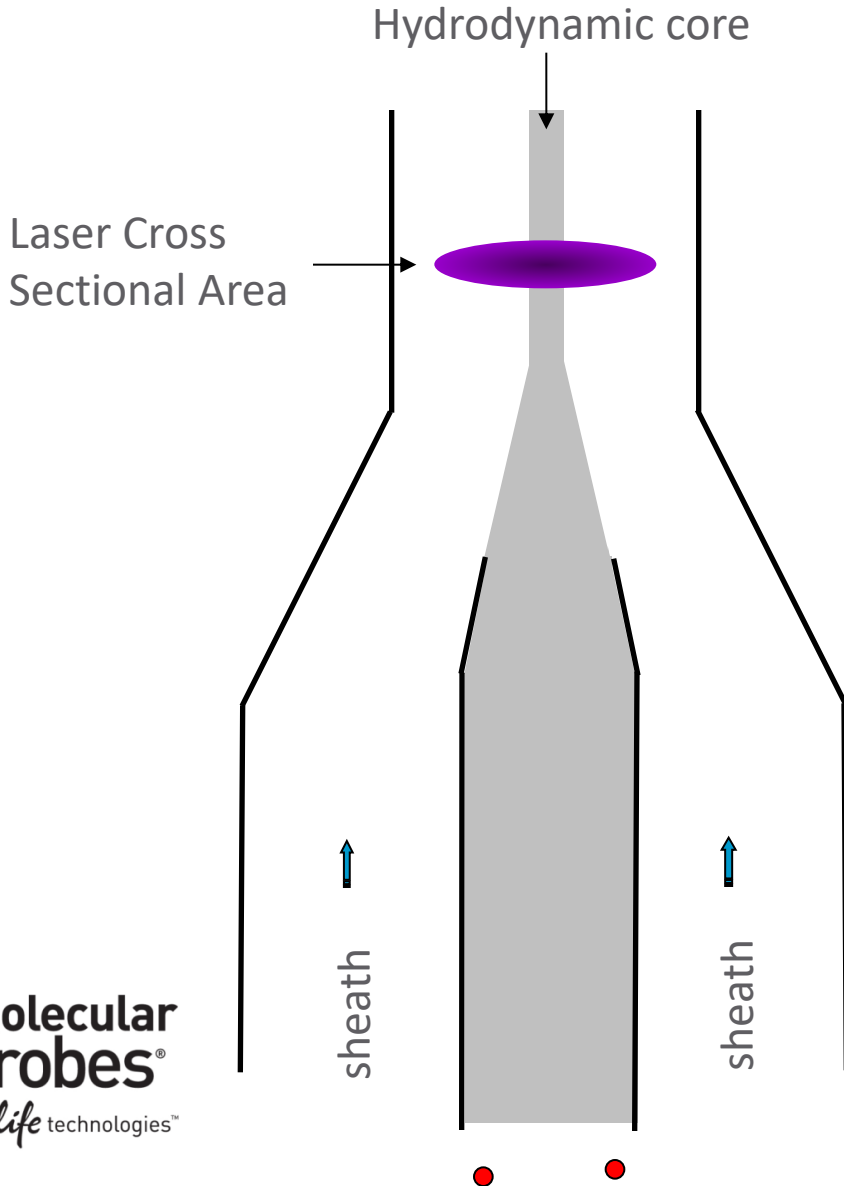

- Sample core is 'pinched' by fast flowing sheath
- Sample volume ratios of 100 – 1000
- Large ratios => low sample inputs
- Resolution of particle populations

# Particle Delivery: Hydrodynamic Focusing

Conventional Instrumentation: **High Flow Rate (60 $\mu$ L/min)**

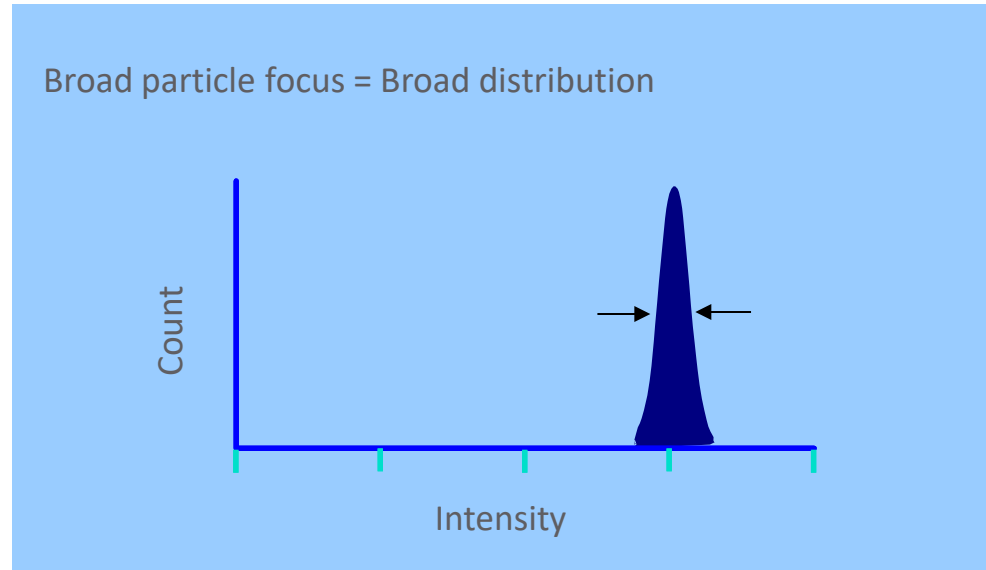
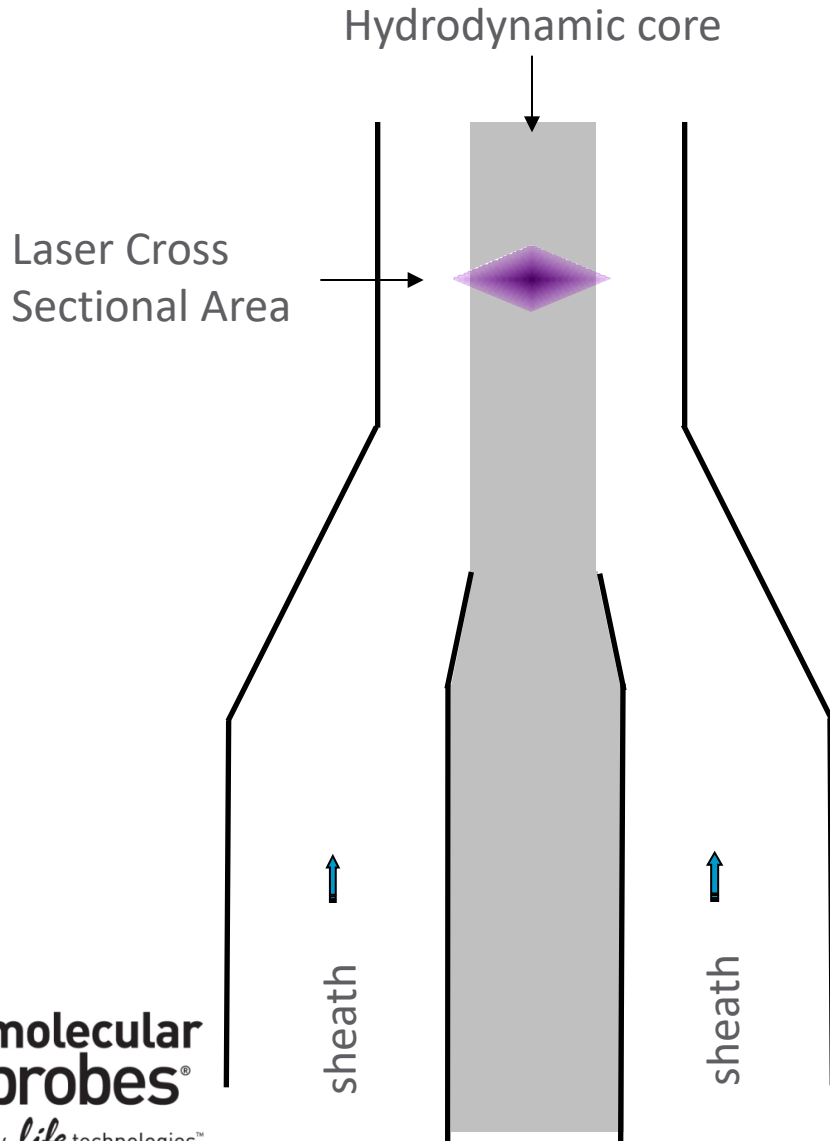

- Increased sample input = increase core size
- Particle distributions broadened, CVs increase
- Instrument resolution decreased
- Historically, low volumetric sample rates used (25  $\mu$ L/min – 150  $\mu$ L/min)

# Attune® Acoustic Focusing Cytometer

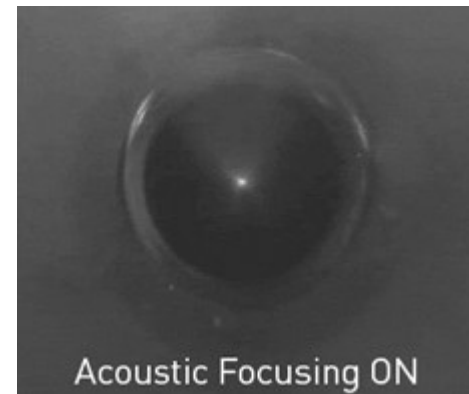
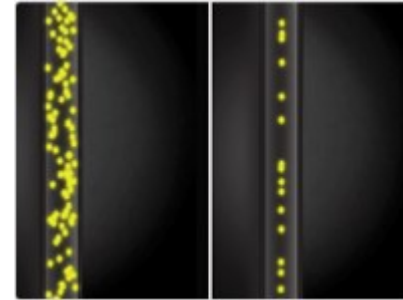
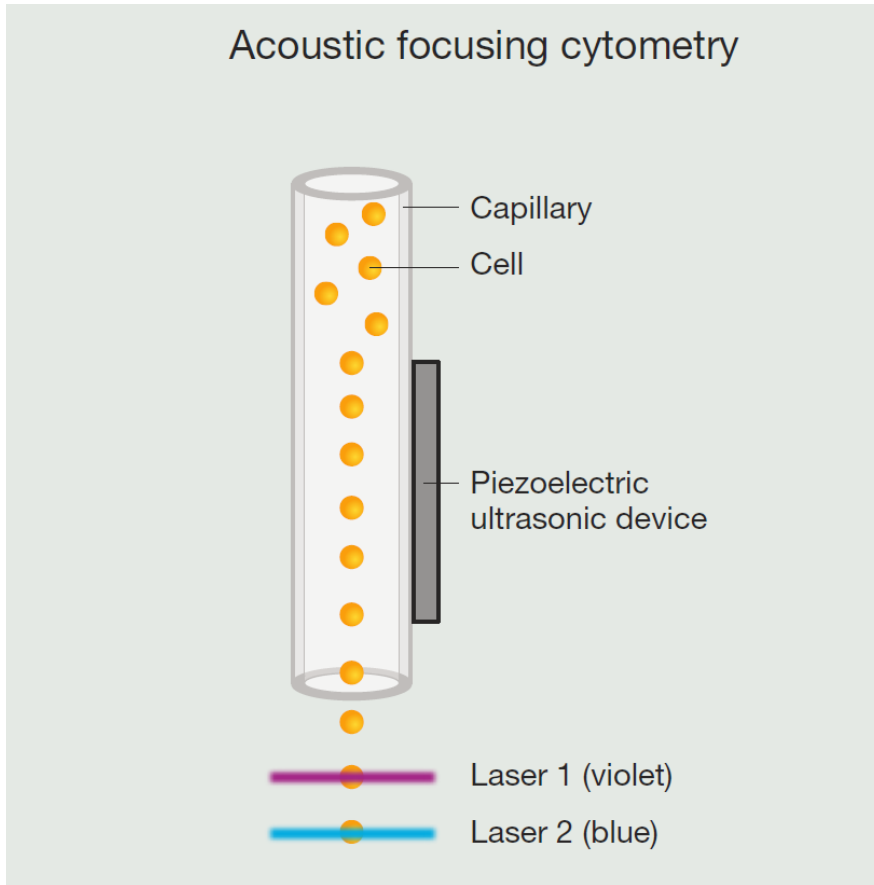



# Acoustic Focusing = Better Precision

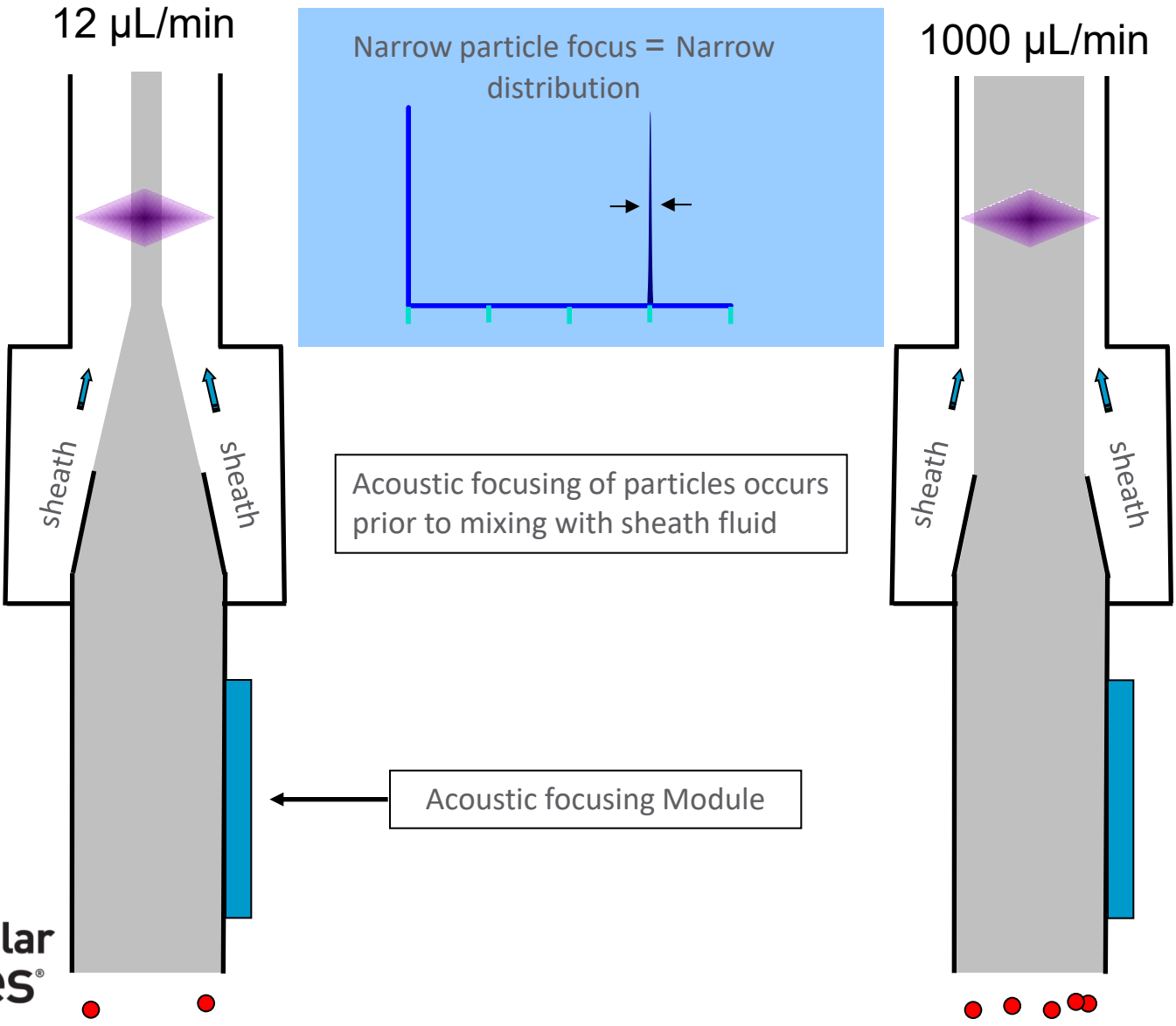

1. Kundt A, Lehmann O (1874) *Annalen der Physik und Chemie (Poggendorff's Annalen)* 153:1–11.
2. Curtis HW, Stephans EJ (1982) *IBM Technical Disclosure Bulletin* 25(1).
3. Yasuda K, Haupt SS, Umemura S (1997) *J Acoust Soc Am* 102:642–645.
4. Jonsson H, Nilsson A, Petersson F et al. (2005) *Perfusion* 20:39–43.
5. Kaduchak G, Goddard G, Salzman G et al. (2008) US Patent 7,340,957.

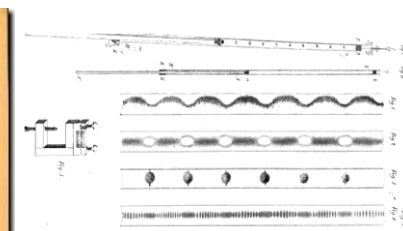

## Using acoustic radiation force as a concentration method for erythrocytes

Kenji Yasuda,<sup>a)</sup> Stephan Shuichi Haupt, and Shin-ichiro Umemura  
*Advanced Research Laboratory, Hitachi, Ltd., 2520 Akanuma, Hatoyama, Saitama 350-03, Japan*

Toshiki Yagi  
*Zoological Institute, Faculty of Science, University of Tokyo, Hongo, Tokyo 113, Japan*

Masaharu Nishida and Yasuhisa Shibata  
*Instrument Division, Hitachi, Ltd., 882 Ichige, Hitachinaka, Ibaraki 312, Japan*

(Received 20 May 1996; accepted for publication 7 March 1997)

We investigated the potential damage inflicted on erythrocytes by acoustic radiation force when the cells are concentrated by a 500-kHz ultrasonic standing wave at the pressure node. The extent of the damage was estimated from the concentrations of potassium ions, iron complexes, and lactate dehydrogenase released from the cells. After 2 min of ultrasound irradiation at  $12.8 \text{ mJ/m}^3$ , the cells concentrated on the pressure node, with a cell distribution half-width of  $138 \mu\text{m}$ ; no significant release of intracellular components was detected, even after 15 min of irradiation. The results indicate that even small ions like potassium are not released as a result of ultrasound irradiation on cell membranes without cavitation, and they demonstrate the potential use of acoustic radiation force for concentrating living cells in biomedical applications. © 1997 Acoustical Society of America. [S0001-4966(97)01407-0]

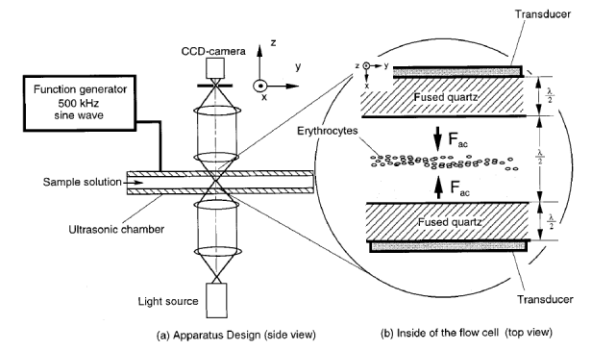
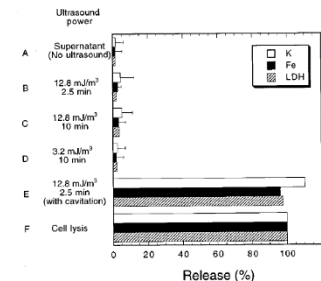
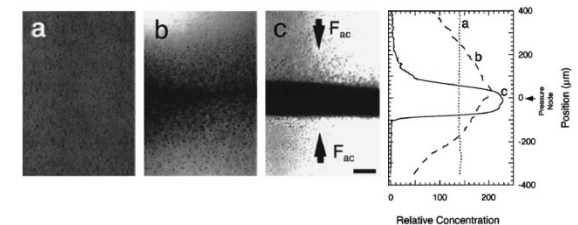

FIG. 1. Schematic diagram of the apparatus for concentration of erythrocytes.







US007340957B2

(12) **United States Patent**  
**Kaduchak et al.**

(10) **Patent No.:** US 7,340,957 B2  
(45) **Date of Patent:** Mar. 11, 2008

(54) **ULTRASONIC ANALYTE CONCENTRATION AND APPLICATION IN FLOW CYTOMETRY**

(75) **Inventors:** Gregory Kaduchak, Los Alamos, NM (US); Greg Goddard, Los Alamos, NM (US); Gary Salzman, White Rock, NM (US); Dipen Sinha, Los Alamos, NM (US); John C. Martin, Los Alamos, NM (US); Christopher Kwiatkowski, Los Alamos, NM (US); Steven Graves, San Juan Pueblo, NM (US)

(73) **Assignee:** Los Alamos National Security, LLC, Los Alamos, NM (US)

(\* ) **Notice:** Subject to any disclaimer, the term of this patent is extended or adjusted under 35 U.S.C. 154(b) by 143 days.

(21) **Appl. No.:** 10/979,065

(22) **Filed:** Nov. 2, 2004

4,523,982 A *	6/1985	Lee	522/21
5,831,166 A *	11/1998	Kozuka et al.	73/570
6,003,388 A *	12/1999	Oeftering	73/864.01
6,216,538 B1 *	4/2001	Yasuda et al.	73/570.5
6,449,563 B1 *	9/2002	Dukhin et al.	702/22
2004/0139792 A1 *	7/2004	Cobb	73/61.75

**FOREIGN PATENT DOCUMENTS**

JP	63139231 A *	6/1988
JP	06241977 A *	9/1994
JP	08266891 A *	10/1996

**OTHER PUBLICATIONS**

King, L. V., "On the acoustic radiation on spheres," *Proc. R. Soc. A.*, 147, 212-240, (1933).

(Continued)

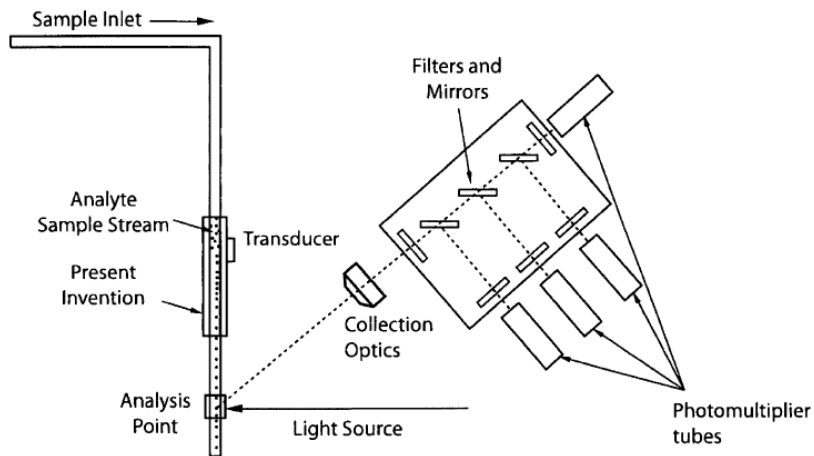
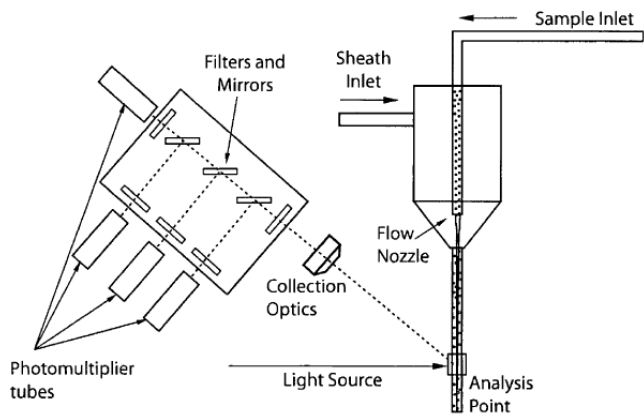
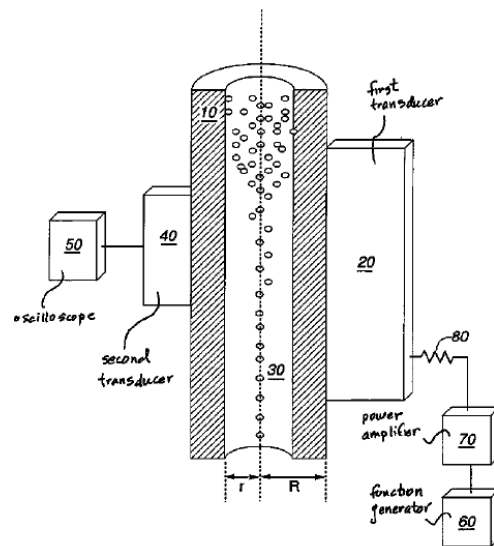

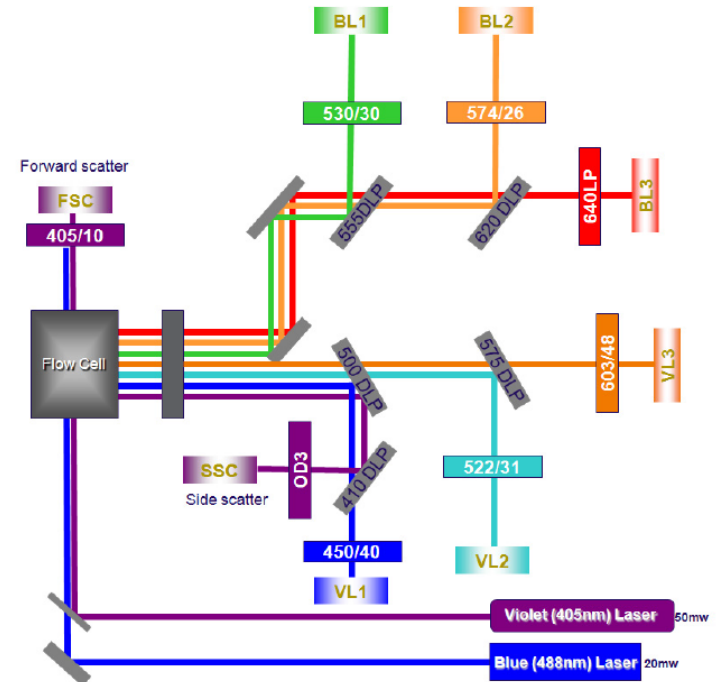
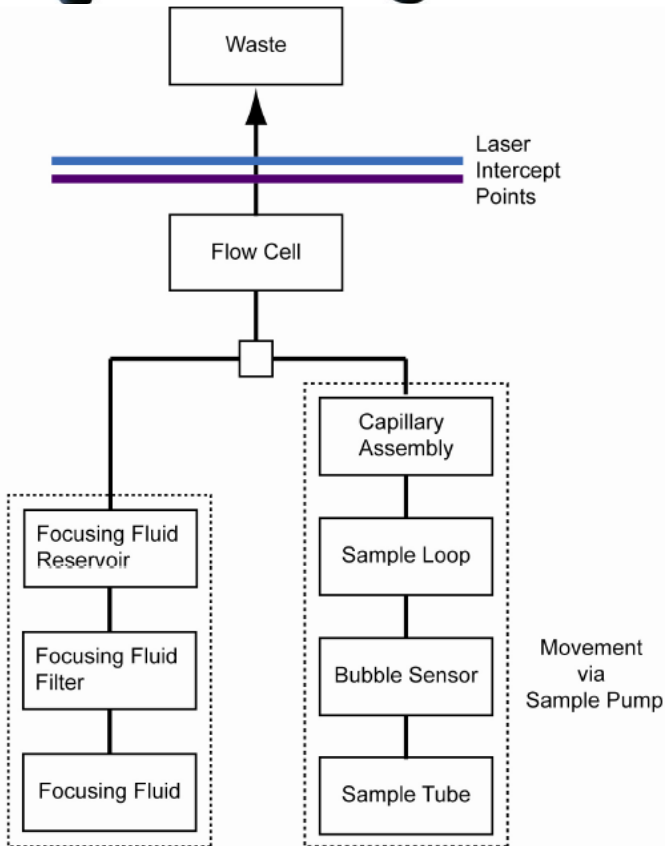

# Attune NxT (2nd generation)

**ThermoFisher**  
SCIENTIFIC



Lasers	Laser configuration (Cat. No.)	Violet 405 nm	Blue 488 nm	Yellow 561 nm	Green 532 nm	Red 637 nm	Total detection channels*
1	Blue (A24864)	Available as upgrade	4	Available as upgrade	Available as upgrade	Available as upgrade	6
2	Blue/green (A28995)	Available as upgrade	3	–	4	Available as upgrade	9
	Blue/yellow (A24861)	Available as upgrade	3	4	–	Available as upgrade	9
	Blue/violet (A24862)	4	4	Available as upgrade	Available as upgrade	Available as upgrade	10
	Blue/red (A24863)	Available as upgrade	4	Available as upgrade	Available as upgrade	3	9
3	Blue/green/red (A28997)	Available as upgrade	3	–	4	3	12
	Blue/green/violet (A28999)	4	3	–	4	Available as upgrade	13
	Blue/red/yellow (A28993)	Available as upgrade	3	4	–	3	12
	Blue/violet/yellow (A24859)	4	3	4	–	Available as upgrade	13
	Blue/red/violet (A24860)	4	4	Available as upgrade	Available as upgrade	3	13
4	Blue/red/violet/green (A29001)	4	3	–	4	3	16
	Blue/red/yellow/violet (A24858)	4	3	4	–	3	16

\* Includes forward scatter (FSC) and side scatter (SSC).

# Attune® Throughput Compared to Hydrodynamic Focused Instruments

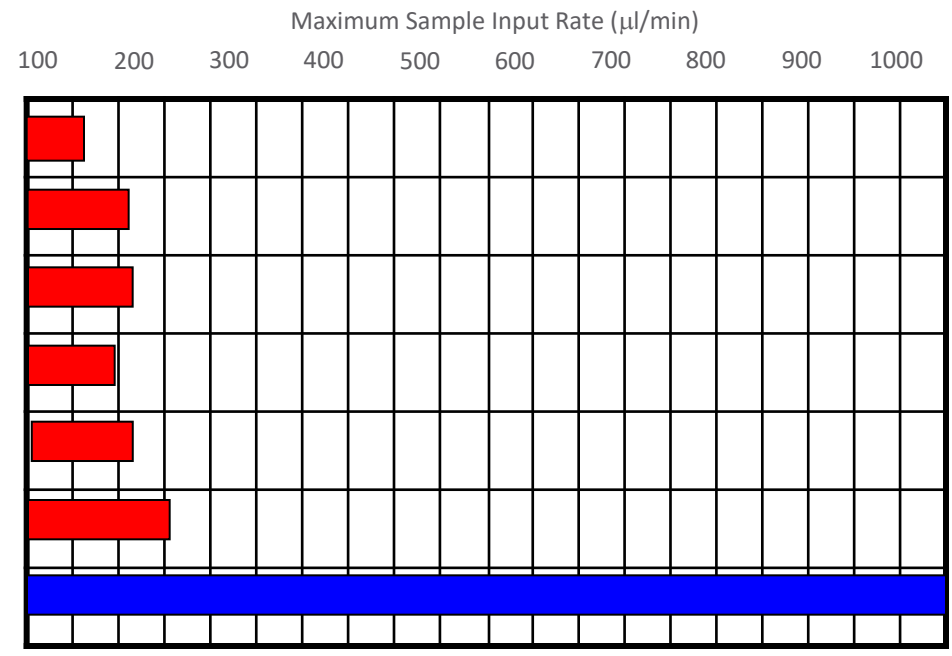

Hydrodynamic Focused Instruments

- Attune® can analyze at sample rates from 25µL/min to 1000µL/min without losing accuracy
- Traditional Flow Cytometers can only run at most 150µL/min and will sacrifice data quality
- Higher sample rates enable dilution of limited samples and analysis of Rare Events Faster

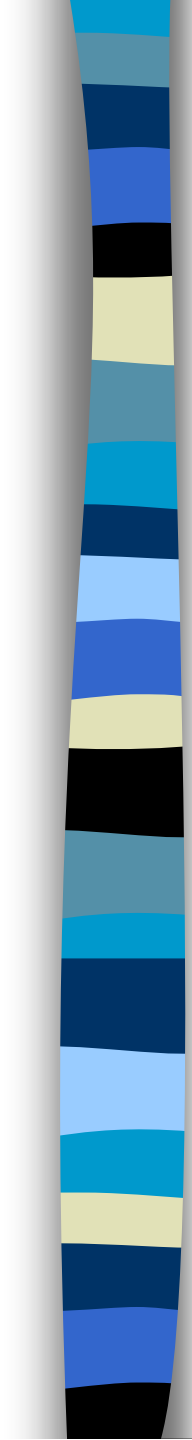

# Fluidika - shrnutí

- Průtok musí být laminární (Reynoldovo #)
  - $R_e < 2300$ , flow je vždy **laminární**
- Vzorky mohou být injikovány a nebo proudit na základě rozdílných tlaků
- Existuje mnoho typů průtokových komor
- Pro přesnost měření je nutné odstranit a zabránit ucpání komory



## Fluidika – shrnutí 2

- tlak nosné (oplašťující) kapaliny vede pufr kyvetou a vyšší tlak ve zkumavce se vzorkem zavádí vzorek do kyvety.
- Princip hydrodynamického zaostření zarovná buňky v kyvetě „jako perly na šňůrce“ předtím než dojdou do bodu kde protnout paprsek laseru.
- Hydrodynamické zaostření nemůže oddělit buněčné agregáty. Průtoková cytometrie vyžaduje suspenzi jednotlivých buněk!



# Principy průtokové cytometrie a sortování

- sorting





Doležel (1999)





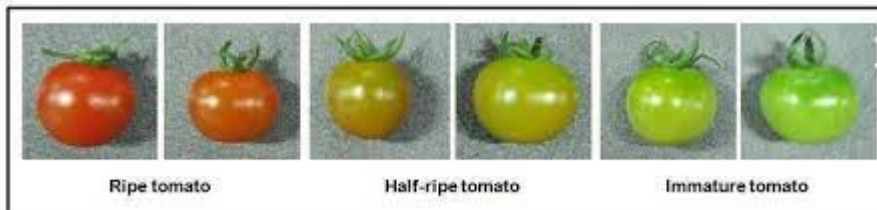
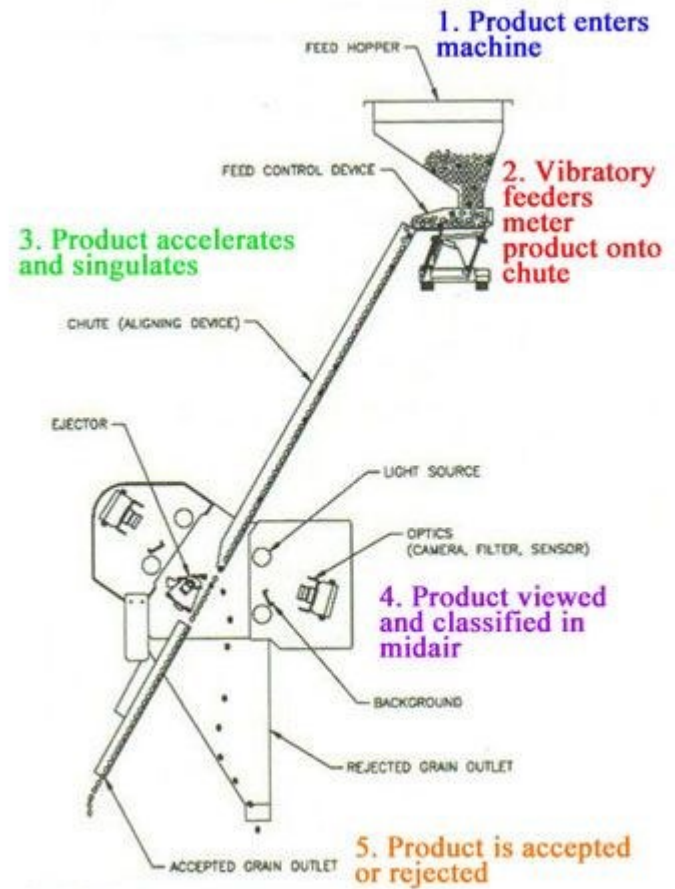
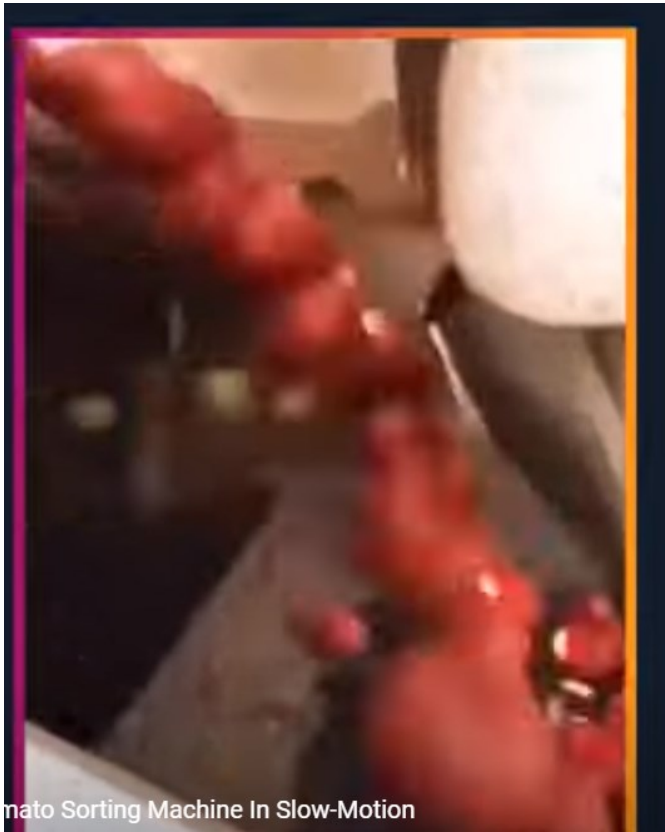

# ELECTROSTATIC DROPLET SORTER

- High speed ( $\sim 10^4/\text{sec}$ )
  - Concentrated sorted fraction
  - Biosafety hazard
  - Mechanical shearing
- Problems to sort large particles

Used by:  
Becton Dickinson  
Beckman Coulter  
Cytomation

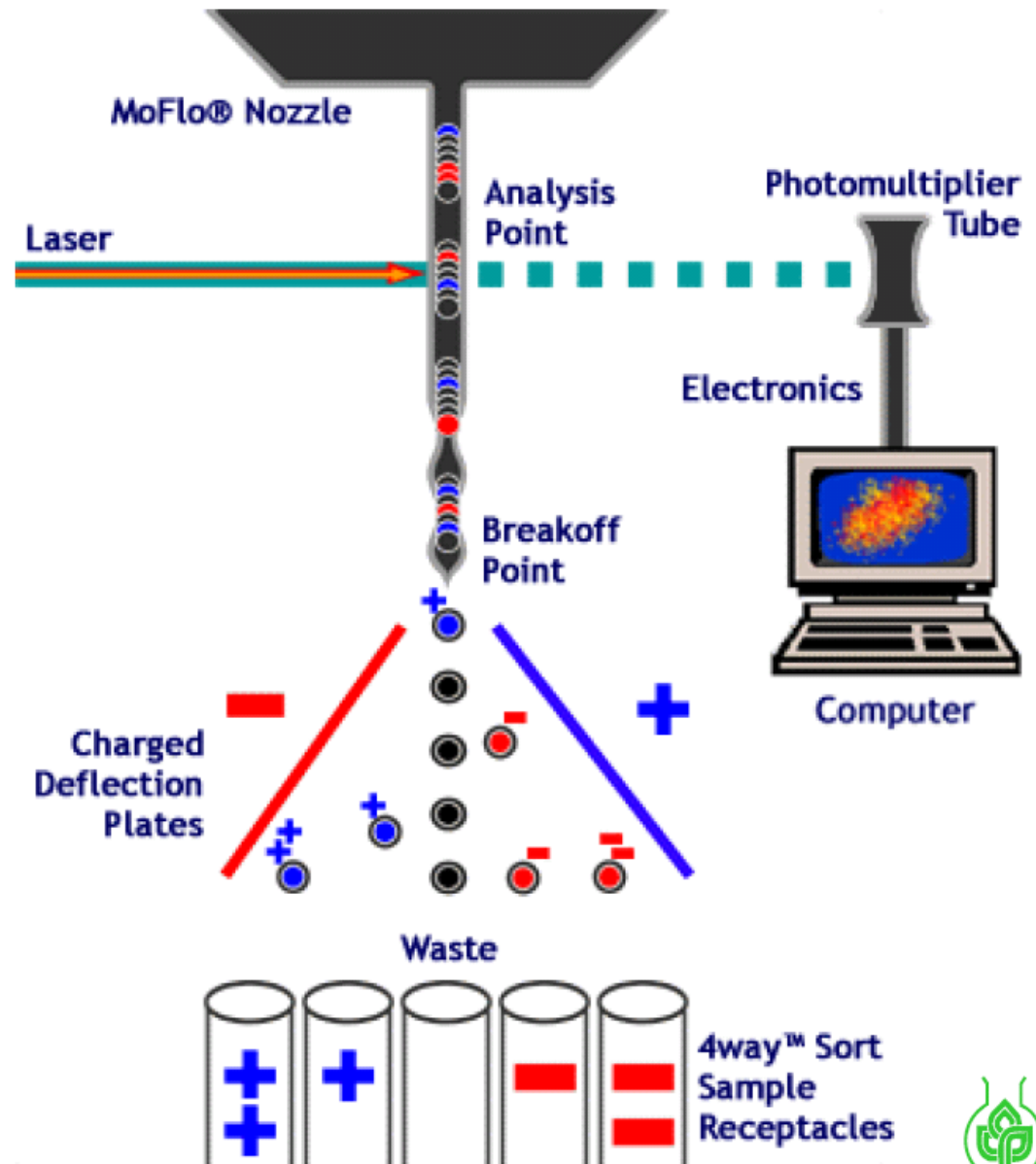

Doležel (1999)



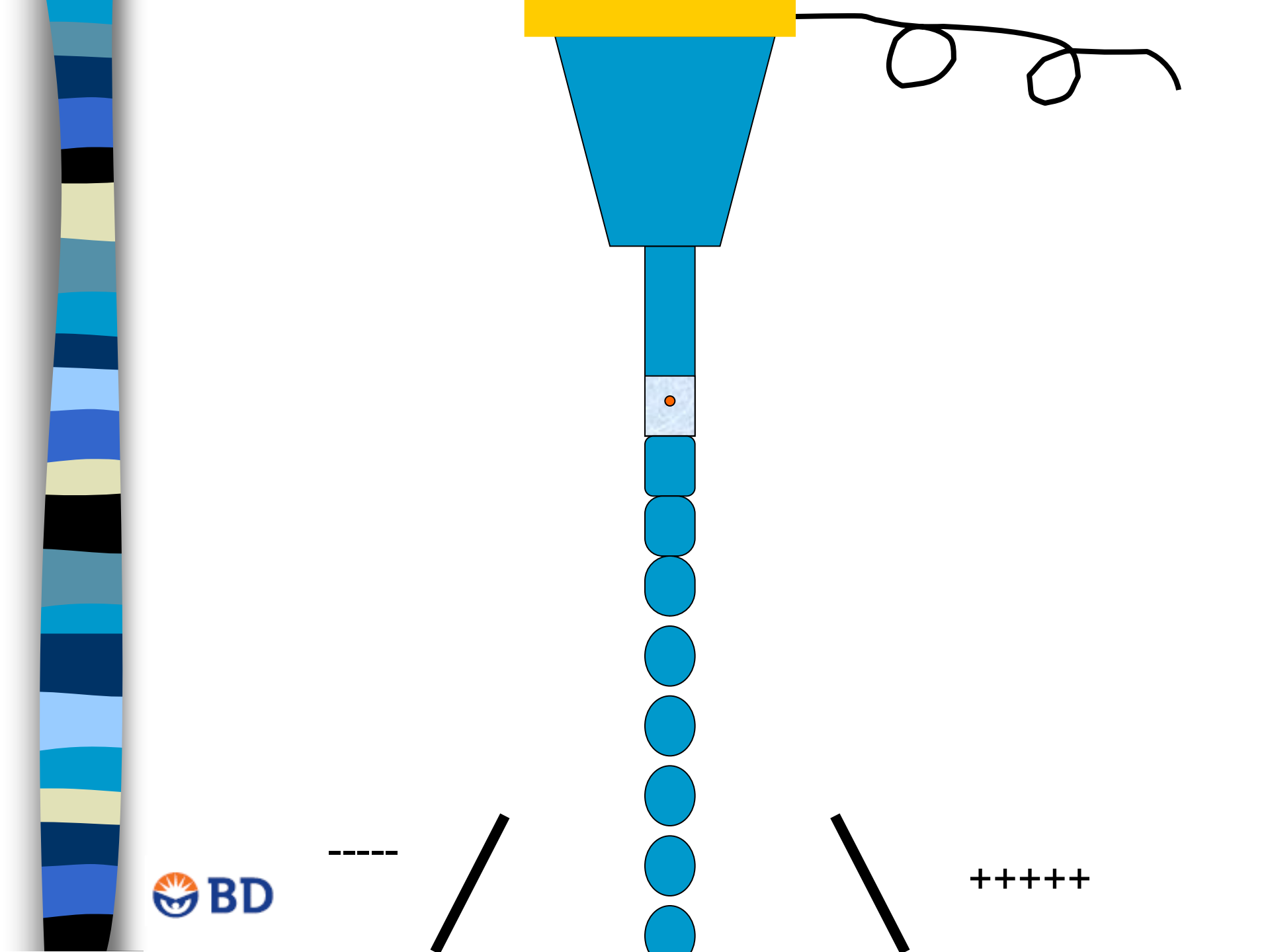

-----

+++++

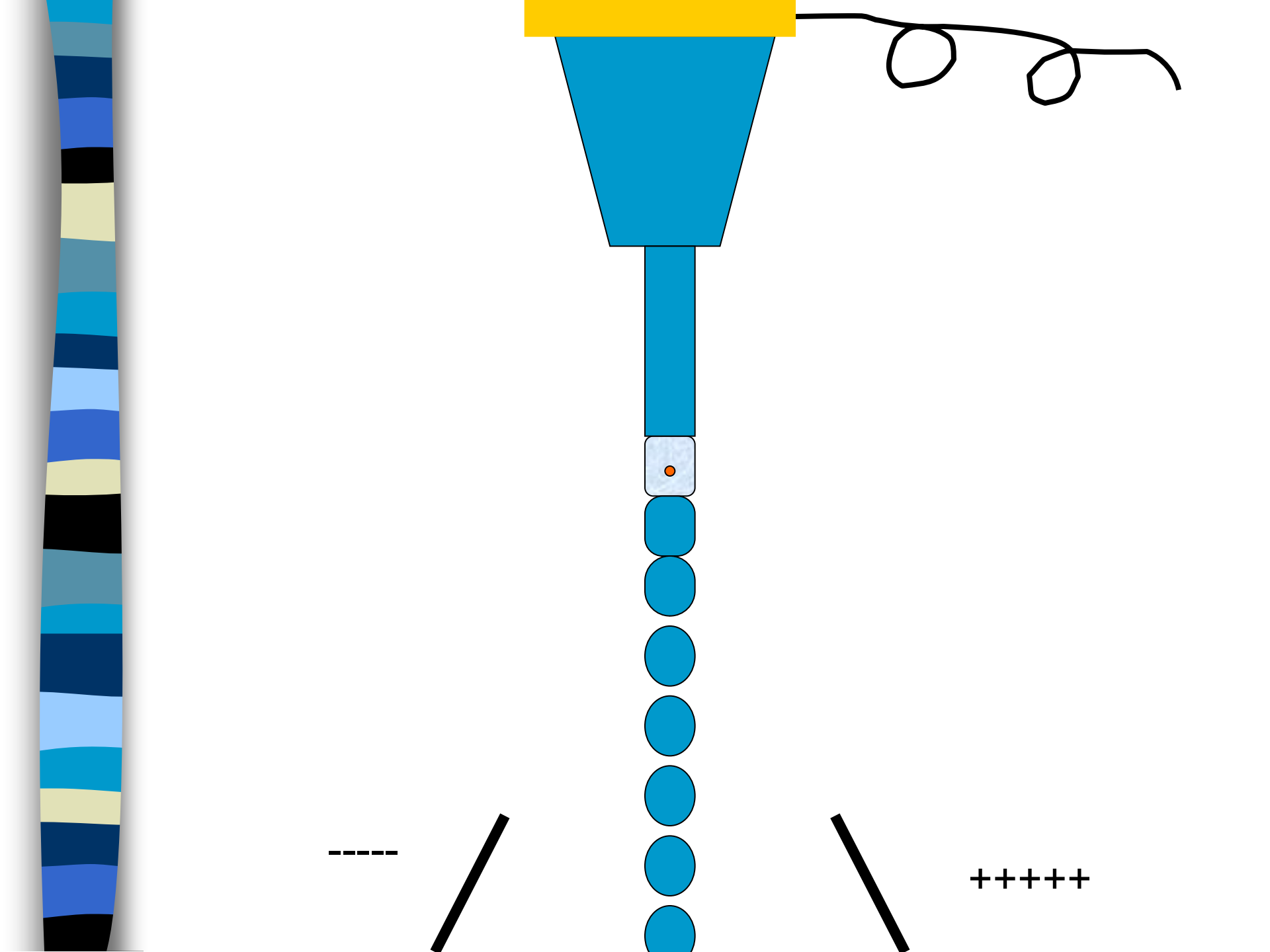

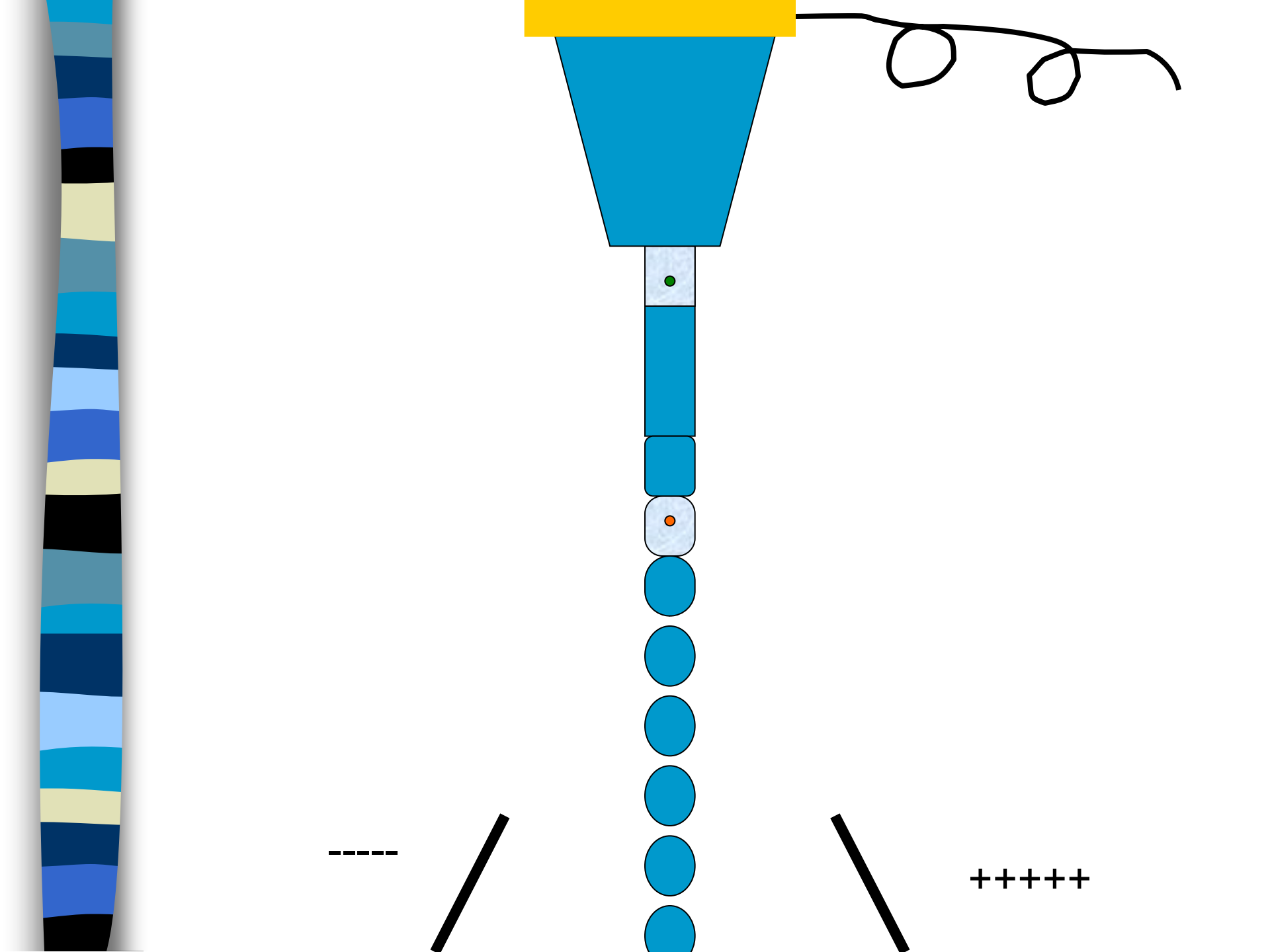

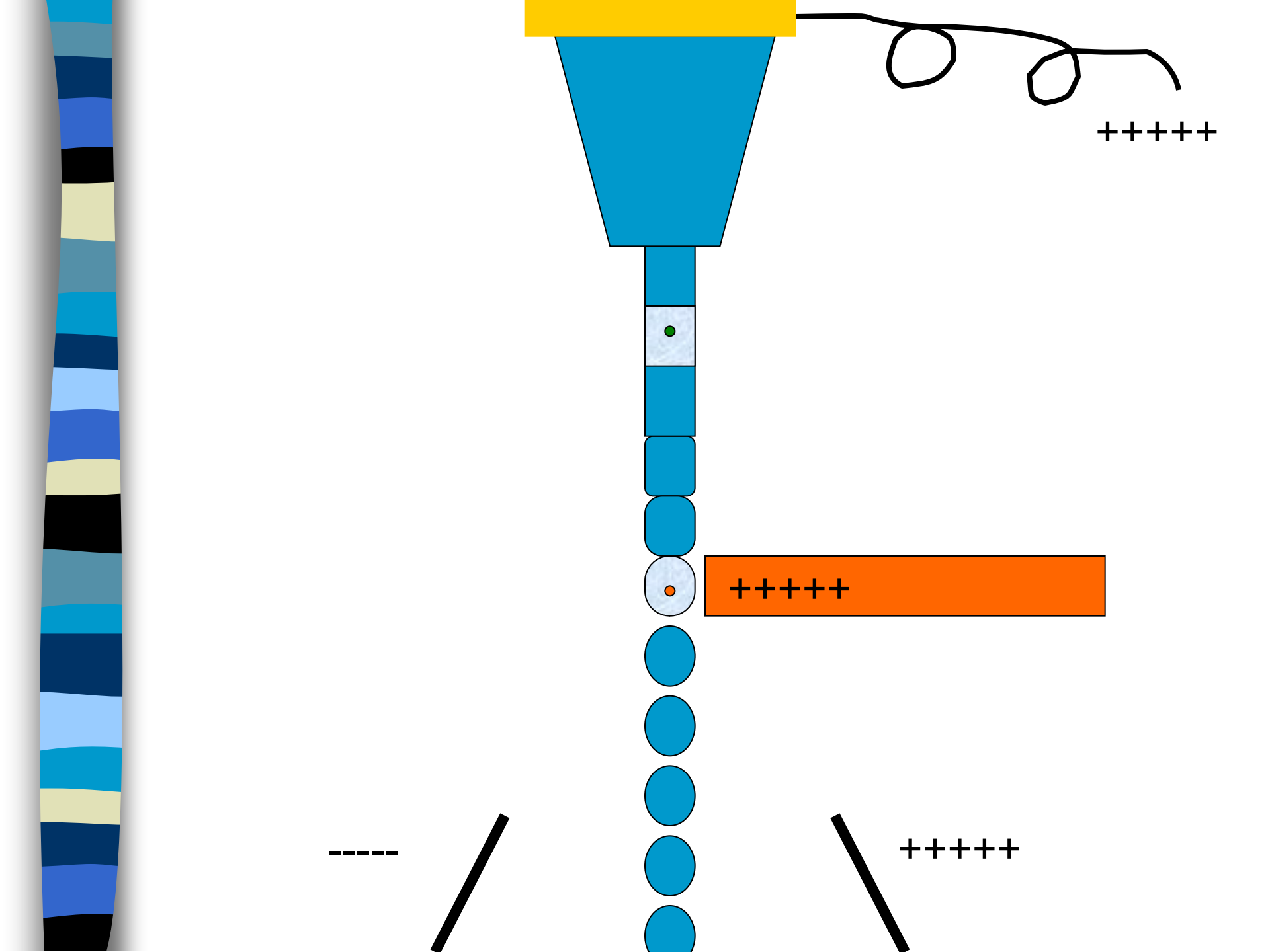

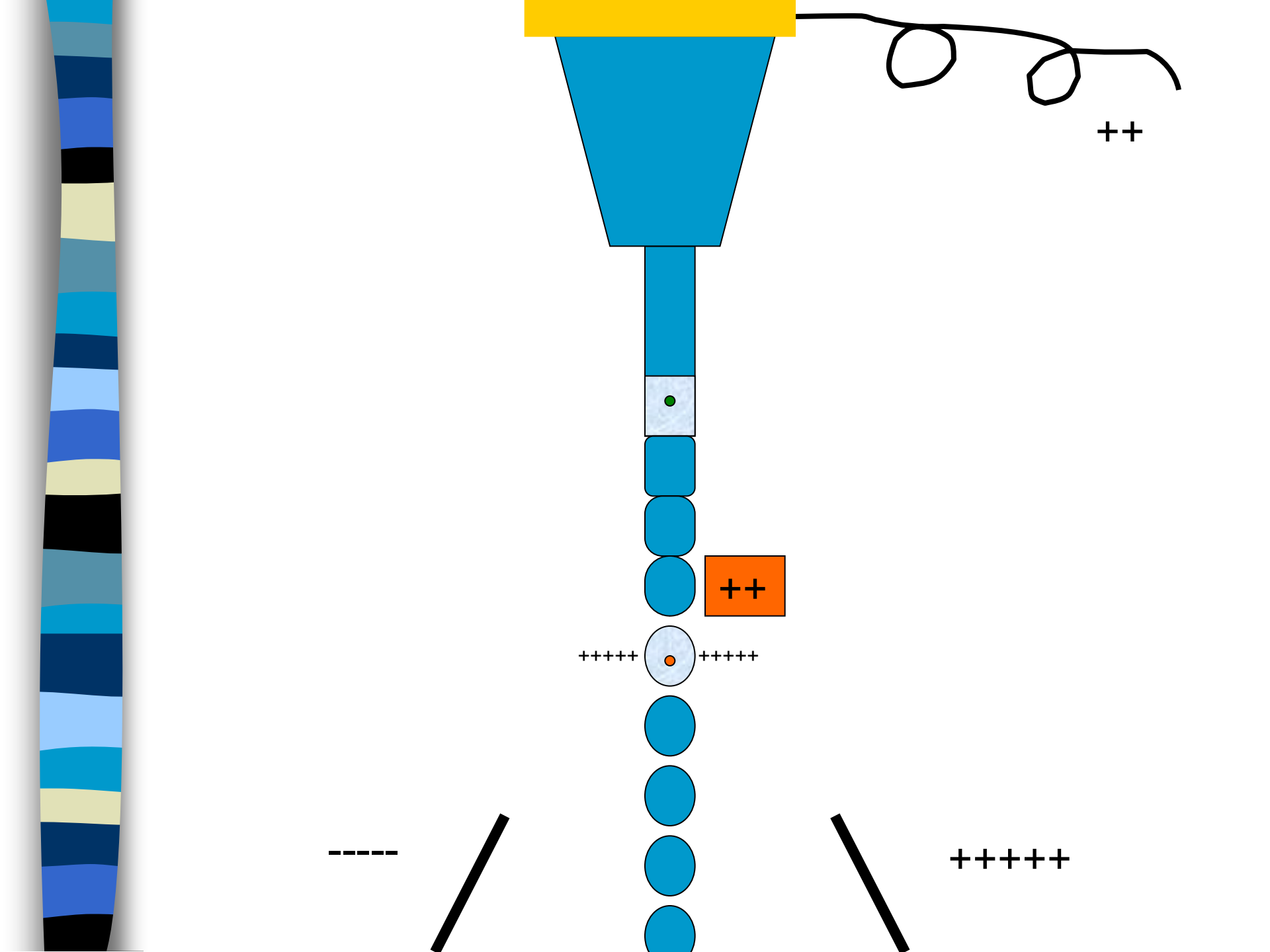

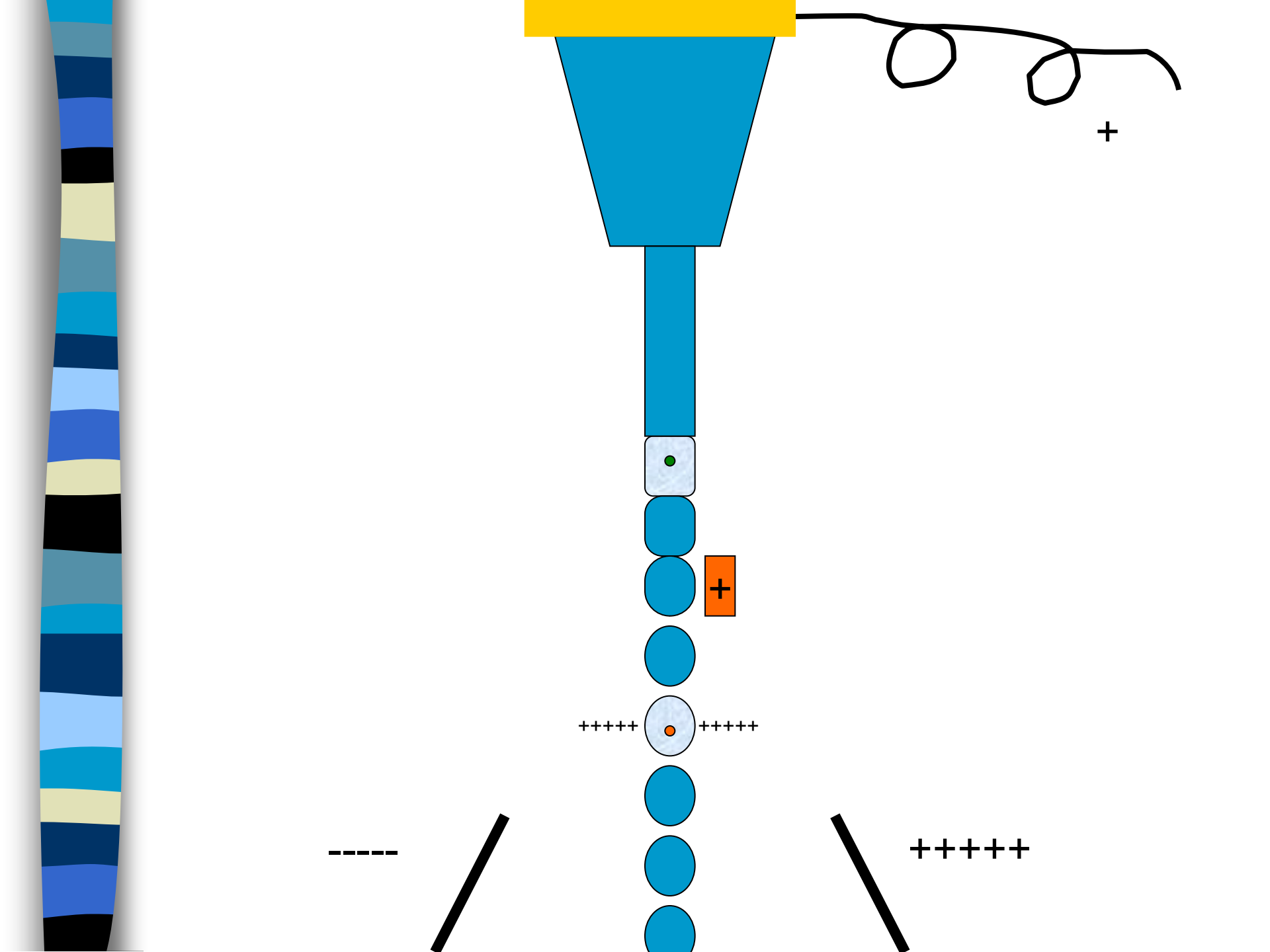



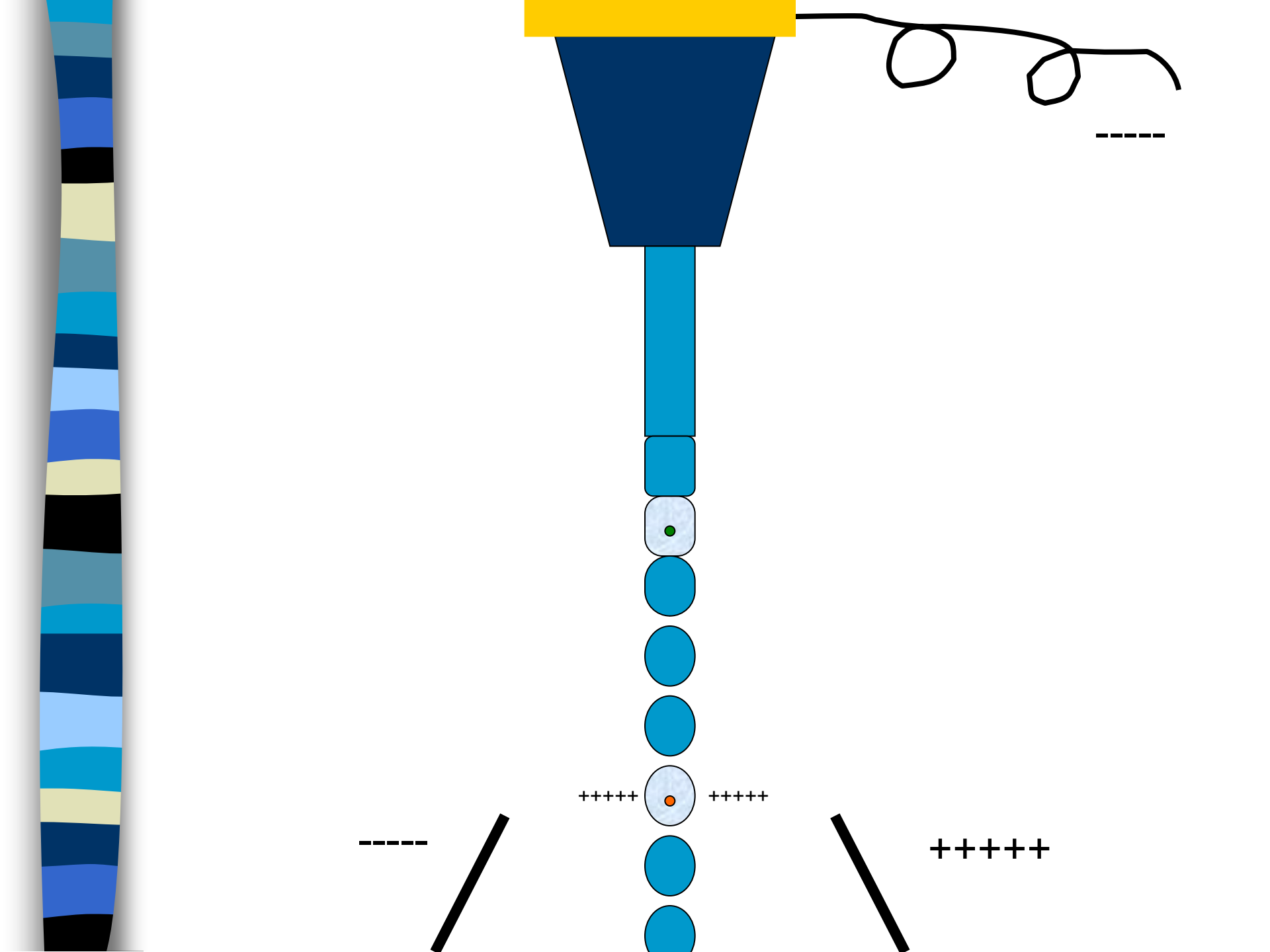



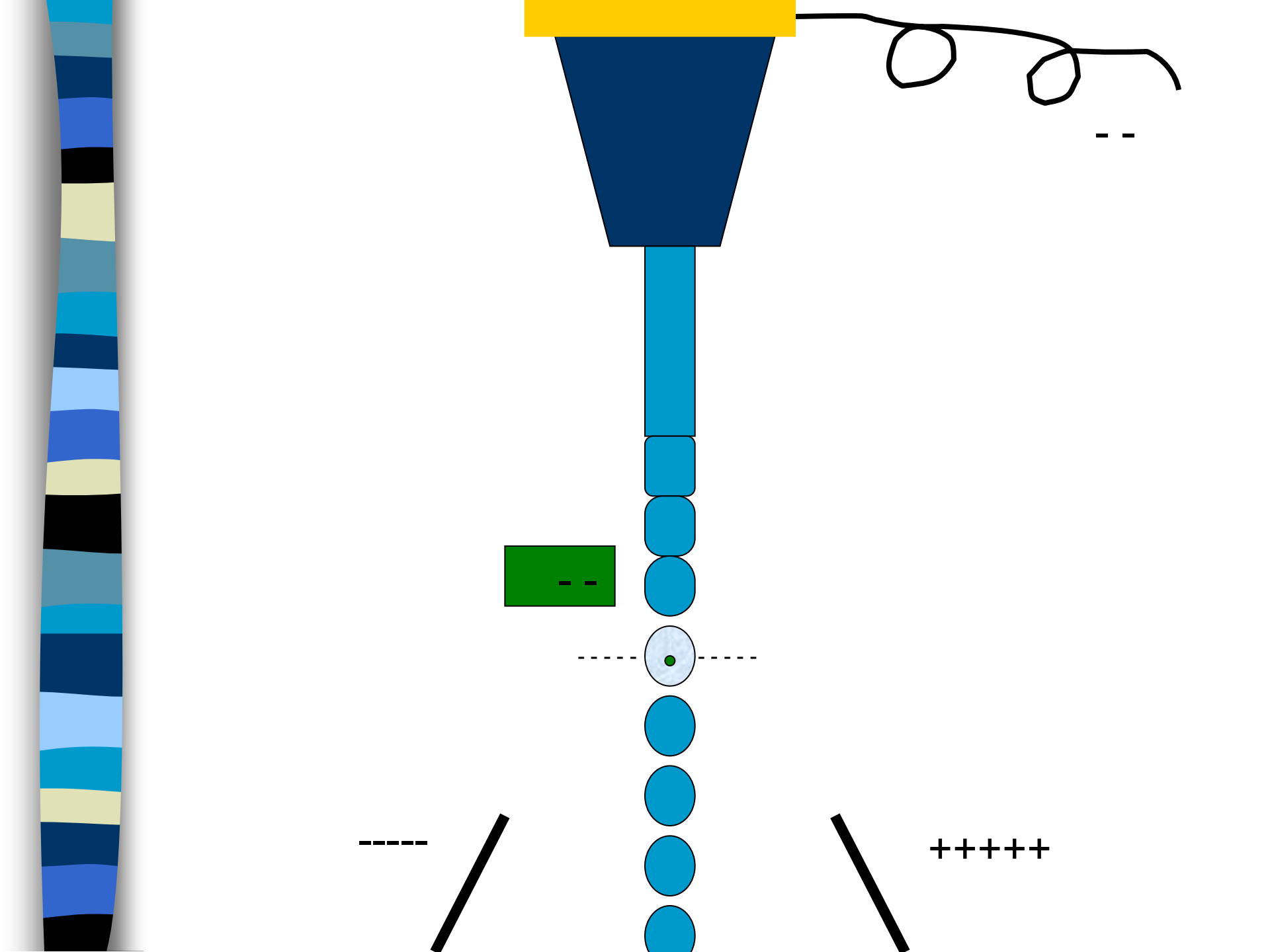

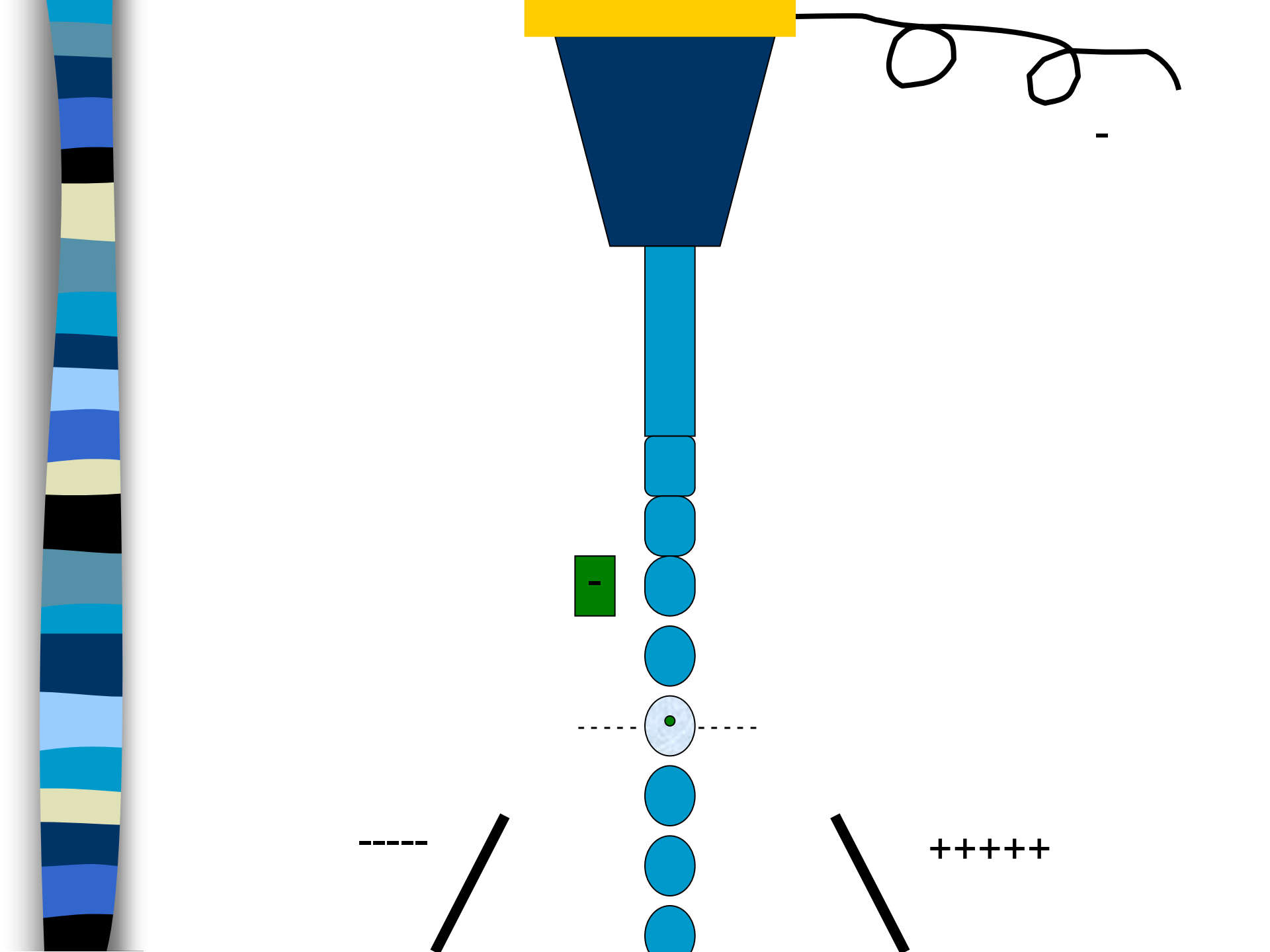

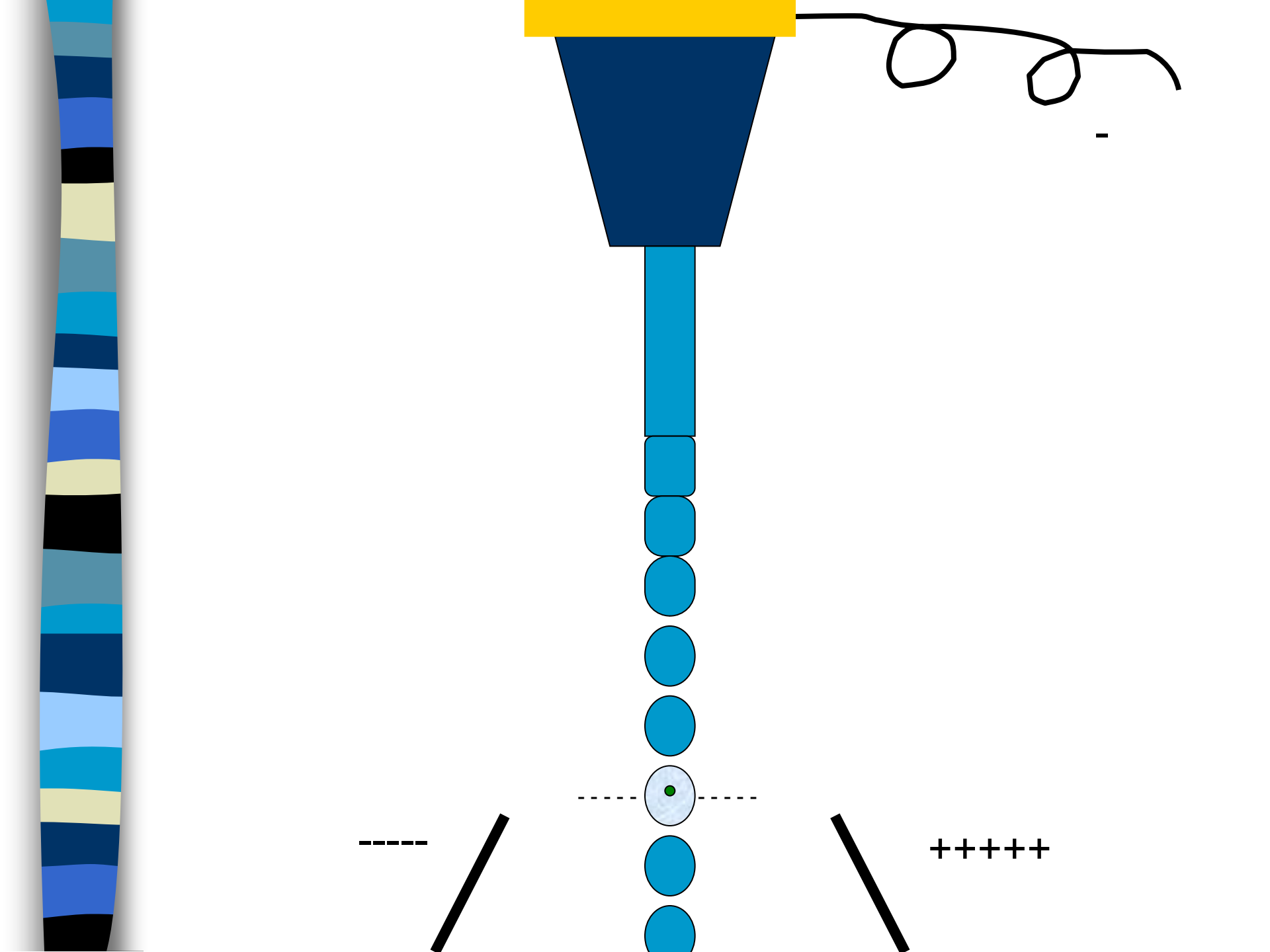

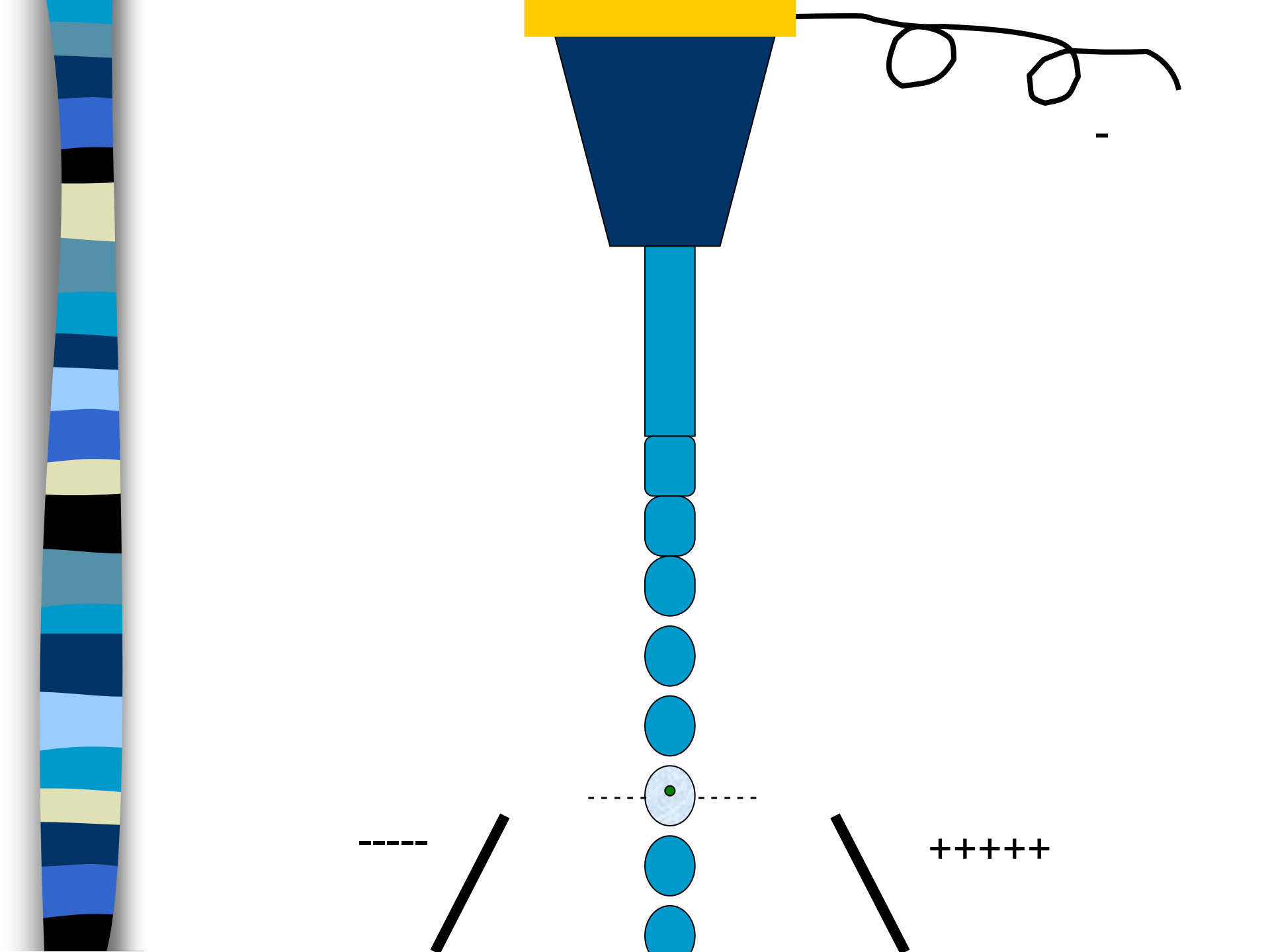

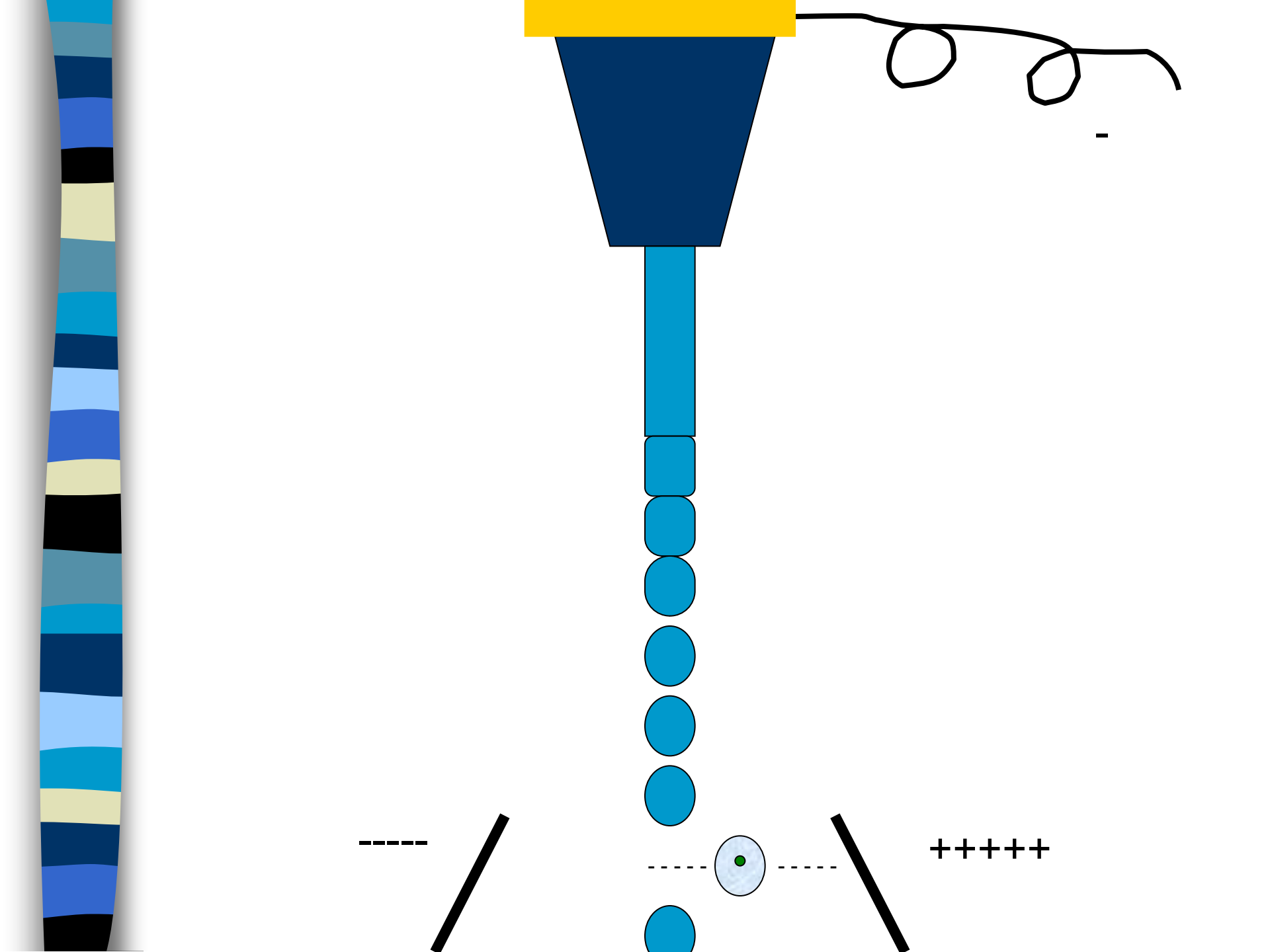



# ISAC presents: Mack Fulwyler - Innovator, Inventor & Pioneer

<http://www.cyto.purdue.edu/cdroms/cyto10a/seminalcontributions/fulwyler.html>



# FLUIDIC SWITCH SORTER

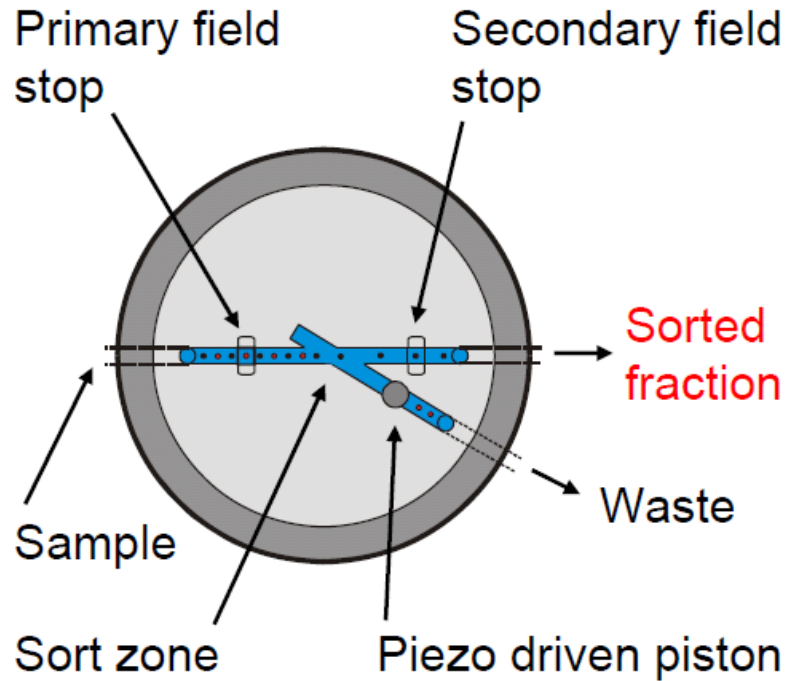

- Safety (enclosed stream)
- Gentle to cells
- Sorting of large particles ( $>100\ \mu\text{m}$ )

Low speed ( $\sim 100/\text{sec}$ )

- Dilute sorted fraction
- Noisy

Used by: Partec

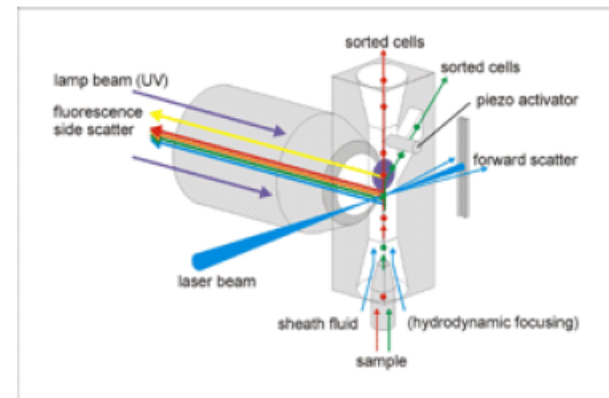
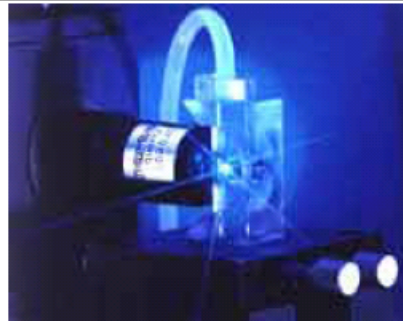

# FLUIDIC SWITCH SORTER

- Safety (enclosed stream)
- Gentle to cells
- Low speed ( $\sim 100$  / sec)
- Dilute sorted fraction
- Noisy

Used by: Becton Dickinson

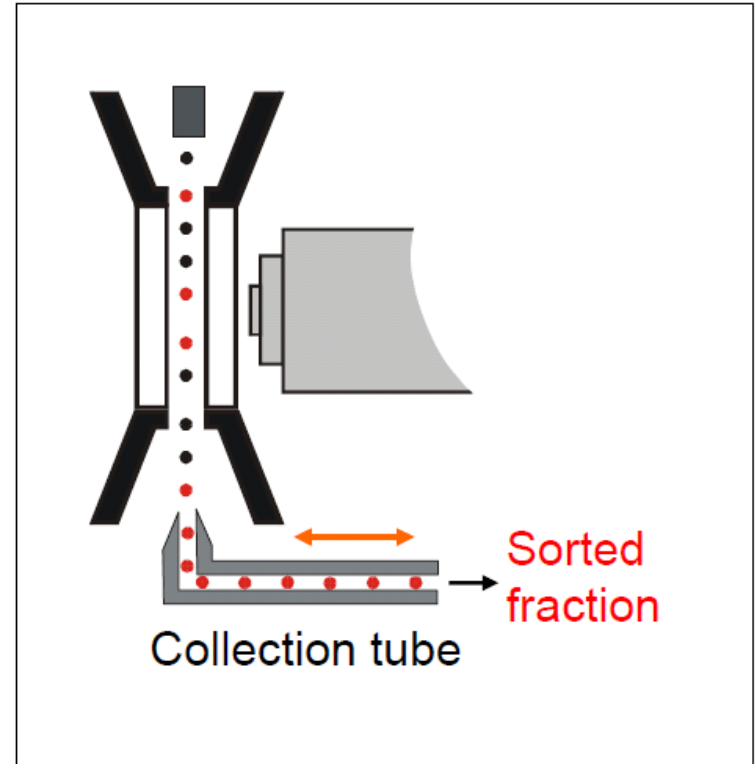



# **SORTING**

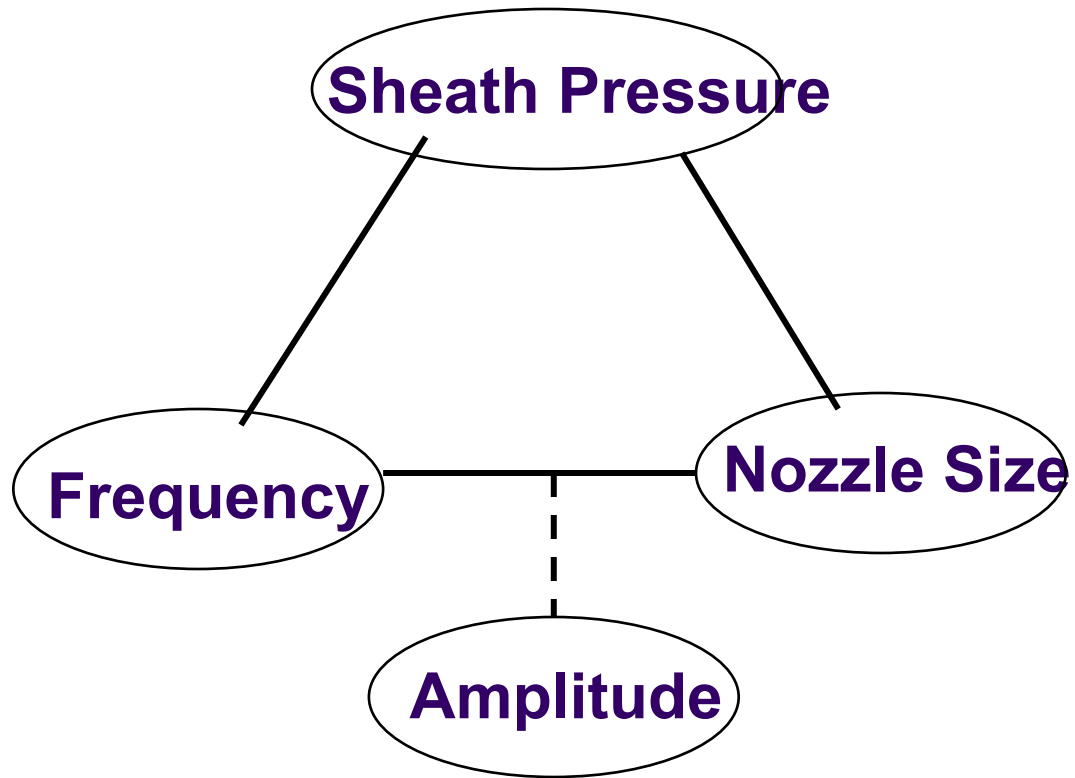

# SORTING

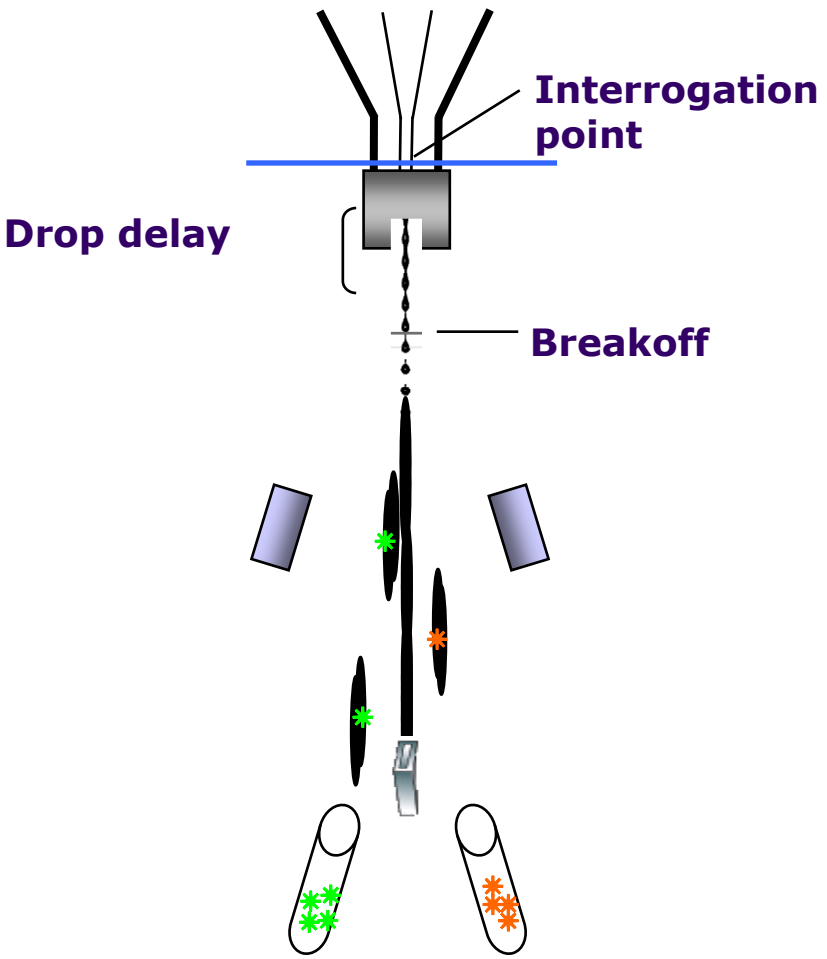

# **SORTING**

**Each sort setup includes:**

**Sheath pressure**

**Breakoff window values**

**Side Stream window values**

**Table 3-2** Default Sort Setup values

<b>Setting</b>	<b>70 micron</b>	<b>85 micron</b>	<b>100 micron</b>	<b>130 micron</b>
Sheath Pressure	70	45	20	10
Amplitude	60	32	12	24
Frequency	87	47	30	12
Drop 1	150	150	150	150
Gap (upper limit)	6 (14)	7 (17)	10 (21)	12 (21)
Attenuation	Off	Off	Off	Off
Drop Delay	47.00	30.00	27.00	16.00
Far left voltage	100	100	80	60





# SORTING - Streams

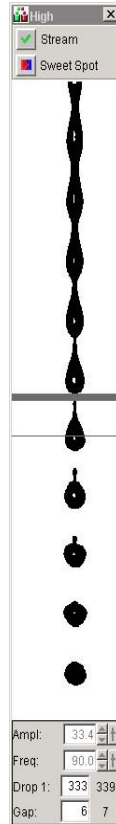

Good

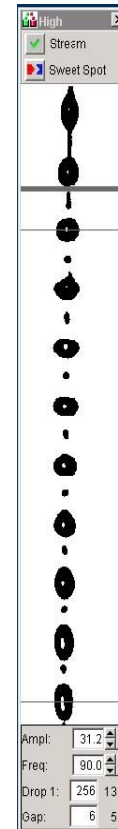

Bad

# SORTING – Setup Side Streams

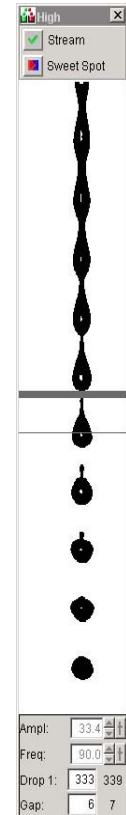
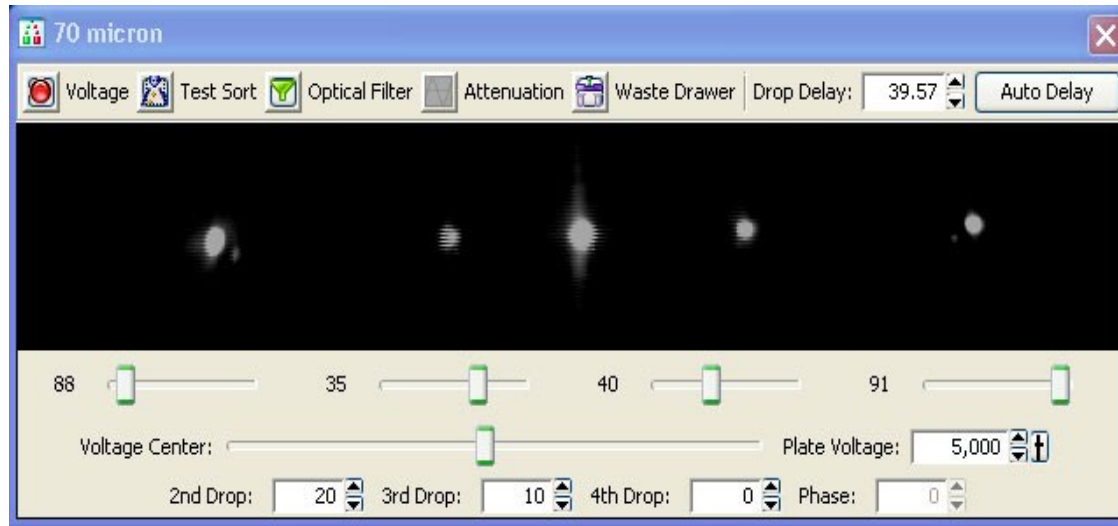

# Drop Delay

BD FACS™

Accudrop  
technology

- Accudrop beads
- Diode laser
- Camera
- Optical filter

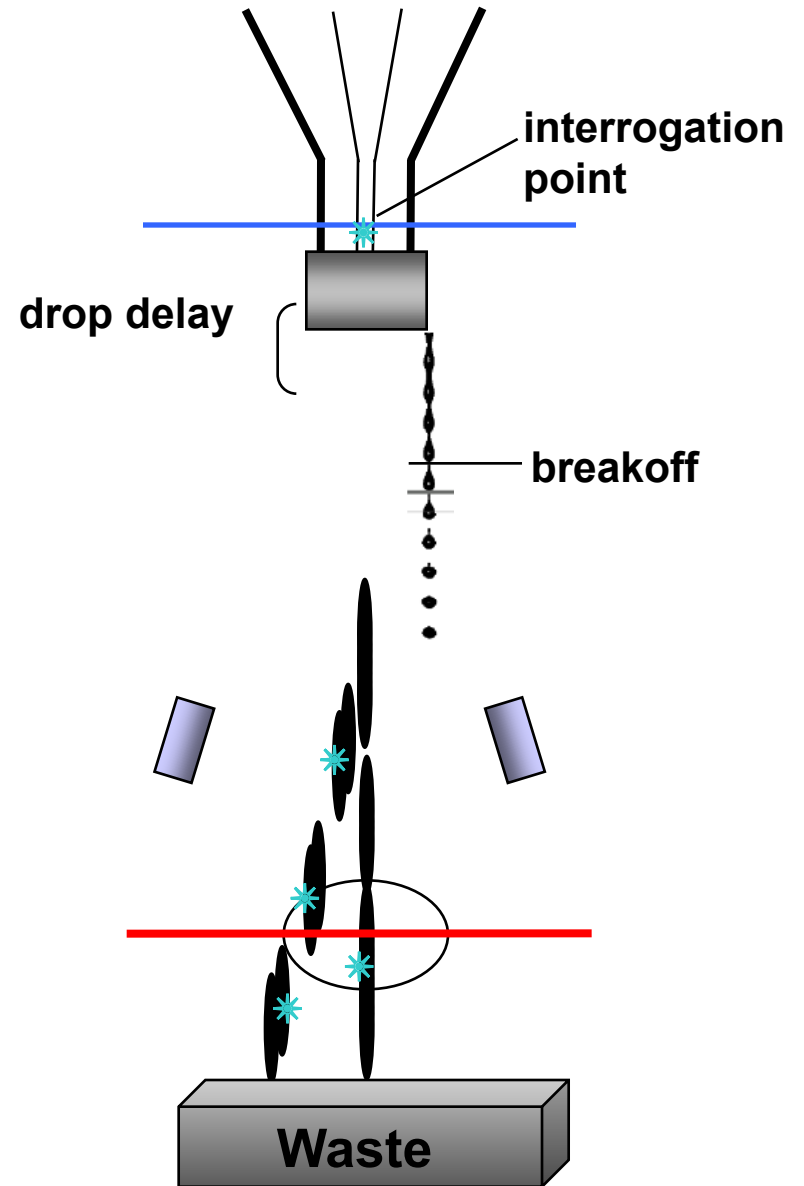

# Sorting - Sort Masks

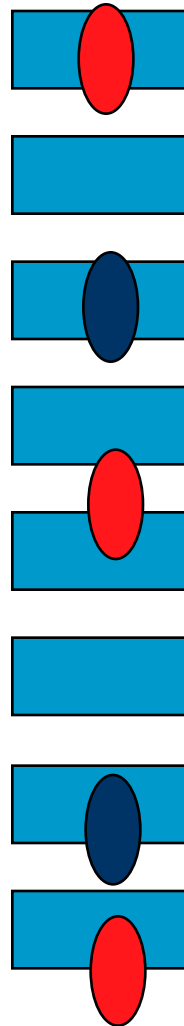

Cells are randomized  
distributed over the stream

# Conflict Resolution

- Precision modes include three types of masks
  - Yield
  - Purity
  - Phase

	Precision Mode				
	Purity	Yield	Single Cell	Initial	Fine Tune
Yield Mask:	32	32	0	32	0
Purity Mask:	32	0	32	0	0
Phase Mask:	0	0	16	0	0
Single Cell:	<input type="checkbox"/>	<input type="checkbox"/>	<input checked="" type="checkbox"/>	<input type="checkbox"/>	<input type="checkbox"/>

# Sorting - Sort Masks

Sort decisions are determined by sort masks

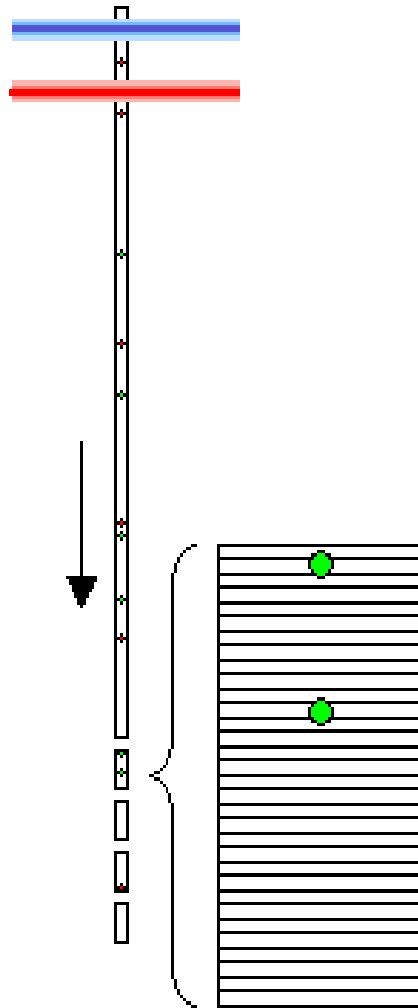

Target particles in a drop with  
1/32-drop resolution

# Sorting - Yield Mask

The yield mask defines how many drops will be sorted. Yield mask of 8/32 indicated in blue; target particle shown in green

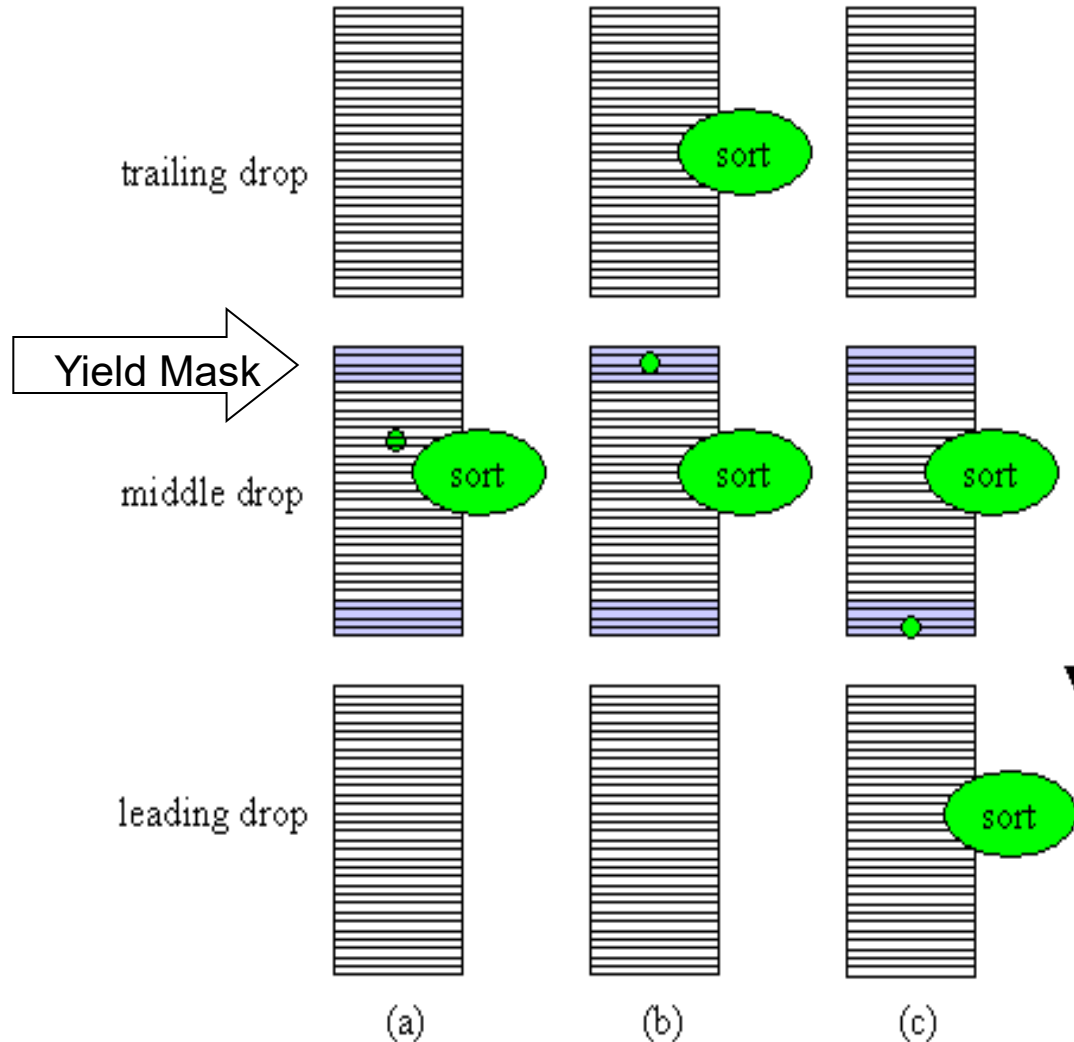



# Sorting - Purity Mask

Purity mask of 8/32 in blue, 4/32 in each adjacent drop;  
target particles in green, non-target particles in red

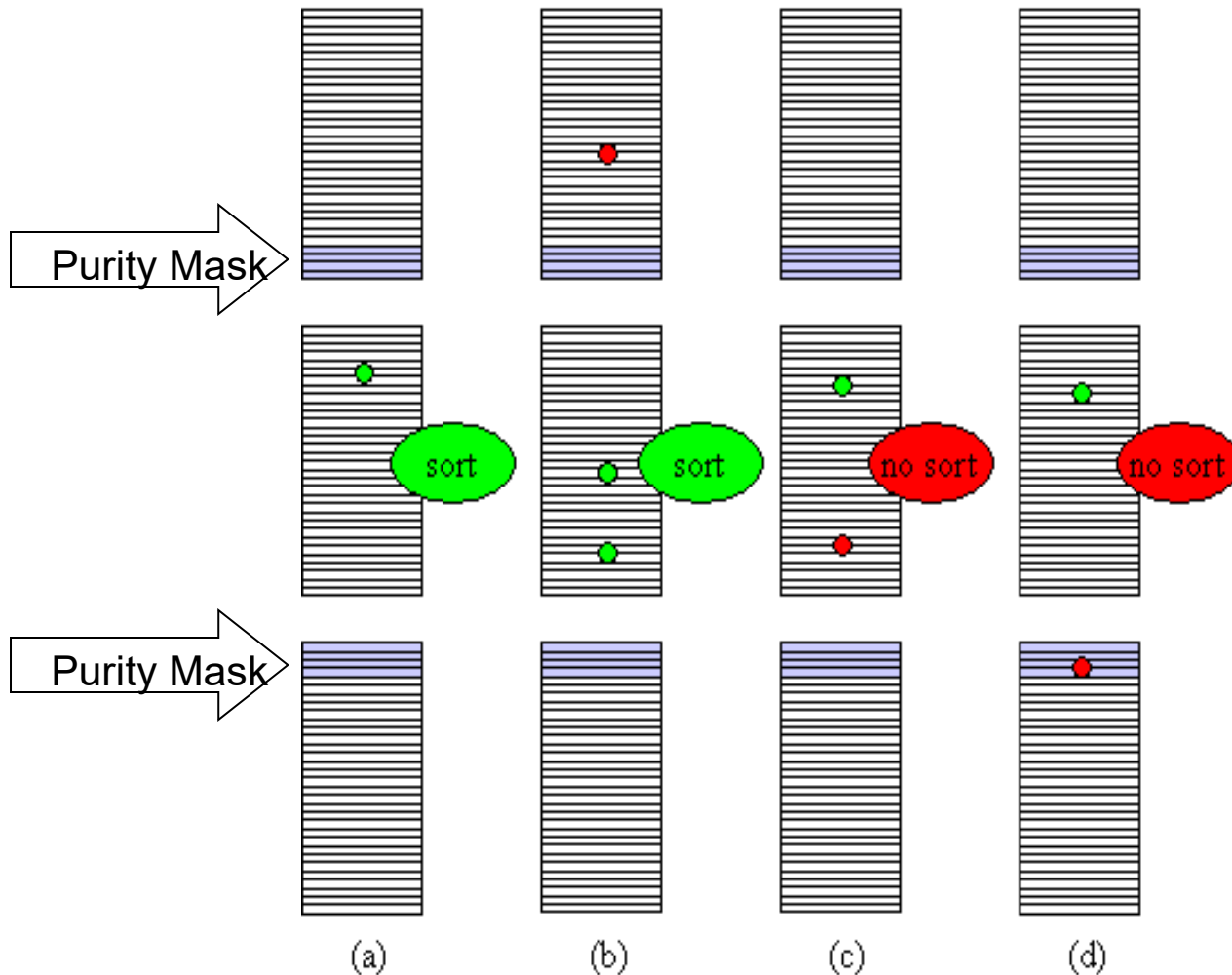

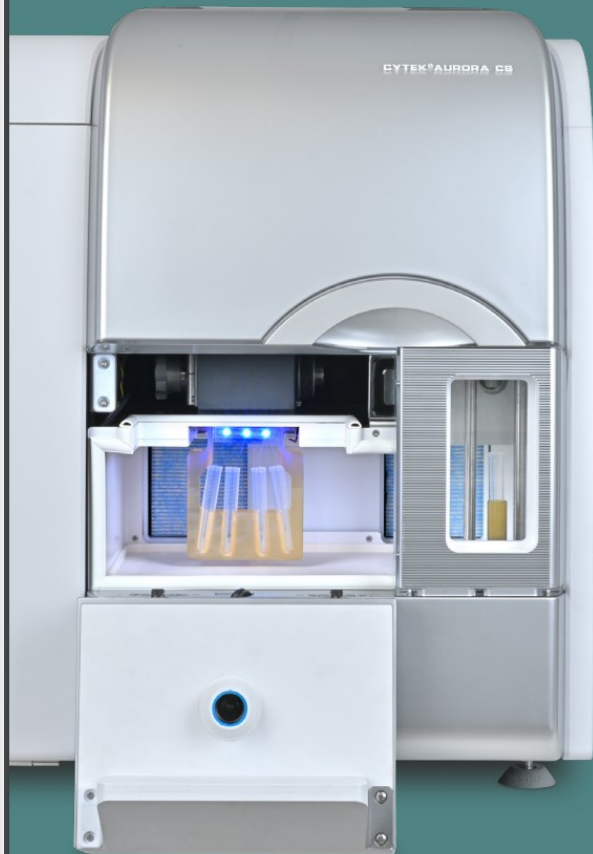

# Why Choose the Cytek® Aurora CS?

- So Many Colors  
**40 colors** demonstrated including fluorochromes with emission spectra in close proximity to each other.
- Exceptional Sensitivity and Resolution  
**Sensitivity redefined** using state-of-the-art optics and low-noise electronics.  
**Extract autofluorescence** and improve resolution of highly autofluorescent samples.
- New Levels of Flexibility  
**No need to reconfigure optical filters** for different fluorochromes.  
**Use any commercially available fluorochrome** excited by the onboard lasers.  
**Choose from a variety of sample input and collection devices** including 5 and 15 mL tubes for input and 96-well plates, 1.5 and 5 mL tubes for collection.
- Seamless Sorting Experience  
**Automated drop delay, sort monitoring, and clog detection** for a reliable sorting experience.  
**Comprehensive sort reports** automatically record settings used from every sort.  
**Assay transferability** from the Cytek Aurora system or conventional flow cytometers.

## Predefined and Custom Sort Modes

Select one of Cytek's predefined sort modes or create a custom defined sort mode to meet the needs of each user's sorting application.

- Purity  
Isolate the population of interest with little to no contaminants from other populations
- Enrich  
Prioritize retrieving a high number of the target population with reduced sort purity
- Multiway  
Intended for 4- or 6-way sorting for efficient drop deflection
- Single Cell  
Isolate single cells into 96-well plates
- Mixed  
A combination of Purity and Enrich modes
- Custom  
Adjust the sort decision settings to meet your application needs

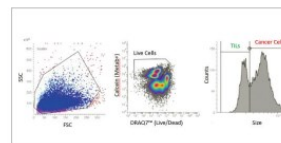

Label-free identification of TILs and cancer cells based on size

### Fluorescent localization

Reveal the spatial context of fluorescent signals hidden in flow cytometry. Track the subcellular movement of a protein across organelle boundaries within the cell, such as the NFκB translocation from the cytoplasm to the nucleus.

### Label-free sorting

Minimize sample preparation and sort precious, sensitive and transiently expressing cells using image-enabled FSC, SSC and light loss detectors to enable accurate cell characterization without fluorescent antibody labeling.

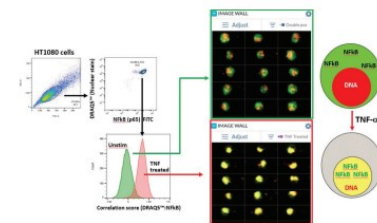

Configurations				
Number of spectral lasers	3	4	4	5
Number of fluorescent detectors	44	56	66	78
Total detectors	52	64	74	86
Lasers				
Ultraviolet laser (349 nm)			●	●
Violet laser (405 nm)	●	●	●	●
Blue laser (488 nm)	●	●	●	●
Yellow-green laser (561 nm)		●		●
Red laser (638 nm)	●	●	●	●

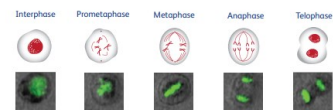

### Cell cycle analysis

Flow cytometry methods only rely on a single indicator of DNA content for cell cycle classification, which is incomplete. Image feature analysis can provide insight into DNA distribution information to differentiate the phases of the cell cycle.

### Cell-cell interaction

Reveal the spatial context of cells using image feature analysis to identify combinations of engaged cells. Distinguish between two cells that are coincident (passed through the interrogation point in close proximity) and true doublets (cells that are actually touching each other). Further image analysis can reveal receptor accumulation at the site of the cell-cell synapse (active synapse).

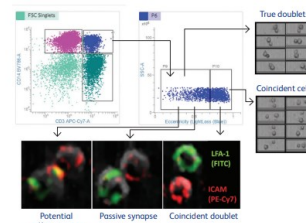



# Cell sorting - trendy

- Snadná obsluha
- Šetrná manipulace
  - On-chip technologie
- Velikost ↓ a bezpečnost ↑
- Microfluidic-based cell sorting
- Spectral cell sorting
- Image-based sorting
  
- Buoyancy Activated Cell Sorting (BACS™)
  - metoda, která používá částice s nízkou hustotou (mikrobubliny) pro flotační separaci.

## Elektronika a data

### File size considerations

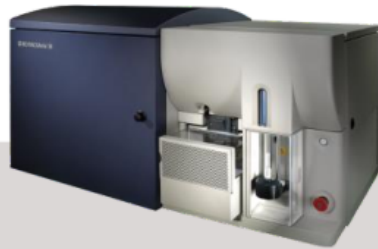

#### FCS data

- Saved for selected channels only
- H/W optional
- 10,000 events → ~2 MB for an 8-color experiment

Data management is vitally important for spectral and imaging cytometers



#### FCS data

- Saved for all channels
- A/H/W/TTP always saved
- 10,000 events → ~17 MB for any experiment

#### Image files

- All imaging features saved for selected imaging channels
- Larger cells will generate larger image files
- 10,000 events → ~1.5 GB for a PBMC experiment



# Sběr dat

- Data jsou sbírána jako “list” hodnot, pro každý “parametr” a pro každou “event” (buňku)
- každé měření z každého detektoru je označeno jako “parameter”

Flow Cytometry Standard data file format. FCS 3.1

[http://www.isac-net.org/images/stories/documents/Standards/fcs3.1\\_normativespecification\\_20090813.pdf](http://www.isac-net.org/images/stories/documents/Standards/fcs3.1_normativespecification_20090813.pdf)

Spidlen, J. *et al.* *Cytometry. Part A : the journal of the International Society for Analytical Cytology* 77, 97-100, (2010).



Date: 17-JUL-2015  
 System: Windows XP 5.1  
 Cytometer: FACSAriaII SORP (FACSAriaII)  
 File: 150717\_DU145 Ctrl.fcs  
 File URI: file://C:/Users/user/Desktop/install/Infinicyt/150717\_DU145%20Ctrl.fcs  
 -----  
 \$BEGINANALYSIS: 0  
 \$BEGINDATA: 4148  
 \$BEGINTEXT: 0  
 \$BTIM: 13:25:01  
 \$BYTEORD: 4,3,2,1  
 \$CYT: FACSAriaII SORP (FACSAriaII)  
 \$DATATYPE: F  
 \$DATE: 17-JUL-2015  
 \$ENDANALYSIS: 0  
 \$ENDDATA: 6055267  
 \$ENDTEXT: 0  
 \$ETIM: 13:28:55  
 \$FIL: 150717\_DU145 Ctrl.fcs  
 \$INST: IBP  
 \$MODE: L  
 \$NEXTDATA: 0  
 \$OP: fedr  
 \$PAR: 19  
 \$SRC: 150717  
 \$SYS: Windows XP 5.1  
 \$TIMESTEP: 0.01  
 \$TOT: 79620  
 APPLY COMPENSATION: TRUE  
 AUTOBS: TRUE  
 CREATOR: BD FACSDiva Software Version 6.1.3  
 CST BASELINE DATE: 03\_24\_2015 12:52:48 PM  
 CST BEADS LOT ID: 91725  
 CST SETUP DATE: 03\_25\_2015 03:01:55 PM  
 CST SETUP STATUS: SUCCESS WITH WARNING  
 CYTNUM: P5Y500001  
 CYTOMETER CONFIG CREATE DATE: 05\_13\_2013 01:32:45 PM  
 CYTOMETER CONFIG NAME: RF\_85u 45 psi\_SORP Aria\_5-laser (Zuv-6v-3b-5yg-3r)  
 EXPERIMENT NAME: DU145\_POPRO1\_LDYellow\_AF488\_AF594\_PE\_APCcy7  
 EXPORT TIME: 17-JUL-2015-14:30:11  
 EXPORT USER NAME: fedr  
 FJ\_FCS\_VERSION: 3  
 FSC ASF: 0.57  
 GUID: dc7612a3-65af-4520-bc0f-51d53273ebea  
 LASER1ASF: 0.86  
 LASER1DELAY: 0.00  
 LASER1NAME: Blue  
 LASER2ASF: 0.86  
 LASER2DELAY: -38.47  
 LASER2NAME: Red  
 LASER3ASF: 1.02  
 LASER3DELAY: 77.49  
 LASER3NAME: UV  
 LASER4ASF: 0.63  
 LASER4DELAY: 45.00  
 LASER4NAME: Violet  
 LASER5ASF: 0.83  
 LASER5DELAY: -76.49  
 LASER5NAME: YG  
 P10BS: 602  
 P10DISPLAY: LOG  
 P10MS: 0  
 P11BS: 38  
 P11DISPLAY: LOG  
 P11MS: 0  
 P12BS: 5  
 P12DISPLAY: LOG  
 P12MS: 0  
 P13BS: 1118  
 P13DISPLAY: LOG  
 P13MS: 0

Compensation Matrix

	Alexa Fluor 594-A	DAPI (405nm)-A	Alexa Fluor 647-A	PE-A	Alexa Fluor 488-A	APC-Cy7-A	Qdot 605-A
Alexa Fluor 594-A	100	0.42	1.53	1.94	0.02	0.32	9.95
DAPI (405nm)-A	1.1	100	0.27	0.05	0.01	0.08	0.98
Alexa Fluor 647-A	2.45	22.87	100	0.1	0.08	15.14	0.85
PE-A	440.67	0	0.14	100	8.03	0.03	32.23
Alexa Fluor 488-A	-0.01	0.09	0.01	0	100	0	0.05
APC-Cy7-A	0.01	0.04	2.67	0	0.05	100	0.01
Qdot 605-A	0	41.05	0	0	2.34	0	100

Parameters and Stains

Parameter (\$PnI)	Stain (\$PnS)	Range (\$PnR)	Bits (\$PnB)	Decades (\$PnE)	Gain (\$PnG)	Voltage (\$PnV)	Derived From
FSC-A		262144	32	0.0	1.0	280	
FSC-H		262144	32	0.0	1.0	280	
SSC-A		262144	32	0.0	1.0	210	
Alexa Fluor 594-A		262144	32	0.0	1.0	460	
Alexa Fluor 594-H		262144	32	0.0	1.0	460	
DAPI (405nm)-A		262144	32	0.0	1.0	650	
DAPI (405nm)-H		262144	32	0.0	1.0	650	
DAPI (405nm)-W		262144	32	0.0	1.0	650	
Alexa Fluor 647-A		262144	32	0.0	1.0	538	
Alexa Fluor 647-H		262144	32	0.0	1.0	538	
PE-A		262144	32	0.0	1.0	330	
PE-H		262144	32	0.0	1.0	330	
Alexa Fluor 488-A		262144	32	0.0	1.0	366	
Alexa Fluor 488-H		262144	32	0.0	1.0	366	
APC-Cy7-A		262144	32	0.0	1.0	700	
APC-Cy7-H		262144	32	0.0	1.0	700	
Qdot 605-A		262144	32	0.0	1.0	410	
Qdot 605-H		262144	32	0.0	1.0	410	
Time		262144	32	0.0	0.01		
Comp-Alexa Fluor 594-A		262144					
Comp-DAPI (405nm)-A		262144					
Comp-Alexa Fluor 647-A		262144					
Comp-PE-A		262144					
Comp-Alexa Fluor 488-A		262144					
Comp-APC-Cy7-A		262144					
Comp-Qdot 605-A		262144					

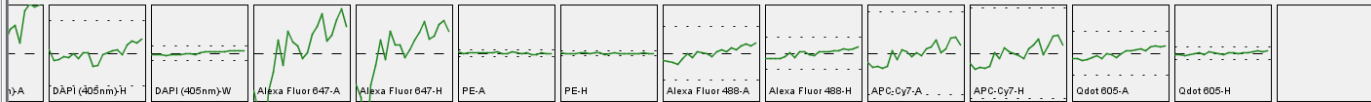



# Data Acquisition - Listmode

<i>Event</i>	<i>Param1</i> <i>FS</i>	<i>Param2</i> <i>SS</i>	<i>Param3</i> <i>FITC</i>	<i>Param4</i> <i>PE</i>
1	50	100	80	90
2	55	110	150	95
3	110	60	80	30

# Creation of a Voltage Pulse

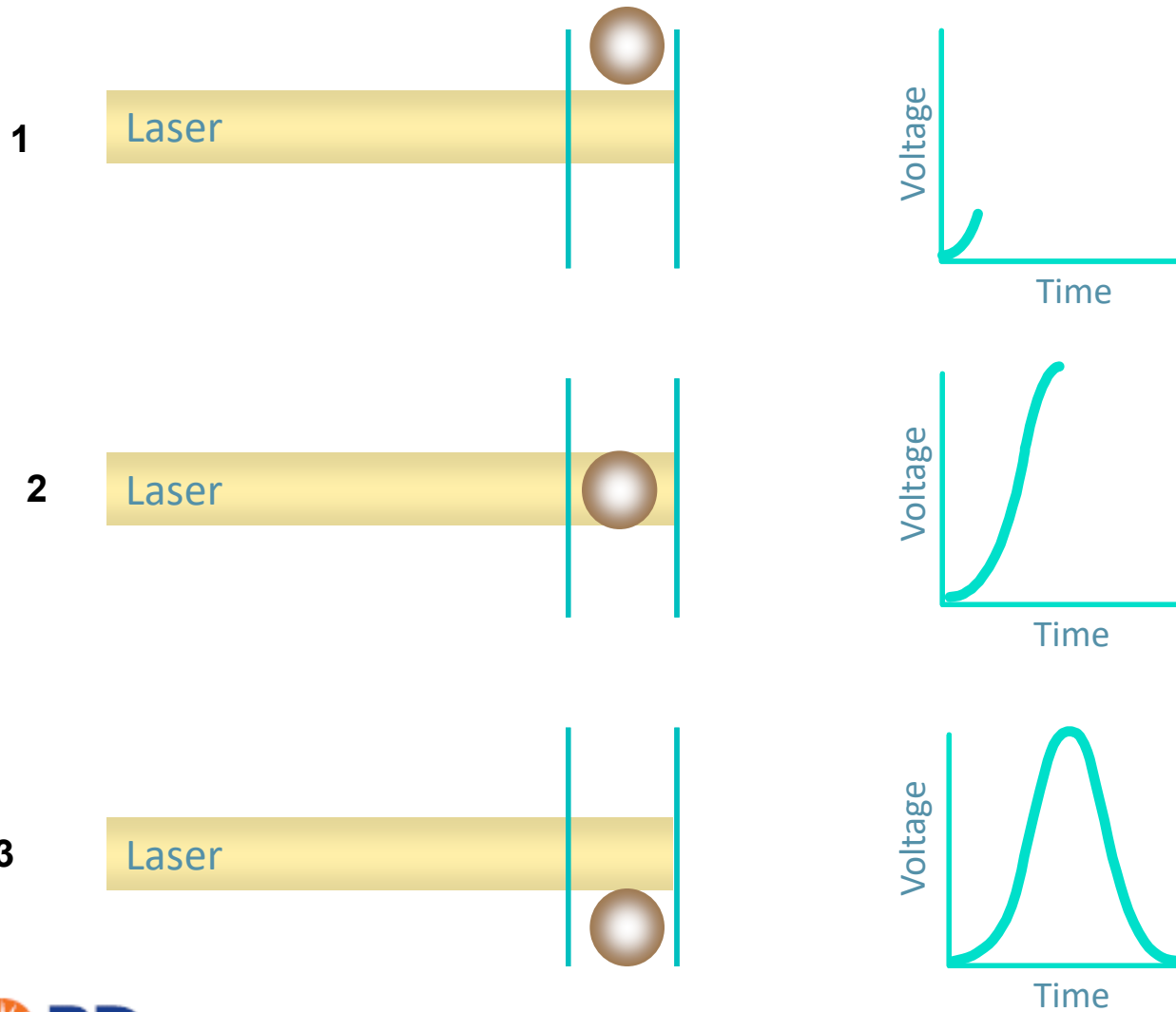

# Height, Area, and Width

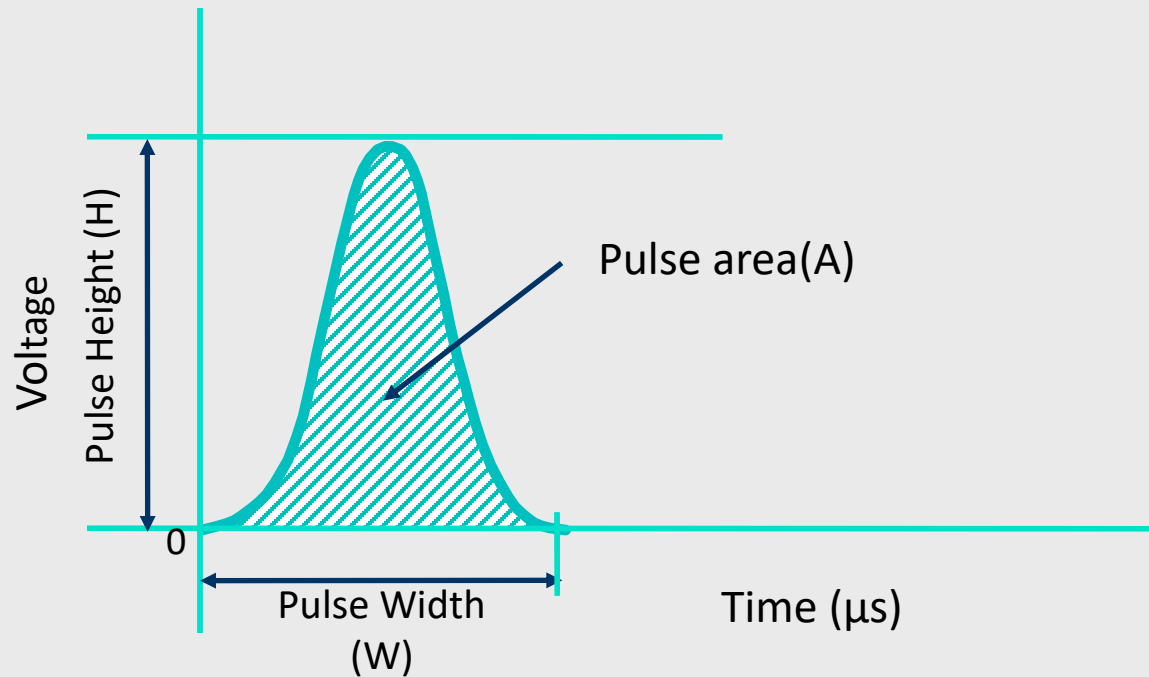

# Signal processing

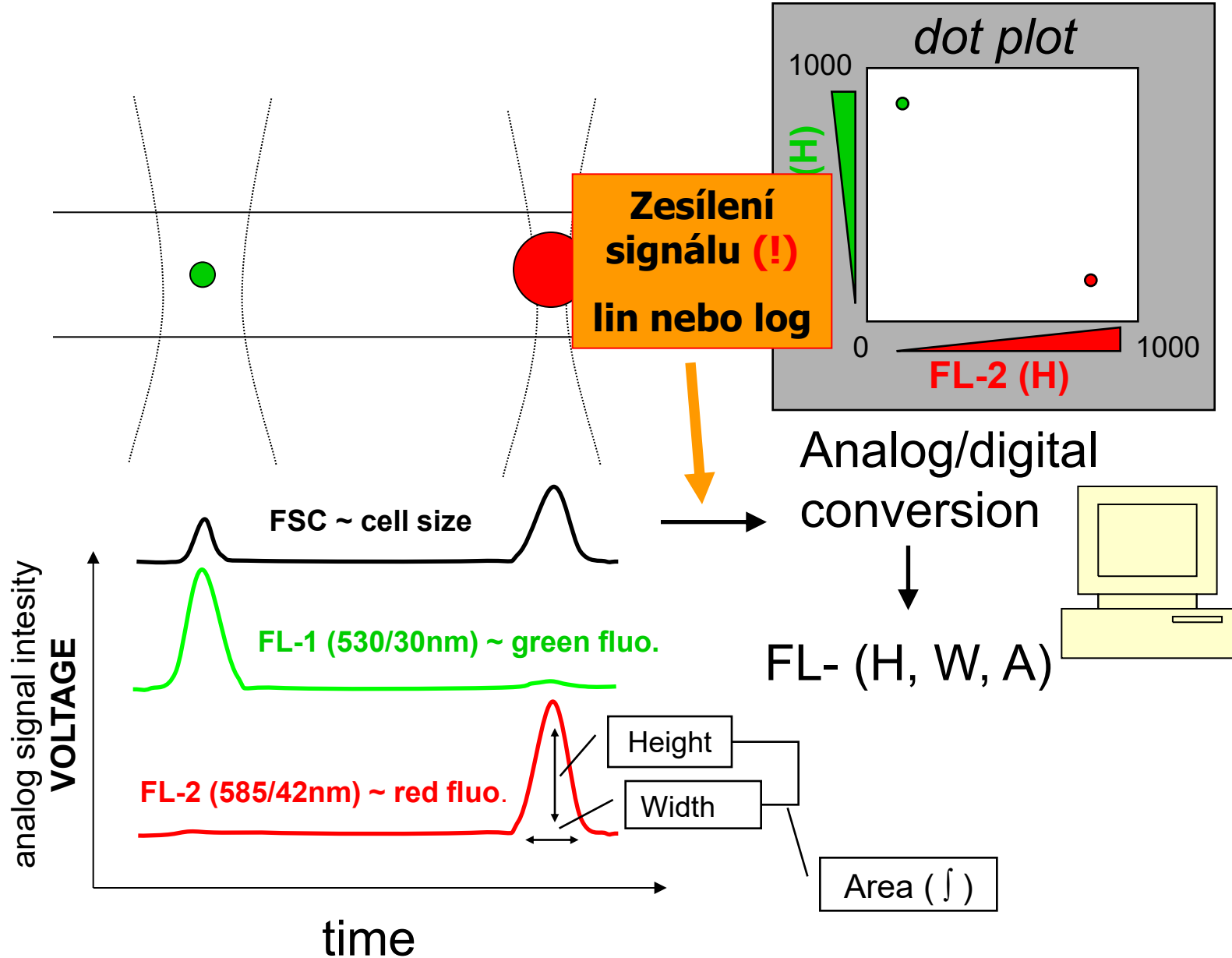

# Analog to Digital Converter

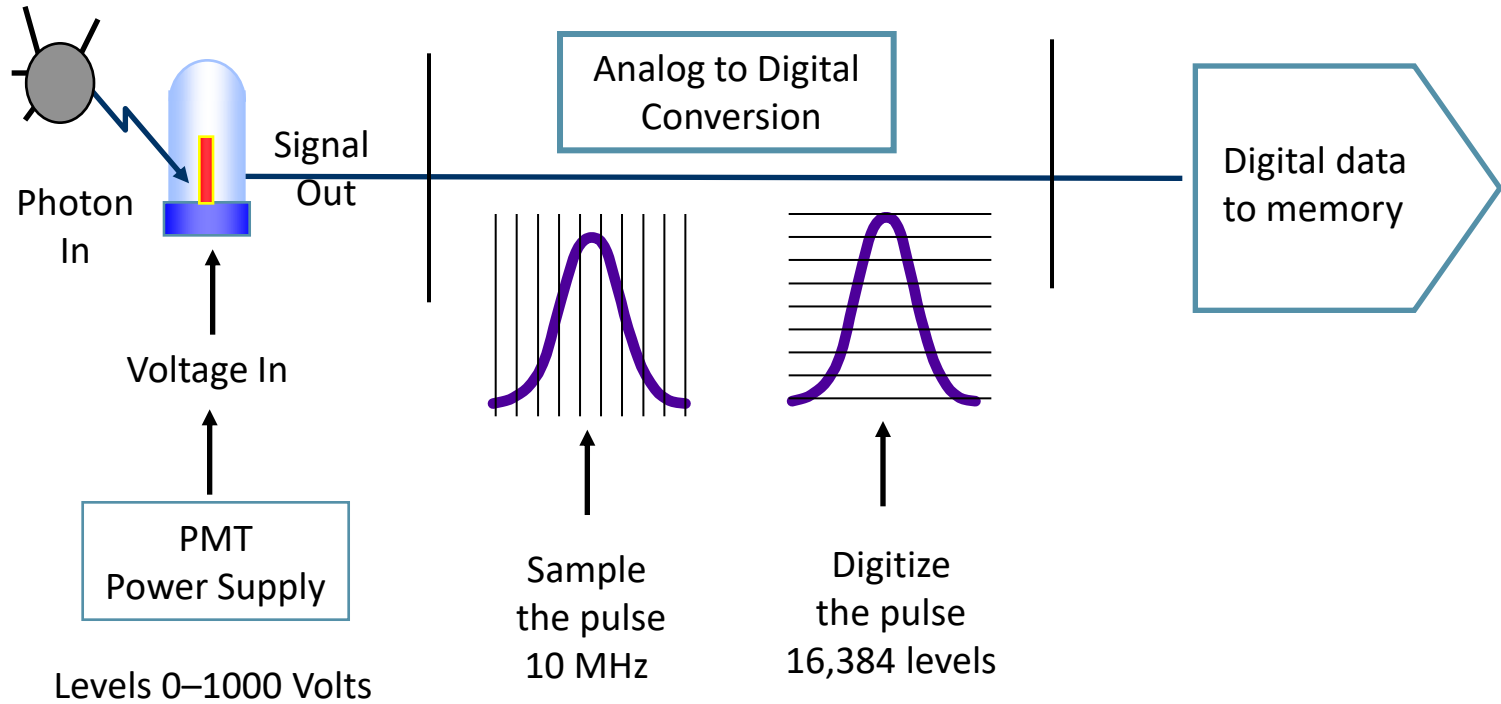

# Parameters

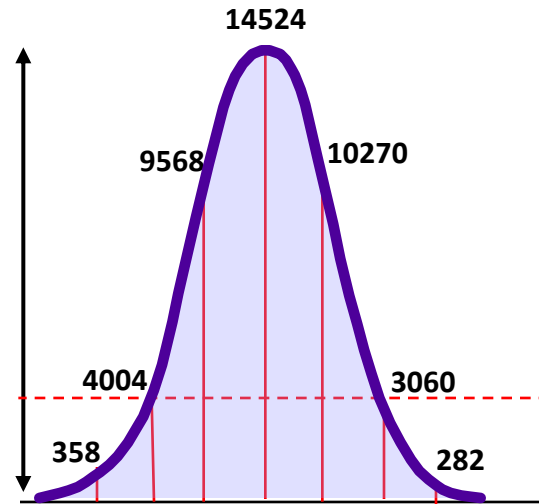

- Area: Sum of all height values
- Height: Maximum digitized value  
X 16
- Width: Area/Height X 64K

Data is displayed on 262,144 scale

$$2^8 = 256$$

$$2^{10} = 1024$$

# AD převodníky

Počet bitů	# kanálů	rozlišení
8	256	39.1 mV
<b>10</b>	<b>1024</b>	<b>9.77 mV</b>
12	4096	2.44 mV
14	16384	610 $\mu$ V
16	65536	153 $\mu$ V
<b>18</b>	<b>262144</b>	<b>38.1 <math>\mu</math>V</b>
20	1048576	9.54 $\mu$ V
22	4194304	2.38 $\mu$ V
24	16777216	596 nV

Full scale measurement range = 0 to 10 volts

ADC resolution is 12 bits:  $2^{12} = 4096$  quantization levels

ADC voltage resolution is:  $(10-0)/4096 = 0.00244$  volts = 2.44 mV

# Logaritmické zesílení & dynamický rozsah

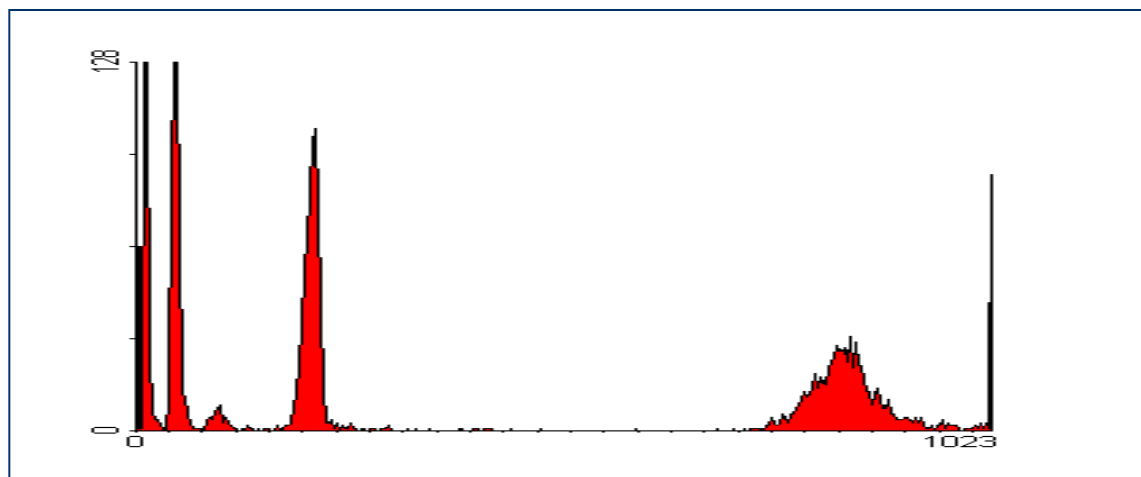

lin

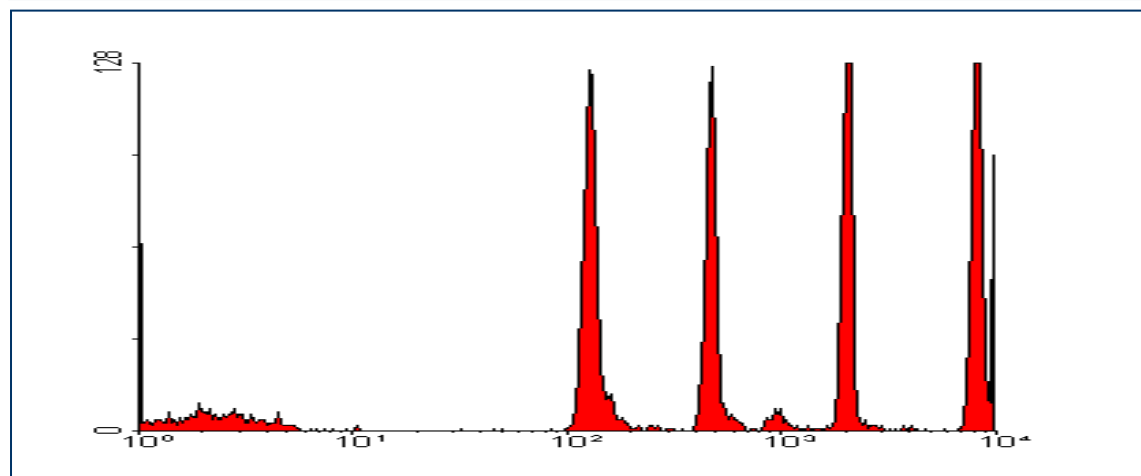

log





# Charakteristiky pulsu

- Pulsy detekované na průtokovém cytometru jsou analogové jevy detekované pomocí analogových zařízení
- Tyto pulsy trvají několik mikrosekund
- Pokud nemůžeme digitalizovat tento puls v reálném čase musíme kombinovat analog-digitalní zpracování pulsu
- běžně trvalo několik mikrosekund digitalizovat puls – to nebylo dostatečně průchodné pro vysokorychlostní sběr dat
- Nové – plně digitální systémy mohou digitalizovat puls přímo pomocí MHz frekvence



# Analýza dat

## ■ Zobrazení dat

- histogram
- dot plot
- isometric display
- contour plot
- chromatic (color) plots
- 3 D projection

## ■ Gating

# Jednoduché způsoby pro zobrazení dat

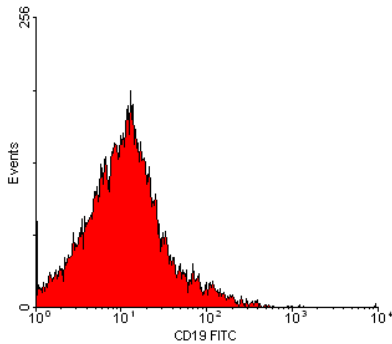

4Color TBNK + TruCO2.01

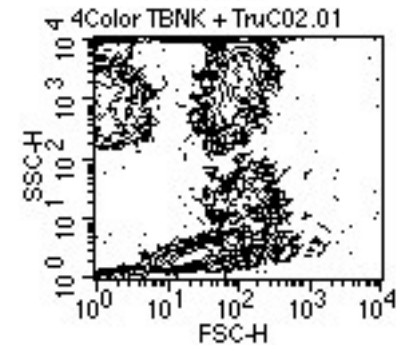
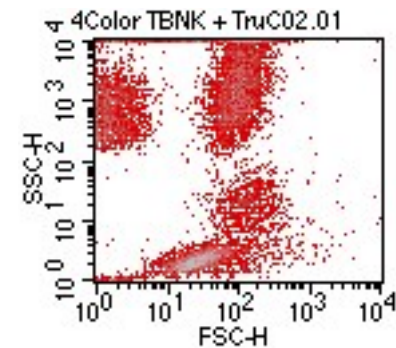
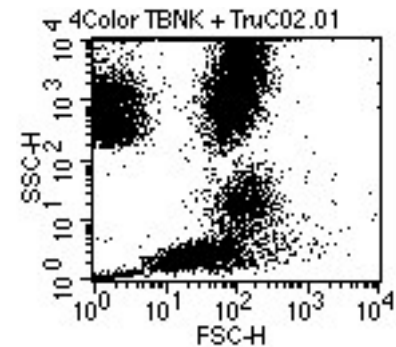
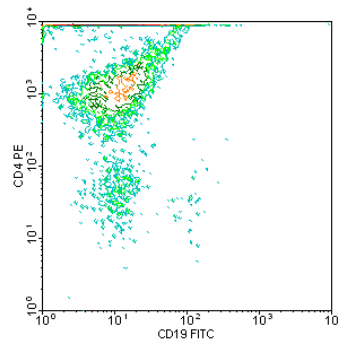
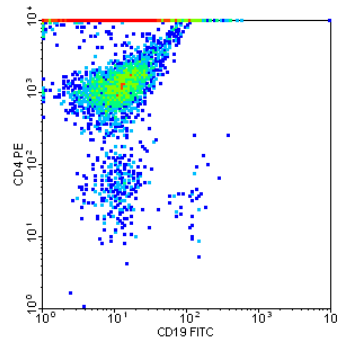
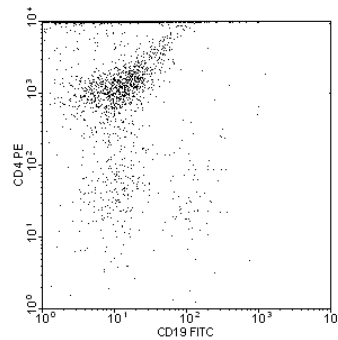
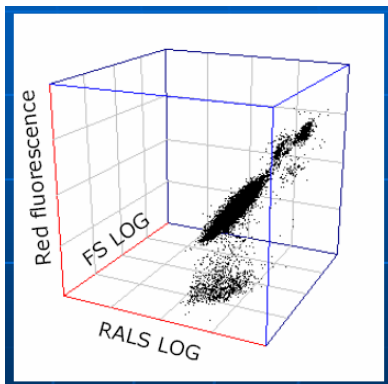

# Shrnutí

- Světlo, fluorescence
- Optické systémy
- Fluidní systémy
- Sorting
- Signál, data – základní princip

## Na konci dnešní přednášky byste měli:

1. znát základní principy rozptylu světla a
2. fluorescence;
3. vědět jaké zdroje světla se využívají v průtokové cytometrii;
4. a jakým způsobem je detekováno;
5. znát základní principy fluidních systémů a laminárního proudění.
6. Znat základní princip zpracování a vizualizace dat