

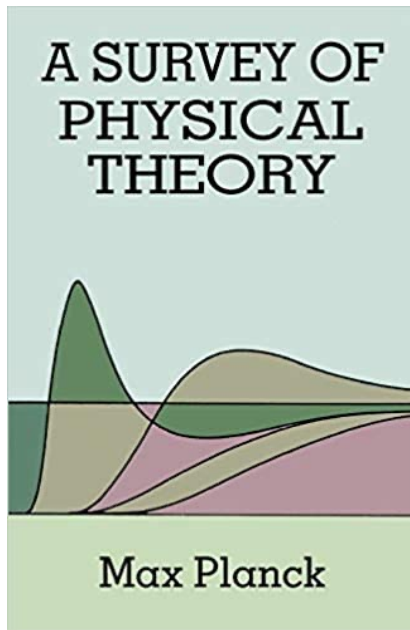

The Photon Theory of Light

“Life can only be understood backwards, but must be lived forwards”

Søren Kierkegaard (Danish philosopher
noted in his diary in 1843)



“----- knowledge must precede application,
and the more detailed our knowledge -----,
the richer and more lasting will be the results
which we can draw from that knowledge.”

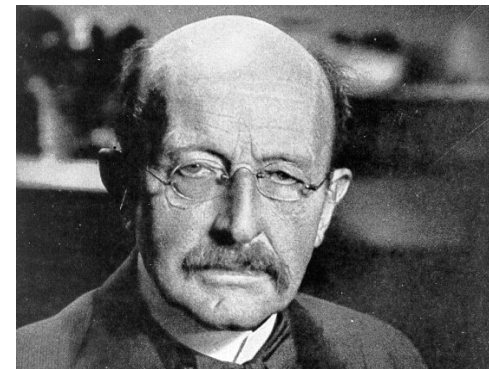

Nobel Prize, 1918

A historical account of the photon theory of light

“without taking account of its historical development, an existing theory often appears almost as if it had "fallen from heaven. However, the question of the development of a theory is important not only to satisfy our curiosity but also because much can be learnt from it for the future”.

G. Ludwig, Wave Mechanics, Pergamon Press, Oxford (1968)

The Physics of Light

While the terms "quantum physics" and "Theory of Relativity" are used casually every day, not many people know what they really mean. Yet these theories have had a profound impact not only on science and technology, but also on our world view.



This intriguing 6-part documentary series explores the concepts of physics from familiar theories, such as Newton's Law of Gravity, to the latest in scientific research, like string theory and M-theory. By connecting these studies with the medium of light, we can gain a deeper understanding not only of our immediate reality,

but of the unseen realities that are hidden beyond our perception. Starting with Einstein's Theory of Relativity, *The Physics of Light* explores the true nature of light, peers inside the atom, and looks ahead to the most cutting edge theories in physics.



EPISODES

Light and Time – The Special Theory of Relativity • Light and Space – The Theory of General Relativity
In Pursuit of Light • Light and Atoms • Light and Quantum Physics • Light and Strings

CHIEF PRODUCER YEON KYU LEE ADVISED BY SUNGJUN HONG PRESENTED BY YOUNG DOO JUNG

WRITTEN BY MI RAN KIM PRODUCED AND DIRECTED BY SO JOON KIM AND EYUNG JOON KIM

PAL1600 • APPROX. 5 HOURS ON TWO DISCS • WIDESCREEN • ENGLISH: STEREO • ENGLISH SUBTITLES

© 2015 Educational Broadcasting Systems. All rights reserved. Additional DVD material and packaging © 2015 PBS. All rights reserved. Distributed by PBS Distribution. Purchaser shall not publicly perform (except pursuant to the terms of any separately purchased public performance license) and shall not copy, alter, display or stream this DVD. Group-resale affiliated purchaser's agree to waive coverage immunity with respect to any violation of the foregoing. Image credits: © iStockphoto.com (person, cover), © iStockphoto.com (background, cover and back), © 2015 Educational Broadcasting Systems (text, images, back and spine). The PBS logo and BE MORE are registered trademarks of the Public Broadcasting Service, 15, 2012.

Thank you! Your purchase supports programming that inspires people to Be more.® Visit PBS.org.

ISBN: 978-1-4279-311-4



8 41887 02440 2



The Physics of Light

DVD
NON

Do Not
Put In
Book
Drop

QC
355.3
.P49
2015



DISC
SET
PAL1600

The Physics of Light



A 6-PART SERIES THAT ANSWERS THE MOST PROFOUND QUESTIONS OF OUR UNIVERSE

Reference Books

Thirty Years that Shook Physics, The Story of Quantum Theory,
George Gamow, 1965, Ch 1, pp 6-28.

The Great Physicists from Galileo to Einstein,
George Gamow, 1961, Ch 7, pp. 225-236.

Introducing Quantum Theory, A Graphic Guide, J. P. McEvoy and O. Zarate, 2013.

Boltzmann's atom: the great debate that launched a revolution in physics,
D. Lindley, 2001

Catching the Light, The Entwined History of Light and Mind,
A. Zajonc, 1993. (selected chapters)

Electrodynamics from Ampere to Einstein, Olivier Darrigol, Oxford Uni Press, 2000.

Theoretical Concepts in Physics, 3rd ed. Malcolm Longair, Cambridge Uni Press, 2020.

Reference Articles

- *The Nature of Light, Max Planck, A Survey of Physical Theory, Dover Publications, 1960, p. 89.*
- *The Origin and Development of the Quantum Theory, Max Planck, A Survey of Physical Theory, Dover Publications, 1960,. p.102.*
- *The History of Modern Physics: Vol 12, The Conceptual Development of Quantum Mechanics, Max Jammer, American Institute of Physics, 1989, pp 1-64.*
- *The Story of the Photon, N. Mukunda, Resonance, March 2000, p. 35.*
- *Black-Body Radiation, G. S. Ranganath, Resonance, Feb 2008, p. 115.*
- *The Particle Nature of Radiation: Photon, Optics, 6th ed. A. Ghatak, Mc Graw Hill, 2017, Ch 25, p. 25.3*

Modern science starts with Greeks

Socrates, Plato, and Aristotle

The Ancient Greeks are seen, in the west, as our intellectual forefathers. From Greece was born philosophy, drama, western artistic aesthetics, geometry, etc., etc.

Matter is made up of **four elements**

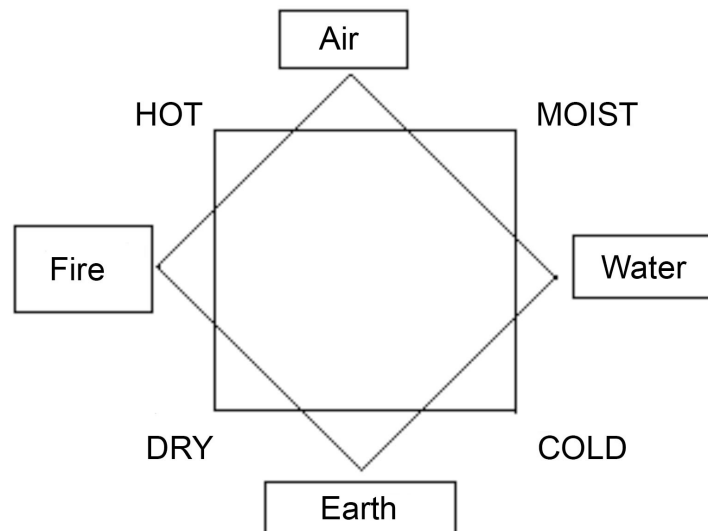

Asians and Arabs had their own ideas

The Indian View of the Universe

(*Taittirīya Upanishad* and *Aitareya Upanishad*, 6th century BC)

Five interconvertible elements make up the earth

Pancha Bhoota (Sanskrit: पञ्चभूत), five great elements, which, according to Hinduism, is the basis of all cosmic creation.

- **Prithvi** (Sanskrit: पृथ्वीः, Earth),
- **Jal** (Sanskrit: अपः, Water),
- **Agni** (Sanskrit: अग्नि, Fire),
- **Vayu** (Sanskrit: वायुः, Air),
- **Akasha** (Sanskrit: आकाश, Space).

Indian View: Tejas, Light and Fire

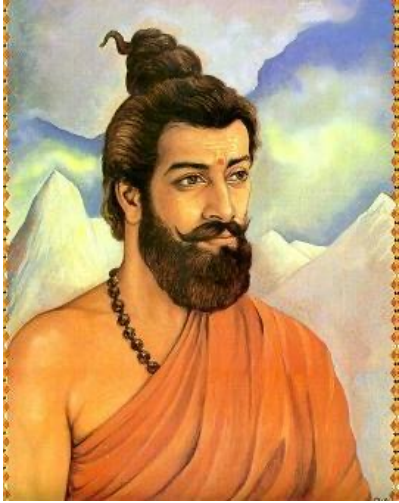

Acharya Kanada (Kashyap)
The Father of Atomic Theory

Vaiśeṣika Sūtra

Vatsayana, The Nyaya School

Between 6th and 2nd century BCE

- Light has no taste, no smell and no gravity.
- Light and heat are different forms of the same, Tejas.
- Light (Tejas) is constituted by infinitely small particles, something smaller and different than ‘anu or paramanu’ (atoms).
- These particles radiate themselves in all directions from their source and with inconceivable velocity.
- Light is the root, the nourisher, and the supporter of the tree of life.

Greek View: Light is made up of particles



Democritus

c. 460 – c. 370 BC

Sunlight is presumably, like fire, composed of small, swift-moving round atoms.

Vision occurs by means of the images flowing from objects. We see by the impact of images on the eye.

The air through which the object's image moves is infused with light particles from the sun and is imprinted on the eye.

Greek View: Light is made up of particles



Euclid, 300-265 BC



Euclid's *Optics*, 300 BC

“The light and heat of the sun are composed of minute atoms which, when they are shoved off, lose no time in shooting right across the interspace of air in the direction imparted by the shove.”

Euclid's view of vision: Eye to the object

- According to Euclid, the eye sees objects that are within its visual cone. The visual cone is made up of straight lines, or visual rays, extending outward from the eye. Visual rays is a cone of which the vertex is at the eye and the base at the surface of the objects seen.
- These visual rays are discrete, but we perceive a continuous image because our eyes, and thus our visual rays, move very quickly.
- That those things are seen upon which visual rays fall and those things are not seen upon which visual rays do not fall.

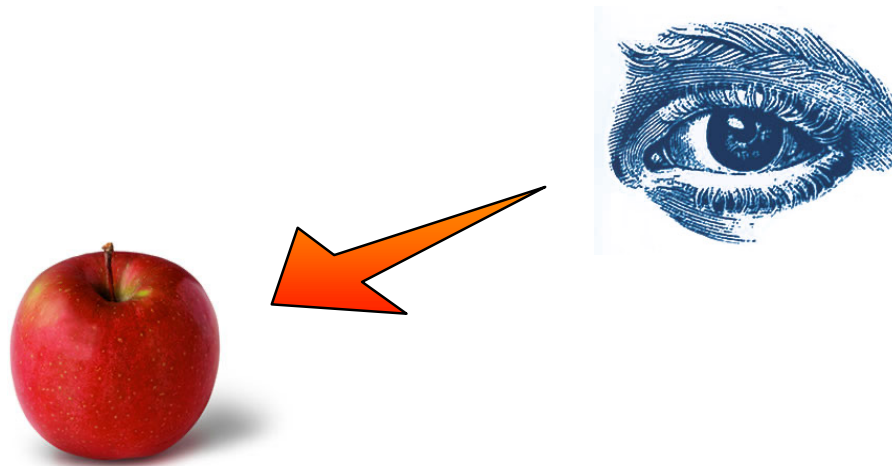

Middle eastern ancient (Christian) view of the universe

In the beginning God created the heavens and the earth.

Now the earth was formless and empty, darkness was over the surface of the deep, and the Spirit of God was hovering over the waters.

And God said, "Let there be light," and there was light.

God saw that the light was good, and he separated the light from the darkness.

God called the light "day," and the darkness he called "night."

Genesis 1:3-5

Arabic view: Ḥasan Ibn al-Haytham on vision



Ḥasan Ibn al-Haytham
965-1040 AD

Euclid
~300-265 BC

Democritus
c. 460 – c. 370 BC

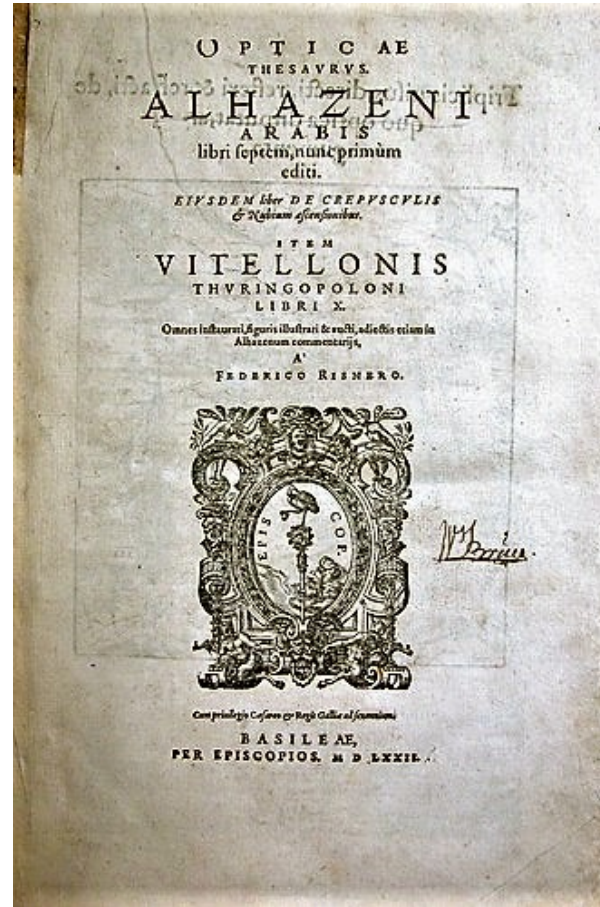

Book of Optics
7 volumes

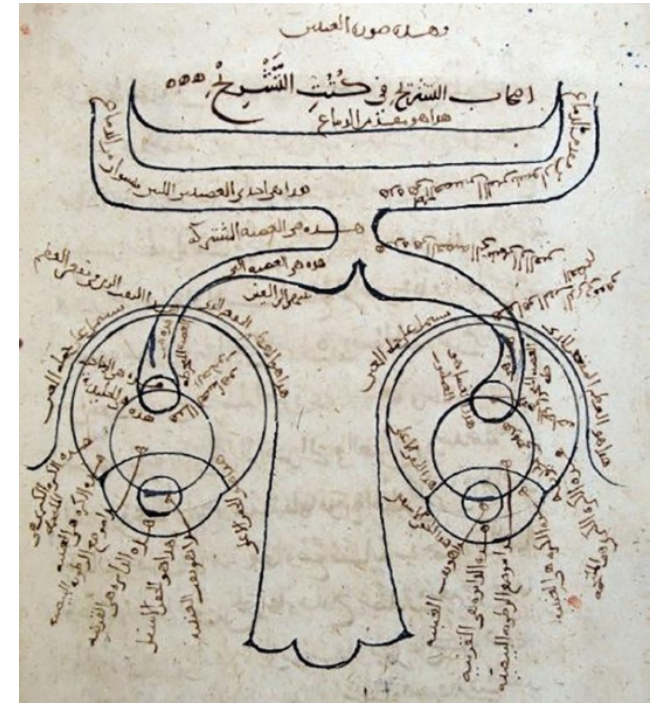

Eye to brain

Hasan Ibn al-Haytham on light and vision

Light travels in straight lines

Vision occurs when light reflected from an object passes to one's eyes.

Vision occurs in the brain, rather than in the eyes.

The object sends an infinite number of rays of light to the eye, only one of these lines falls on the eye perpendicularly. All the rays other than the one that hits the eye perpendicularly are not involved in vision

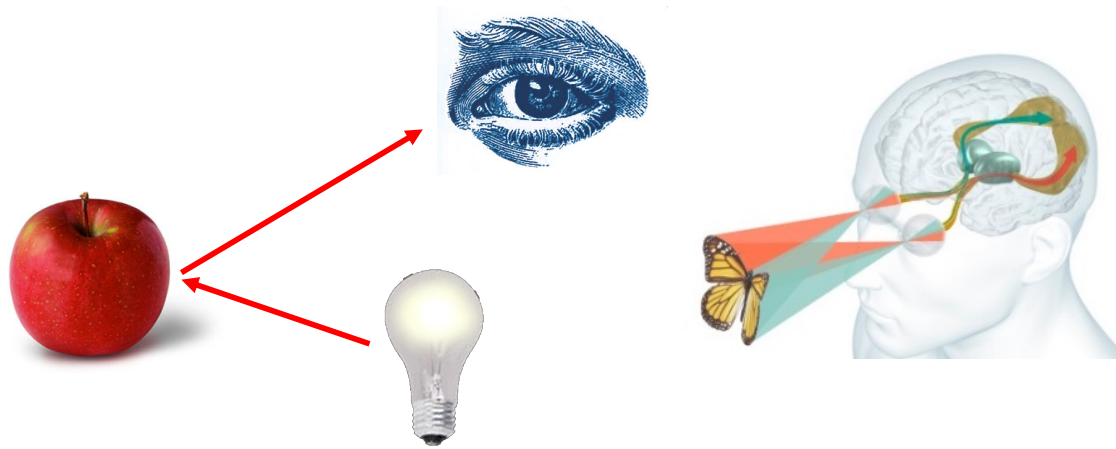

Hasan Ibn al-Haytham on light and vision

<https://www.youtube.com/watch?v=4Dk2CfO5PAY> Smithsonian

<https://www.youtube.com/watch?v=YUpocBrAc0> al-Haytham

<https://www.youtube.com/watch?v=SxJ2OC7iXo0> Ben Kingsley

Which is correct, how would you verify?

“eyes receive light reflected from objects, rather than emanating light themselves” --- *Hasan Ibn al-Haytham*

“light emanates from eyes & hits the objects” --- *Euclid*

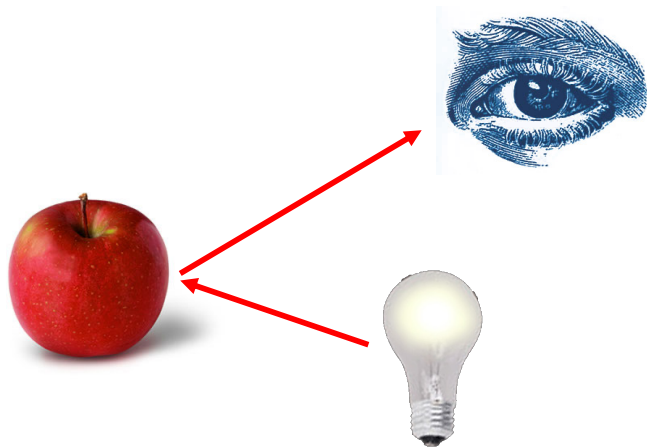

Hasan Ibn al-Haytham



Euclid

European view: What is Light



[Pierre Gassendi](#) (French)
1592–1655 AD

Ḥasan Ibn al-Haytham
965-1040 AD

Light is composed of [corpuscles](#) (particles of matter) which are emitted in all directions from a source.

Light particles travel at unimaginably high-speed (qualitatively correct).

Vision is a function of rays of light atoms or image-bearing atoms that are received by our internal apparatus for vision.

European view: What is sight?



René Descartes (French)
1596 –1650 AD

- The universe is filled with some material (named ‘**plenum**’), which pressed against the eyes. This pressure produces the phenomenon of sight. A bright object, like the Sun, generates pressure and that instantaneously is felt by the human eye.
- Objection: If sight is caused by the pressure of the plenum on the eye, then a person running at night should be able to see, because the runner’s motion would make the plenum press against their eyes.

René Descartes, *The World and Other Writings*,
English Translation, Cambridge Uni Press, 2004

Light diffracts: It is a wave



Francesco Maria Grimaldi
(Italian) 1618 –1663

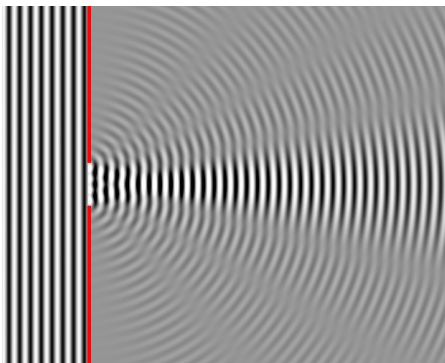

- Allowed a beam of sunlight to pass through a small aperture in a screen and noticed that it was diffused in the form of a cone. The shadow of a body placed in the path of the beam was larger than that required by the rectilinear propagation of light.
- Light is propagated or scattered not only directly and by reflection and refraction, but also in a certain other mode, namely by diffraction.
- **Diffraction** describes the event of waves encountering an obstacle and the consequential bending around the object.

Light diffracts

Diffraction is the bending of a wave around the edges of an opening or other obstacle.

In 1678, Huygens proposed every point on a wavefront is a source of **wavelets** that spread out in the forward direction at the same speed as the wave itself. The sum of these secondary waves determines the form of the wave at any subsequent time. The new wavefront is a line tangent to all of the wavelets.



Christian Huygens (Dutch)
1629 to 1695

Francesco M. Grimaldi
(Italian) 1618 –1663

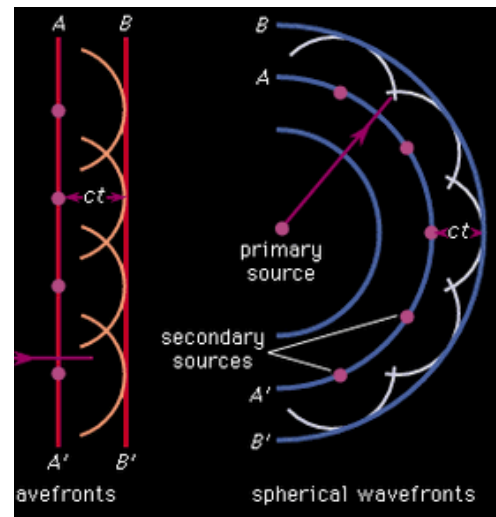

Light bends around corners

For plane waves entering a single slit, the waves emerging from the slit start spreading out, diffracting. The extent of spread depends on the slit opening size.

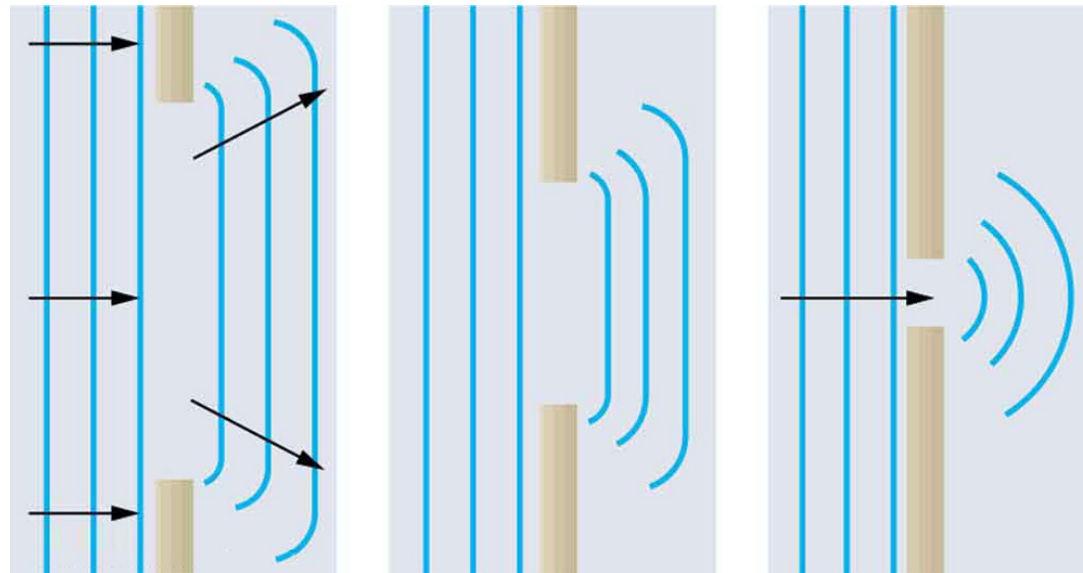

The edges of the wavefront bend after passing through the opening. The amount of bending is more extreme for a small opening, consistent with the fact that wave characteristics are most noticeable for interactions with objects about the same size as the wavelength.

Factors controlling light bending around corners

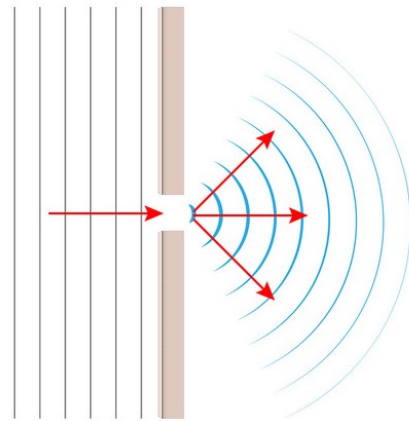

Wave impinges on a narrow slit

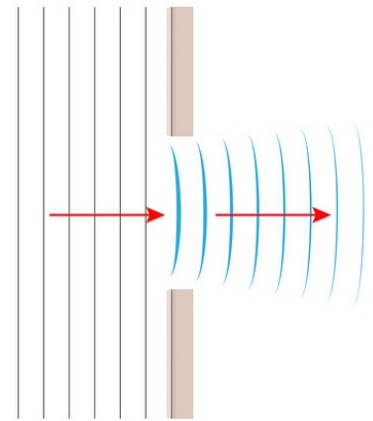

Wave impinges on a broad slit

- **Amplitude** – for any diffraction to occur, the incident waves must have a higher amplitude than the slit width. If the wave is smaller than the slit width, no diffraction will occur.
- **Slit Width** – Assuming an incident plane wave, decreasing the slit width will make diffraction more dramatic, and increase the angle at which the waves spread from the slit.
- **Wavelength** – Decreasing wavelength, or increasing frequency has a similar effect as increasing the slit width. A lower wavelength decreases the diffracted angle

Mechanism of diffraction

Factors controlling light bending around corners

Different amplitude and wavelength

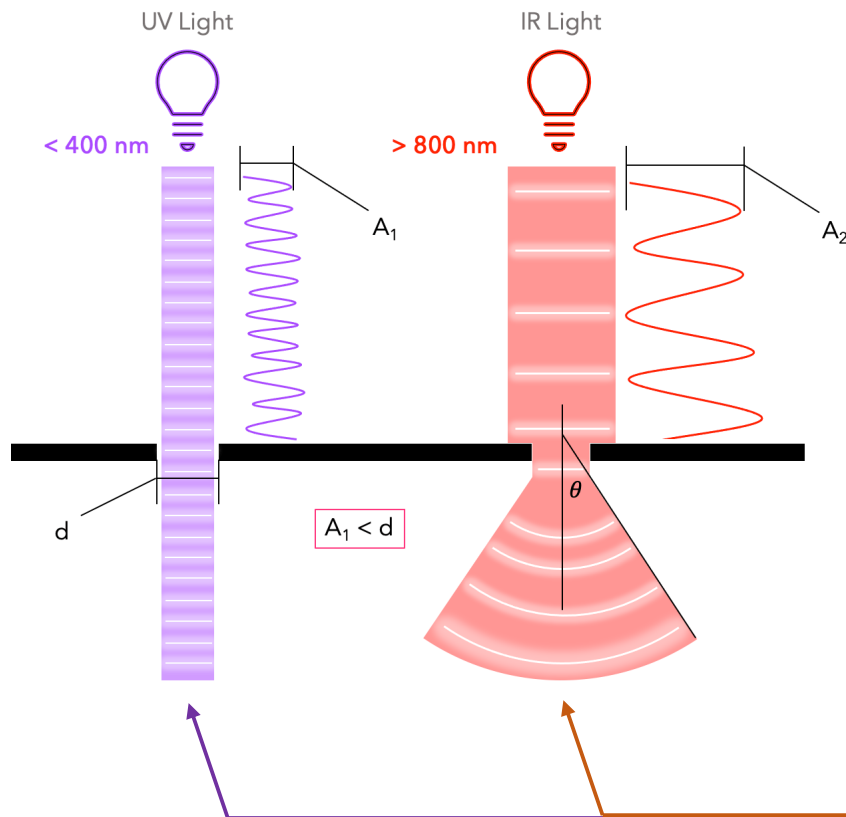

Same amplitude and different wavelength

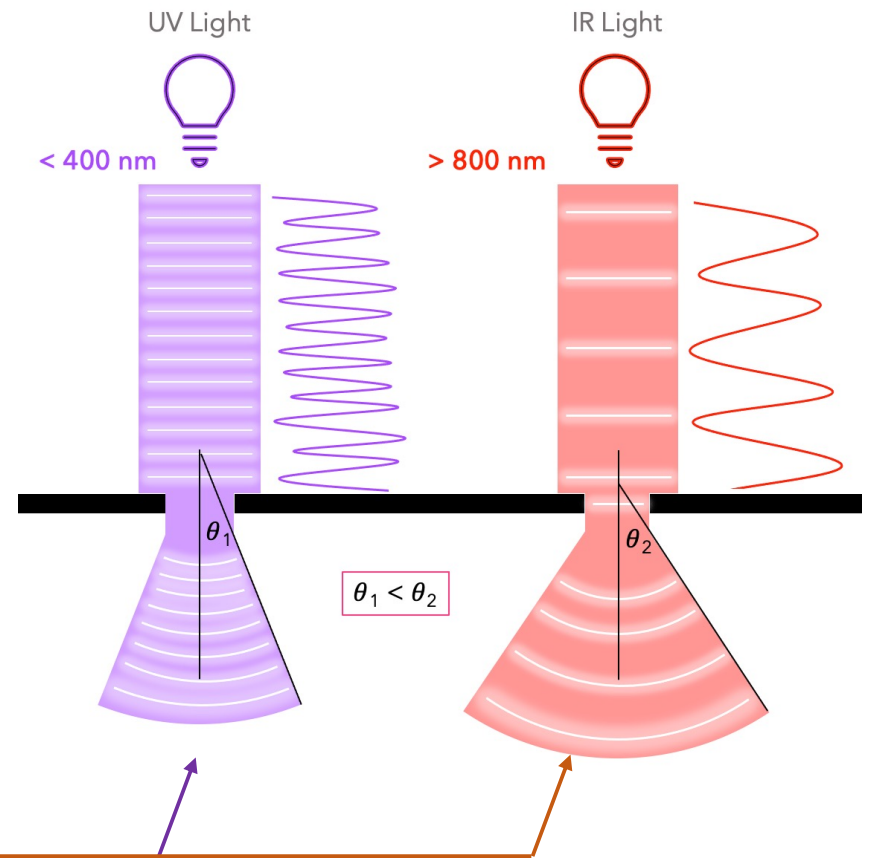

Difference between light and sound

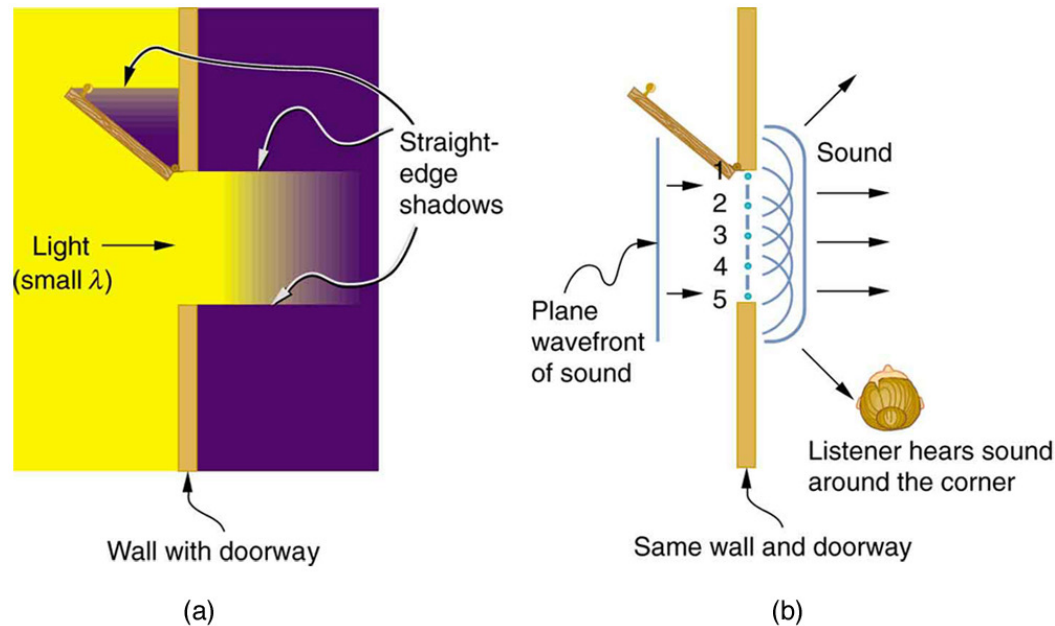

- Light passing through a doorway makes a sharp outline on the floor. Since light's wavelength is very small compared with the size of the door, it acts like a ray.
- (b) Sound waves bend into all parts of the room, a wave effect, because their wavelength is similar to the size of the door.

Rain drops, rainbow and colors

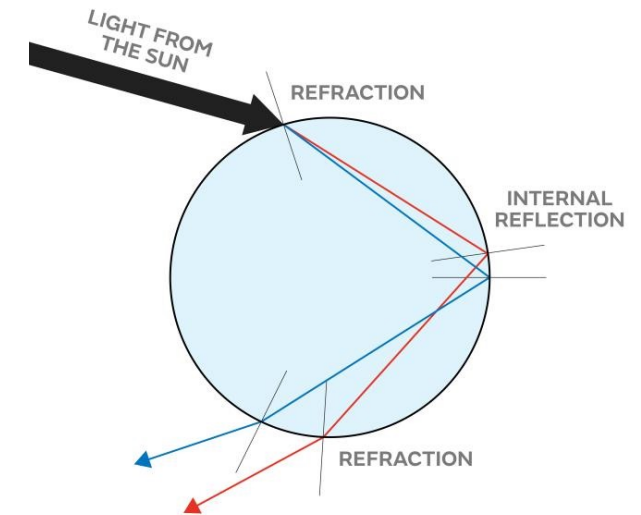

“Others have seen him (Sun) riding in wisdom on his chariot, with seven colors as horses and six wheels to represent the whirling spokes of time”.

*The Prashna Upanishad
(1-4 century BC)*

Light travels in a straight line: It is a particle

Corpuscular theory of light

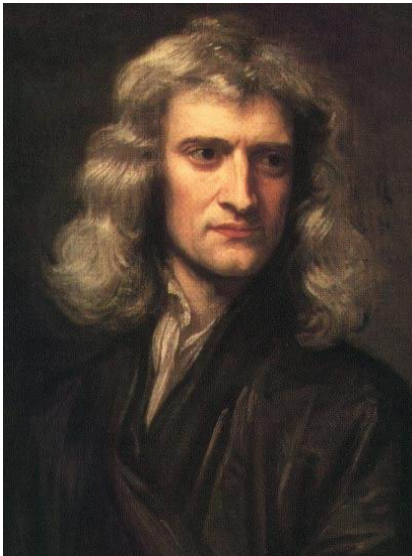

Sir Isaac Newton
(1643-1727)

René Descartes
1596 –1650 AD

[Pierre Gassendi](#)
1592–1655 AD

Francesco M. Grimaldi
1618 –1663

Christian Huygens
1629 to 1695

Sounds are propagated as readily through crooked pipes as through straight ones. But light is never known to follow crooked passages nor to bend into the shadow.

Light is a particle because the periphery of the shadows it created was extremely sharp and clear.

Newton argued that the geometric nature of *reflection* and *refraction* of light could only be explained if light were made of particles, because waves do not tend to travel in straight lines.

Every source of light emits large numbers of tiny particles that are elastic, rigid, and weightless.

Light is impure-a mixture of visible and invisible parts



In **1665**, **Isaac Newton**, took a glass prism and held it up to a beam of sunlight streaming through the window. He saw the sunlight that passed through the prism spread out into the colors of the rainbow - red, orange, yellow, green, blue and violet. Thus he showed white light is in fact a combination of seven **visible** colors.



In **1800**, **William Herschel** discovered a form of light (or radiation) beyond red light, now known as infrared radiation. Herschel measured the temperature just beyond the red portion of the spectrum in a region apparently devoid of sunlight. To his surprise, he found that this region had the highest temperature of all. This region is now known as **infrared (IR)**.



In **1801**, **J. W. Ritter** made a significant discovery while investigating rays beyond the violet color in the light spectrum. During his experiments, Ritter observed that these rays were capable of darkening paper impregnated with silver chloride. They are now known as **ultraviolet (UV)** and due have the ability to induce chemical reactions.

Light is a particle ~500 BC to 1650

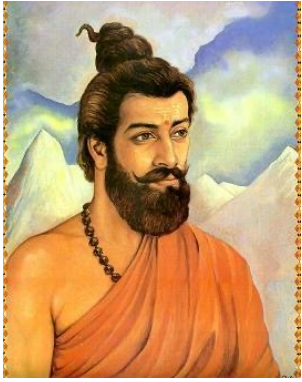

Kanada (Kashyap)

600-400 BC



Democritus

460-370 BC

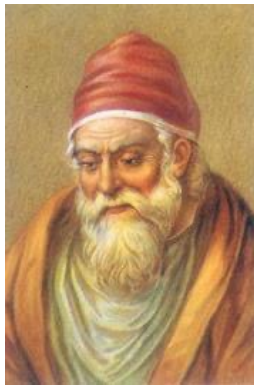

Euclid

360-285 BC



Pierre Gassendi

1592-1655 AD



al-Haytham

965-1040 AD



René Descartes

1596-1650 AD



Francesco M.

Grimaldi 1618-1663



Christian Huygens

1629 to 1695

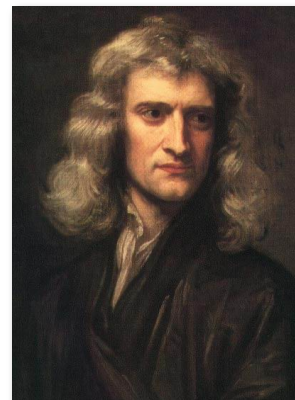

Isaac Newton

1643-1727



Robert Hooke

1635-1703



Thomas Young

1773 - 1829

Light is a wave ~ 1650s

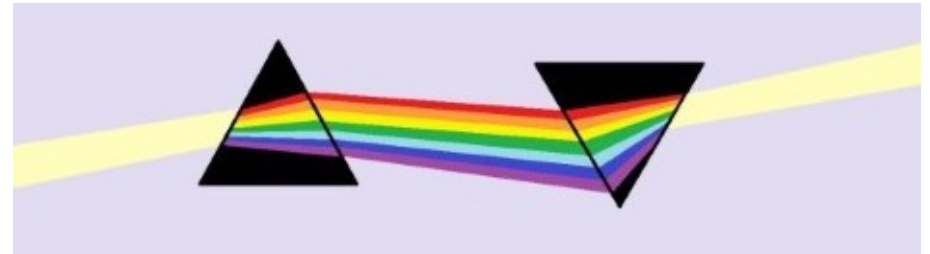

In the 1660s, Newton began a series of experiments with sunlight and prisms. He demonstrated that clear white light was composed of seven visible colors.

“If the Sun’s Light consisted of but one sort of Rays, there would be but one Color in the whole World”.

Newton (1660s)

Hooke (1635-1703) vs Newton (1643-1727)



Robert Hooke
1635-1703

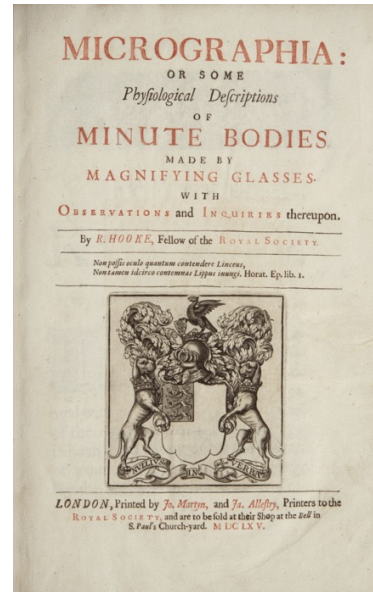

Micrographia
(1665)



Hooke-microscope
Hooke was an early one
to build and experiment
with microscopes

- Hooke opined that a combination of different amounts of red and blue originated the rest of the colors. This is different from Newton's suggestion that light is made up of seven colours.
- Hooke proposed light is a wave because it diffracts while Newton said it is a particle.”

What is light, particle or wave?

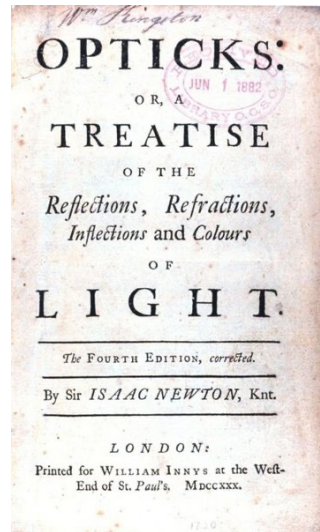
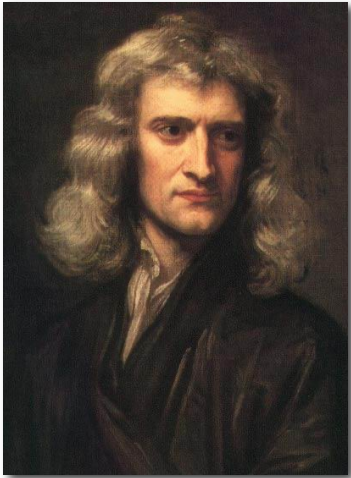

1704

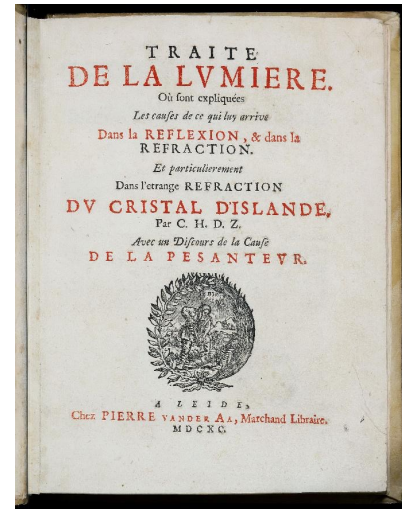

Treatise on Light (French)

1690



In 1678 Christian Huygens argued that light was a pulse traveling through a medium, a wave.

Because of Newton's enormous prestige, his support of the particle theory of light tended to suppress other points of view. This continued for 100 years.

What is light?

Kanada, Democritus, Euclid, Gassendi, Newton:

light is composed of a large number of particles

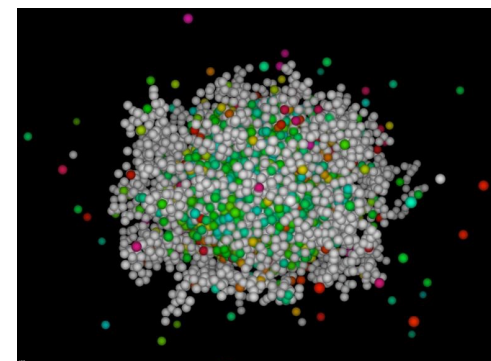
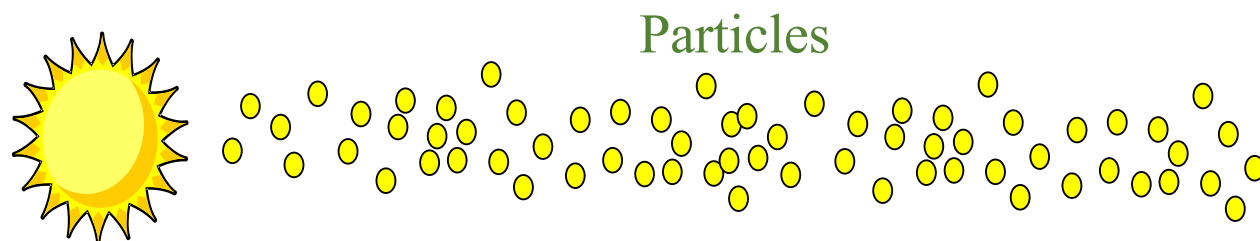

Grimaldi, Hooke and Huygens:

light is composed of waves

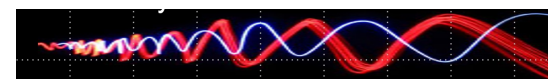
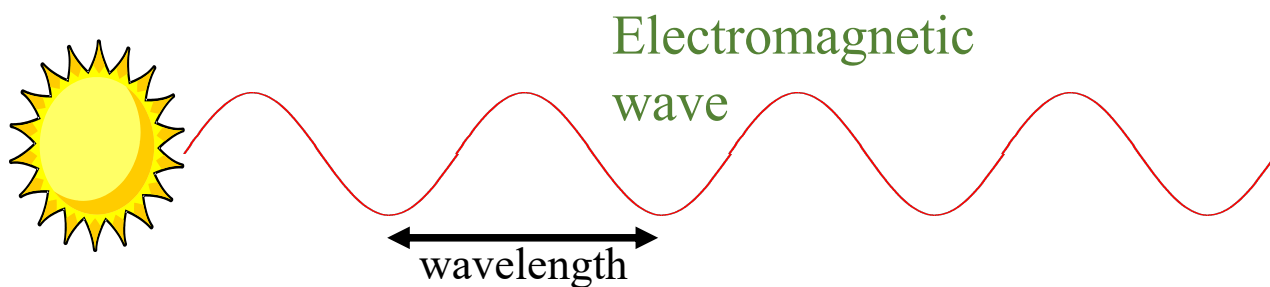

Light is ----



Isaac Newton

Seven colors that we can see (1665)

Seven colors plus one beyond red (*infra-red*) that we can't see (1800)



William Herschel



J. W. Ritter

Seven colors plus one beyond violet (*ultra-violet*) that we can't see (1801)

Light is a wave

French physicist Augustin-Jean Fresnel asserted in **1815** that light is a wave and mathematically proved the phenomenon of light interference. He also hypothesized that space is filled with a medium known as **ether** because waves need something that can transmit them.



Augustin-Jean
Fresnel
(1788 to 1827)



Thomas Young
(1773 to 1829)

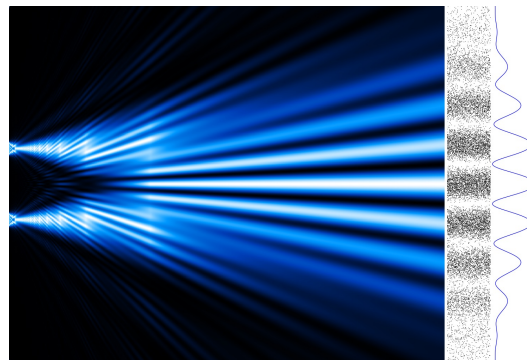

With [interference experiment](#), or [double-slit experiment](#), in **1817** Young demonstrated interference in the context of light as a wave.

Light is a wave: A new evidence



Thomas Young
(1773 to 1829)
(~200 yrs ago)

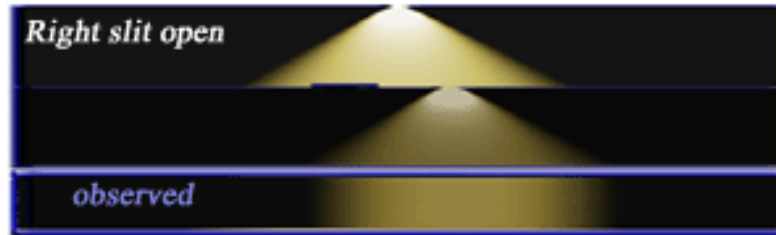

The bright and dark bands demonstrated that the slits were causing light waves to interfere with each other. Sometimes this interference is constructive and sometimes destructive. This leads to light waves adding together to create a bright patch and cancelling each other out creating dark patches.

Double-slit experiment demonstrated interference in the context of light as a wave

Interference of light is a common phenomenon

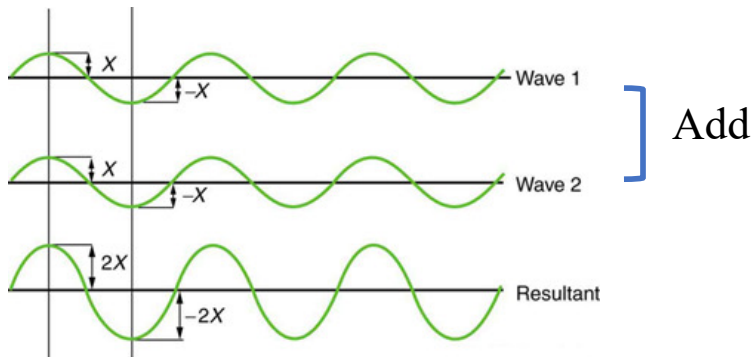
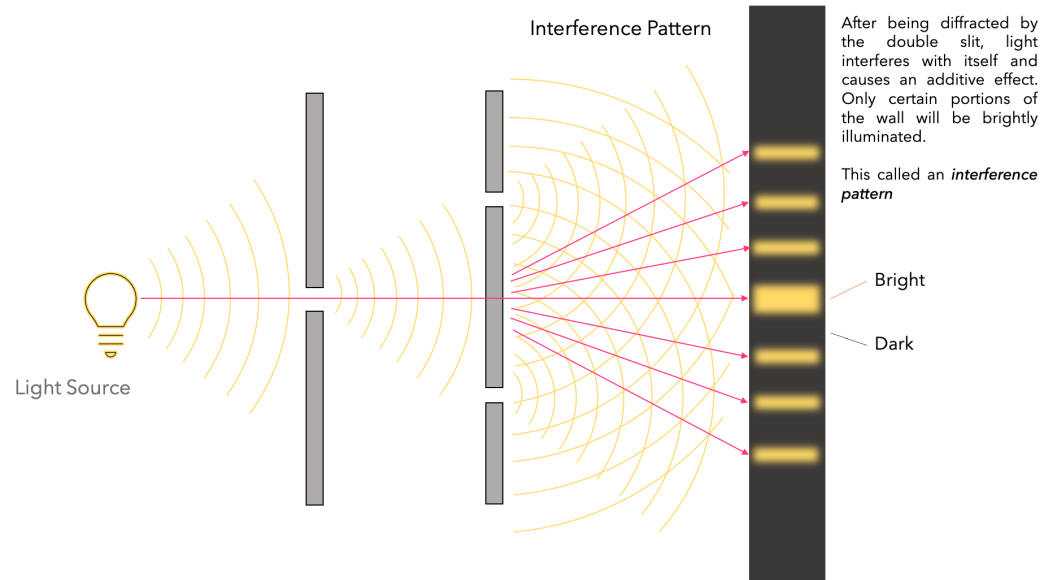

The interference of two waves. When in phase, the two waves create constructive interference resulting in a wave of greater amplitude.

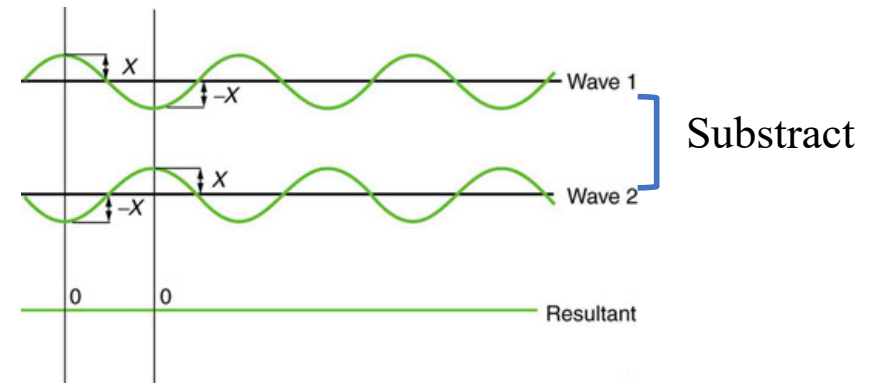

When 180° out of phase, they create destructive interference.

Web links

<https://www.youtube.com/watch?v=ak7GB74Qlug>

<https://www.olympus-lifescience.com/en/microscope-resource/primer/java/polarizedlight/emwave/>

<https://www.olympus-lifescience.com/en/microscope-resource/primer/lightandcolor/>

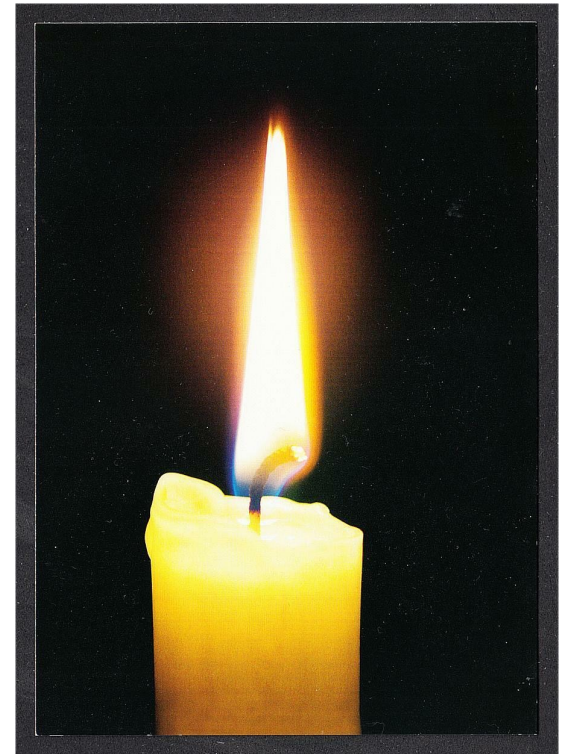

Wave or particle remains unresolved 500 BC to 1800 AD

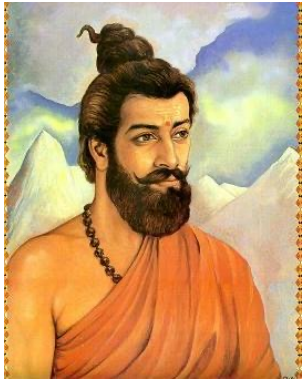

Kanada (Kashyap)
600-400 BC



Democritus
460 – 370 BC

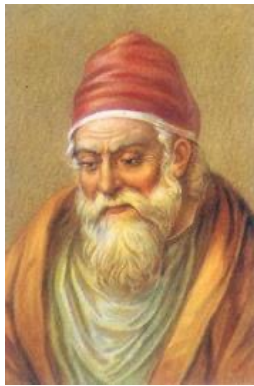

Euclid
300 –265 BC



al-Haytham
965-1040 AD



René Descartes
1596 –1650 AD



Pierre Gassendi
1592–1655 AD



Francesco M.
Grimaldi 1618 –1663



Christian Huygens
1629 to 1695

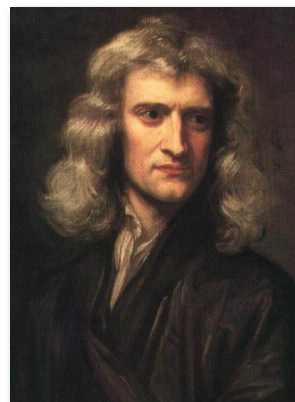

Isaac Newton
1643-1727



Robert Hooke
1635-1703



Thomas Young
1773 - 1829

What is light made up of?

Michael Faraday



The Electric Life of Michael Faraday, A. Hirshfield, 2006

Faraday Rediscovered, D. Gooding and F. A. J. L. James, 1985

Faraday, Maxwell, and the Electromagnetic Field: How Two Men Revolutionized Physics,
N. Forbes and B. Mahon, 2014.

Lecture by Sir John Thomas

<https://royalsociety.org/science-events-and-lectures/2017/12/genius-legacy-michael-faraday/>

The Beginning

- Born near London on Sep 22 1791; three siblings
- Father a blacksmith, mostly unemployed and unhealthy
- Mother from a family of farmers
- Deeply religious, Sandemanian sect of Christianity
- Educated in rudimentary reading, writing and arithmetic, age 5-13
- Took up a job at age 13 as an errand-boy and book-binder for a local shopkeeper (Mr. Riebeau)
- At the age of 18 he has to care for the family and took up a job under Humphry Davy in London

- *The Encyclopedia Britannica* – his source for electrical knowledge and much more
- *Conversations on Chemistry* – 600 pages of chemistry for ordinary people written by [Jane Marcet](#) based on Davy's lectures at the Royal Institution

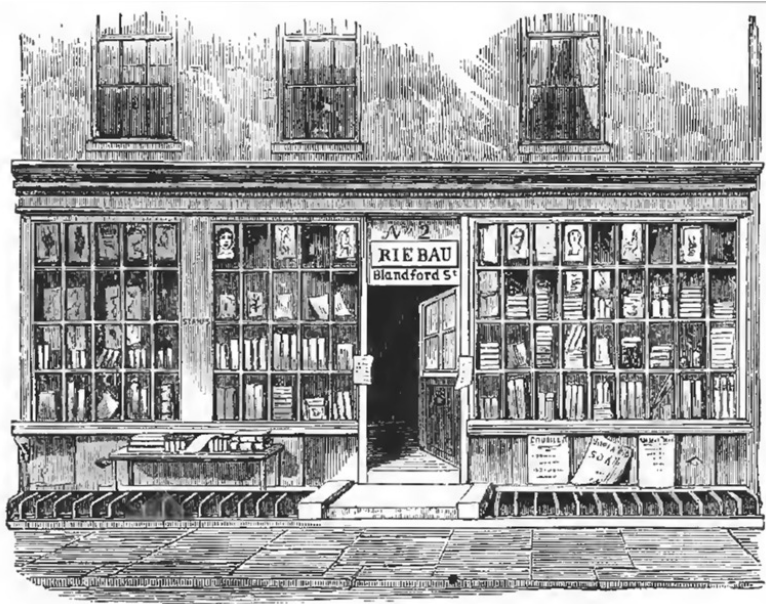

Davy's lectures at RI recorded



Jane Marcet, 1769-1858

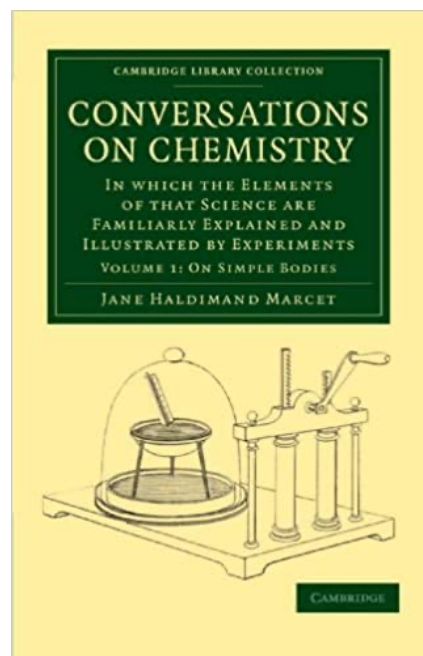

“the most wonderful and the most interesting phenomenon of nature are almost all of them produced by chemical powers”

Conversations on Chemistry, 1817

John Tatum's lectures (1772-1858) exposed Faraday to science

Tatum founded the [City Philosophical Society](#) in 1808 where [Faraday](#) and other local people received inspiration.

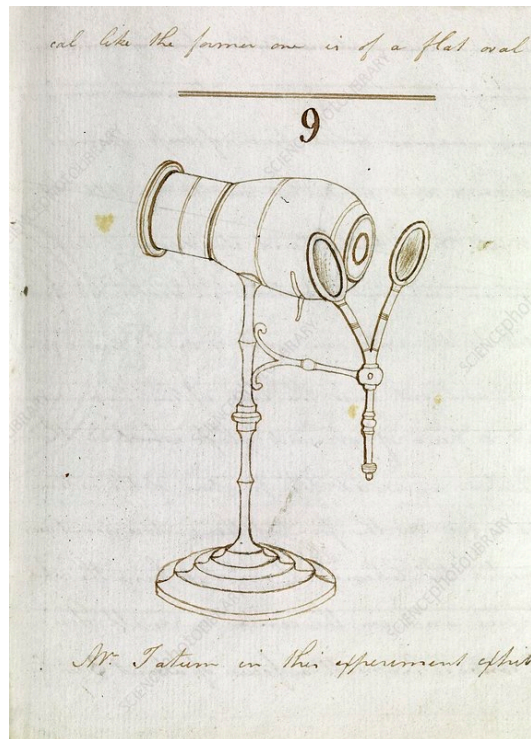

Faraday, a bookbinder's apprentice at the time, lacked a formal education and studied by reading books and attending lectures. He attended around 13 lectures by silversmith John Tatum (1772-1858) between February 1810 and September 1811. The notes Faraday made from these lectures formed four volumes and 300 pages and helped him start his career in science.

Getting Started

“My desire to escape from trade, which I thought vicious and selfish, and to enter into the service of Science, which I imagined made its pursuers amiable and liberal, induced me at last to take the bold and simple step of writing to Sir H. Davy, expressing my wishes, and a hope that if an opportunity came in his way he would favor my views; at the same time, I sent the notes I had taken of his lectures.” (1812)

Based on the letter Faraday wrote about the experience later in life after Davy's death to J.A. Paris. (1829)

Davy's encouraging reply to Faraday

“Sir,— I am far from displeased with the proof you have given me of your confidence, and which displays great zeal, power of memory, and attention. I am obliged to go out of town and shall not be settled in town till the end of January; I will then see you at any time you wish. It would gratify me to be of any service to you; I wish it may be in my power.

I am, Sir, your obedient humble servant,
H. Davy.”

Michael Faraday establishes that light is electromagnetic



1791-1867

Series of pioneering discoveries during 1821-1831

The First Electromagnetic Induction

The basis of electric power generation



A crude observation into a full-blown discovery.

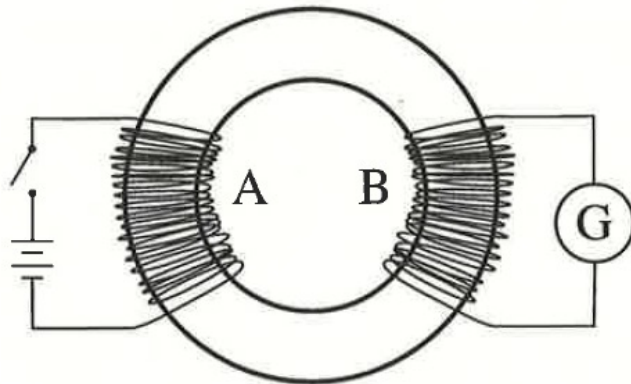

In the iron ring experiment the current in coil 'A' produces magnetism in the ring. While this magnetism is being produced, and consequently is in motion, it is able to produce a current in coil 'B'. When the magnetism is raised to a steady state it becomes stationary and the current in coil B disappears.

Electricity to Magnetism

Magnetism to Electricity

World's First Electric Motor-1821

Electromagnetic rotation experiment of Faraday

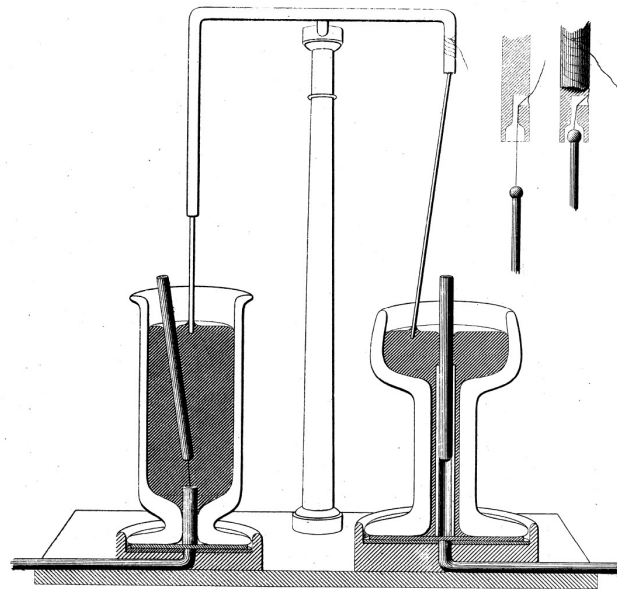
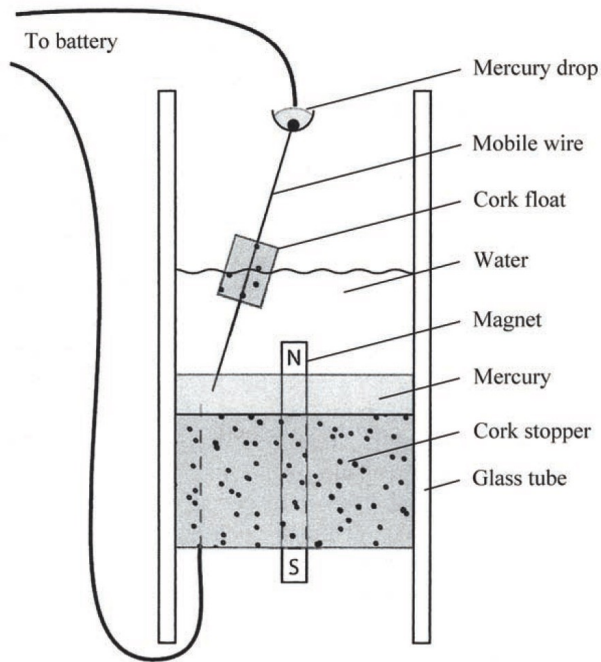

Wire fixed
Magnet free

Magnet fixed
Wire free

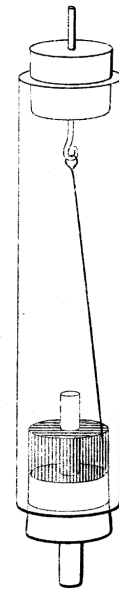

Gift model

Relative motion is important

Changing magnetic fields produced electric fields

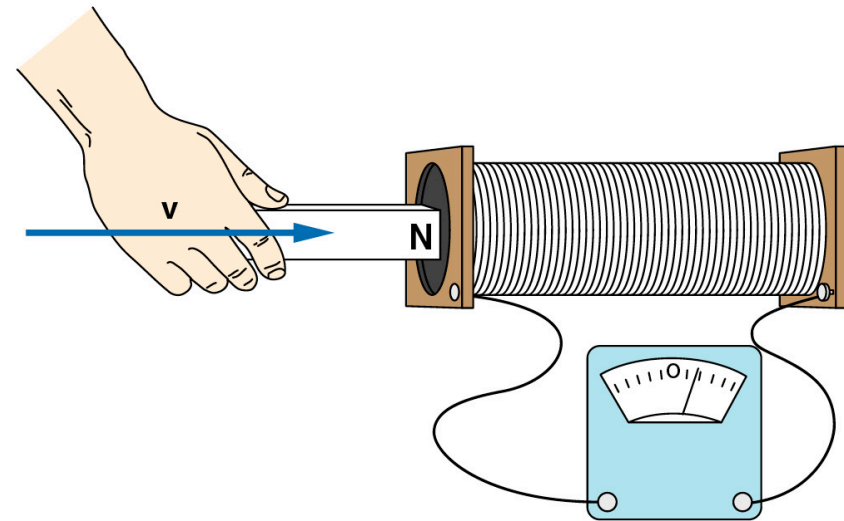
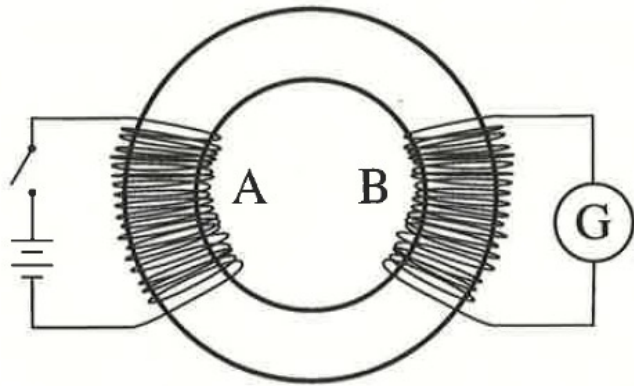

- A stationary magnet is a static phenomenon. Hence a stationary magnet cannot produce the converse of a steady current. If moving electricity produces magnetism, then moving magnetism will be necessary to produce electricity.
- It was Faraday's discovery that a changing magnetic force was needed.

Consequences of invention of electromagnetic induction

Electrical Generator, Dynamo, Transformer

Faraday's Demonstration That Changing Magnetism Produces Electricity

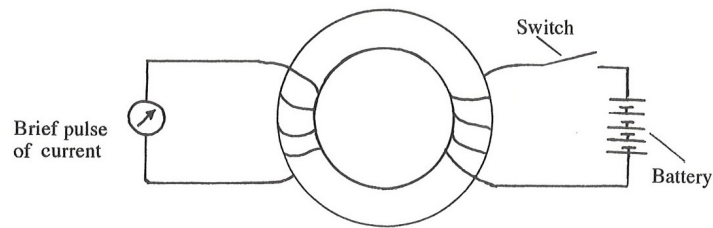

Faraday's Current Generation by a Moving Magnet

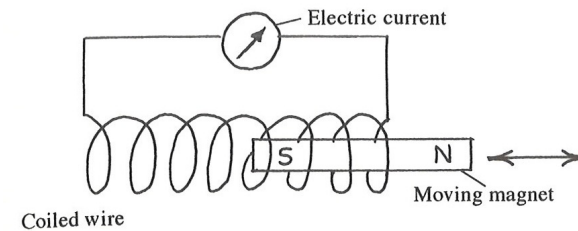

Faraday's Current Generator

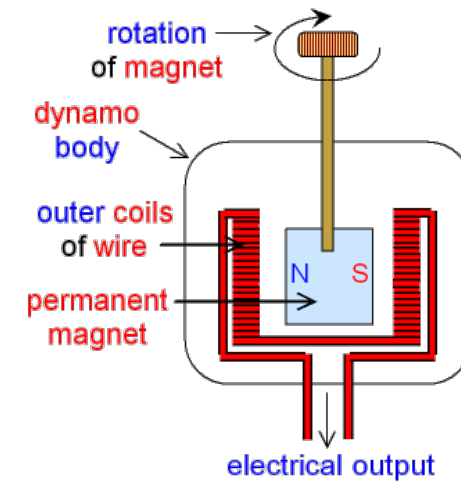
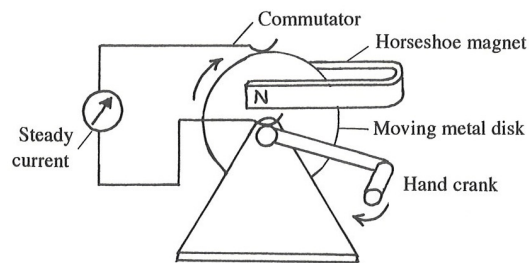

The basis of electricity and magnetism and do they communicate?

A struggle to conceptualize how forces could be transmitted across empty space.

Faraday's Lines of Forces

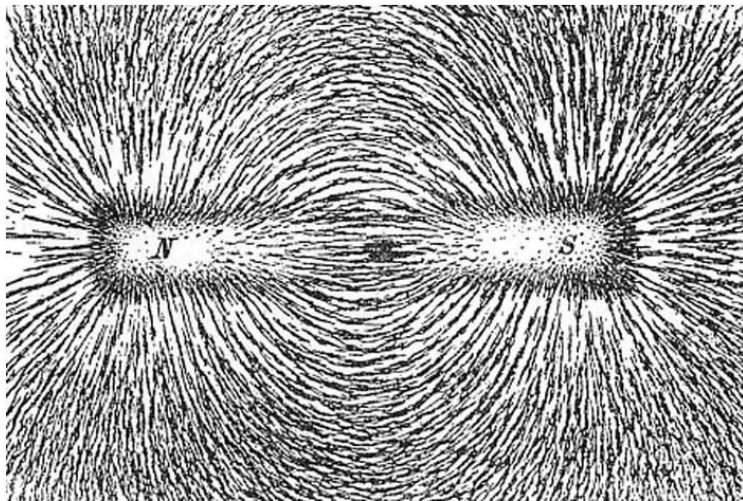

**Magnetic
lines of force**

If iron filings are sprinkled around a magnet, they form discrete curves, originating at the poles and extending into the space surrounding the magnet.

Faraday's view
Field

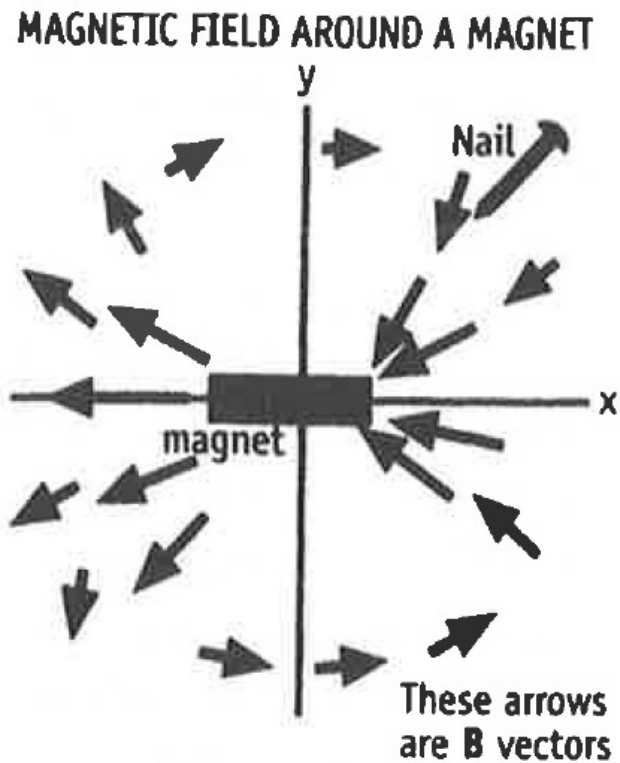

Newton's view
Action at a distance

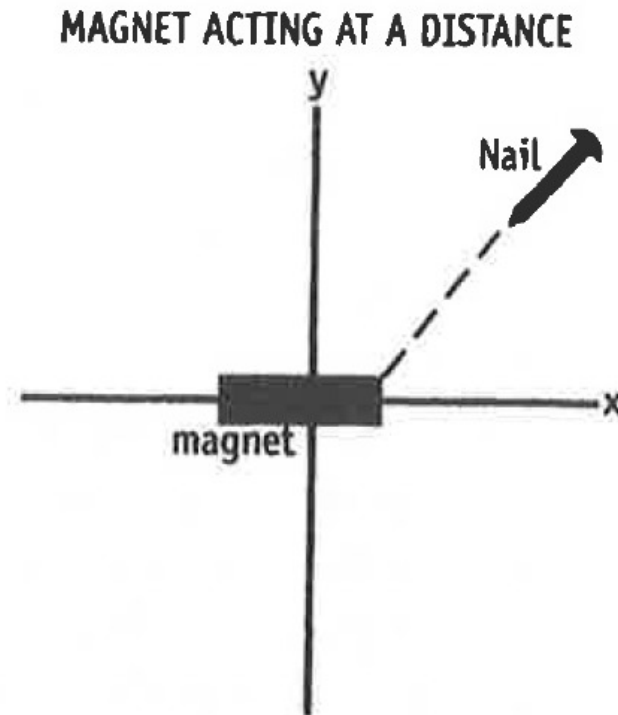

Magnetic and electrical lines of force are curved, not straight lines.

What is a field----does anyone know?

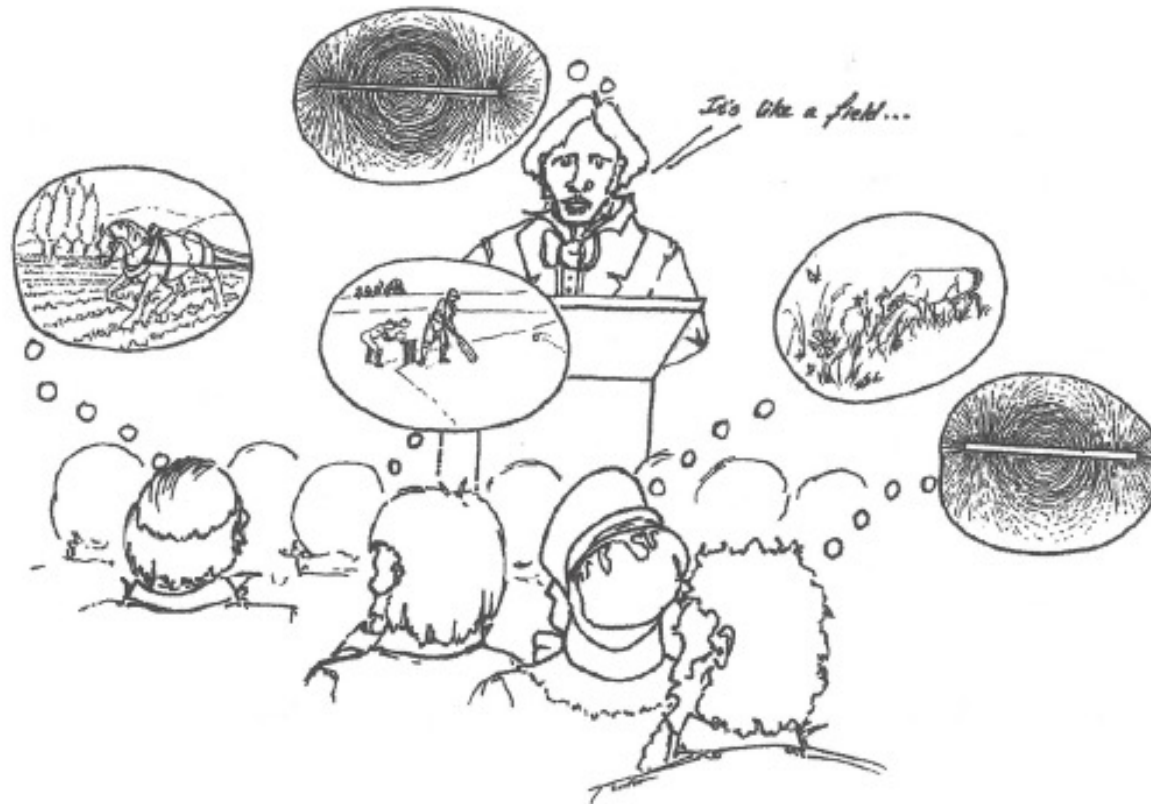

“How few understood the physical lines of force.”

Faraday to his niece, 1855

Interaction of magnetic field and light

In 1845, Thomson mathematically analyzed [Michael Faraday's](#) magnetic lines of force and wrote a letter to him in August of that year explaining how his calculations predicted that magnetic fields should affect the plane of polarized light.

Faraday had many years before experimented with light and magnetism, but without observing any connection between the two. Encouraged by Thomson's prediction, Faraday decided to readdress the problem and began a new series of experiments in his laboratory.

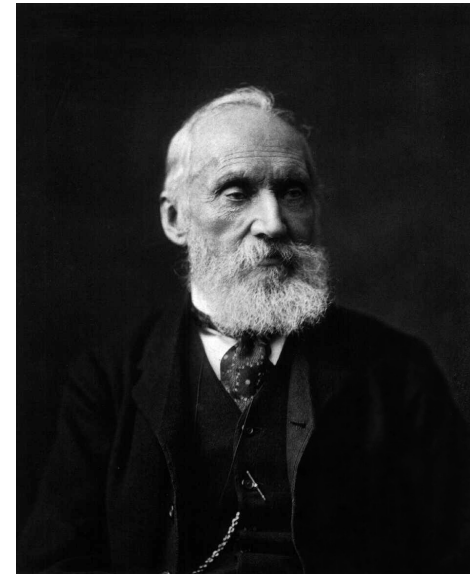

**William Thomson
(Lord Kelvin)
1824-1907**

Effect of Electricity and Magnetism on Light

Light is an electromagnetic wave

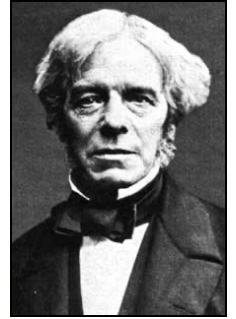

Michael Faraday
1791-1867

Faraday Effect: Magnetic field rotates plane polarized light

In 1845, [Michael Faraday](#) discovered that the plane of polarization of linearly polarized light is rotated when the light rays travel along the magnetic field direction in the presence of a transparent dielectric, an effect now known as Faraday rotation

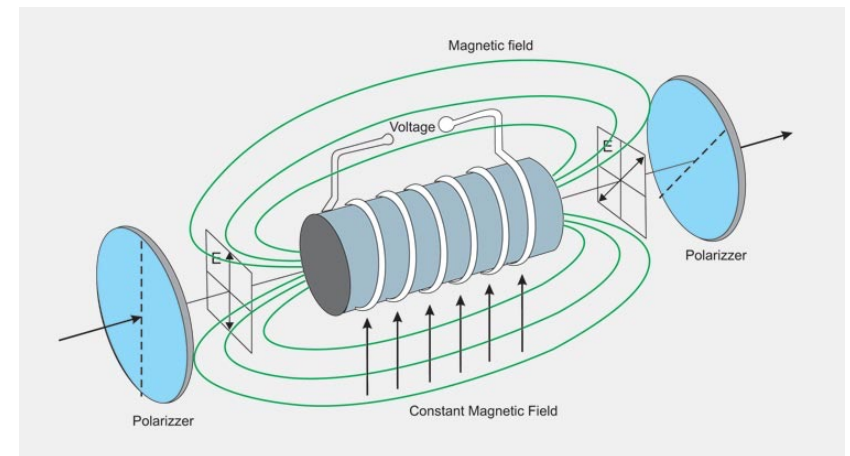
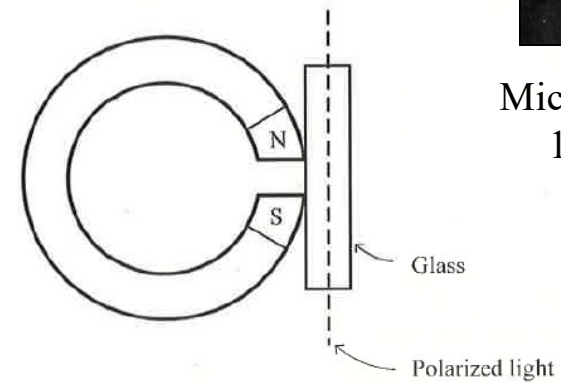



What is light?

A link between magnetism, electricity and light established

To Ampere, Nov 1845

“I happen to have discovered a direct relation between magnetism and light, also electricity and light---and the field it opens is so large & I think rich that I naturally wish to look at it first”

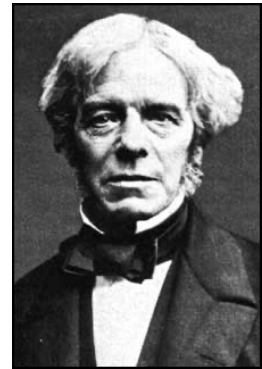

Michael Faraday
1791-1867

Claiming the precedence: Establishing for the first time a link between magnetism and light

In March 1832, Faraday asked the secretary of the Royal Society to deposit a note in his safe.

“I am inclined to compare the diffusion of magnetic forces from a magnetic pole to the vibrations upon the surface of disturbed water or those of air in the phenomenon of sound; *i.e.* I am inclined to think the vibratory theory will apply to these phenomena, as it does to **sound and, most probably, to **light**.”**

This proposal is very close to saying light propagates as waves not in straight lines. This idea is different from Newton’s theory of action at a distance. Light travels in straight lines.

Lines of force

Faraday

Faraday rejected several long-held Newtonian assumptions.

- dismissed action at a distance.
- scrapped the need for the ether.

Faraday lacked the classical education of his colleagues, his theories forged a new path away from traditional Newtonian force relations. He moved away from traditional scientific thought of his day

Biot

If you look for exact knowledge in his theories you will be disappointed- flashes of wonderful insight you meet here and there, but he has no exact knowledge himself, ----

Airy

Faraday should brush up on his mathematics and leave theoretical physics to the properly trained.

James Clerk Maxwell

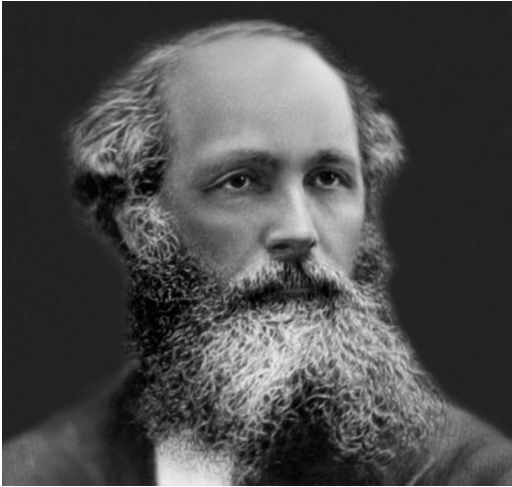

James Clerk Maxwell
(1831-1879)

The Man who Changed Everything: The Life of James Clerk Maxwell, Basil Mahon, 2003

Faraday, Maxwell, and the Electromagnetic Field: How Two Men Revolutionized Physics, N. Forbes and B. Mahon, 2014.

Men of Science, J. G. Crowther, 1936, Ch. 5.

Einstein's Heroes: Imagining the World through the Language of Mathematics, R. Arianrhod, 2005

“One scientific epoch ended and another began with James Clerk Maxwell”

A. Einstein

“From a long view of the history of mankind seen from, say, ten thousand years from now there can be little doubt that the most significant event of the nineteenth century will be judged as Maxwell’s discovery of the laws of electrodynamics.”

R. Feynmann

Knowns and unknowns about light before Maxwell

Knowns

- Light responds to electricity and magnetism (Faraday rotation)
- Light is a mixture of various visible and invisible radiations (visible, UV and IR radiations)
- Light travels like a wave (double slit expt); particle idea dropped
- Electric field generated between two metal plates and magnetic field generated by magnets are independent of each other.
- Electricity and magnetism creates fields and don't follow the Newtonian principle of 'action at a distance' (Faraday)

Unknowns

- The speed of light
- Connection between electric and magnetic fields
- Connection between electric and magnetic fields and light
- Likely existence of other rays of light in addition to visible, UV and IR



James Clerk Maxwell
(1831-1879)

- In 1861, Maxwell extended Faraday's proposal by mathematically deriving that changing electric fields produced magnetic fields and in fact the two phenomena should be perceived as a single entity.
- This means oscillating electric fields would produce magnetic fields. Oscillating magnetic fields would produce electric fields.
- A moving electric charge would thus produce a magnetic field.

Maxwell's Equations of Electromagnetism

Gauss' Law for Electrostatics

$$\oint \vec{E} \cdot d\vec{A} = q/\epsilon_0$$

Gauss' Law for Magnetism

$$\oint \vec{B} \cdot d\vec{A} = 0$$

Faraday's Law of Induction

$$\oint \vec{E} \cdot d\vec{s} = - \frac{d\Phi_B}{dt}$$

Ampere's Law

$$\oint \vec{B} \cdot d\vec{s} = \mu_0 \epsilon_0 \frac{d\Phi_E}{dt} + \mu_0 i$$

Maxwell explained electric and Magnetic fields in mathematical equations

- Electric charges produce electric fields (Coulomb's Law)
- Electric currents (moving charges) produce magnetic fields (Ampere's Law)
- An electromagnetic wave is a combination of electric and magnetic fields that vibrate together in space and time in a synchronous fashion and propagate at the speed of light
- Maxwell's equations showed that electricity and magnetism are two sides of the same coin, and that light is that coin in movement.

The generation of an electromagnetic wave

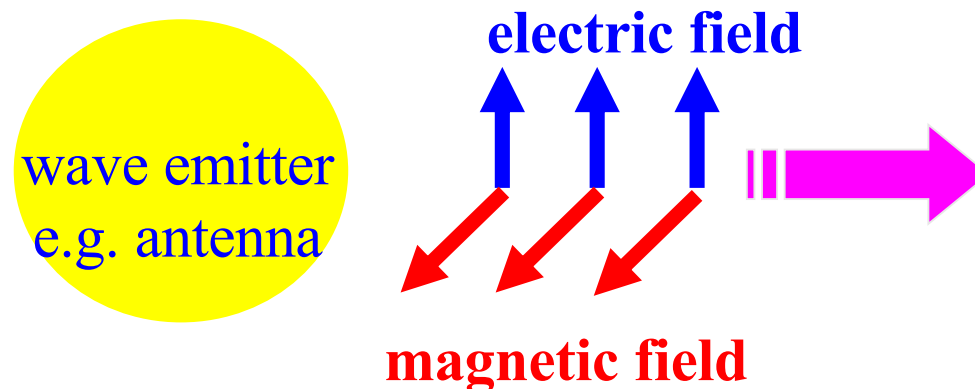

- The electromagnetic wave is a *transverse wave*, the **electric** and **magnetic** fields oscillate in the direction perpendicular to the direction of propagation
- The time varying **electric field** generated the time varying **magnetic field** which generates the time varying electric field and so on and so on
- The electric and the magnetic part stimulate each other producing a cycle.

Maxwell predicts the speed of light

Where the speed of light “c” is given through constants from both electricity and magnetism.

$$c = 1/\sqrt{\epsilon_0 \mu_0}$$
$$= 3 \times 10^8 \text{ m/s}$$

James Clerk Maxwell

Light is a traveling electromagnetic wave (1862)

- ▶ Unified electromagnetism and light.
- ▶ Explained the existence of invisible forms of light.
- ▶ Electromagnetic waves propagate in free space at $c = 3 \times 10^8$ m/s.
- ▶ E and B are always perpendicular to each other, and perpendicular to the direction of propagation.
- ▶ Based on the double slit experiments of Thomas Young and the equations of Maxwell, by 1900 most scientists believed that light behaved as a wave.

Maxwell: Light is an electromagnetic wave

Faraday to Ampere, Nov 1845

“I happen to have discovered a direct relation between magnetism and light, also electricity and light---and the field it opens is so large & I think rich that I naturally wish to look at it first”

Maxwell to Faraday, October 1861

"I think we have now strong reason to believe, whether my theory is a fact or not, that the luminiferous and the electro-magnetic medium are one. In other words, light is indeed an electromagnetic undulation-a *ray-vibration*, as you had called it in 1846."

Maxwell Publication in 1865

“The electromagnetic theory of light, as proposed by Faraday, is the same in substance as that which I have begun to develop in this paper, except that in 1846 there were no data to calculate the velocity of propagation.”

<https://www.youtube.com/watch?v=WqefMRAXt2k>

Summary: The Laws of Electricity and Magnetism

- Laws of electricity

- Electric charges produce *electric* fields (Coulomb)
- Electric fields begin and end on charges

- Laws of magnetism

- Currents produce *magnetic* fields (Ampere)
- Magnetic field lines are closed loops
- A changing magnetic field can produce a current (*induced currents*) (Faraday)
- A changing electric field can produce a magnetic field (Maxwell)

Heinrich Rudolf Hertz

- 1857 – 1894 (lived for 37 yrs)
- German physicist
- First to generate and detect electromagnetic waves in a laboratory setting in 1887.
- As predicted by Maxwell he established the existence of **radiowaves**.
- Established the phenomenon of photoelectric effect



Hertz
1857-1894

Accidental Discovery

In 1888, in a corner of his physics classroom at the Karlsruhe Polytechnic in Berlin, Hertz generated electric waves using an electric circuit; the circuit contained a metal rod that had a small gap at its midpoint, and when sparks crossed this gap violent oscillations of high frequency were set up in the rod. Hertz proved that these waves were transmitted through air by detecting them with another similar circuit some distance away. He also showed that like light waves they were reflected and refracted and, most important, that they traveled at the same speed as light but had a much longer wavelength. These waves, originally called Hertzian waves but now known as radio waves, conclusively confirmed Maxwell's prediction on the existence of electromagnetic waves, both in the form of light and radio waves.

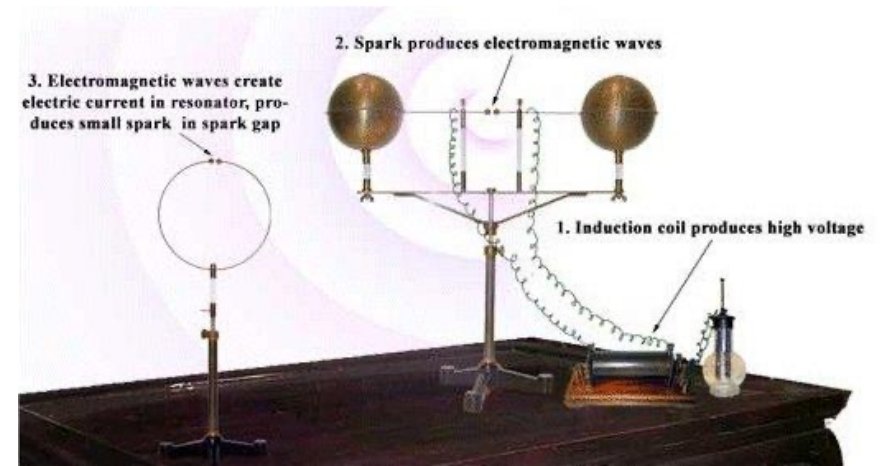

A great number of modern developments, like radio, television and Wi-Fi were spun out of Hertz's simple demonstrations.

Experimental support for light as wave

The transmitter consists of two spherical electrodes connected to an induction coil, which provides short voltage surges to the spheres, setting up oscillations in the discharge between the electrodes.

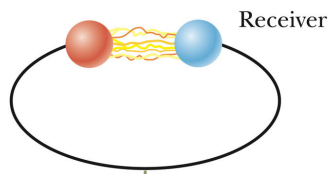
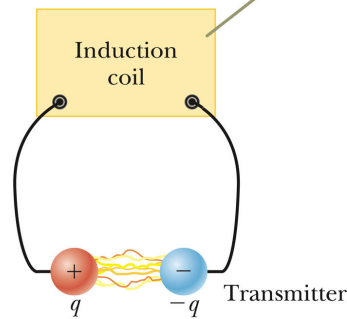

The receiver is a nearby loop of wire containing a second spark gap.

Hertz accidentally discovered in 1888

- Sparks were induced across the gap of the receiving electrodes when the frequency of the receiver was adjusted to match that of the transmitter.
- Hertz thought that if Maxwell was right, this would radiate electromagnetic waves through air. In a series of other experiments, Hertz also showed that the radiation generated by this equipment exhibited wave properties.
- Interference, diffraction, reflection, refraction and polarization
- He also measured the speed of the radiation.
- It was close to the known value of the speed of light.

"I do not think that the wireless waves I have discovered will have any practical application."

Light is indeed electromagnetic waves

- Hans Christian Oersted finds that an electric current deflects a compass needle. (1820)
- Andre Marie Ampère finds that parallel wires carrying current produce forces on each other. (1820)
- Faraday laid the groundwork with his discovery of electromagnetic induction. (1846)
- Maxwell explained theoretically that light is an electromagnetic wave (1865)
- Heinrich Hertz showed experimentally that EM waves exist travels at the speed predicted by Maxwell. (1887)

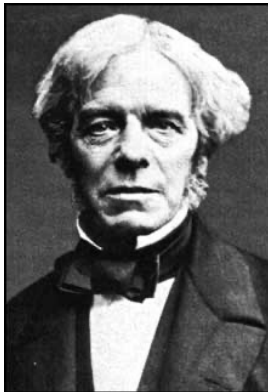

Michael Faraday
1791-1867



James Clerk Maxwell
1831-1879



Heinrich Rudolf Hertz
1857-1894

Over and Beyond the Rainbow

Visible rays (1665)



Isaac Newton

Infrared (1800)



F. W. Herschel
1738-1822

Ultraviolet (1801)



J. W. Ritter
1776-1810



H. R. Hertz
(1857-1894)

Radiowaves (1886)

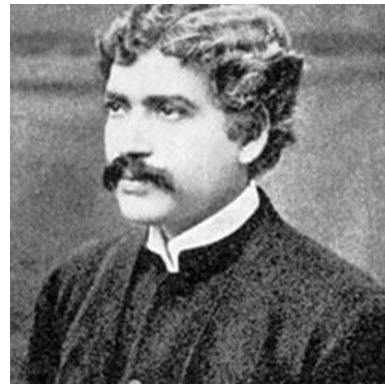

J. C. Bose
(1858 - 1937)

Microwaves (1894)



W. C. Röntgen
(1845 - 1923)

X-Rays (1895)



Paul Villard
(1860 - 1934)

γ -Rays (1900)

The Wave Nature of Light

- The amplitude is the wave's height from the origin to a crest.

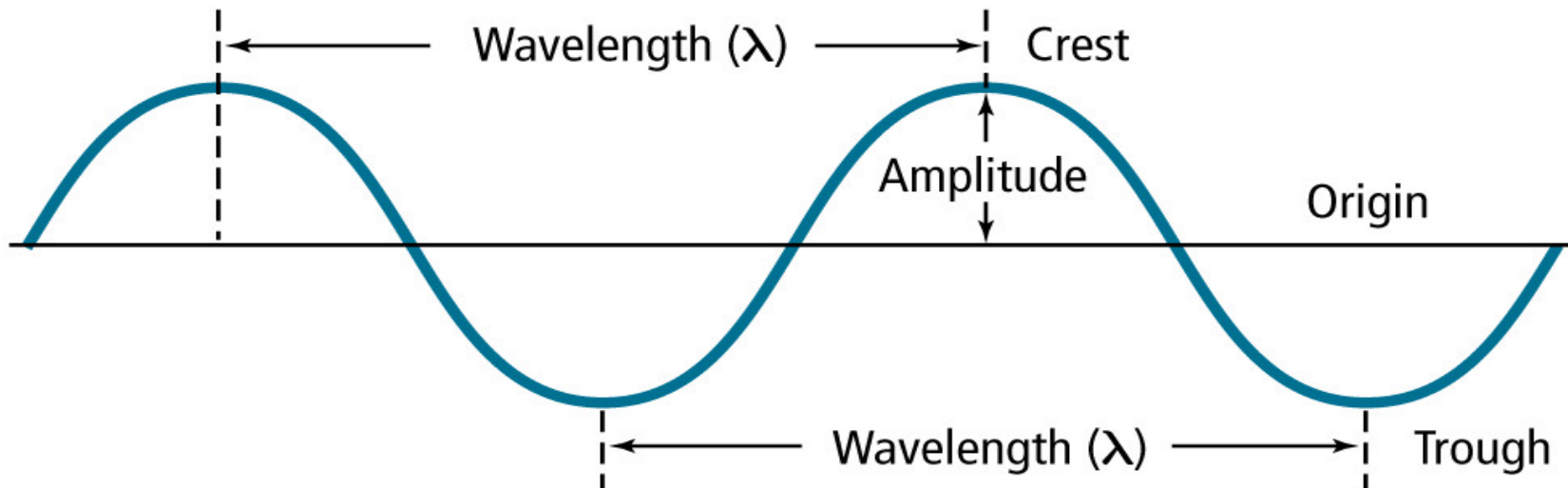

The Wave Nature of Light

- The frequency (ν) is the number of waves that pass a given point per second.
- Wavelength and frequency are inversely related—the shorter the wavelength, the higher the frequency.
- Light is a type of energy that travels through space at a constant speed of 3.0×10^8 m/s (186,000 mi/s).
- Classical: Energy carried by a light wave is proportional to the *Amplitude* of wave. $E \propto A^2$

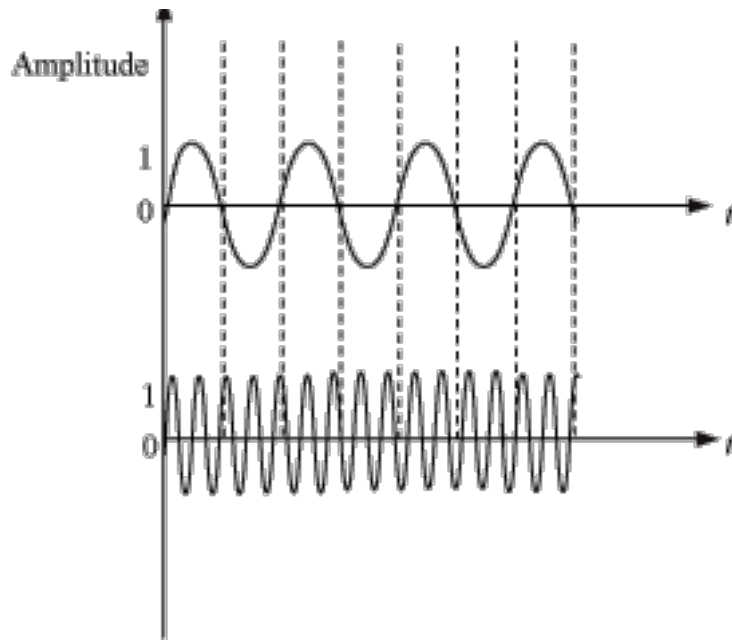

Amplitude and Wavelength

Different wavelengths,
different colors

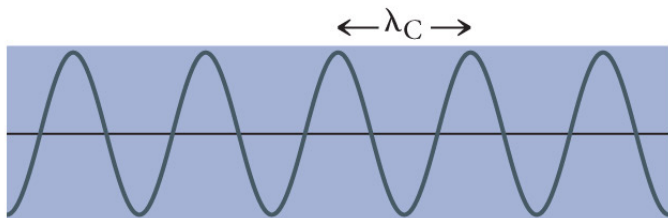
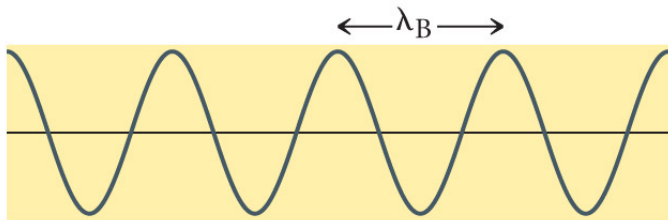
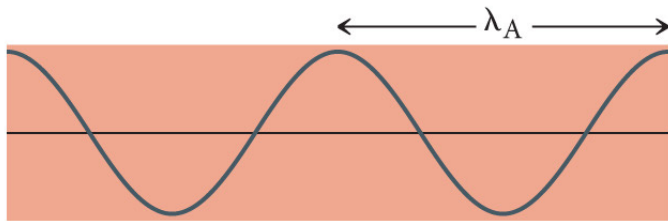

Different amplitudes,
different brightness

dim



bright

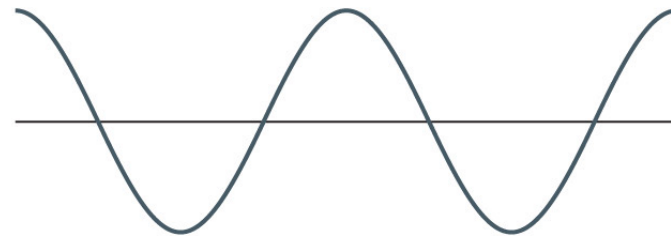

Uses of electromagnetic radiations of different wavelengths

$$\lambda = c/\nu$$

$$\nu = c/\lambda$$

Types of Electromagnetic Radiation

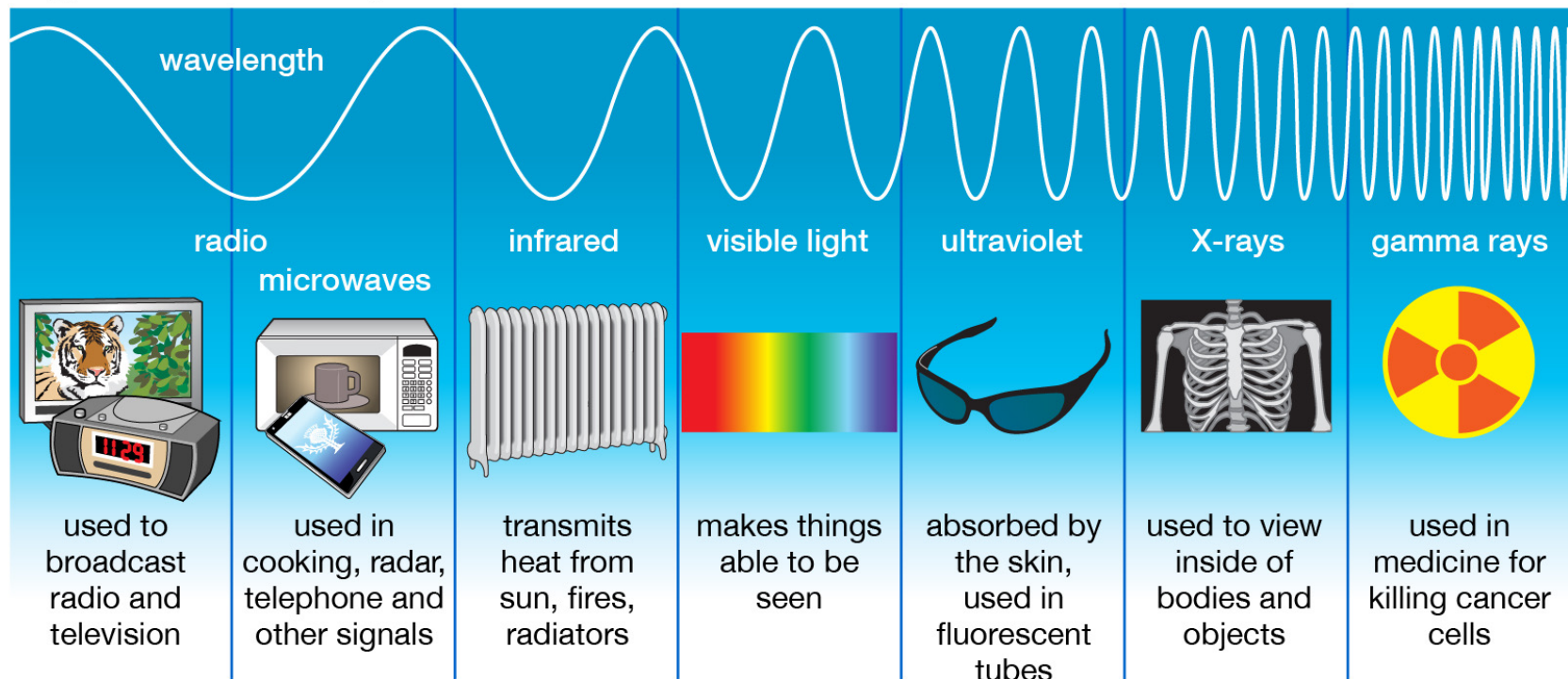

How does light wave travel?

- Ocean waves water molecules
- Sound molecules in air
- Light **plenum** later **aether**

René Descartes 1596 –1650

Believed that an invisible substance, called the plenum, permeated the universe. Light is a disturbance that traveled through the plenum.

Robert Boyle

Christiaan Huygens

J. C. Maxwell

H. Hertz

H. Lorentz

Plenum was changed to **aether** and

Thought to be the medium through which light propagates. The universe is filled with a fluid called aether. This idea was supported by numerous scientists

End of aether came due to **Albert Einstein's theory of relativity (1905)**

Speed of Energy Transmission



Heat is Light



Figure 1: Campfires emit radiant "energy" in the visible and infrared spectrum, which upon interaction with your skin is felt as "radiant heat".^[1]

Hot solid bodies give out radiation

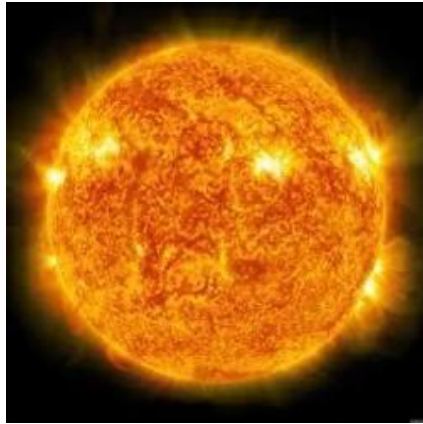

Sun



©The McGraw-Hill Companies, Inc./Charles Winters Photographer

Electric heating element



Cook-out grill



© Feng Yu/Shutterstock.com

Light bulb filament

Temperature and color distribution of galaxy

Color of the star is related to surface temperature

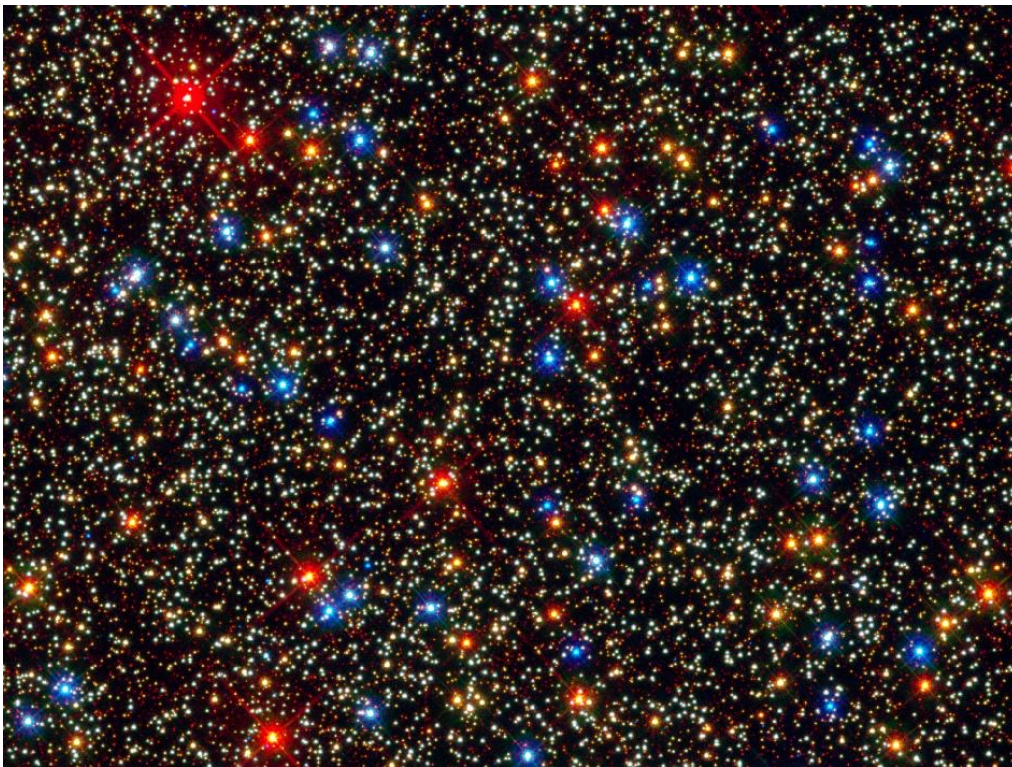

Constellation of Orion

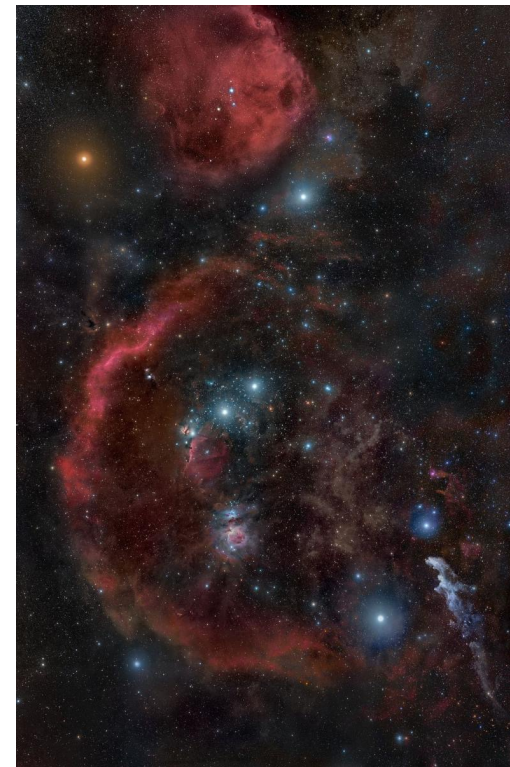

Why are the planets in our solar system so different in colors?



Stellar classification: Color and temperature are related

Class	Effective temperature ^{[3][4]}	Vega-relative chromaticity ^[5] [6][a]
O	≥ 30,000 K	blue
B	10,000–30,000 K	bluish white
A	7,500–10,000 K	white
F	6,000–7,500 K	yellowish white
G	5,200–6,000 K	yellow
K	3,700–5,200 K	light orange
M	2,400–3,700 K	orangish red

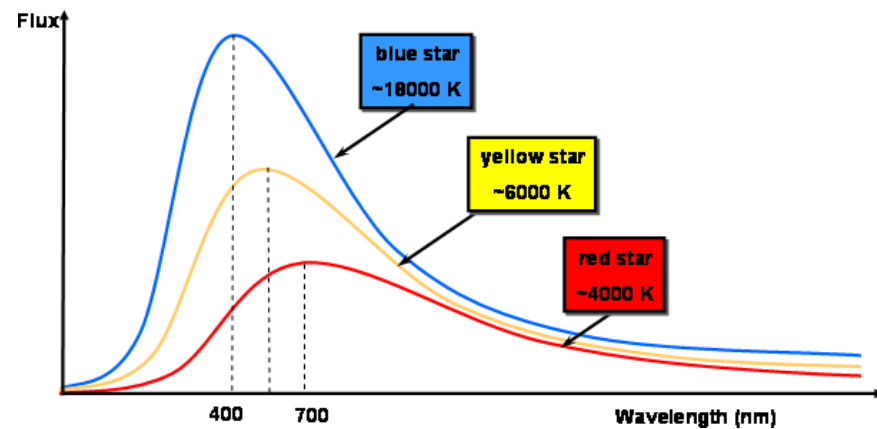

"Oh, Be A Fine Guy/Girl: Kiss Me!"

The Glass Universe
Dava Sobel, 2016 (book)

What is heat and how is it related to light?

What is the source of the light upon heating and what is the relationship between the frequency of the radiation (i.e., the color of the light) and the temperature of the body?

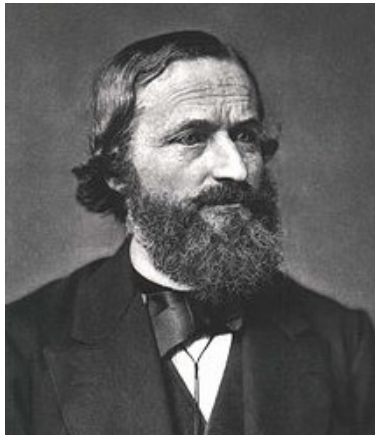

Gustav Robert Kirchhoff
1824–1887

A solid object emits visible light when it is heated to about 1000 K and above (Kirchhoff, 1860)

The *color* (and the intensity) of the light depend only on the temperature and not on the identity of the substance.

For an arbitrary body, the ratio between the emissive spectral radiance, E , and the dimensionless absorptive ratio, A , can be anywhere between 0 and 1.

Blackbody Radiation

An object at any temperature is known to emit thermal radiation.

The electromagnetic radiation emitted by a heated object

Characteristics depend on the temperature and surface properties.

The thermal radiation consists of a continuous distribution of wavelengths from all portions of the electromagnetic spectrum.

A **black body** is an ideal system that absorbs all radiation incident on it.

“A good absorber is a good emitter” (Kirchhoff)

A material with emission/absorption (E/A) as one is called ‘Black Body’.

An example of such a thing would be an enclosed cavity, the internal surface of which continuously emits and absorbs radiation of all frequencies.

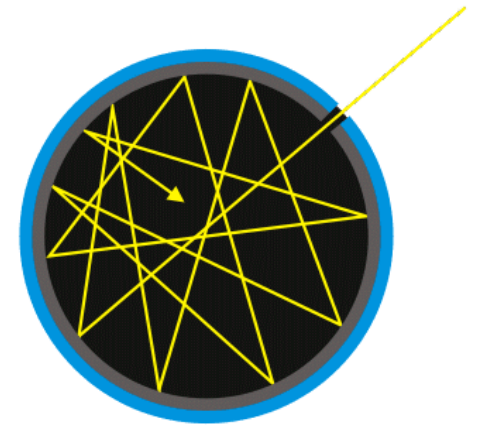

Conceptual Black Body

Black body is a hypothetical perfect radiator that absorbs all incident light and, therefore, emits all of that light when maintained at a constant temperature in order to preserve equilibrium.

Apparatus of Lummer and Kurlbaum to measure the spectrum of black-body radiation. An electrical current heats the filament E located in a tube inside the cylinder C to a fixed temperature T, giving rise to black-body radiation inside this cylinder. The spectrum of this radiation is observed by some radiation exiting through the hole at one end along the axis of the cylinder.

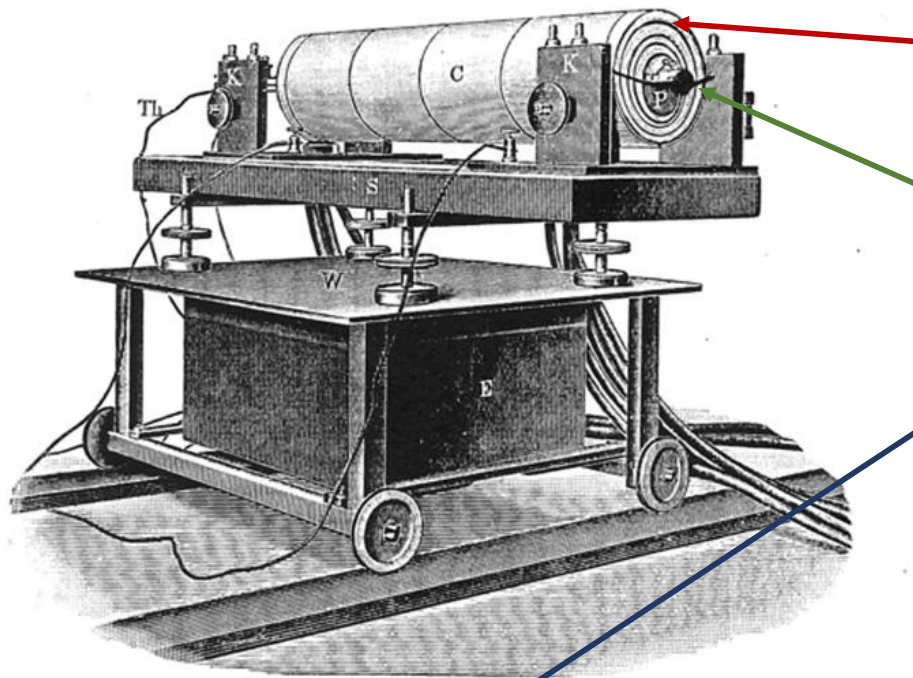

Schwarzer Körper nach Lummer-Kurlbaum.



Strahlungsrohr.

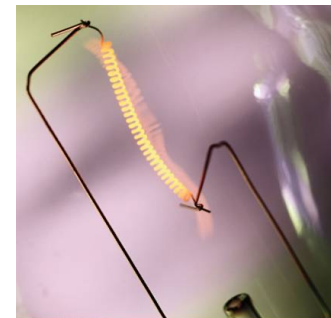

© 2004 Thomson Brooks/Cole

The first UV-Vis absorption spectrometer

The Bunsen-Kirchhoff Spectroscope with Bunsen Burner (1859)

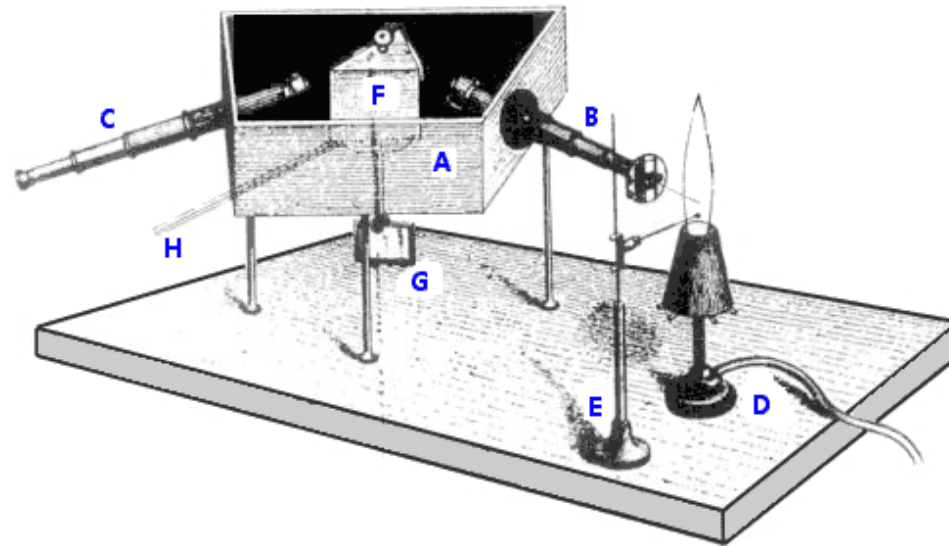

A) Box, colored black on the inside; (B) & (C) Telescopes; (D) Bunsen Burner; (E) Sample Holder; (F) Prism; (G) Mirror; (H) Handle to rotate prism and mirror.

Black-Body Spectrum at different temperatures

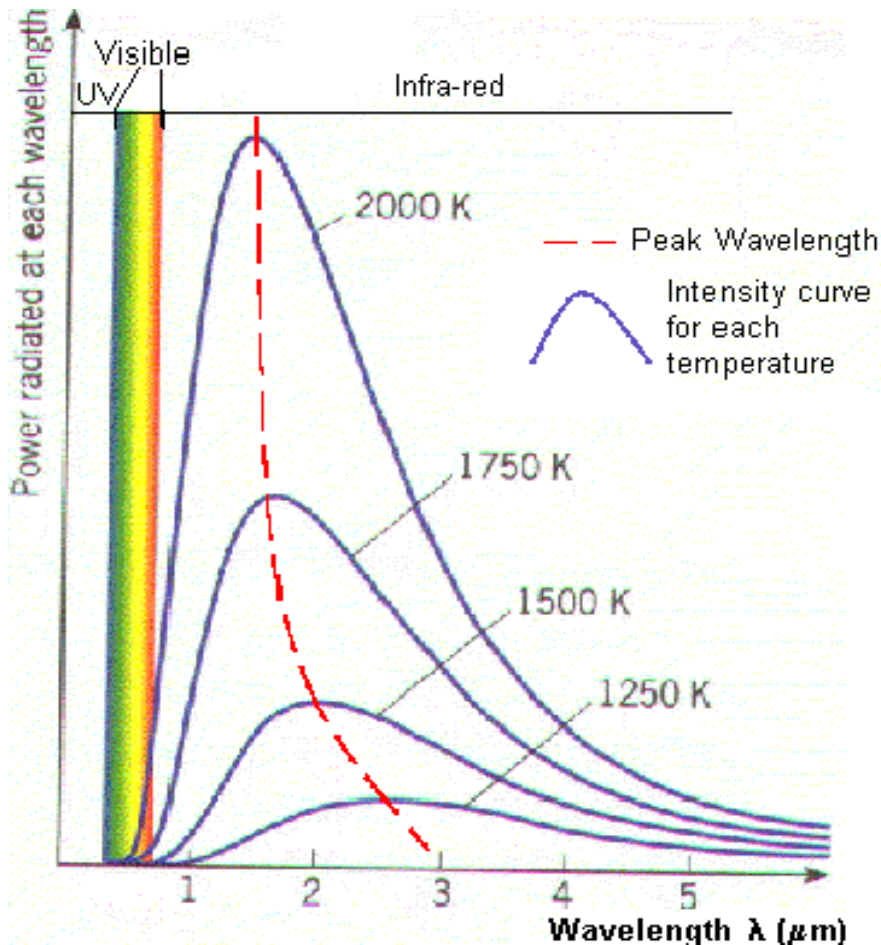

Robert Kirchhoff, 1860

The spectrum (wavelength and intensity) depend on the temperature

The hotter the black body, the shorter the peak wavelength.

A black body emits all wavelengths of light but not equally; there is always a wavelength in which the radiation peaks.

The peak height increases and shifts to shorter wavelengths as the temperature of the black body increases.

The Stefan-Boltzmann Law

Connects temperature to the amount of energy released

$$E = \sigma T^4$$

where σ is a constant

(the Stefan-Boltzmann constant) which has a value of

$$5.67 \times 10^{-8} \text{ W} \cdot \text{m}^{-2} \cdot \text{K}^{-4}$$

and T is the absolute temperature (in Kelvin)

This law links the total amount of energy flux that is emitted by a blackbody to the body's temperature (*actually, the 4th power of the body's absolute temperature*)

Wien's Law

Connects temperature to the maximum of emission wavelength

$$\lambda_m = a/T$$

where λ_m is the WAVELENGTH in the spectrum at which the energy peak occurs

T is the absolute TEMPERATURE of the body, and

a is a constant (with a value of 2898) (if λ_m is expressed in micrometers.)

The hotter the body, the shorter the wavelength

The cooler the body, the longer the wavelength

Wien displacement law, useful for instance in determining the temperature of the sun and stars. As per the equation the Sun's temperature is calculated to be 5700 K. The discovery was awarded Physics Nobel Prize in 1911.

Color reveals the temperature
of the surface

$$\text{Wein's Law: } \lambda_{\text{peak}} = \frac{b}{T}$$

Mars is too COLD!!

Venus is too HOT!

Earth is JUST RIGHT!

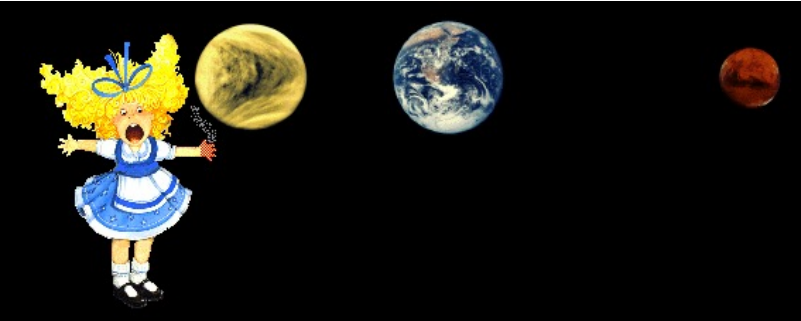

Another attempt to fit the spectrum

The classical theory (red-brown curve) shows intensity growing without bound for short wavelengths, unlike the experimental data (blue curve).

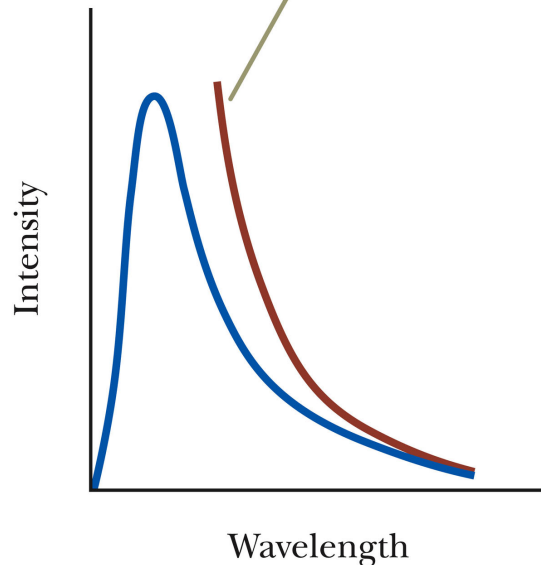

The Lord Rayleigh
Nobel Prize 1904

Rayleigh-Jeans law

$$B_{\lambda}(T) = \frac{2ck_{\text{B}}T}{\lambda^4}$$

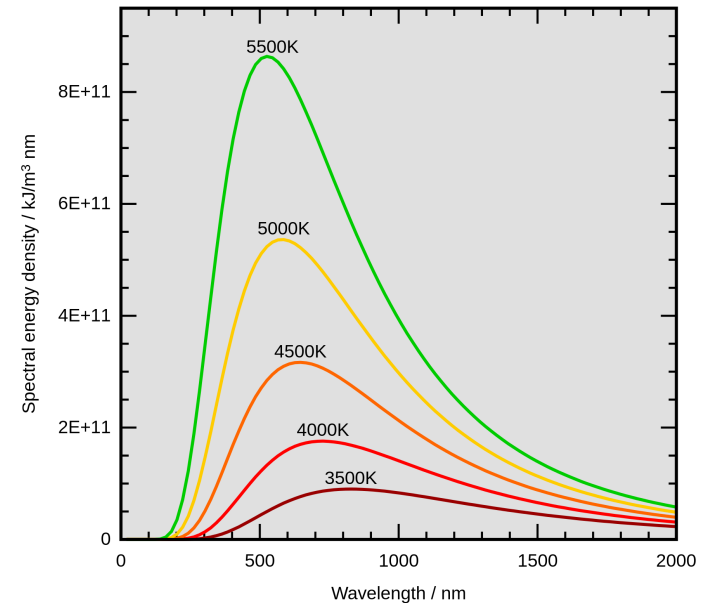

The theory did match experimental data for longer wavelengths but failed for shorter ones. This is known as the “ultraviolet catastrophe,” a name given by Paul Ehrenfest in 1911.

Where is the problem?

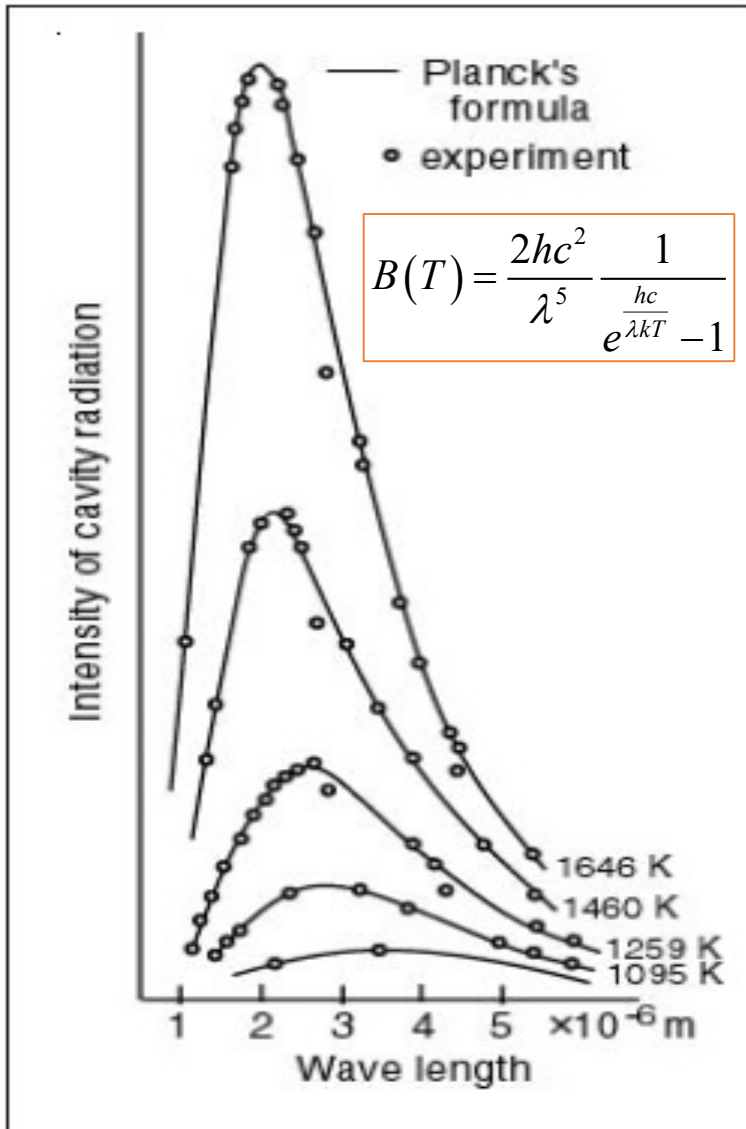

Wien formula fits the shorter wavelength but fails the longer wavelength side of the spectrum.

Rayleigh-Jeans formula fits the longer wavelength but fails miserably at shorter wavelength but fits at longer wavelength

Both formulae were developed using **classical physics principle—equipartition of energy** ($1/2kT$).

What is absorbing and emitting?

Why the spectrum has a maximum, i.e., with increasing temperature why the intensity does not keep increasing as predicted by Rayleigh-Jeans ?

Equipartition Theorem (Classical Physics)

“The total energy contained in the assembly of a large number of individual particles exchanging energy among themselves through mutual collisions is shared equally (on the average) by all the particles.”

Motion

Clausius and other physicists of 1800s had imagined **all the atoms in a gas moving at the same speed**. They knew this wasn't true, that in fact atoms would move with a range of speeds, but they didn't have the mathematical sophistication to tackle the full problem.

Energy

The theorem of equipartition of energy states that molecules **in thermal equilibrium have the same average energy** associated with each independent degree of freedom of their motion.

Every particle has a translational energy of $KE_{avg} = \frac{3}{2}kT$

Planck's Theory of Blackbody Radiation

- In 1900 Max Planck developed a theory of blackbody radiation that leads to an equation that correctly predicted the intensity and wavelength of the radiation with temperature.
- To achieve this, he moved away from well established principles of classical physics, equipartition theorem.
- For the first time he analyzed the data based on probabilities (modern statistical physics) that was not a well accepted concept at that time.

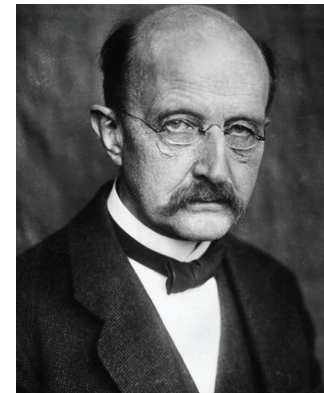
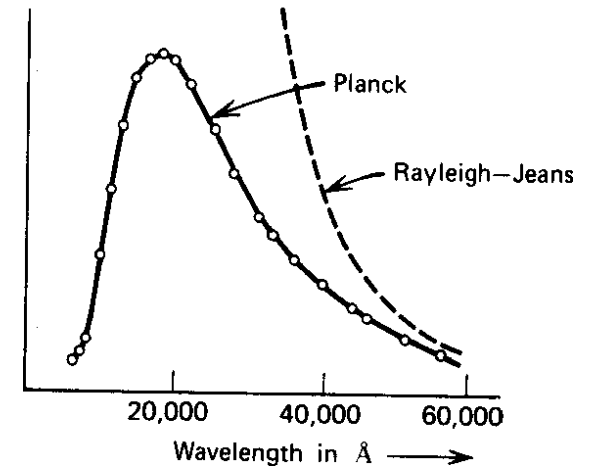

Max Planck

Maxwell-Boltzmann Distribution

Statistic/Probabilistic Approach

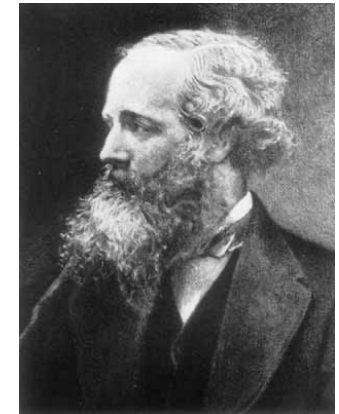
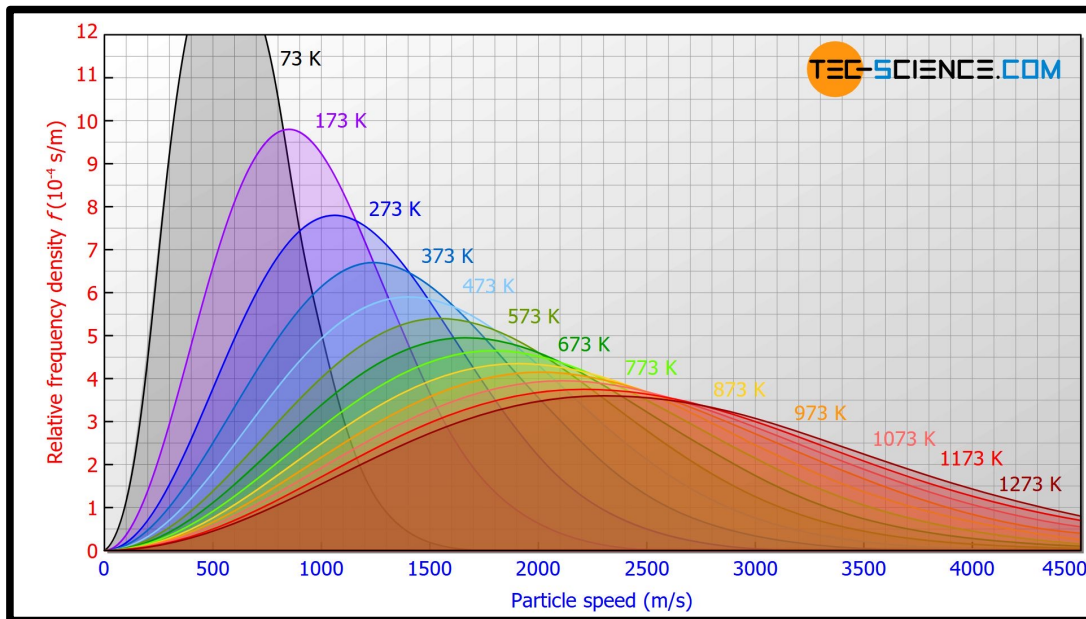

James Clerk Maxwell
(1831-1879)



L. Boltzmann
(1844-1906)

“The true Logic for this world is the Probabilities. ... This branch of Math., which is generally thought to favor gambling, dicing, and wagering, and therefore highly immoral, is the only ‘Mathematics for Practical Men,’ as we ought to be.” *Maxwell, 1850*

Planck noticed the similarity

Temperature dependence of velocity of molecules: Maxwell-Boltzmann distribution

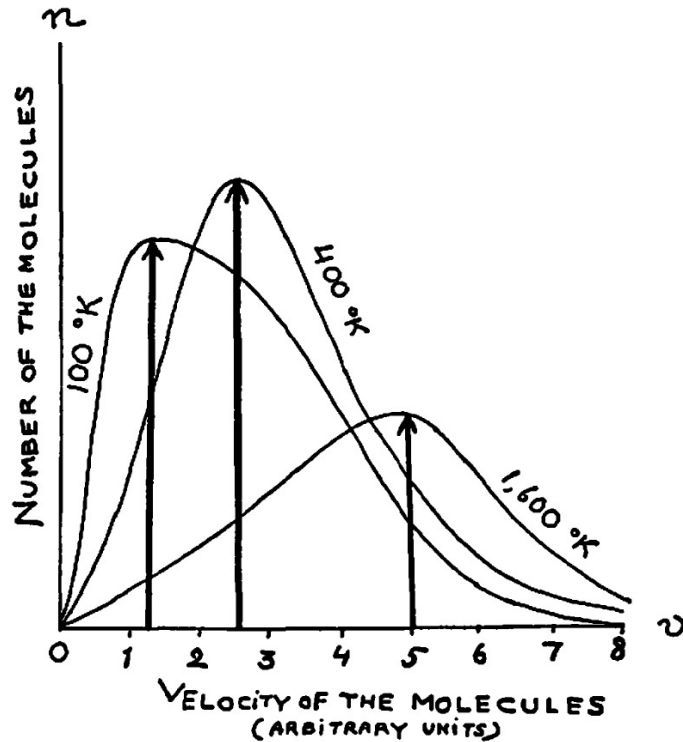

Fig. 1. Maxwell's distribution: the number of molecules having different velocities v is plotted against the velocities for three different temperatures, 100° , 400° , and 1600°K . Since the number of molecules in the container remains constant, the areas under the three curves are the same. The average velocities of the molecules increase proportionally to the square root of the absolute temperature.

Temperature dependence of wavelength of emitted light: Blackbody radiation

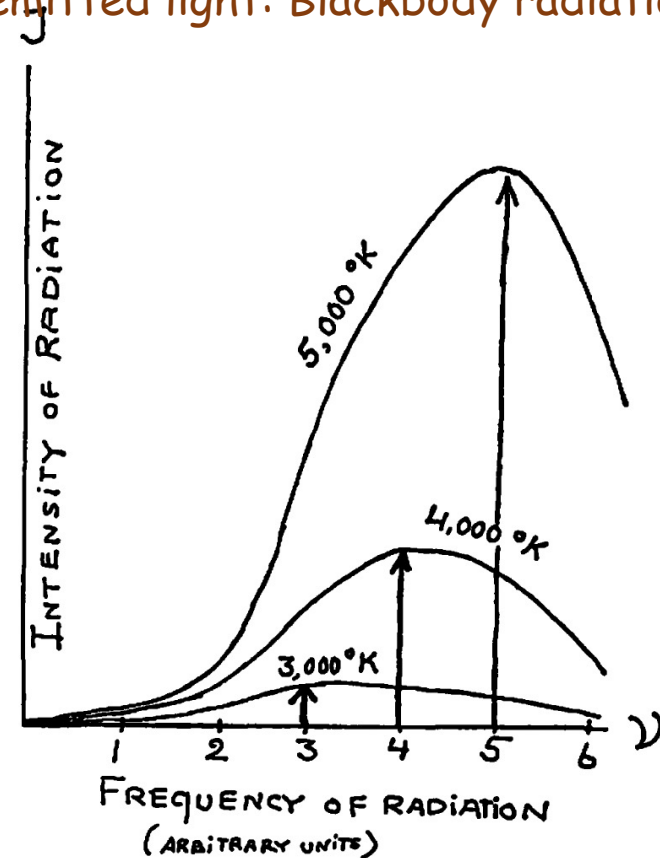

Fig. 2. The observed distribution of radiation intensities for different frequencies ν is plotted against the frequencies. Since the radiation energy content per unit volume increases as the fourth power of the absolute temperature T , the areas under the curves increase. The frequency corresponding to maximum intensity increases proportionally to the absolute temperature.

Maxwell-Boltzmann Distribution

<https://www.khanacademy.org/science/physics/thermodynamics/temp-kinetic-theory-ideal-gas-law/v/maxwell-boltzmann-distribution>

Video

<https://www.khanacademy.org/science/physics/thermodynamics/temp-kinetic-theory-ideal-gas-law/a/what-is-the-maxwell-boltzmann-distribution>

Text

Planck's Radiation Law

$$B(T) = \frac{2hc^2}{\lambda^5} \frac{1}{e^{\frac{hc}{\lambda kT}} - 1}$$

- B = Spectral density of electromagnetic radiation emitted by a black body; the cgs unit $\text{erg} \cdot \text{s}^{-1} \cdot \text{sr}^{-1} \cdot \text{cm}^{-2} \cdot \text{Hz}^{-1}$.
- h = Planck's constant = 6.63×10^{-34} Joule - seconds
- k = Boltzmann's constant = 1.38×10^{-23} Joule -K⁻¹
- c = velocity of light = $3 \times 10^{+8}$ meter - seconds⁻¹
- T = temperature [K]
- λ = wavelength [meters]

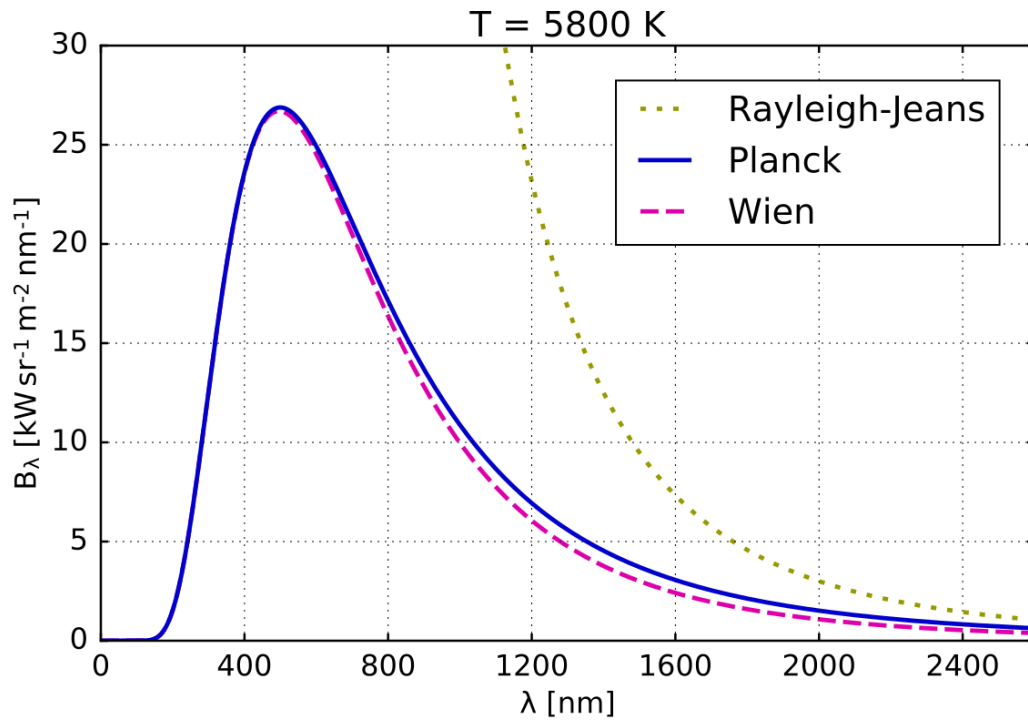

Comparison of Rayleigh–Jeans law with Wien approximation and Planck's law, for a body of 5800 K temperature.

Stefan–Boltzmann law $E = \sigma T^4$

Wien's Law $\lambda_{\text{peak}} = \{hc/(4.965 k)\}/T$

Rayleigh-Jeans law $B_{\lambda}(T) = \frac{2ck_{\text{B}}T}{\lambda^4}$

Planck's eqn $B(T) = \frac{2hc^2}{\lambda^5} \frac{1}{e^{\frac{hc}{\lambda kT}} - 1}$

Comparison between Planck's law of BB radiation and Rayleigh-Jean's law

- Planck's equation is in complete agreement with experimental observations.
- He assumed the cavity radiation came from atomic oscillations in the cavity walls.
- Planck made several assumptions (at that time unfounded) about the nature of the oscillators in the cavity walls.

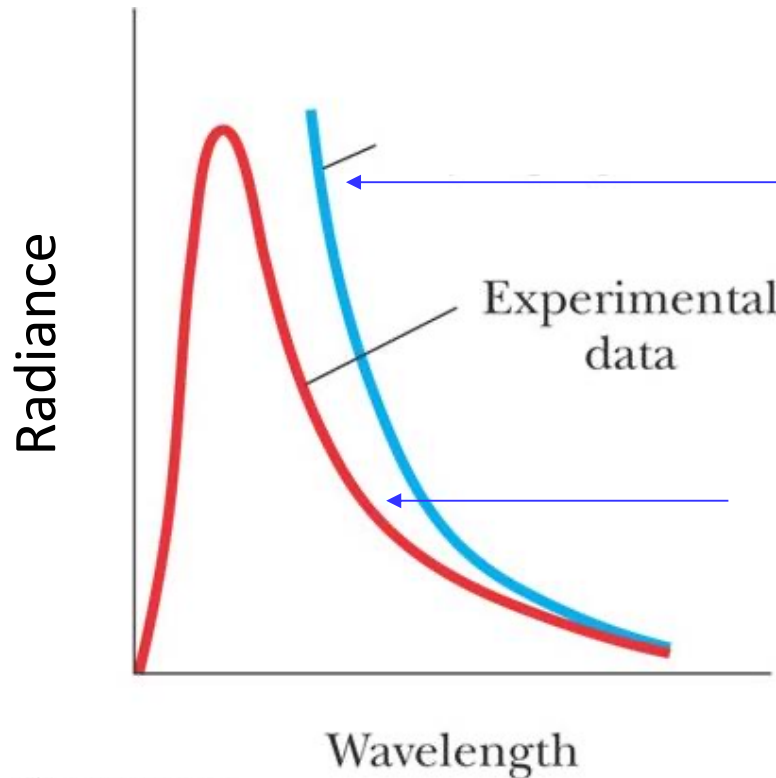

$$B_{\lambda}(T) = \frac{2ck_{\text{B}}T}{\lambda^4}$$

Rayleigh-Jean's law

$$B(T) = \frac{2hc^2}{\lambda^5} \frac{1}{e^{\frac{hc}{\lambda kT}} - 1}$$

Planck's eqn

Planck's Assumptions

The absorption and emission are done by oscillators present in the blackbody.

The oscillators emit or absorb energy when making a transition from one state to another.

Absorption and emission are **not done in piece-meal**; i.e., quantum states can't be populated by several partial absorption of energies.

The energy of an oscillator can have only certain discrete values E_n . It is not continuous as in $X= 1, 2, 3$ etc;. but jumps as in nX where for eg. $n=2$ and X is 1, 2, 3; then the numbers are 2, 4, 6). Notice they are not continuous.

According to Planck distribution of energies follows the equation below

$$E = h \nu \quad \nu \text{ is the frequency of oscillation}$$

h is Planck's constant (note ν is multiplied by a constant h)

.

Classical View Compared to Quantum Mechanical View

Copyright © The McGraw-Hill Companies, Inc. Permission required for reproduction or display.

Classical View

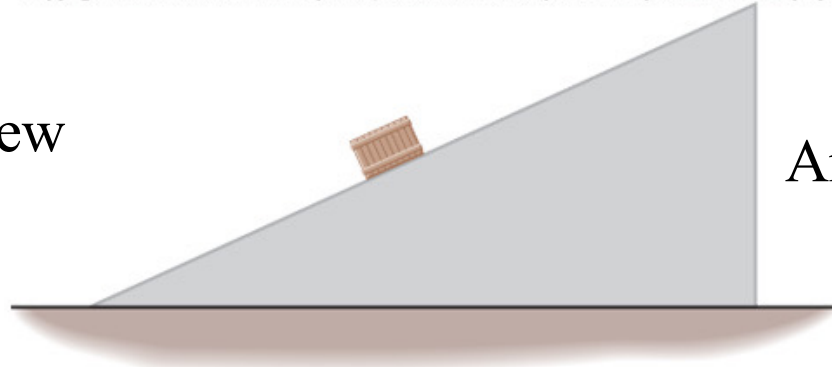

Any energy is possible

(a)

Quantum Mechanical View

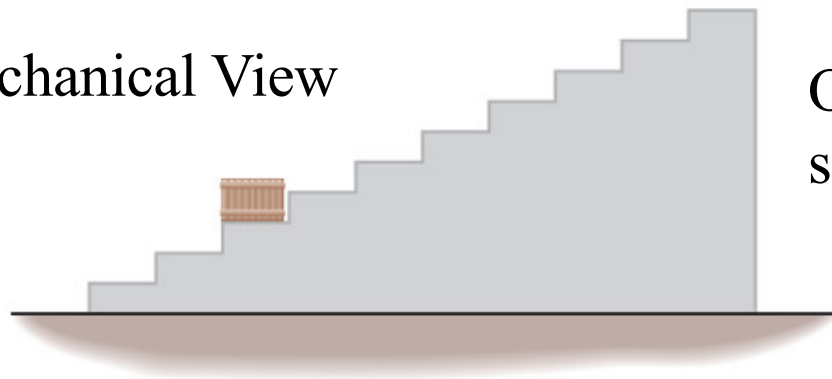

Only a few energy states are allowed

(b)

Planck's Model

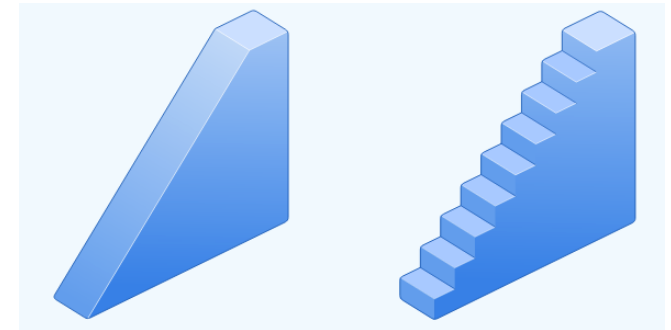
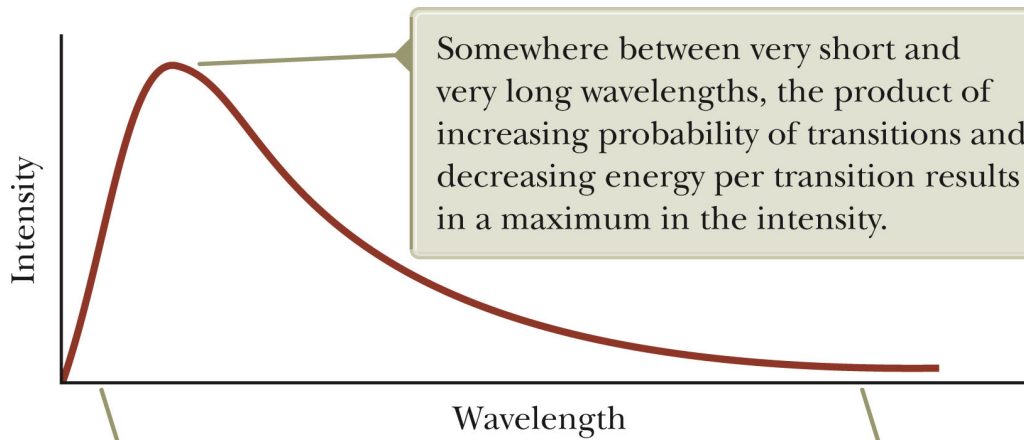

At short wavelengths, there is a large separation between energy levels, leading to a low probability of excited states and few downward transitions. The low probability of transitions leads to low intensity.

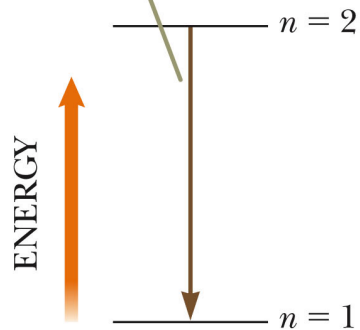

At long wavelengths, there is a small separation between energy levels, leading to a high probability of excited states and many downward transitions. The low energy in each transition leads to low intensity.

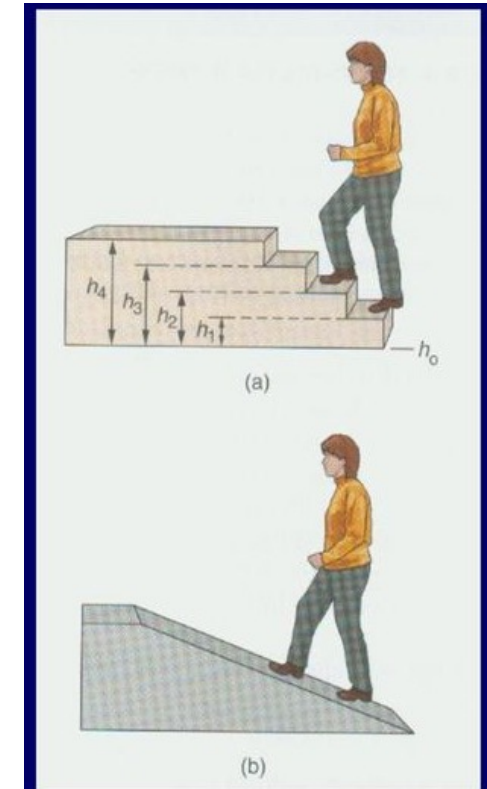
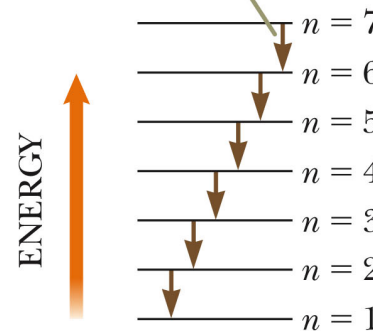

What we know, what is the problem, and who recognized it?

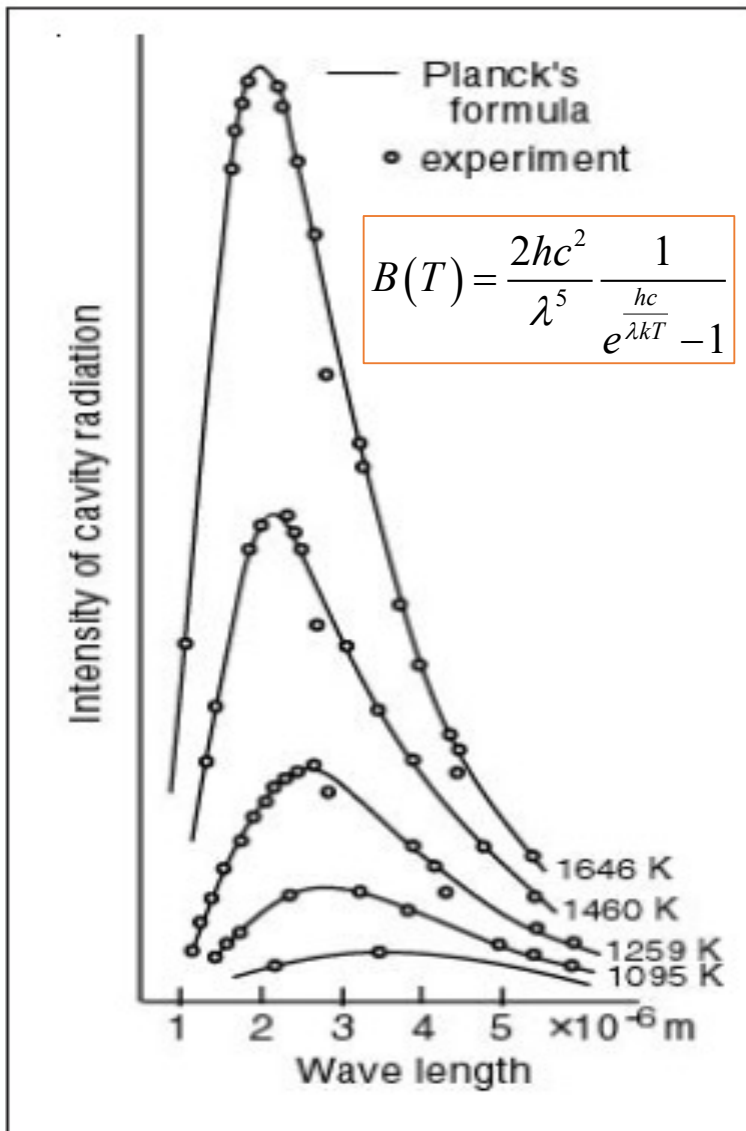

What is absorbing and emitting energy in a blackbody?

Oscillators

Why there is a maximum in the curve?

Why the maximum does not keep increasing with increasing temperature?

Quantization of energy

Planck abandoned the equipartition theorem and switched to probability. Probability of light absorption in large packets is small, \.

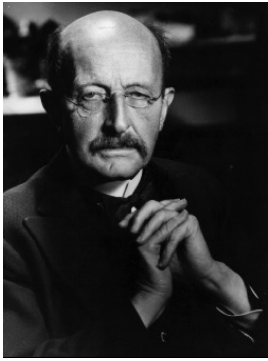

1858 – 1947

December 14, 1900 work presented
to German Physical Society.

Publication by Max Planck in 1900

*Zur Theorie des Gesetzes
der Energieverteilung im Normalspectrum;
von M. Planck.*

(Vorgetragen in der Sitzung vom 14. December 1900.)
(Vgl. oben S. 235.)

M. H.! Als ich vor mehreren Wochen die Ehre hatte, Ihre Aufmerksamkeit auf eine neue Formel zu lenken, welche mir geeignet schien, das Gesetz der Verteilung der strahlenden Energie auf alle Gebiete des Normalspectrums auszudrücken¹⁾, gründete sich meine Ansicht von der Brauchbarkeit der Formel, wie ich schon damals ausführte, nicht allein auf die anscheinend gute Uebereinstimmung der wenigen Zahlen, die ich Ihnen damals mitteilen konnte, mit den bisherigen Messungsergebnissen²⁾, sondern hauptsächlich auf den einfachen Bau der Formel und insbesondere darauf, dass dieselbe für die Abhängigkeit der Entropie eines bestrahlten monochromatisch schwingenden Resonators von seiner Schwingungsenergie einen sehr einfachen logarithmischen Ausdruck ergibt, welcher die Möglichkeit einer allgemeinen Deutung jedenfalls eher zu versprechen schien, als jede andere bisher in Vorschlag gebrachte Formel, abgesehen von der Wien'schen, die aber durch die Thatsachen nicht bestätigt wird.

Entropie bedingt Unordnung, und diese Unordnung glaubte ich erblicken zu müssen in der Unregelmässigkeit, mit der auch im vollkommen stationären Strahlungsfelde die Schwingungen des Resonators ihre Amplitude und ihre Phase wechseln, sofern man Zeitepochen betrachtet, die gross sind gegen die Zeit einer Schwingung, aber klein gegen die Zeit einer Messung. Die constante Energie des stationär schwingenden Resonators

The birth of the quantum theory

Planck made the extraordinary suggestion that states (oscillators) that absorb and emit light are quantized rather than being continuous.

Planck assumed that the energy of individual radiation oscillator in the cavity of a black body is quantized as per $E_n = nh\nu$.

The suggestion was considered bizarre and not physically realistic at the time but is now universally accepted by the scientific community.

The Nobel Prize in Physics 1918

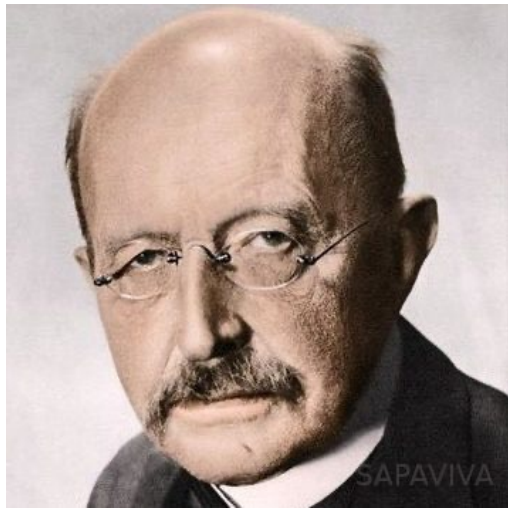

Max Planck

"in recognition of the services he rendered to the advancement of Physics by his discovery of energy quanta."

"New scientific truth usually becomes accepted, not because its opponents become convinced, but *because opponents gradually die* and because the rising generations are familiar with the new truth at the outset."

M. Planck, Naturwissenschaften, 33, 230 (1946).

Planck's radiation theory is, in truth, the most significant lodestar for modern physical research, and it seems that it will be a long time before the treasures will be exhausted which have been unearthed as a result of Planck's genius.

**Nobel Prize Award ceremony speech by
President of the Royal Swedish Academy
of Sciences, on June 1, 1920**

This marked a turning point in the history of physics. The importance of the discovery although not appreciated at first, its validity gradually became overwhelming as its application accounted for many discrepancies between observed phenomena and classical theory.

Who is Planck?

“h”

Planck is famous for a very important formula. The formula contains “Planck’s Constant,” or “h.” It is part of his theory on light and energy. The constant can be found on Planck’s tombstone in Germany. It reads: $h = 6.626 \times 10^{-34}$ Joules seconds (J s)

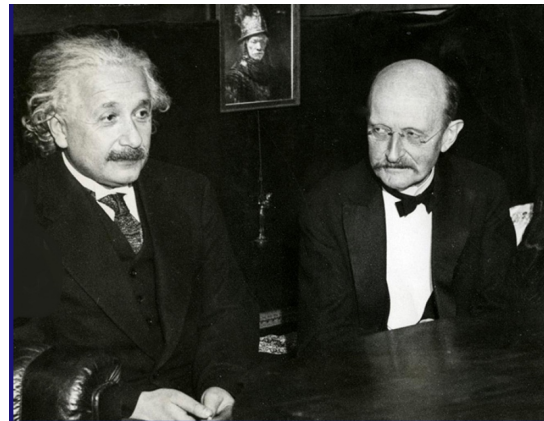
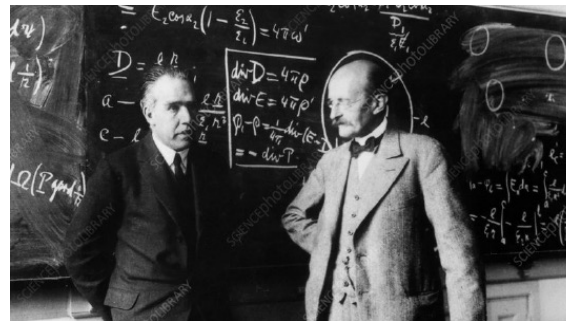
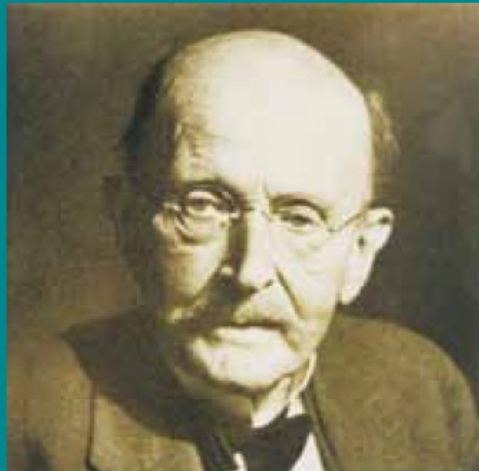

German physicist Max Planck publishes his groundbreaking study of the effect of radiation on “blackbody”, and the quantum theory of modern physics is born.

Scientists, such as [Einstein](#), Bohr, de Broglie, Schrodinger and Dirac, advanced Planck’s theory and made possible the development of the quantum theory that maintains that energy is both matter and a wave.

Quantum mechanics takes a probabilistic view of nature, sharply contrasting with classical mechanics, in which all precise properties of objects are, in principle, calculable.