

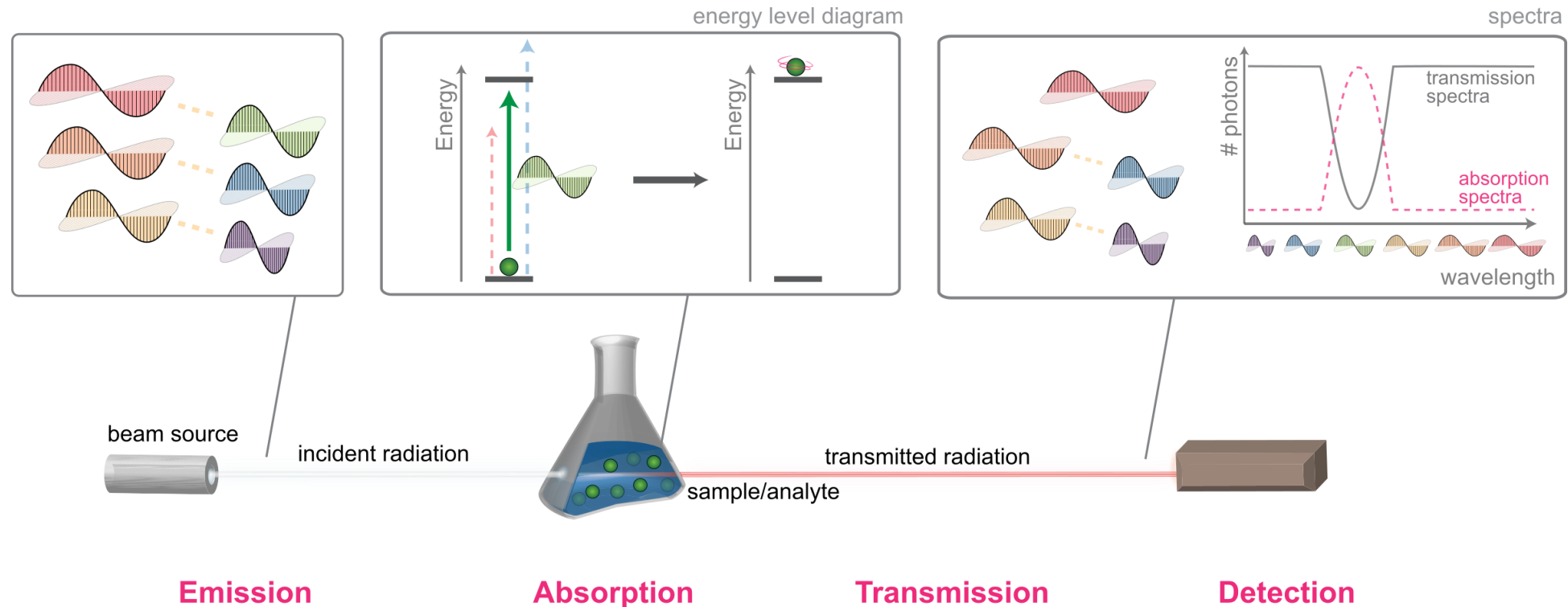
# ABSORPTION METHODS



# Content

- Fundamentals
- Astronomy
- Absorption spectroscopy – AAS, ROAS, TDLAS, CAES
- Cavity ring-down spectroscopy – CRDS
- Self-absorption and branching factors
- Optical frequency comb technique
- Pump-probe spectroscopy and microscopy
- ESR spectrometry, TAS, XAFS, Mössbauer spectroscopy

# Fundamentals



A white beam source – emitting light of multiple wavelengths – is focused on a sample. Upon striking the sample, photons that match the energy gap of the molecules present are absorbed in order to excite the molecule. Other photons transmit unaffected and, if the radiation is in the visible region (400-700nm), the sample color is the complementary color of the absorbed light. **By comparing the attenuation of the transmitted light with the incident, an absorption spectrum can be obtained.**

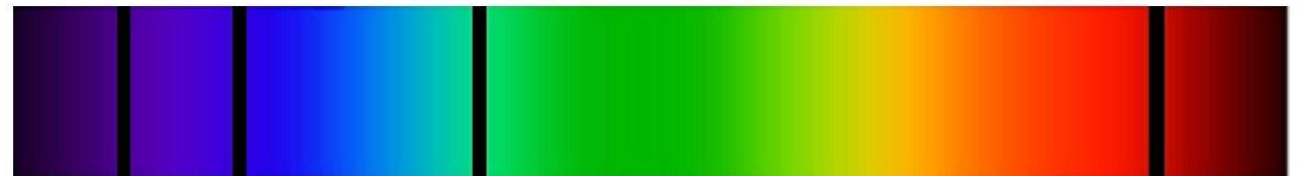
# Fundamentals

A material's absorption spectrum is the fraction of incident radiation absorbed by the material over a range of frequencies. **The absorption spectrum is primarily determined by the atomic and molecular composition of the material.** Radiation is more likely to be absorbed at frequencies that match the energy difference between two quantum mechanical states of the molecules. The absorption that occurs due to a transition between two states is referred to as an absorption line and a spectrum is typically composed of many lines.

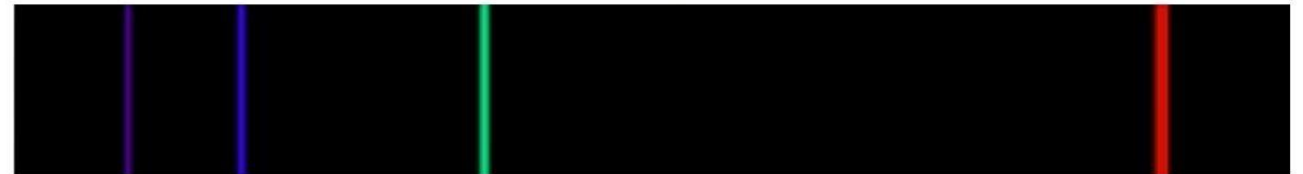
Continuous spectrum



Absorption spectrum



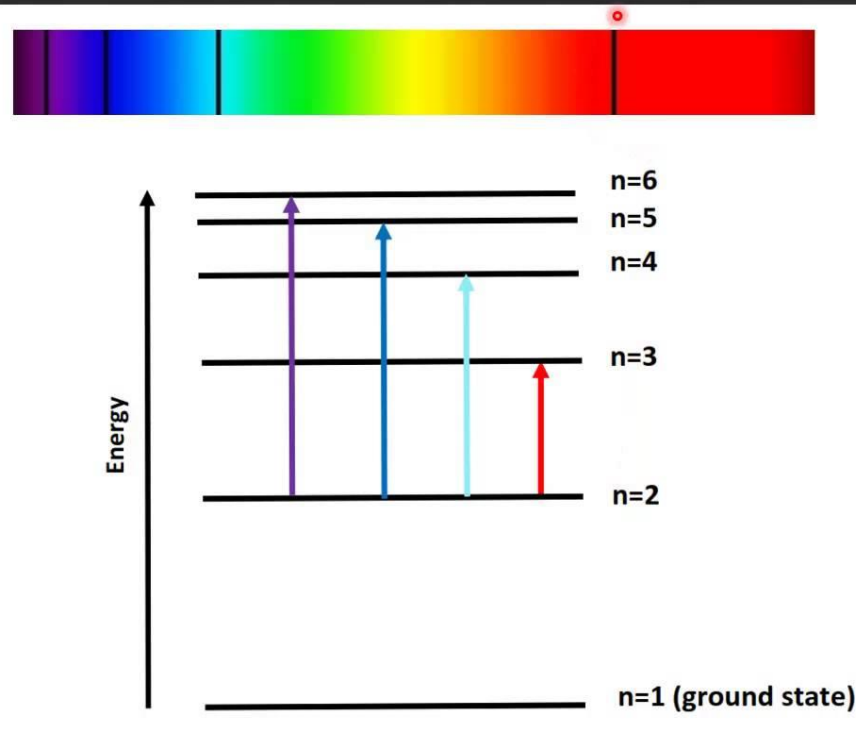
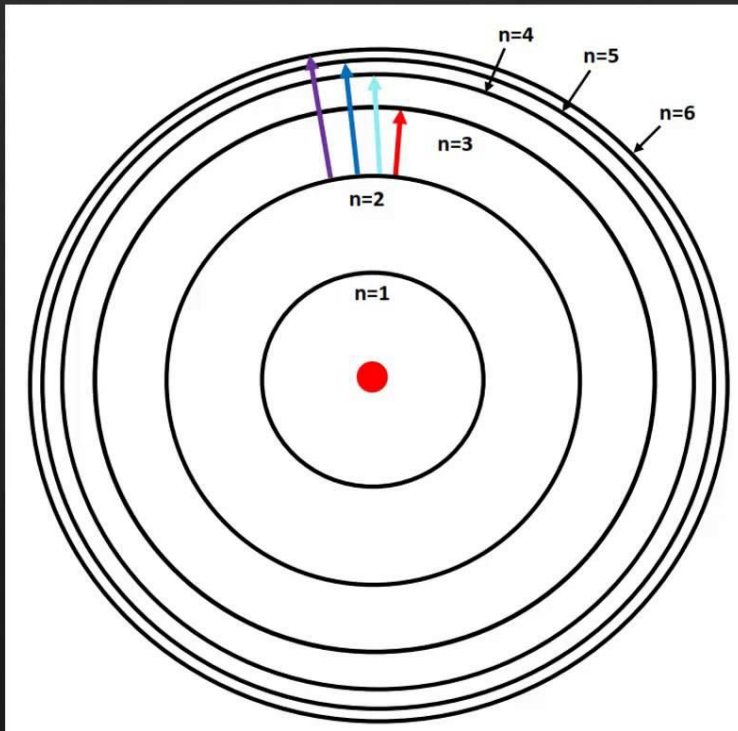
Emission spectrum



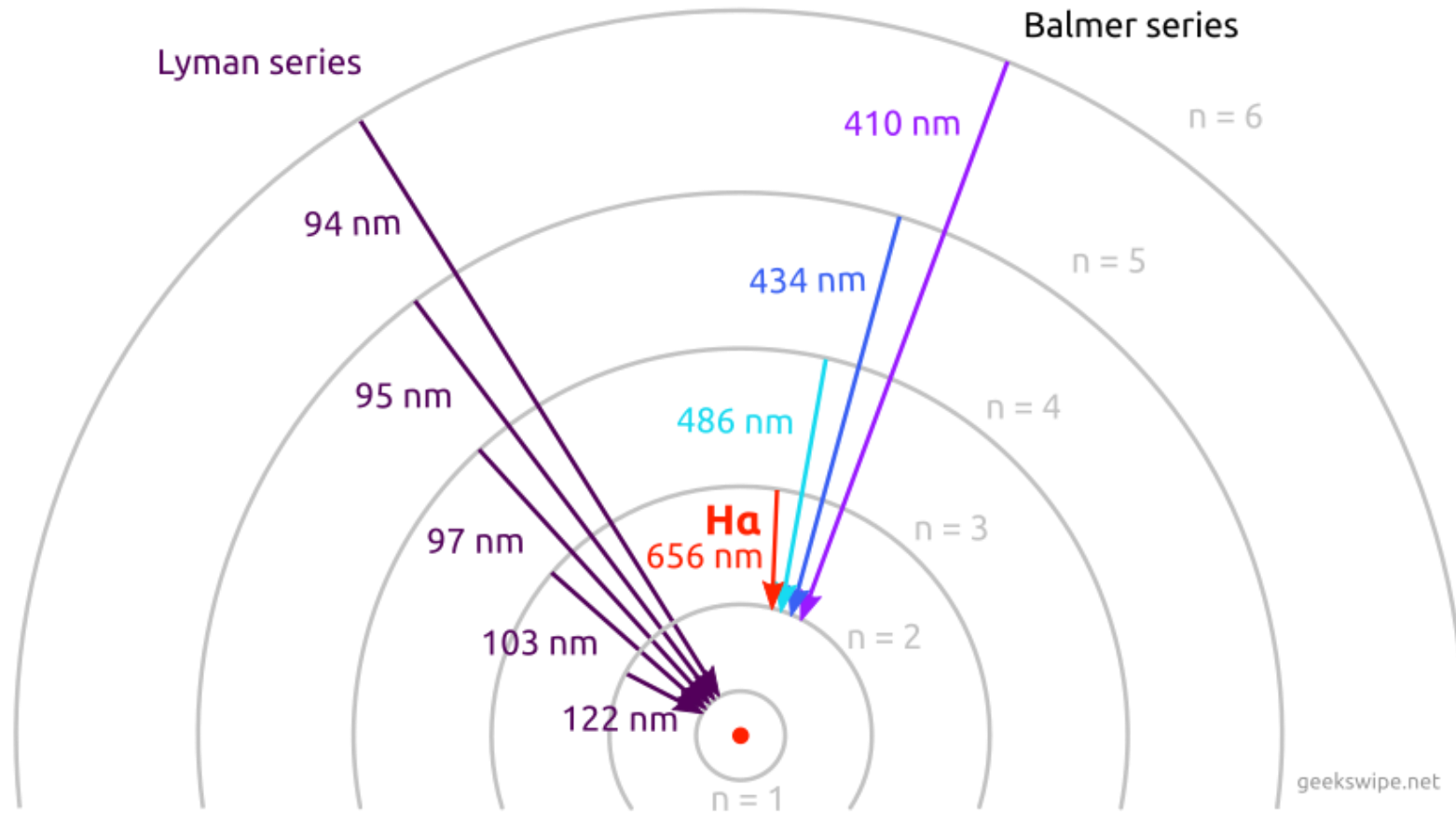
[https://commons.wikimedia.org/wiki/File:Spectral\\_lines\\_en.PNG?uselang=en-gb](https://commons.wikimedia.org/wiki/File:Spectral_lines_en.PNG?uselang=en-gb)

# Fundamentals

## Absorption spectrum



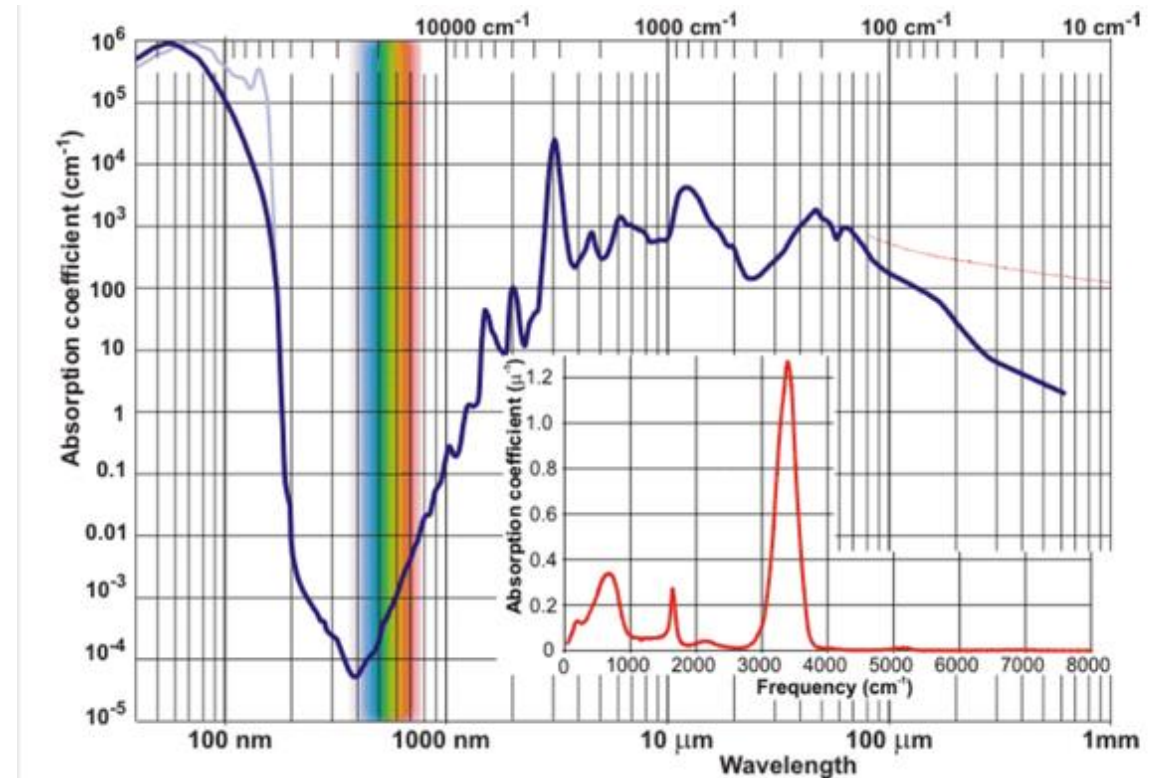
# Fundamentals



# Fundamentals

The frequencies where absorption lines occur, as well as their relative intensities, primarily depend on the electronic and molecular structure of the sample. **The frequencies will also depend on the interactions between molecules in the sample, the crystal structure in solids, and on several environmental factors (e.g., temperature, pressure, electromagnetic field).** The lines will also have a width and shape that are primarily determined by the spectral density or the density of states of the system.

Absorption spectrum of “clear” water



# Fundamentals

When light passes through a medium, some of the photons may interact with the matter (atoms, molecules, clusters etc.) and be absorbed (their energy being transformed in internal energy). As a result, the intensity decreases as light passes through the absorbing medium.

The relationship between the absorption  $A$  and the concentration of the absorbing atoms in an atom reservoir is given by the **Lambert–Beer law**.

$$I(\nu) = I_0(\nu) \exp(-k(\nu) l)$$

where  $I_0(\nu)$  is the intensity distribution of the incident radiation,  $l$  is the path length, and  $k(\nu)$  is the absorption coefficient of the plasma at the frequency  $\nu$ .

The width of the absorption line (profile of the spectral line) will be determined by several processes (Doppler-broadening, pressure and Stark broadening...), but the integral over the line is determined uniquely by the density of the absorbing species and atomic parameters

$$\int k(\nu) d\nu = \frac{A_{21}}{8\pi} \frac{g_2}{g_1} \lambda^2 n_1 \int g(\nu) d\nu = \frac{A_{21}}{8\pi} \frac{g_2}{g_1} \lambda^2 n_1$$



# Fundamentals

In general, we have to consider the transmission of radiation having a finite linewidth through a plasma whose absorption coefficient also has a finite linewidth. In this case we measure the "absorption"  $A$  of the radiation:

$$A = 1 - \frac{I_t}{I_0} = \frac{\int I_0(\nu)[1 - \exp(-k(\nu)l)]d\nu}{\int I_0(\nu)d\nu}$$

where  $I_t$  is the total intensity of the transmitted radiation, and  $I_0$  that of the incident radiation.

The **spectral line profile** of the incident radiation must be known, and an estimate of the absorption line shape is necessary; what is derived will then be the central (peak) value  $k_0$ . In the case of Doppler-broadened lines  $k_0$  can be written as:

$$k_0 = 1.62 \times 10^{-33} \lambda^3 \frac{g_2}{g_1} n_1 A_{21} \left( \frac{\mu}{\hat{T}} \right)^{1/2} \text{ m}^{-1}$$

Here  $\lambda$  is the wavelength of the transition in nm,  $g_1$  and  $g_2$  are the statistical weights of the lower and upper levels,  $A_{21}$  is the Einstein coefficient,  $n_1$  is the density of the lower level,  $T$  the temperature of the absorbing species in eV,  $\mu$  is the atomic mass (in atomic mass units).

# Fundamentals

- Law tends to break down at very high concentrations, especially if the material is highly scattering. If the radiation is especially intense, nonlinear optical processes can also cause variances.

## **Conditions that need to be fulfilled in order for Beer–Lambert law to be valid:**

1. attenuators must act independently of each other.
2. attenuating medium must be homogeneous in the interaction volume.
3. attenuating medium must not scatter the radiation
4. incident radiation must consist of parallel rays, each traversing the same length in the absorbing medium.
5. incident radiation should preferably be monochromatic or have at least a width that is narrower than that of the attenuating transition. Otherwise, a spectrometer as detector for the power is needed instead of a photodiode, which has not a selective wavelength dependence.
6. incident flux must not influence the atoms or molecules; it should only act as a non-invasive probe of the species under study. In particular, this implies that the light should not cause optical saturation or optical pumping, since such effects will deplete the lower level and possibly give rise to stimulated emission.

# Historical note

- 1729 - the law was discovered by Pierre Bouguer
- 1760 - Lambert's law stated that absorbance of a material sample is directly proportional to its thickness (path length).
- 1852 - August Beer discovered another attenuation relation. Beer's law stated that absorbance is proportional to the concentrations of the attenuating species in the material sample.
- modern derivation of the Beer–Lambert law combines the two laws and correlates the absorbance to both the concentrations of the attenuating species and the thickness of the material sample.

# Fundamentals

- Absorption lines are typically classified by the nature of the quantum mechanical change induced in the molecule or atom. **Rotational lines**, for instance, occur when the rotational state of a molecule is changed. Rotational lines are typically found in the microwave spectral region. **Vibrational lines** correspond to changes in the vibrational state of the molecule and are typically found in the infrared region. **Electronic lines** correspond to a change in the electronic state of an atom or molecule and are typically found in the visible and ultraviolet region. **X-ray absorptions** are associated with the excitation of inner shell electrons in atoms. These changes can also be combined (e.g. rotation-vibration transitions), leading to new absorption lines at the combined energy of the two changes.
- The energy associated with the quantum mechanical change primarily determines the frequency of the absorption line, but **the frequency can be shifted by several types of interactions**. **Electric** and **magnetic** fields can cause a shift. **Interactions** with neighboring molecules can cause shifts. For instance, absorption lines of the gas phase molecule can shift significantly when that molecule is in a liquid or solid phase and interacting more strongly with neighboring molecules.

# Application

**The most straightforward approach to absorption spectroscopy is to generate radiation with a source, measure a reference spectrum of that radiation with a detector and then re-measure the sample spectrum after placing the material of interest in between the source and detector.** The two measured spectra can then be combined to determine the material's absorption spectrum. The sample spectrum alone is not sufficient to determine the absorption spectrum because it will be affected by the experimental conditions—the spectrum of the source, the absorption spectra of other materials in between the source and detector and the wavelength dependent characteristics of the detector. The reference spectrum will be affected in the same way, though, by these experimental conditions and therefore the combination yields the absorption spectrum of the material alone.

A wide variety of radiation sources are employed in order to cover the electromagnetic spectrum.

1. source covering a broad range of wavelengths
2. novel source of broad-spectrum radiation is synchrotron radiation which covers all of these spectral regions.
3. other radiation sources generate a narrow spectrum, but the emission wavelength can be tuned to cover a spectral range. Examples of these include klystrons in the microwave region and lasers across the infrared, visible and ultraviolet region (though not all lasers have tunable wavelengths).

# Application

- The detector employed to measure the radiation power depends on the wavelength range of interest.
- Most detectors are sensitive to a fairly broad spectral range and the sensor selected will often depend more on the sensitivity and noise requirements of a given measurement.
- Examples of detectors common in spectroscopy:
  - a. heterodyne receivers in the microwave
  - b. bolometers in the millimeter-wave and infrared,
  - c. mercury cadmium telluride and other cooled semiconductor detectors in the infrared
  - d. photodiodes, photomultiplier tubes, spectrometers in the visible and ultraviolet.

# Astronomy

- Astronomical spectroscopy is a particularly significant type of remote spectral sensing. In this case, the objects and samples of interest are so distant from earth that electromagnetic radiation is the only means available to measure them
- Astronomical spectra contain both absorption and emission spectral information. Absorption spectroscopy has been particularly important for understanding **interstellar clouds** and determining that some of them contain molecules. Absorption spectroscopy is also employed in the study of **extrasolar planets**. Detection of extrasolar planets by the transit method also measures their absorption spectrum and allows for the **determination of the planet's atmospheric composition**, temperature, pressure, and scale height, and hence allows also for the determination of the planet's mass.
- Newton used a prism to split white light into a spectrum of color, and Fraunhofer's high-quality prisms allowed scientists to see dark lines of an unknown origin.
- In the 1860s, German natural philosophers Gustav Kirchhoff and Robert Bunsen showed that spectral lines are caused by different chemical elements absorbing or emitting light at specific energies. The dark lines found in the spectra of stars are absorption lines. These are caused by clouds of gas that absorb some of the star's light before it reaches Earth. These clouds can then emit this light at the same specific energies, creating emission lines.

# Astronomy

- Kirchhoff and Bunsen determined the energies of lines produced by different elements in the laboratory, and in 1864, British astronomer William Huggins and Irish-British astronomer Margaret Huggins showed that stars are made of some of these elements, and that they are mostly made of hydrogen.
- To date more than 20 000 absorption lines have been listed for the Sun between 293.5 and 877.0 nm, yet only approximately 75% of these lines have been linked to elemental absorption.
- By analyzing the width of each spectral line in an emission spectrum, both the elements present in a star and their relative abundances can be determined. Using this information stars can be categorized into stellar populations; Population I stars are the youngest stars and have the highest metal content (our Sun is a Pop I star), while Population III stars are the oldest stars with a very low metal content.

[https://en.wikipedia.org/wiki/Astronomical\\_spectroscopy](https://en.wikipedia.org/wiki/Astronomical_spectroscopy)

Foukal, Peter V. (2004). Solar Astrophysics. Weinheim: Wiley VCH. p. 69. ISBN 3-527-40374-4.

Gregory, Stephen A.; Michael Zeilik (1998). Introductory astronomy & astrophysics (4. ed.). Fort Worth [u.a.]: Saunders College Publ. p. 322. ISBN 0-03-006228-4.



# ABSORPTION SPECTROSCOPY



# Absorption spectroscopy

- **Absorption spectroscopy refers to spectroscopic techniques that measure the absorption of radiation, as a function of frequency or wavelength, due to its interaction with a sample. The sample absorbs energy, i.e., photons, from the radiating field. The intensity of the absorption varies as a function of frequency, and this variation is the absorption spectrum. Absorption spectroscopy is performed across the electromagnetic spectrum.**
- Absorption spectroscopy is employed as an **analytical chemistry tool** to determine the presence of a particular substance in a sample and, in many cases, to quantify the amount of the substance present. Infrared and ultraviolet-visible spectroscopy are common in analytical applications.
- There are a wide range of experimental approaches for measuring absorption spectra. The most common arrangement is to direct a generated beam of radiation at a sample and detect the intensity of the radiation that passes through it. The transmitted energy can be used to calculate the absorption. The source, sample arrangement and detection technique vary significantly depending on the frequency range and the purpose of the experiment.

# Resonant optical absorption spectroscopy

- resonant optical absorption spectroscopy (ROAS), also known as atomic absorption spectroscopy (AAS) —or optical absorption spectroscopy—OAS
- represents one of the straightforward ways for the determination of the absolute density of atomic and/or molecular species in gaseous discharges in an optically thin gaseous discharge
- **at a definite spectral line, the absolute density of states corresponding to a lower level of a chosen spectral transition can be determined by measuring so-called line absorption, i.e., an integral under spectral absorption line of interest, if the effective absorption lengths as well as the line width of both plasma and source spectral lines are known**
- the density of the absorbers can be determined using an external (reference) light source by measuring the attenuation in its intensity after passing a volume with the absorbing species (Mitchell and Zemansky)

# Resonant optical absorption spectroscopy

number density of the absorbing species in the lower (often ground) state can be determined using the following relation:

$$N_j = 1.2 \times 10^{12} k_0 \frac{\delta\sigma^p}{f_{ji}}$$

where  $N_j$  is in  $\text{cm}^{-3}$ ,  $k_0$  is in  $\text{cm}^{-1}$ ,  $\delta\sigma^p$  ( $\text{cm}^{-1}$ ) is the FWHM (full width at half maximum) of the plasma emission line,  $f_{ji}$  is the absorption oscillator strength, and  $j(i)$  stands for the lower(upper) state).

$f_{ji}$  can be determined as

$$f_{ji} = 1.5 \times 10^{-14} \frac{g_i}{g_j} A_{ij} \lambda_{ij}^2$$

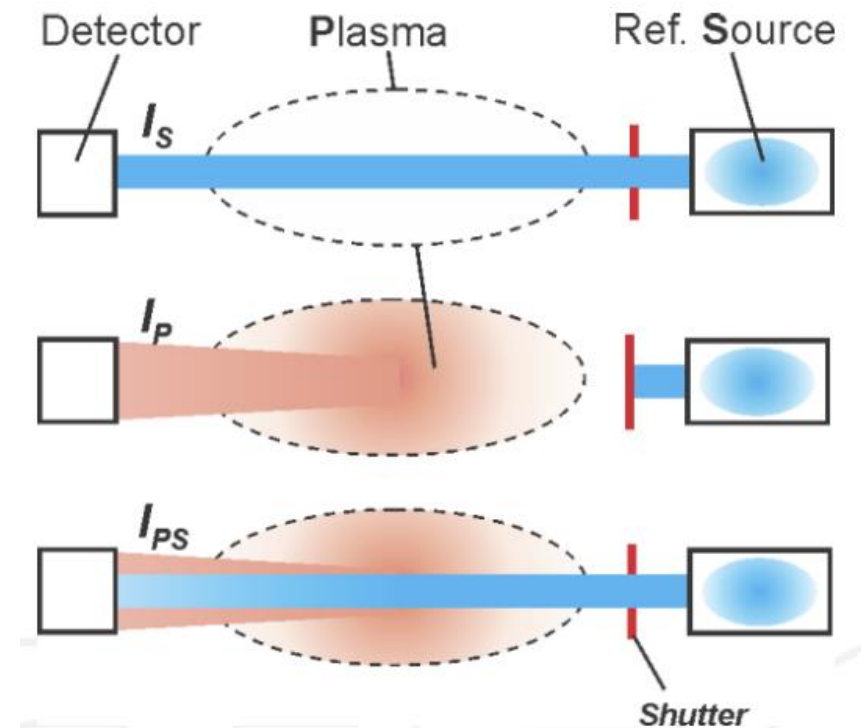
where  $g$  is the statistical weight of the corresponding energy level,  $A_{ij}$  is the emission probability corresponding to  $i \rightarrow j$  transition, and  $\lambda_{ij}$  is the transition wavelength.

# Resonant optical absorption spectroscopy

The line absorption  $A$  is normally determined from the experiment as

$$A = 1 - \frac{\text{transmitted radiation}}{\text{incident radiation}} = 1 - \frac{I_{PS} - I_P}{I_S}$$

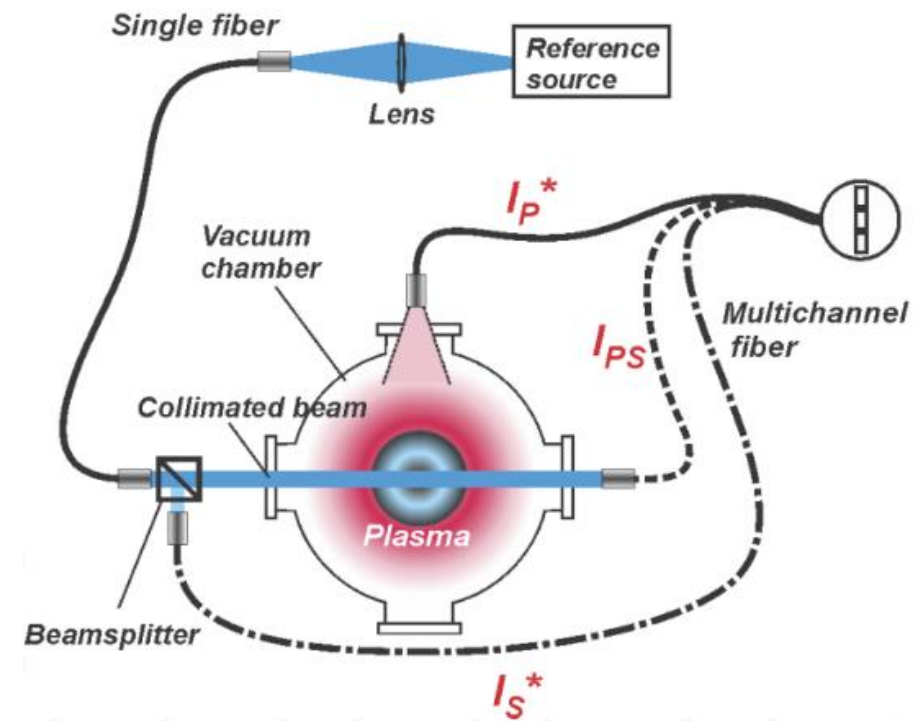
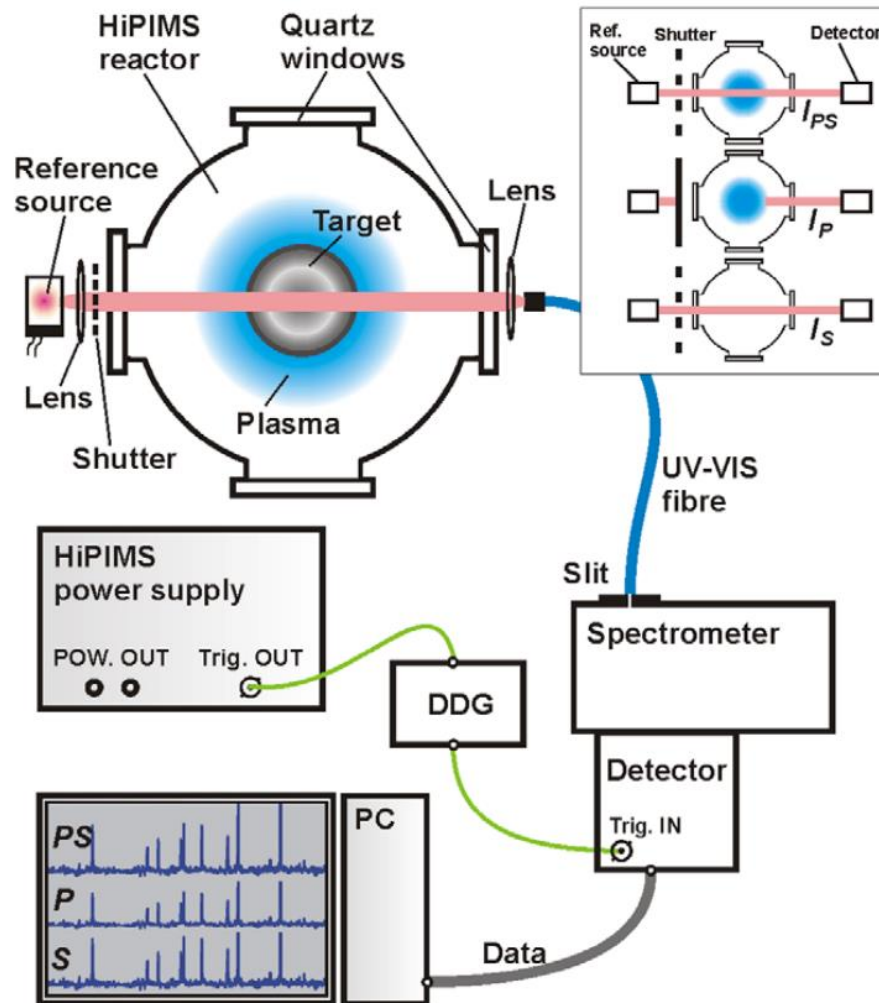
where  $I_{PS}$ ,  $I_P$  and  $I_S$  are respectively the intensities of the chosen spectral emission peak(s) from the reference source passing through the plasma, the plasma itself, and the reference source only.



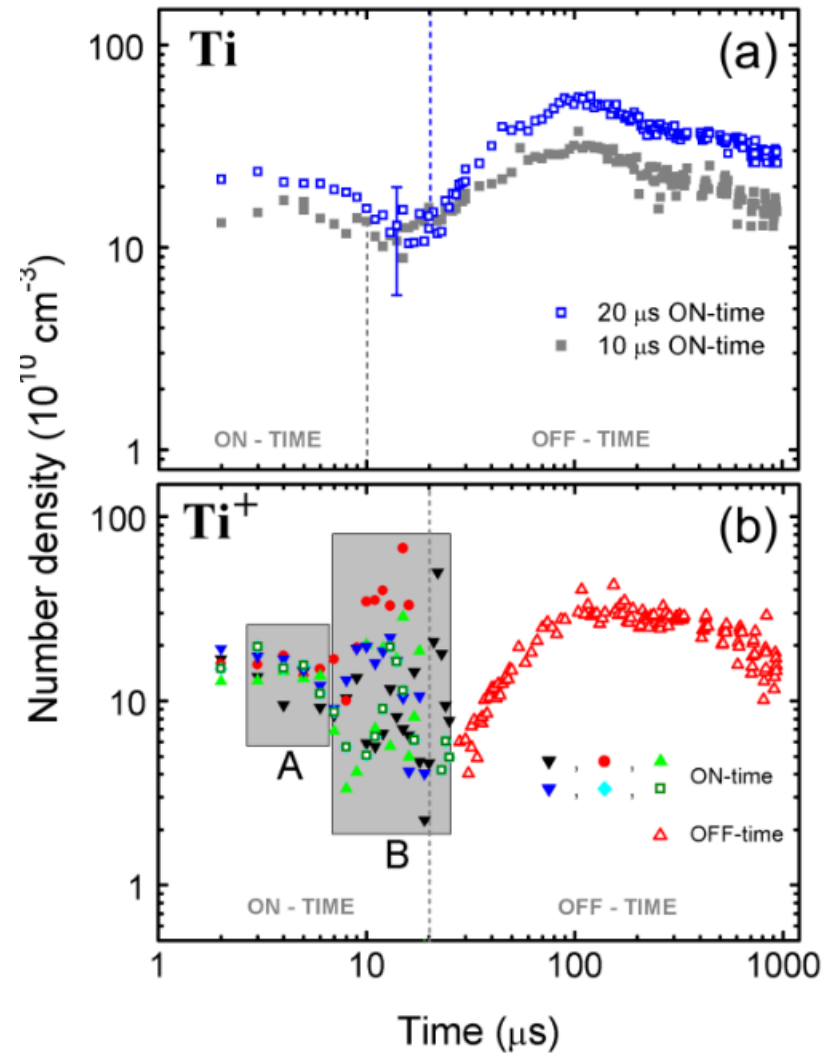
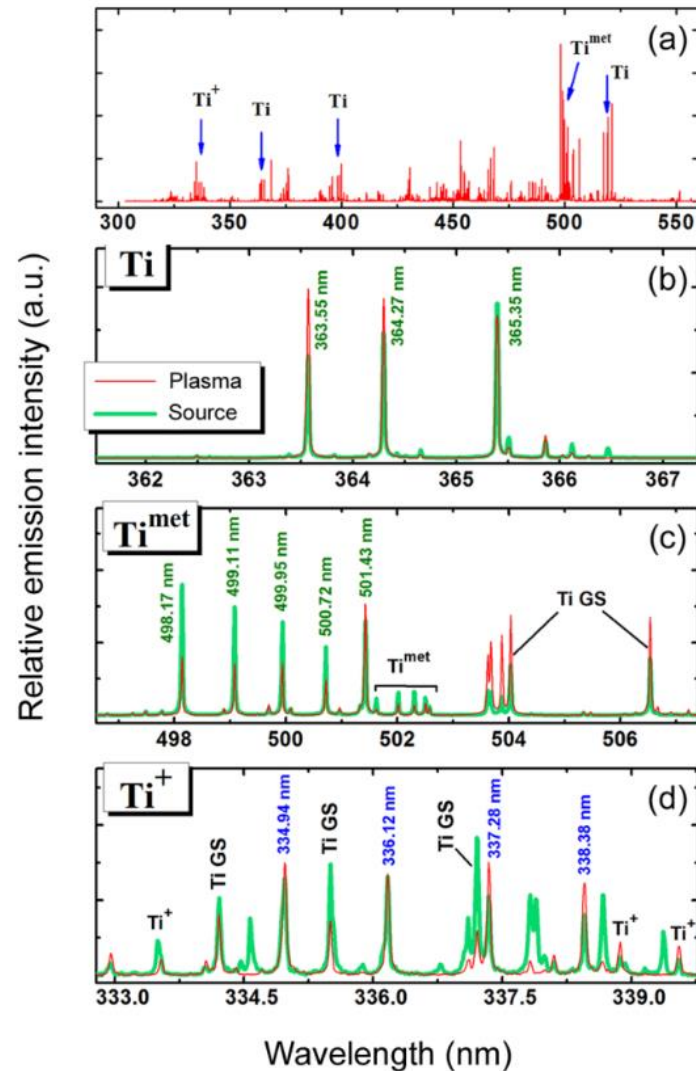
# Resonant optical absorption spectroscopy

- it requires optically thin plasmas, that is, ones where  $k_0L \ll 1$ . This is in particular related to the spectral line shape which is assumed to be Gaussian (Doppler broadening)
- if a non-thermal broadening prevails in plasma, the appropriate corrections should be applied to the expressions given above
- in the Doppler-limited case both the plasma and source temperatures (i.e., the corresponding line width) should be well defined
- in a typical ROAS setup, the reference source beam uniformity (level of collimation) is essential. If this is not the case, the absorption may reveal additional dependence along the beam. This fact promotes the implementation of diode lasers (DLs) as reference sources for ROAS
- due to inevitable instabilities in  $I_p$  and  $I_s$  signals, the  $I_s$  value normally should not exceed  $I_p$  by more than one order of magnitude:  $1 < I_s/I_p < 10$
- absorption length  $L$  should be well defined during the measurements. A significant error may be brought to the absolute density  $N_j$  determined by ROAS otherwise

# Resonant optical absorption spectroscopy



# Resonant optical absorption spectroscopy





# Laser absorption spectrometry (LAS ) and tunable diode laser absorption spectroscopy (TDLAS )

- use lasers to assess the concentration or amount of a species in gas phase by absorption spectrometry
- widely used technique for a variety of other applications, e.g., within the field of optical frequency metrology or in studies of light matter interactions.
- most common technique is tunable diode laser absorption spectroscopy
- advantages of LAS is:
  1. its ability to provide absolute quantitative assessments of species
  2. ability to achieve very low detection limits (of the order of ppb)
  3. possible to determine the temperature, pressure, velocity and mass flux of the gas

# Tunable diode laser absorption spectroscopy (TDLAS )

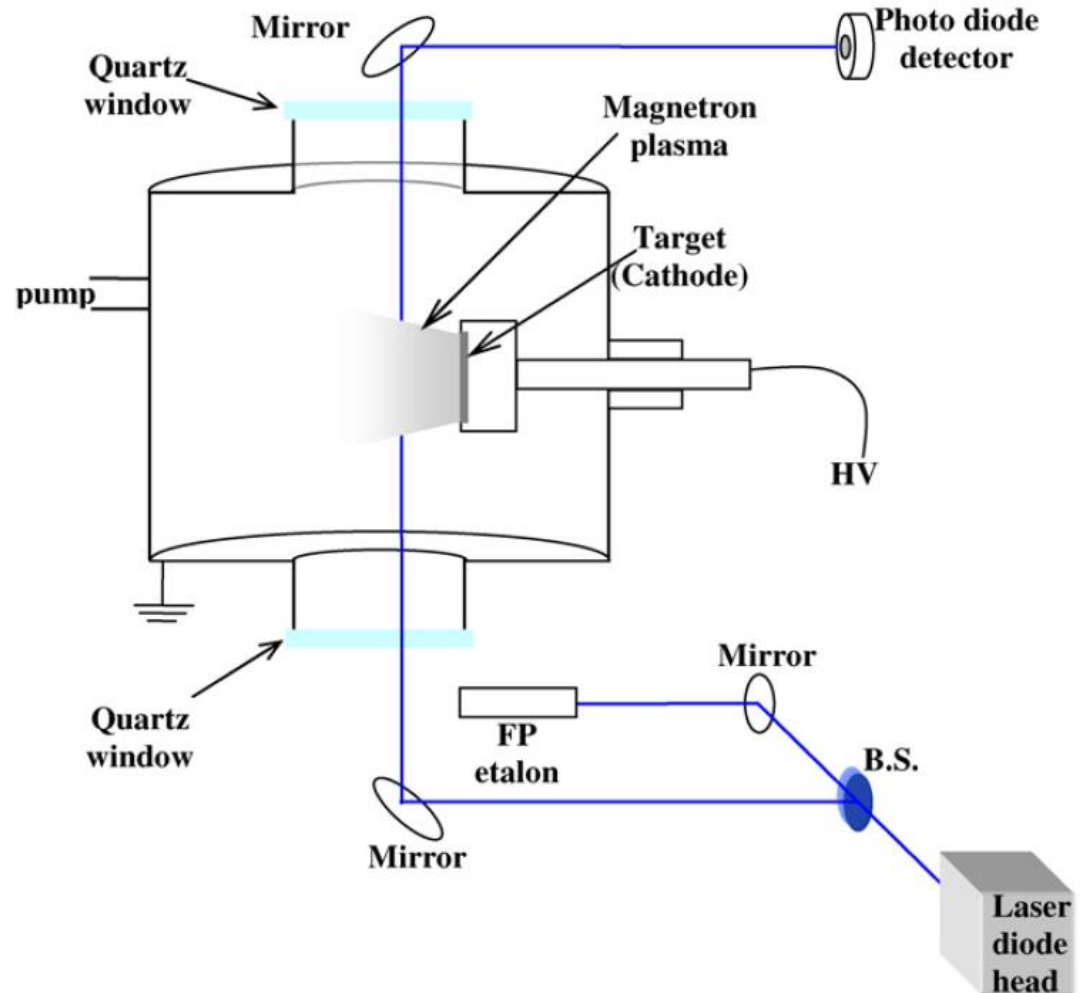
- biggest disadvantage is that it relies on a measurement of a small change in power from a high level; any noise introduced by the light source or the transmission through the optical system will deteriorate the sensitivity of the technique often limited to detection of absorbance  $\sim 10^{-3}$ , which is far away from the theoretical shot noise level, which for a single pass OAS technique is in the  $10^{-7} - 10^{-8}$  range
- The detection limit can be improved by
  1. reducing the noise,
  2. using transitions with larger transitions strengths or
  3. increasing the effective path length.
- the first can be achieved by the use of a modulation technique, the second can be obtained by using transitions in unconventional wavelength regions, whereas the third by using external cavities.

# Tunable diode laser absorption spectroscopy (TDLAS)

## TDLAS setup:

1. tunable diode laser light source
2. transmitting (i.e., beam shaping) optics
3. optically accessible absorbing medium
4. receiving optics and detector/s

The emission wavelength of the tunable diode laser is tuned over the characteristic absorption lines of a species in the gas in the path of the laser beam. This causes a reduction of the measured signal intensity, which can be detected by a photodiode, and then used to determine the gas concentration, temperature and velocity.



# Tunable diode laser absorption spectroscopy (TDLAS )

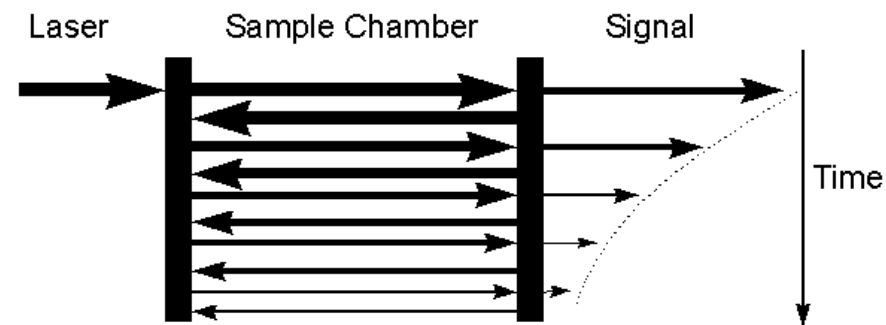
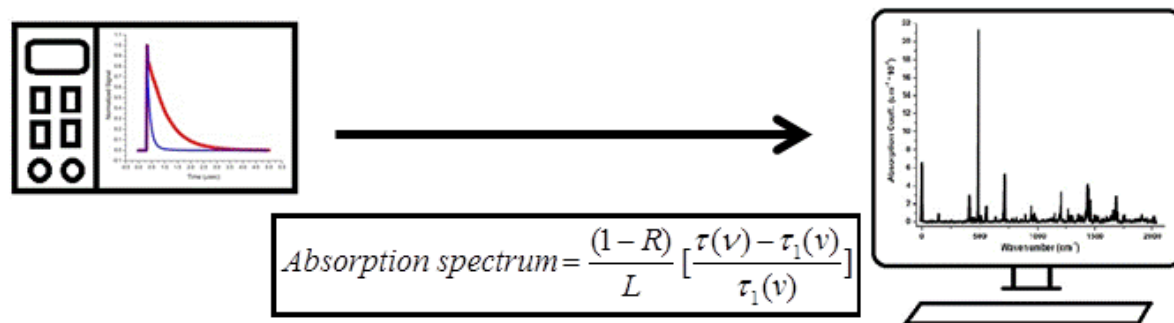
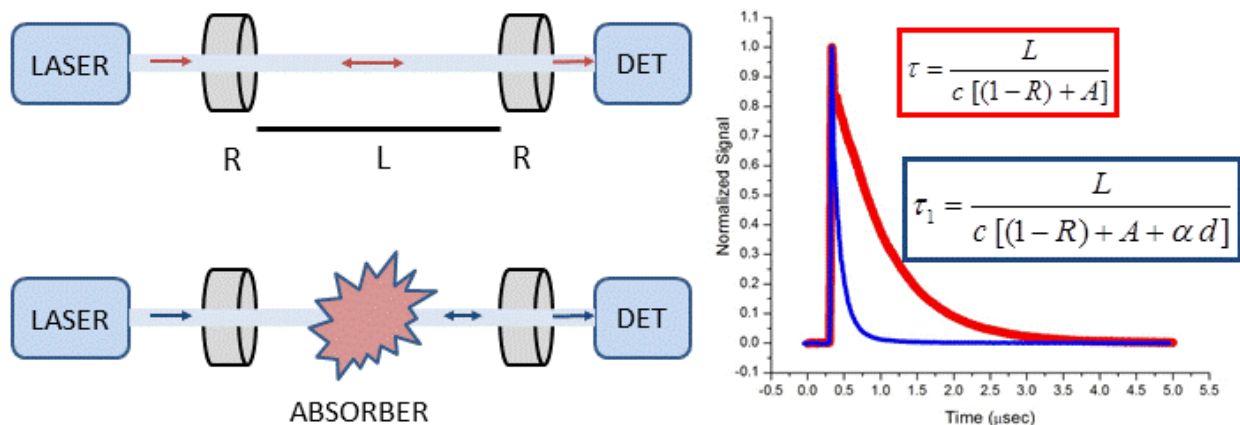
- **Concentration measurement** - The focus here is on a single absorption line in the absorption spectrum of a particular species of interest. To start with the wavelength of a diode laser is tuned over a particular absorption line of interest and the intensity of the transmitted radiation is measured. The transmitted intensity can be related to the concentration of the species present by the Beer-Lambert law
- **Temperature measurement** - the temperature of the absorbing species should be known. There are number of ways to measure the temperature. A widely applied method, which can measure the temperature simultaneously, uses the fact that the line strength is a function of temperature alone. Here two different absorption lines for the same species are probed while sweeping the laser across the absorption spectrum, the ratio of the integrated absorbance, is then a function of temperature alone
- **Velocity measurement** – The effect of a mean flow of the gas in the path of the laser beam can be seen as a shift in the absorption spectrum, also known as Doppler shift

# Cavity ring-down spectroscopy CRDS

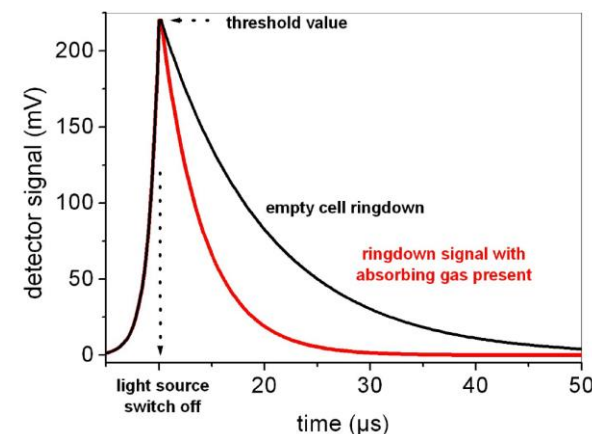
## Cavity-Ring Down Spectroscopy (CRDS)

CRDS measures the rate of decay of light intensity in a stable optical cavity

Not affected by the laser intensity



Mirror 1  
Mirror 2  
R=99.995%  
<http://www.chem.hope.edu/~polik/poster/crd96.htm>



$$I = A \exp(-t/\tau_{\text{crd}})$$

$c$  is the speed of light,  $\tau$  is the empty-cavity ring-down time, and  $\tau_1$  is the ring-down time for the cavity containing the absorber,  $L$  is the cavity length,  $R$  is mirror reflectivity,

<http://www.iup.uni-bremen.de/troposphere/research/laserabsorptionspectroscopy/cavityringdownspectroscopy/index.html>

<https://kb.osu.edu/bitstream/handle/1811/49453/Slide7.GIF?sequence=8&isAllowed=y>

# Cavity enhanced absorption spectrometry (CEAS)

- increasing the path length could improve the sensitivity of LAS. This can be obtained by placing the species inside a cavity in which the light bounces back and forth many times, whereby the interaction length can be increased considerably. This has led to a group of techniques denoted as **cavity enhanced AS (CEAS)**. The cavity can either be placed inside the laser, giving rise to intracavity AS, or outside, when it is referred to as an external cavity. Although the former technique can provide a high sensitivity, its practical applicability is limited by non-linear processes.
- External cavities can either be of multi-pass type, i.e. Herriott or White cells, or be of resonant type, most often working as a Fabry–Pérot (FP) etalon. Whereas the **multi-pass cells** typically can provide an enhanced interaction length of up to **~2 orders of magnitude**, the **resonant cavities** can provide a much larger path length enhancement, in the order of the finesse of the cavity,  $F$ , which for a balanced cavity with high reflecting mirrors with reflectivities of ~99.99–99.999% can be **~ $10^4$  to  $10^5$** .
- A problem with resonant cavities is that a high finesse cavity has narrow cavity modes, often in the low kHz range. Since cw lasers often have free-running linewidths in the MHz range, and pulsed even larger, it is difficult to couple laser light effectively into a high finesse cavity.

# Cavity ring-down spectroscopy CRDS

- is a highly sensitive optical spectroscopic technique that enables measurement of absolute optical extinction by samples that scatter and absorb light. It is used to study gaseous samples which absorb light at specific wavelengths, and in turn to **determine mole fractions down to the parts per trillion level ( $10^{12}$ )**.
- a typical CRDS setup consists of a laser that is used to illuminate a high-finesse optical cavity, which in its simplest form consists of two highly reflective mirrors. When the laser is in resonance with a cavity mode, intensity builds up in the cavity due to constructive interference. The laser is then turned off in order to allow the measurement of the exponentially decaying light intensity leaking from the cavity. During this decay, light is reflected back and forth thousands of times between the mirrors giving an effective path length for the extinction on the **order of a few kilometers**. The ringdown time of the cavity is a measure of absorbance by sample contained between the end mirrors. The large optical pathlength results in a highly sensitive absorption technique.
- If a light absorbing material is placed in the cavity, the mean lifetime decreases as fewer bounces through the medium are required before the light is absorbed. A CRDS setup measures how long it takes for the light to decay to  **$1/e$**  of its initial intensity, and this "**ringdown time**" can be used to calculate the concentration of the absorbing substance in the gas mixture in the cavity.

# Cavity ring-down spectroscopy CRDS

- highly sensitive direct absorption method for species in the gas-phase.
- CRDS is an effective method for different physical parameters such as temperature, pressure, strain
- in CRD spectroscopy the rate rather than the absolute magnitude of a change of intensity is determined.
- **advantages:**
  - intensity independent (in principle)
  - very long path-lengths
  - high spectral resolution possible
  - applicable over a wide spectral range
- it is often limited by drifts in the system between two consecutive measurements and a low transmission through the cavity
- spectra cannot be acquired quickly due to the monochromatic laser source
- analytes are limited both by the availability of tunable laser light at the appropriate wavelength and also the availability of high reflectance mirrors at those wavelengths
- requirement for laser systems and high reflectivity mirrors often makes CRDS orders of magnitude more expensive than some alternative spectroscopic techniques



**SELF-ABSORPTION**



# Self-absorption

- **The radiation emitted in a radiation source is absorbed by ground-state atoms of the same species. This phenomenon is known as self-absorption.** As the chance that an absorbed photon is re-emitted is  $<1$ , this causes the observed radiation to be weaker than the emitted radiation.
- As the absorption is maximal in the center of the line, self-absorption always leads to flatter line profiles, i.e., in peak height reduction and growth of spectral line widths
- **Self-absorption increases with the analyte number densities** in the source, **and with the number densities of emitting and absorbing analyte atoms** the intensity of a line tends to that given by Planck's law for black-body radiation

# Self-absorption

## MEASUREMENT OF METASTABLE-STATE DENSITIES BY SELF-ABSORPTION TECHNIQUE

- Absorption techniques are frequently used to find population densities of excited atomic or molecular states. For metastable and resonant levels, the populations are generally sufficient to produce a measurable absorption
- results are easily interpreted when the source and the absorbing medium both present lies having a Gaussian profile due to the Doppler effect.
- it is necessary to know the temperatures of the source and the absorbing medium.
- **in 1975 a new method in which the metastable atom concentration is determined from the ratio of the total intensities of two partially self-absorbed lines**, terminating on the level for which one wishes to determine the population

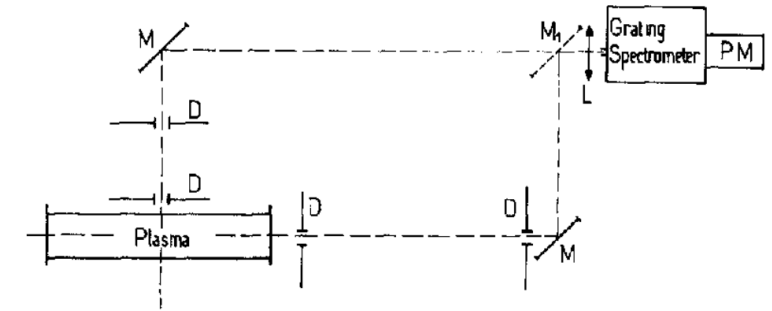


Fig 7 Optical arrangement to measure the ratio of line intensities parallel to and perpendicular to the plasma  
D, diaphragm, M, mirror, M<sub>1</sub>, removable mirror, L, lens

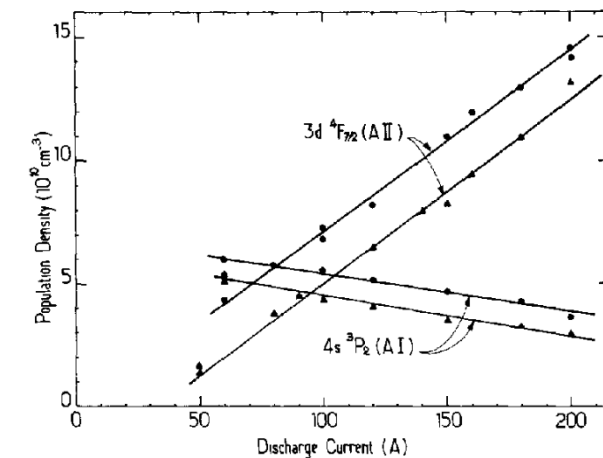
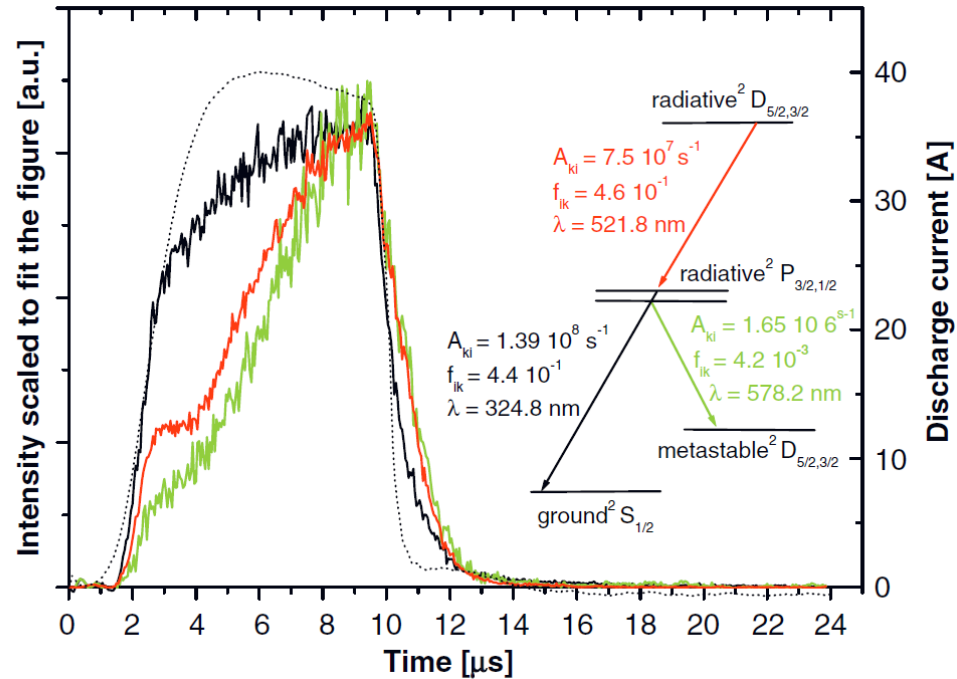


Fig 8. Neutral and ionic metastable densities as functions of the discharge current (●),  $5 \times 10^{-2}$  torr, (▲),  $10^{-1}$  torr

# Self-absorption and branching factors



- line 324,8 nm (black) and 578,2 nm (green)
- are emitted from the same level
  - their time evolution is very different

324,8 nm (black) line is **resonant line** with high oscillator strength – it is subject of **strong self-absorption**

# Titanium

Ti neutral

$$J = 4 \text{ _____ } 0.048 \text{ eV}$$

$$J = 3 \text{ _____ } 0.021 \text{ eV}$$

$$J = 2 \text{ _____ } 0.000 \text{ eV}$$

Ti ion

$$J = 9/2 \text{ _____ } 0.049 \text{ eV}$$

$$J = 7/2 \text{ _____ } 0.028 \text{ eV}$$

$$J = 5/2 \text{ _____ } 0.012 \text{ eV}$$

$$J = 3/2 \text{ _____ } 0.000 \text{ eV}$$

Ti  $a^3F$

$$[Ti_{ground}] = \sum_{J=2}^4 [Ti_{ground,J}]$$

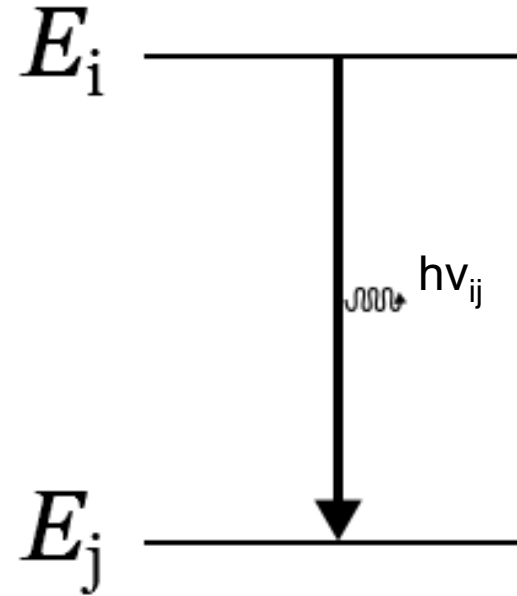
ground state

Ti<sup>+</sup>  $a^4F$

$$[Ti^+_{ground}] = \sum_{J=3/2}^{9/2} [Ti^+_{ground,J}]$$

# Theory

- $I_{ij} = N_i A_{ij} h \nu_{ij}$ 
  - $N_i$  is concentration upper state
  - $A_{ij}$  is Einstein coefficient for spontaneous emission
  - $\nu_{ij}$  is frequency

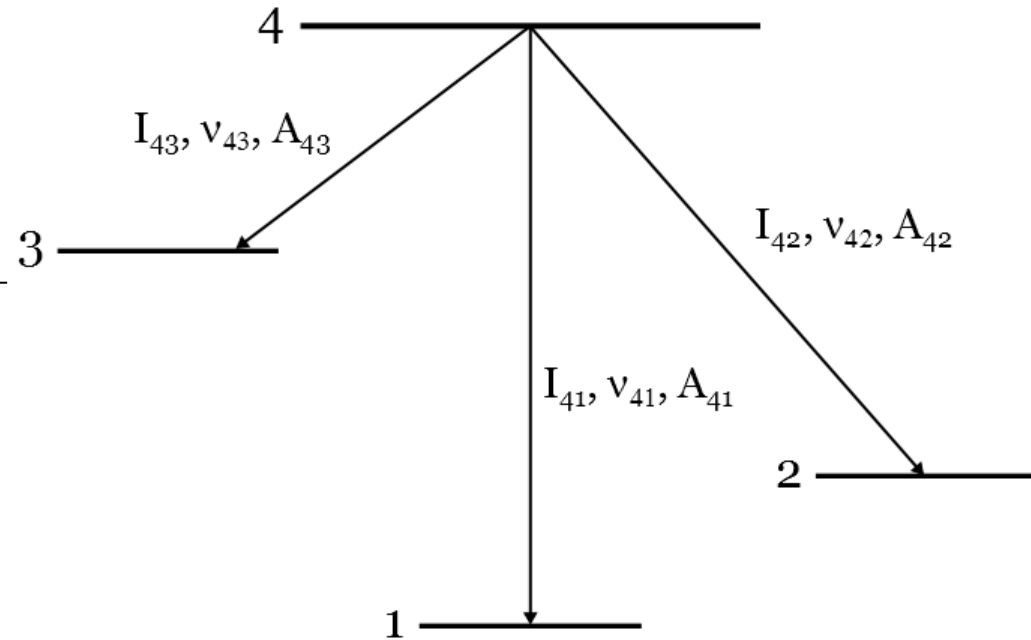


- intensity ratio of two spectral lines from the same upper level?

- at least two spectral lines from the same upper level
  - branching fractions  $\Gamma$

- non-absorption case

$$\Gamma = \frac{\frac{I_{41}}{h\nu_{41}}}{\frac{I_{41}}{h\nu_{41}} + \frac{I_{42}}{h\nu_{42}} + \frac{I_{43}}{h\nu_{432}}} = \frac{A_{41}}{A_{41} + A_{42} + A_{43}}$$



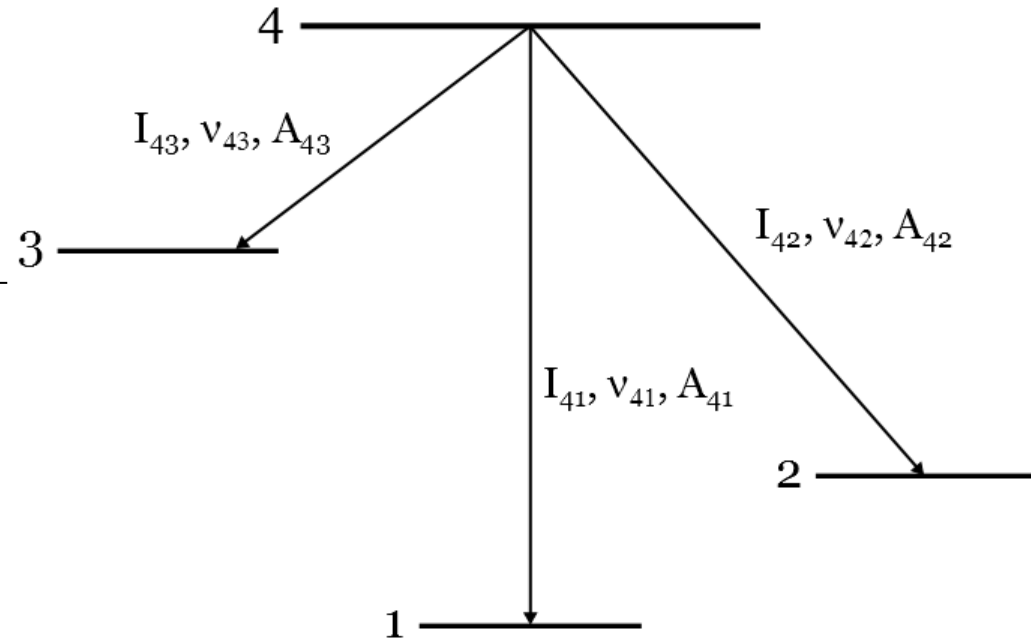
- at least two spectral lines from the same upper level
  - branching fractions  $\Gamma$

- non-absorption case

$$\Gamma = \frac{\frac{I_{41}}{h\nu_{41}}}{\frac{I_{41}}{h\nu_{41}} + \frac{I_{42}}{h\nu_{42}} + \frac{I_{43}}{h\nu_{432}}} = \frac{A_{41}}{A_{41} + A_{42} + A_{43}}$$

- self-absorption case

$$\Gamma = \frac{\frac{I_{41}}{h\nu_{41}}}{\frac{I_{41}}{h\nu_{41}} + \frac{I_{42}}{h\nu_{42}} + \frac{I_{43}}{h\nu_{43}}} = \frac{A_{41}g_{41}}{A_{41}g_{41} + A_{42}g_{42} + A_{43}g_{43}}$$





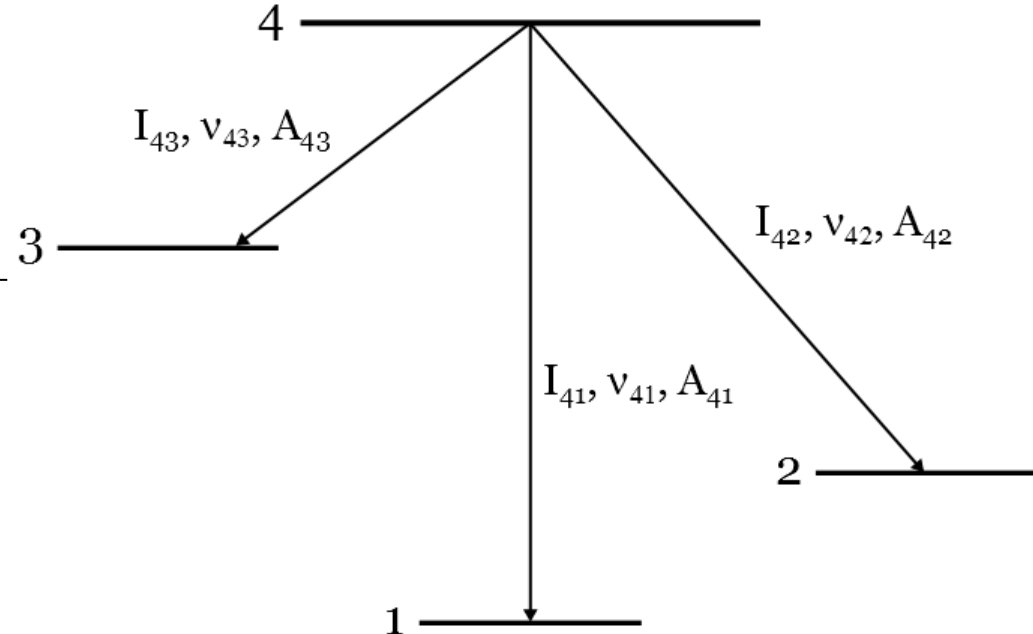
- at least two spectral lines from the same upper level
  - **branching fractions  $\Gamma$**

- non-absorption case

$$\Gamma = \frac{\frac{I_{41}}{h\nu_{41}}}{\frac{I_{41}}{h\nu_{41}} + \frac{I_{42}}{h\nu_{42}} + \frac{I_{43}}{h\nu_{432}}} = \frac{A_{41}}{A_{41} + A_{42} + A_{43}}$$

- self-absorption case

$$\Gamma = \frac{\frac{I_{41}}{h\nu_{41}}}{\frac{I_{41}}{h\nu_{41}} + \frac{I_{42}}{h\nu_{42}} + \frac{I_{43}}{h\nu_{43}}} = \frac{A_{41}g_{41}}{A_{41}g_{41} + A_{42}g_{42} + A_{43}g_{43}}$$



- $g_{ij}(k_{ij}^0 L)$  is escape factor R. Mewe, Br. J. Appl. Phys. **18**, (1967), 107
  - $L$  is plasma depth (constant in our case)
  - $k_{ij}^0(\lambda, m_0, k_b, T_g, g_i, g_j, A_{ij}, n_j)$  is re-absorption coefficient

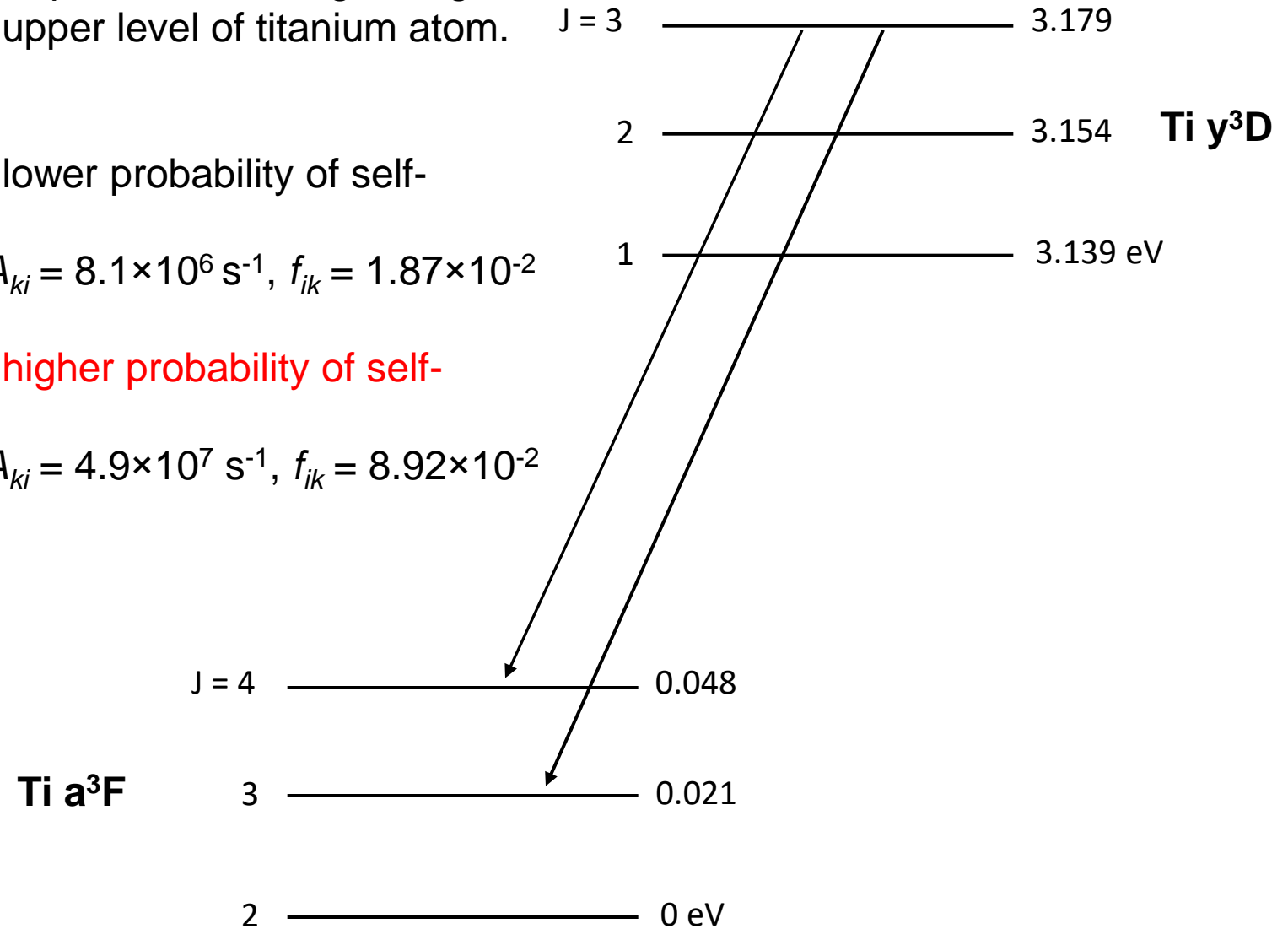
We choose as example two lines originating from the same excited upper level of titanium atom.

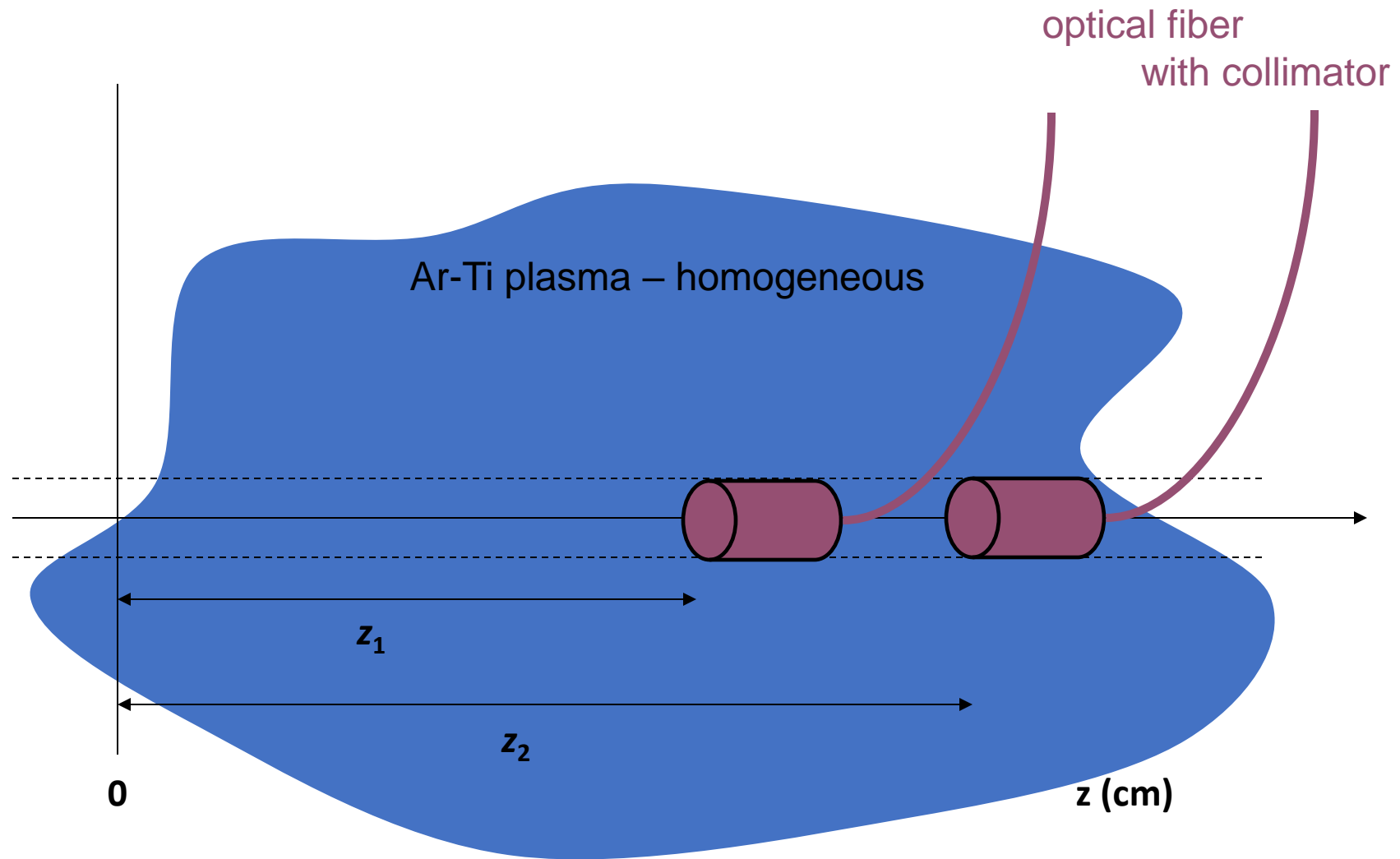
$\lambda_1 = 392.45 \text{ nm}$  – lower probability of self-absorption

$$A_{ki} = 8.1 \times 10^6 \text{ s}^{-1}, f_{ik} = 1.87 \times 10^{-2}$$

$\lambda_2 = 395.82 \text{ nm}$  – higher probability of self-absorption

$$A_{ki} = 4.9 \times 10^7 \text{ s}^{-1}, f_{ik} = 8.92 \times 10^{-2}$$

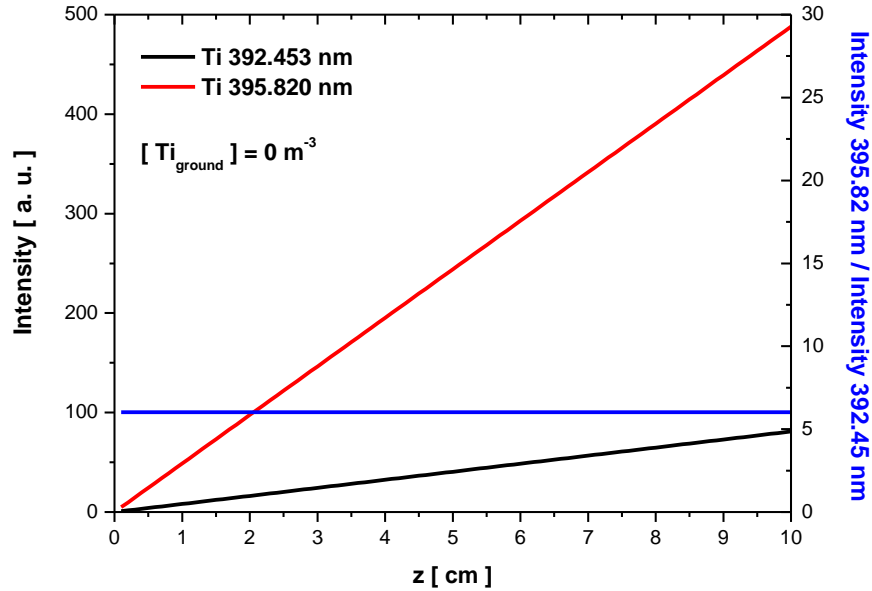




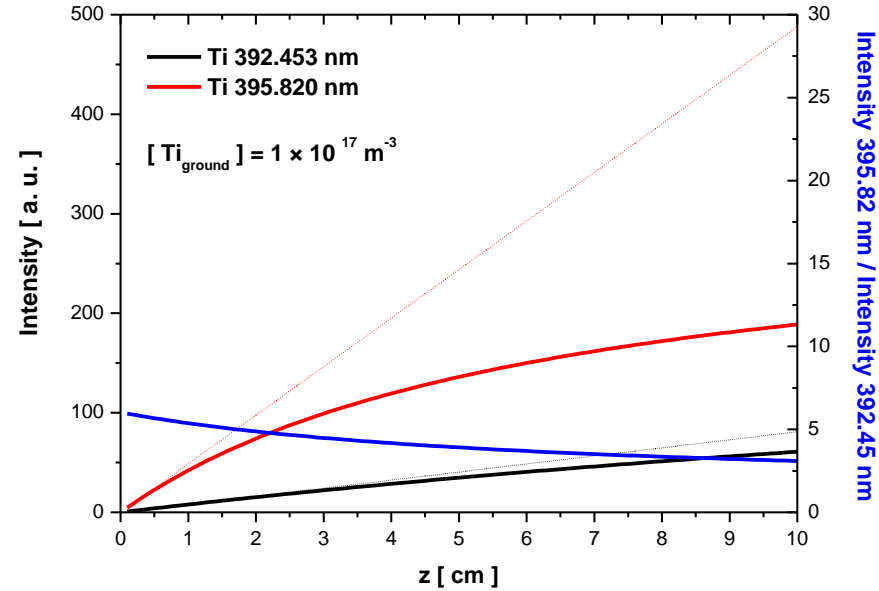
What is the intensity collected from the cylinder of length  $z_1$  or  $z_2$  filled by plasma ?

How does the line intensity depends on  $z$  position of the fiber ?

no absorption  $[Ti_{\text{ground}}] = 0 \text{ m}^{-3}$



absorption  $[Ti_{\text{ground}}] = 1 \times 10^{17} \text{ m}^{-3}$



**intensity collected from plasma cylinder of length z**

increases linearly with z

increases slower than linearly with z

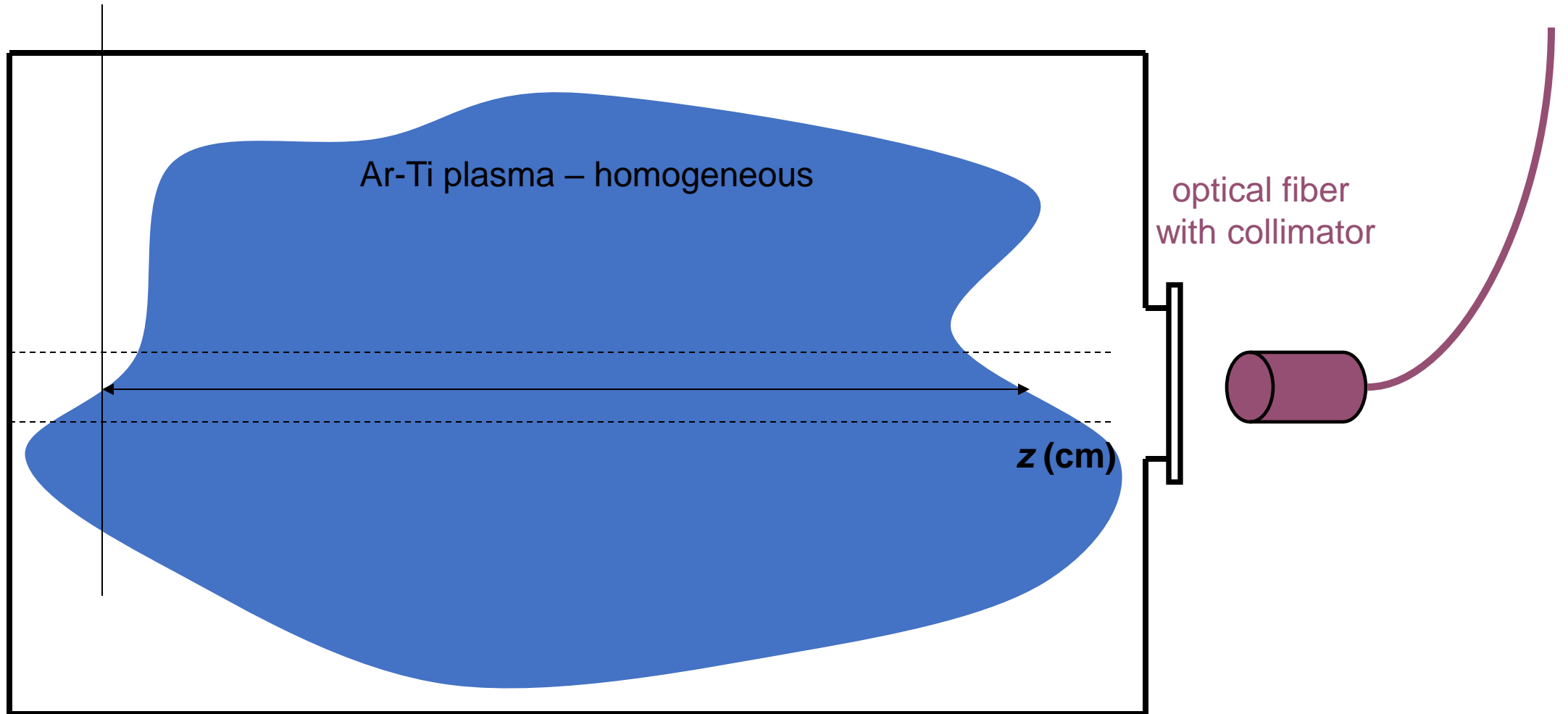
**ratio of measured Ti line intensities originating from the same upper level**

does not depend on z

is a function of z ( $g_i$  - escape factor)

$$\frac{I_1}{I_2} = \frac{A_1}{A_2}$$

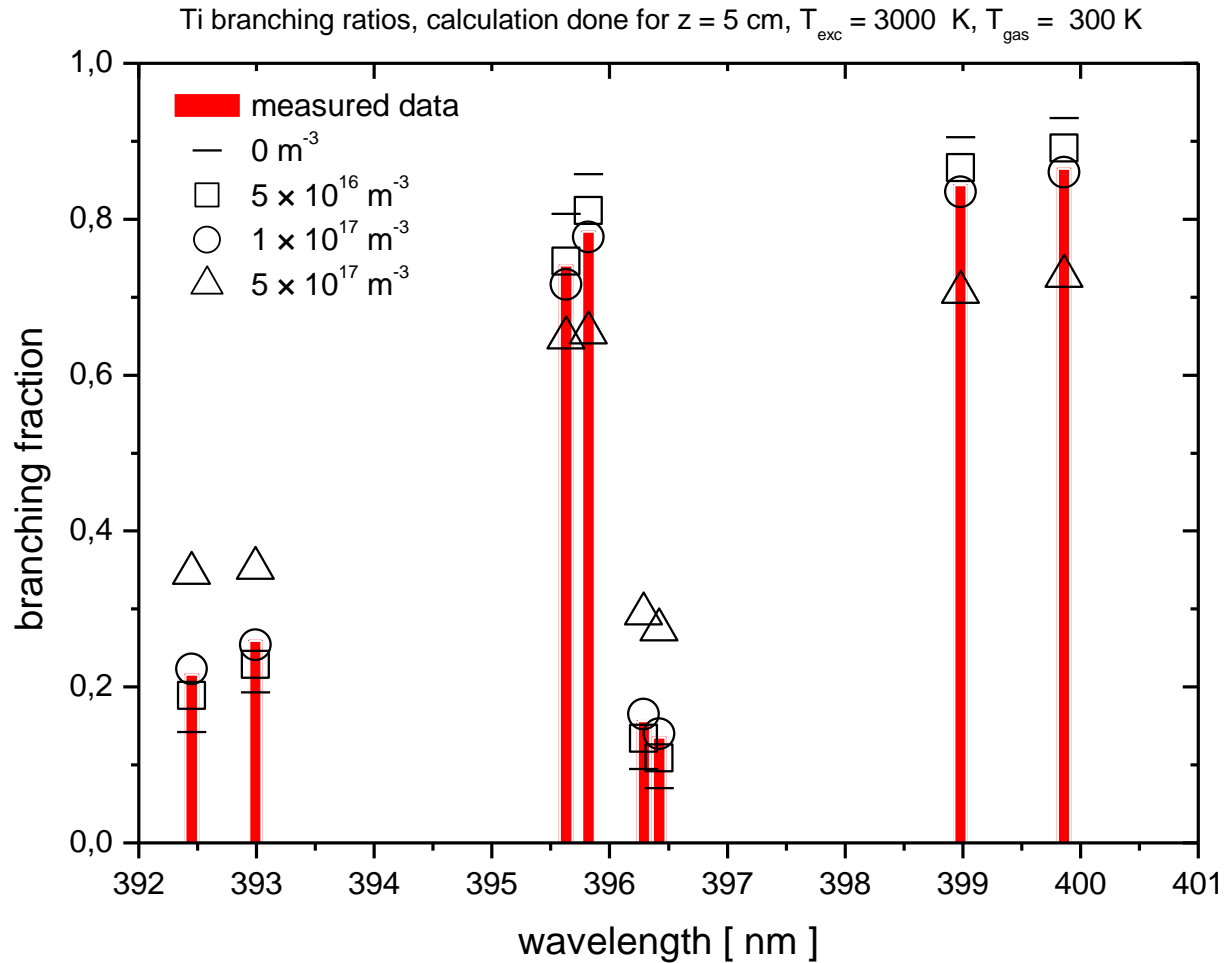
$$\frac{I_1}{I_2} = \frac{A_1 g_1}{A_2 g_2}$$



Reality : plasma is inside a vessel, fiber is fixed outside, plasma is observed through observation window, plasma length  $z$  is given and can not be changed

Ti and Ti<sup>+</sup> line intensities can be measured from plasma cylinder of length  $z$

## example of measured branching fraction for a HIPIMS discharge – Ti lines



$$\Gamma = \frac{\frac{I_{41}}{h\nu_{41}}}{\frac{I_{41}}{h\nu_{41}} + \frac{I_{42}}{h\nu_{42}} + \frac{I_{43}}{h\nu_{43}}} = \frac{A_{41}g_{41}}{A_{41}g_{41} + A_{42}g_{42} + A_{43}g_{43}}$$

$g_{ij}(k_{ij}^0 L)$  is escape factor

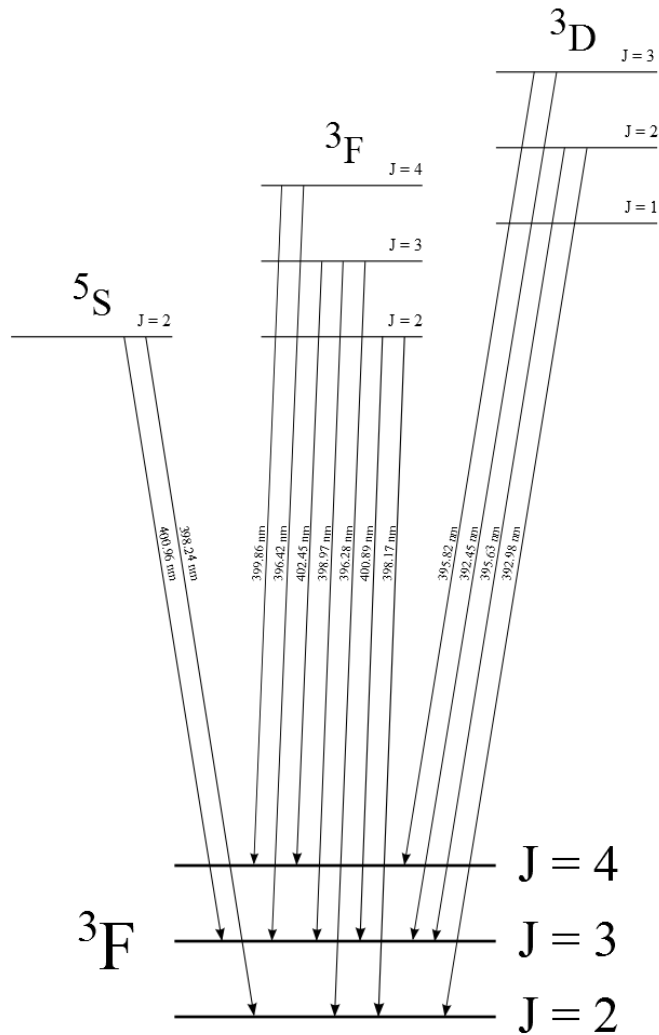
$L$  is plasma depth (constant in our case)

$k_{ij}^0(\lambda, m_0, k_b, T_g, g_i, g_j, A_{ij}, n_j)$  is re-absorption coefficient

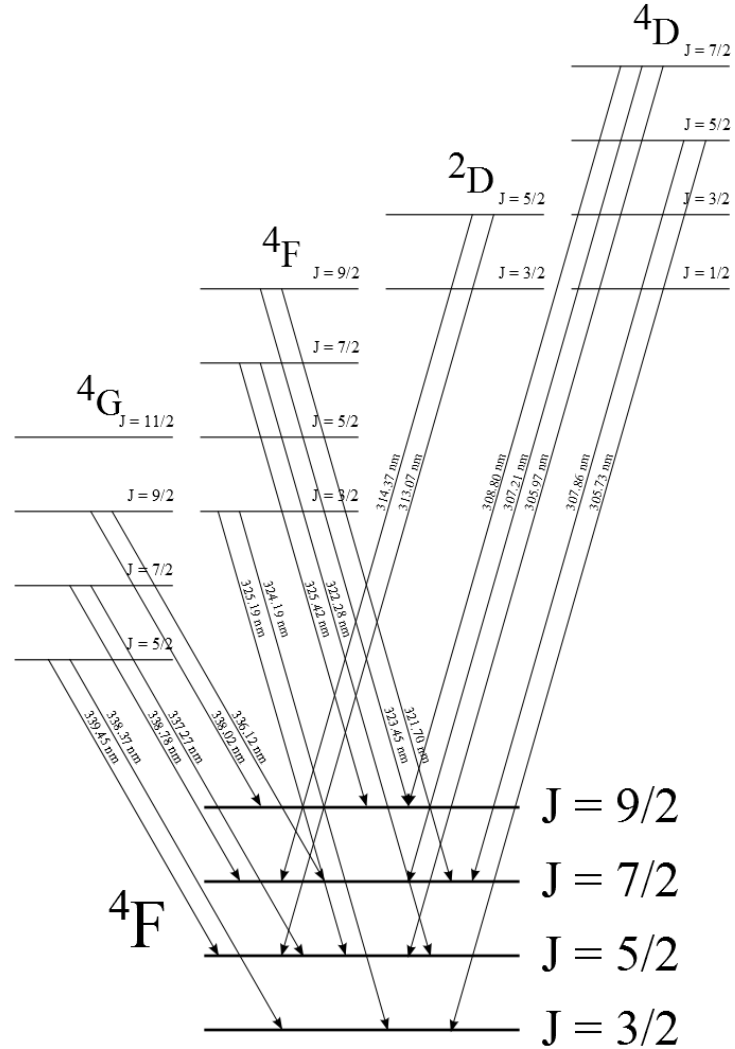
R. Mewe, Br. J. Appl. Phys. **18**, (1967), 107

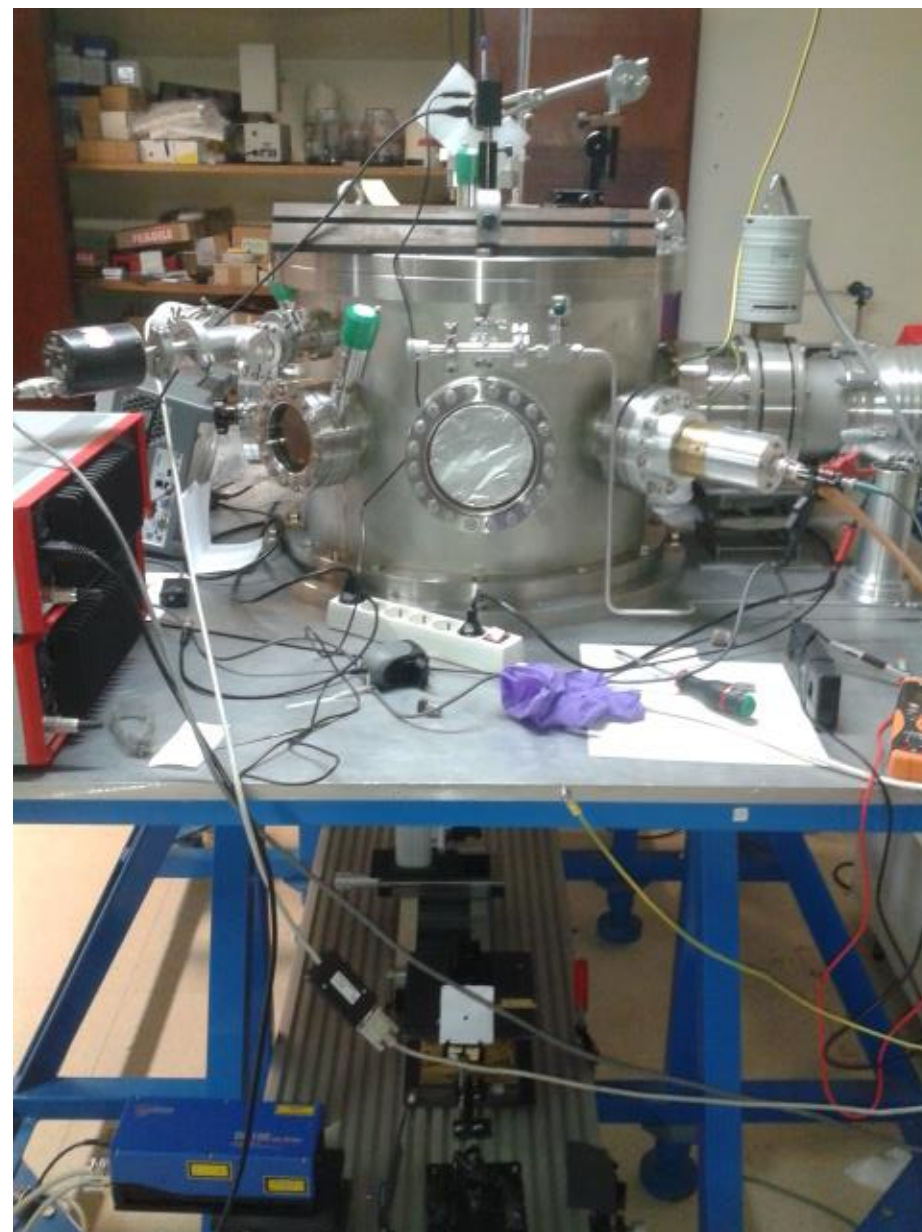
# Self-absorption in titanium plasma – „good“ transitions

13 transitions for Ti

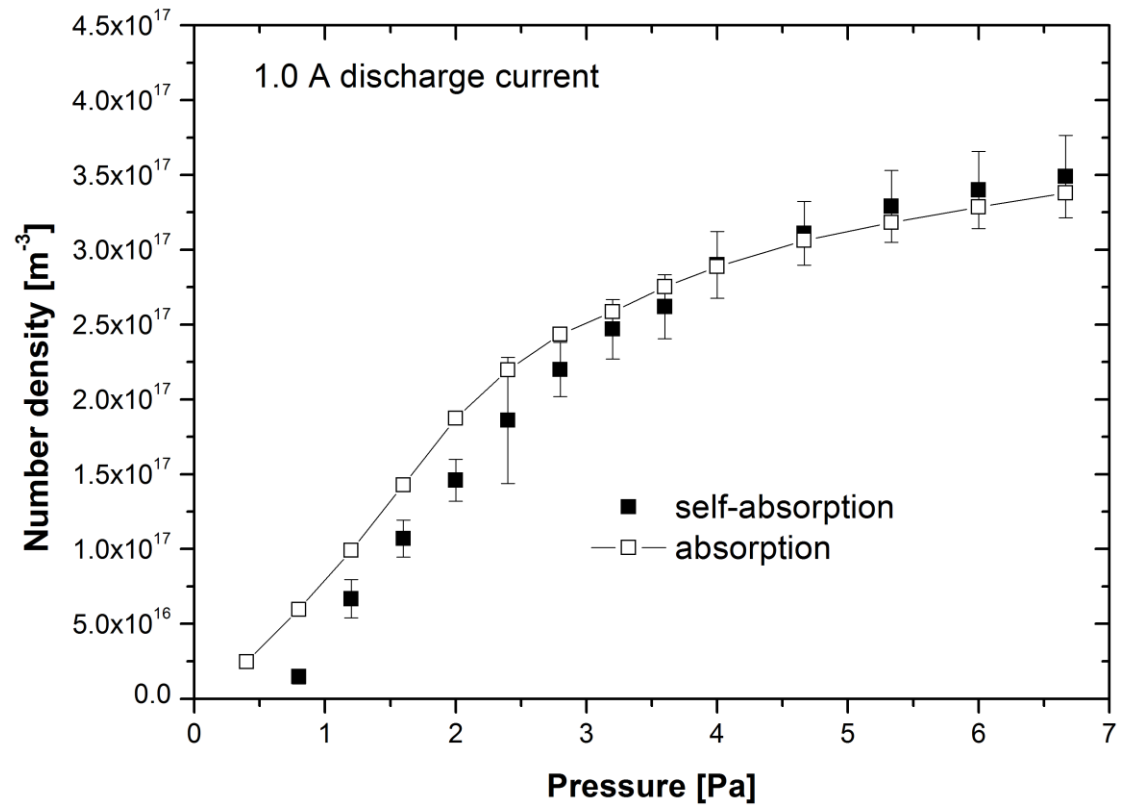
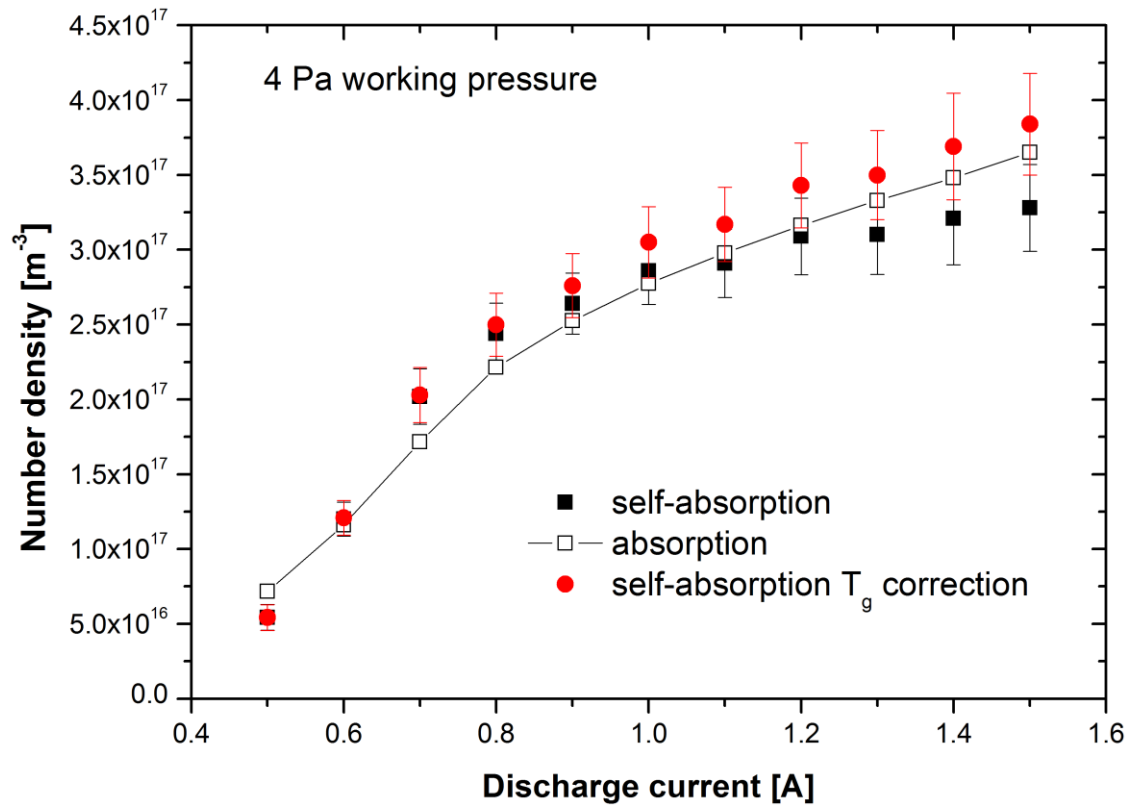


19 transitions for  $Ti^+$

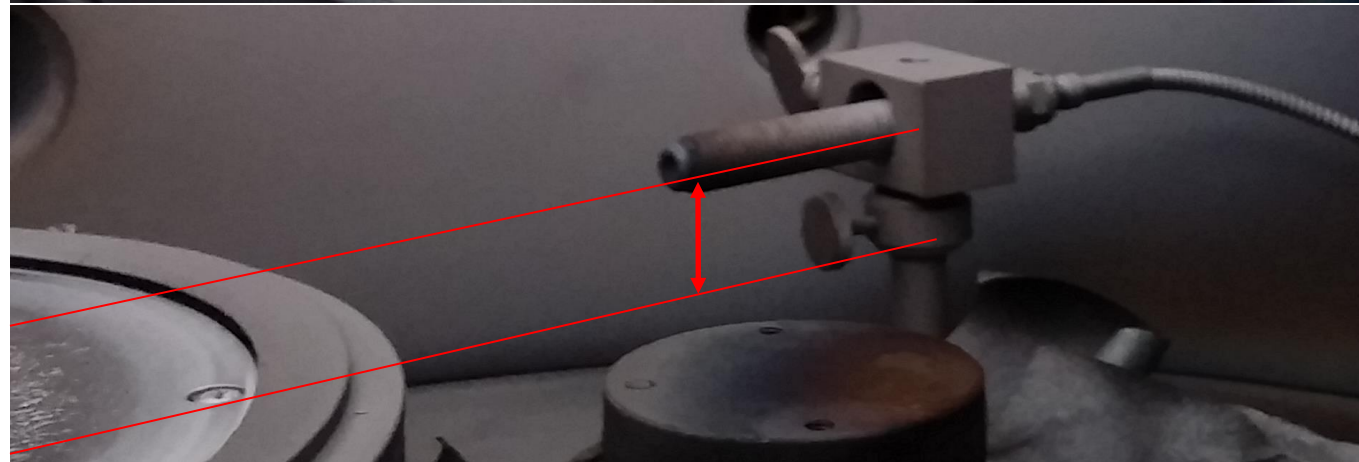
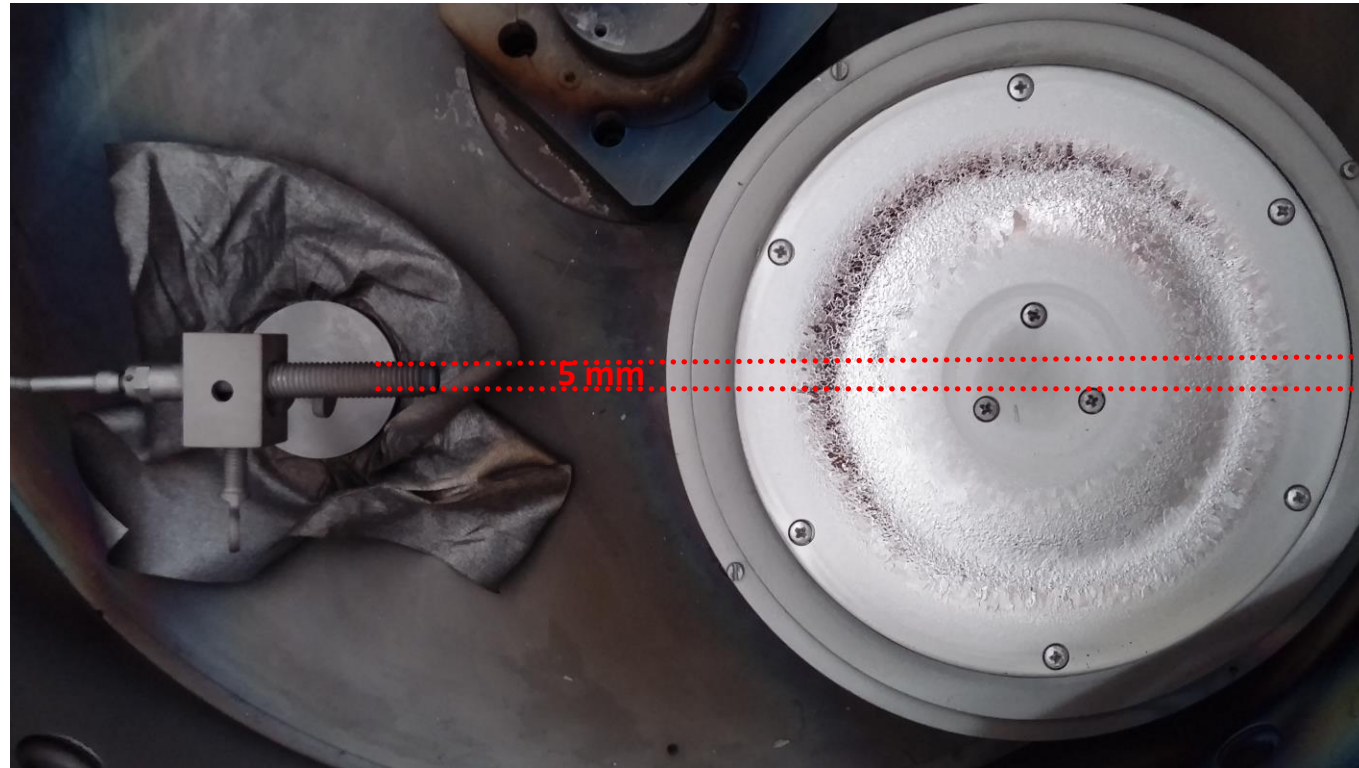


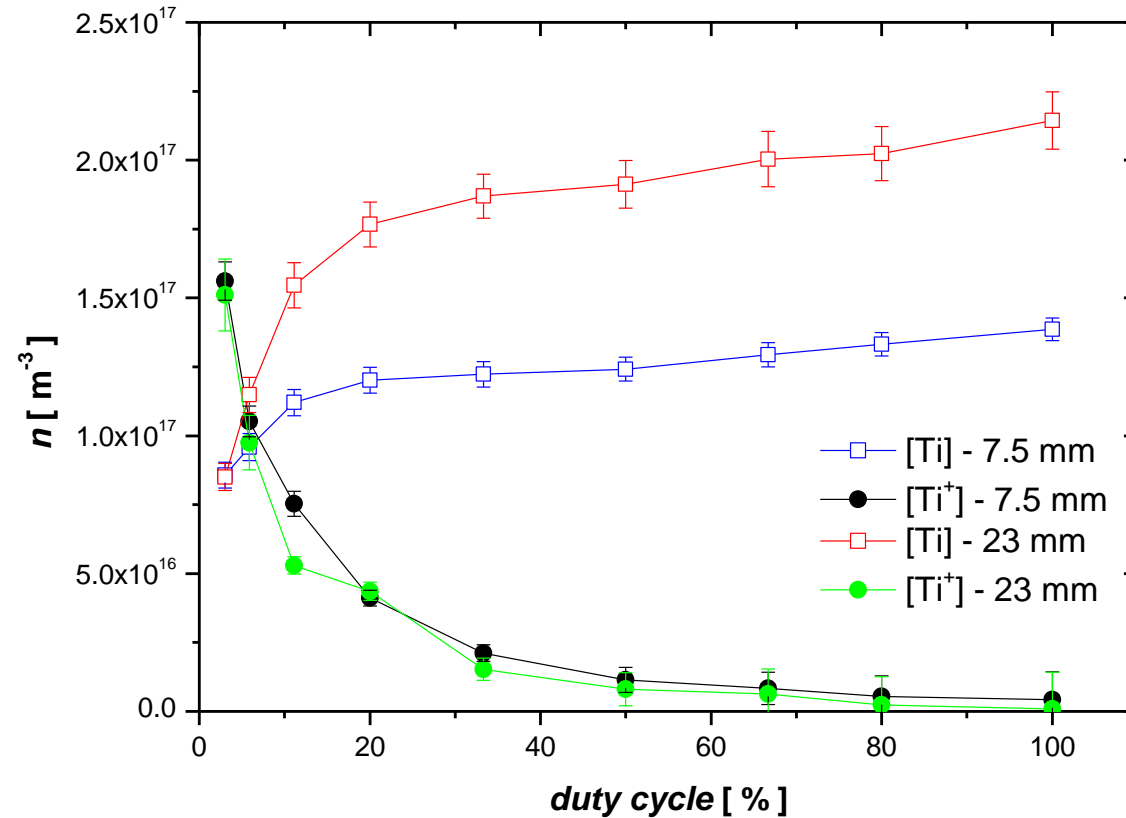






- self-absorption results are **in good agreement** with absorption results



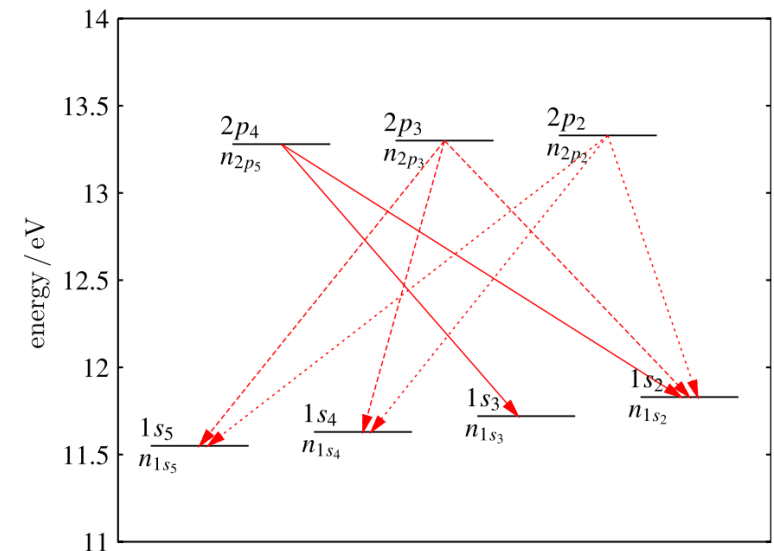


similar ionization fraction in a HIPIMS discharge was observed by:  
 J. Bohlmark et al., J. Vac. Sci. Technol. A **23** (2005) 18  
 S. Konstantinidis et al., J. Appl. Phys. **99** (2006) 013307

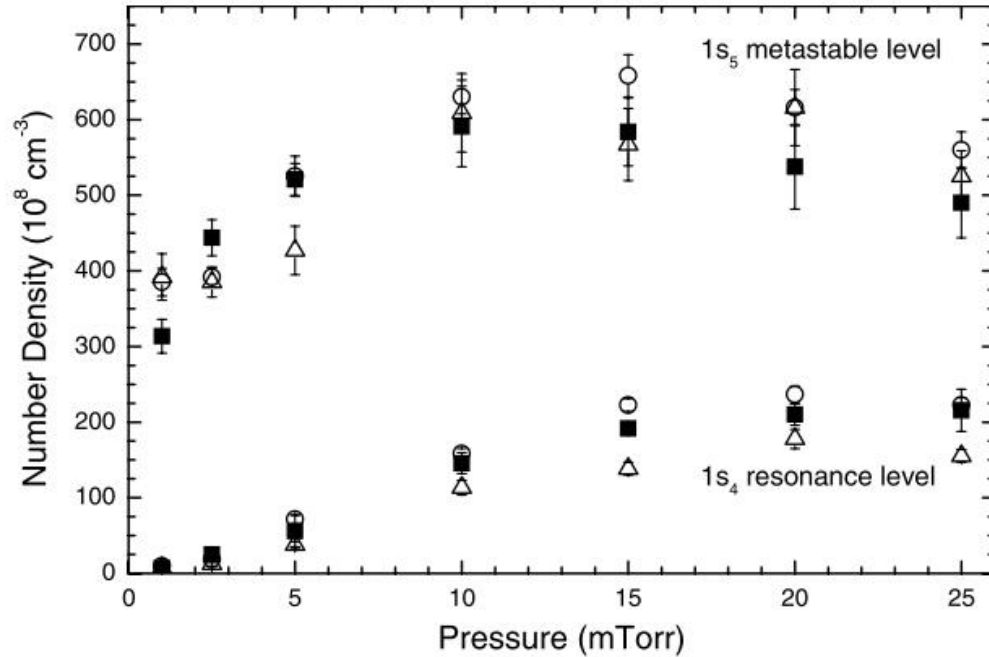
# Self-absorption + EBF in ICP

- Unlike classical self-absorption methods comparing intensities of transitions with the same **lower level**, the effective branching factor (EBF) method compares intensities of transitions from a common **upper level**
- the branching only depends on the **Einstein coefficients** and on **photon reabsorption** and is independent of collision processes, for example collisional de-excitation of the upper state  $i$ . The diagnostic idea is to exploit this branching to determine the population densities of only the lower levels  $j$

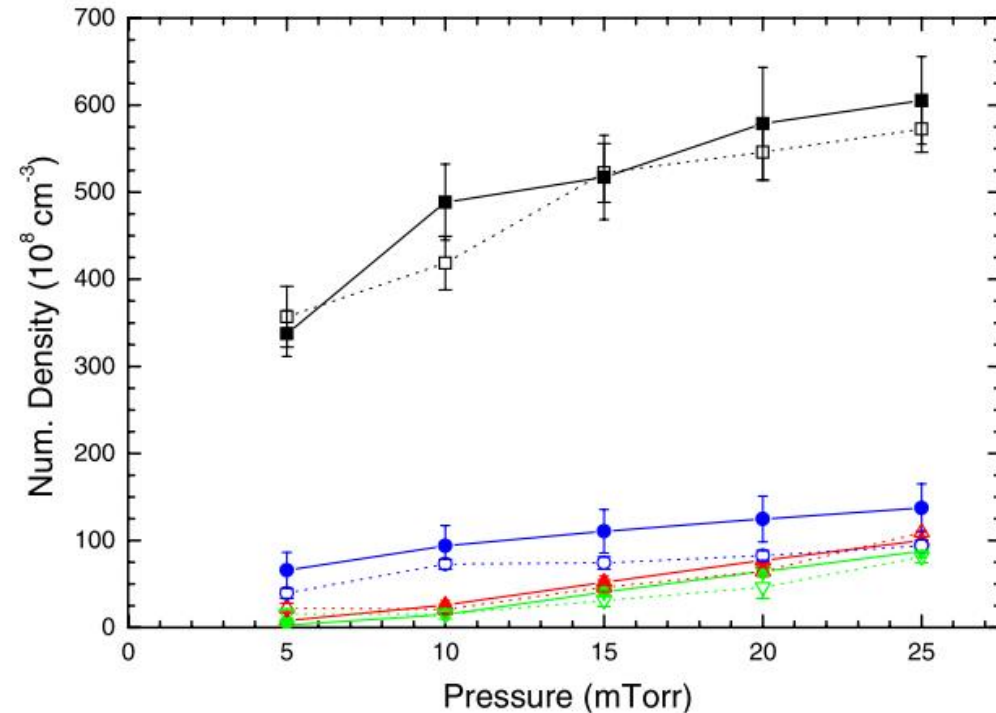
Line	Wavelength (nm)	Transition	$E_{th}$ (eV)	$A_{ij}$ ( $s^{-1}$ )	Lifetime (ns)
Ar-826	826.45	$2p_2 \rightarrow 1s_2$	13.33	$1.53 \times 10^7$	28.4
Ar-727	727.29	$2p_2 \rightarrow 1s_4$	13.33	$1.83 \times 10^6$	28.4
Ar-696	696.54	$2p_2 \rightarrow 1s_5$	13.33	$6.39 \times 10^6$	28.4
Ar-840	840.82	$2p_3 \rightarrow 1s_2$	13.30	$2.23 \times 10^7$	28.9
Ar-738	738.40	$2p_3 \rightarrow 1s_4$	13.30	$8.47 \times 10^6$	28.9
Ar-706	706.72	$2p_3 \rightarrow 1s_5$	13.30	$3.80 \times 10^6$	28.9
Ar-852	852.14	$2p_4 \rightarrow 1s_2$	13.28	$1.39 \times 10^7$	30.4
Ar-794	794.82	$2p_4 \rightarrow 1s_3$	13.28	$1.86 \times 10^7$	30.4
Ar-750	750.38	$2p_1 \rightarrow 1s_2$	13.48	$4.45 \times 10^7$	22.4
Ar-811	811.53	$2p_9 \rightarrow 1s_5$	13.08	$3.31 \times 10^7$	30.2



# Self-absorption + EBF in ICP

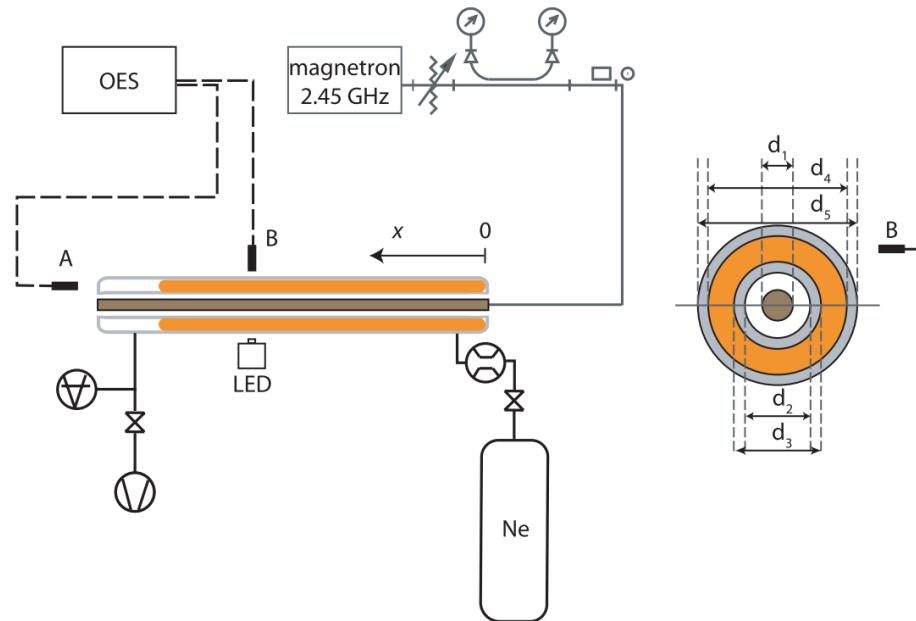


**Figure 7.** Peak number densities for the  $1s_4$  and  $1s_5$  levels in a 600 W Ar plasma using three different techniques: white light absorption ( $\blacksquare$ ), OES branching fraction method of Schulze *et al* ( $\triangle$ ) and OES branching fraction method using entire  $\text{Ar}(3p^5 4p \rightarrow 3p^5 4s)$  transition array ( $\circ$ ).



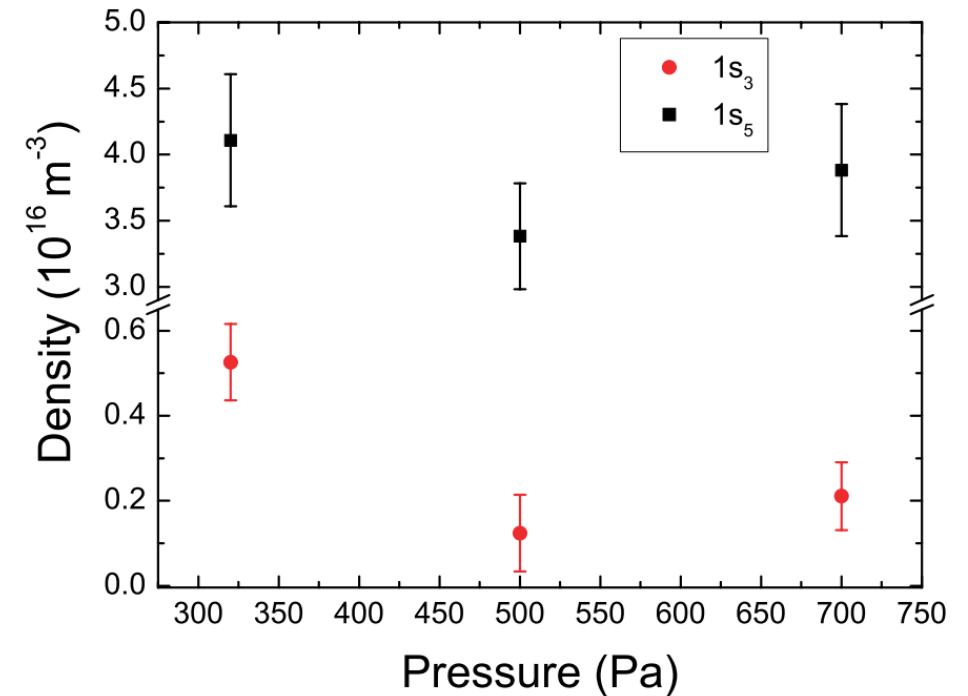
**Figure 8.** 600 W Ne plasma number densities:  $1s_2$  level ( $\blacktriangle, \triangle$ ),  $1s_3$  level ( $\bullet, \circ$ ),  $1s_4$  level ( $\blacktriangledown, \triangledown$ ),  $1s_5$  level ( $\blacksquare, \square$ ). Solid line/points are from absorption measurements, dashed lines/open points are values extracted from branching fraction measurements.

# Self-absorption + EBF in MW discharge



- 60W, 300–700 Pa
- two spectral lines with the same lower level i.e., metastable level
- densities of  $1s_3$  and  $1s_5$  metastable neon states

- $1s_5$  density was determined from the pair of lines with the highest ratio of oscillator strengths 640.2/597.6 ( $f_1/f_2 = 39.1$ )
- $1s_3$  density was obtained from the only one suitable line pair 626.7/743.9 ( $f_1/f_2 = 7.65$ )



# PUMP-PROBE SPECTROSCOPY AND MICROSCOPY

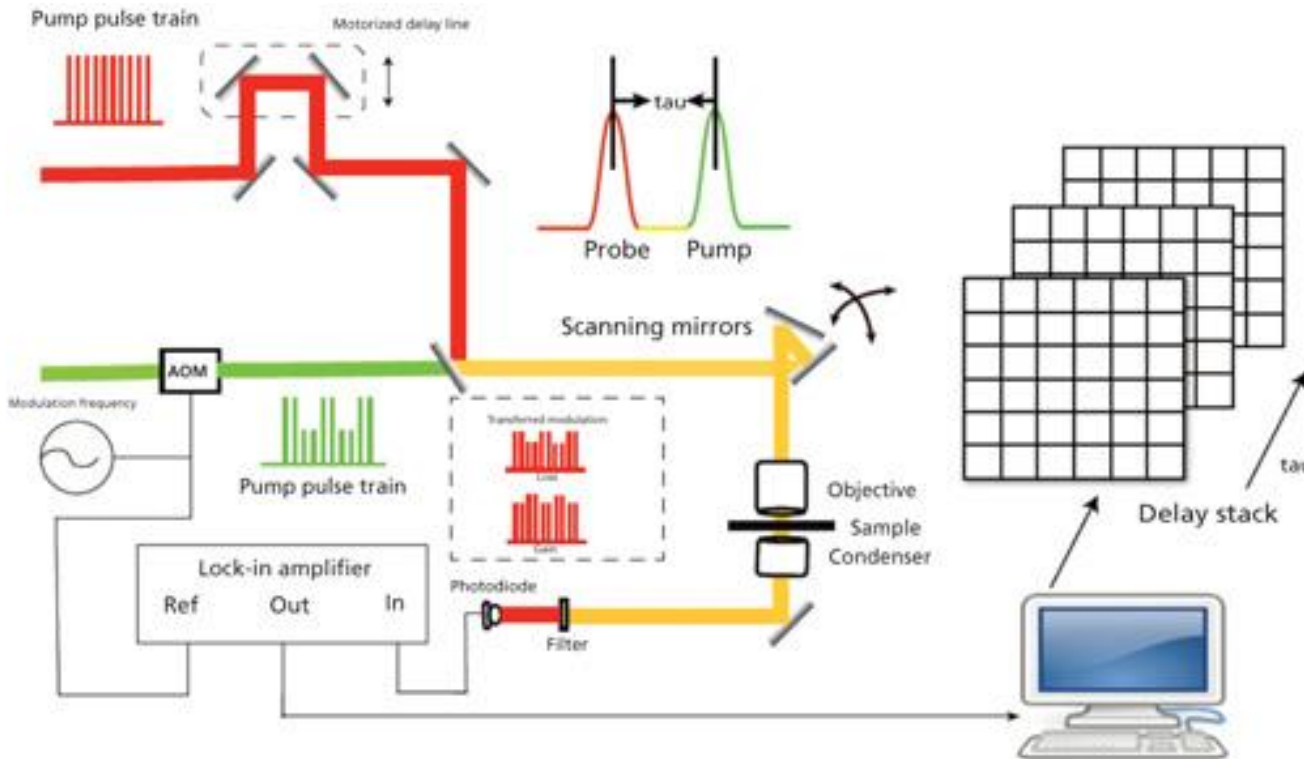


# Pump-probe spectroscopy and microscopy

- **Nobel laureate Ahmed Hassan Zewail** (a pioneer of femtochemistry - ) recorded the snapshots of chemical reactions with sub-angstrom resolution through an ultrafast femtosecond transient absorption technique
- **In a transient absorption experiment, a laser pulse pumps a molecule into an excited state. The excited state itself exhibits relaxation dynamics on the femtosecond ( $10^{-15}$ ) or picosecond ( $10^{-12}$ ) timescale. A second laser pulse then probes the population in the excited state at different temporal delays with respect to the excitation. This analysis method reveals the dynamics of the excited state.**
- Nonlinear optical imaging technique that probes the excited state dynamics, which is related to the third-order nonlinearity
- Measures the change in transmission of a probe beam induced by a pump beam.
- It can monitor the excited-state dynamics, which provides an intrinsic molecular contrast of examined samples
- It is emerging tool for **functional imaging of non-fluorescent chromophores and nanomaterials**
- It has superior detection sensitivity, chemical specificity, and spatial–temporal resolution



# Pump-probe spectroscopy and microscopy



- oscillator pumped by a high-intensity laser generates synchronous pump and probe pulse trains
- probe beam is delayed
- pump beam intensity is modulated with an acousto-optic modulator (AOM), and the intensity of both beams is adjusted through the combination of a half-wave plate and polarizer
- pump and probe beams are collinearly guided into the microscope. After the interaction between the pump beam and the sample, the modulation is transferred to the unmodulated probe beam.
- the mirrors are used to scan the combined lasers in a raster scanning manner to create microscopic images.
- the pump beam is spectrally filtered by an optical filter, and the transmitted probe intensity is detected by a photodiode. A phase-sensitive lock-in amplifier demodulates the detected signal. Therefore, pump-induced transmission changes of the sample versus time delay can be measured from the focus plane. **This change over time delay shows different decay signatures from different chemicals, thus offering the origin of the chemical contrast.**

# Pump-probe spectroscopy and microscopy

- In a typical pump–probe measurement, the pump-induced intensity change of the probe is measured by a lock-in amplifier referenced to the modulated pump pulse. Then this change is normalized by the probe beam intensity to generate  $\Delta I_{pr}/I_{pr}$ .
- Absorption coefficient for an electronic transition between level “ $i$ ” and level “ $j$ ”

$$\alpha_{ij}(\omega) = \sigma_{ij}(\omega) (N_i - N_j)$$

$\sigma_{ij}(\omega)$  is the cross section from electronic state  $i$  to  $j$ , and  $N_i$  and  $N_j$  are the populations of the initial and final states, respectively. Conventionally,  $\alpha$  is positive for absorption and negative for gain.

# Pump-probe spectroscopy and microscopy

The pump pulse acts on the sample by changing the energy level population,  $N \rightarrow (N + \Delta N)$ . Consequently, the population of excited states will increase at the expense of that of the ground state. Such change is measured by the probe beam:

$$\frac{\Delta I_{\text{pr}}}{I_{\text{pr}}} = - \sum_{i,j} \alpha_{ij}(\omega) \Delta N_j d$$

$d$  is the sample thickness. The expression is derived from the Lambert-Beer relation within the small signal approximation. The “ $j$ ” term describes all possible excited states.

# Pump-probe spectroscopy and microscopy

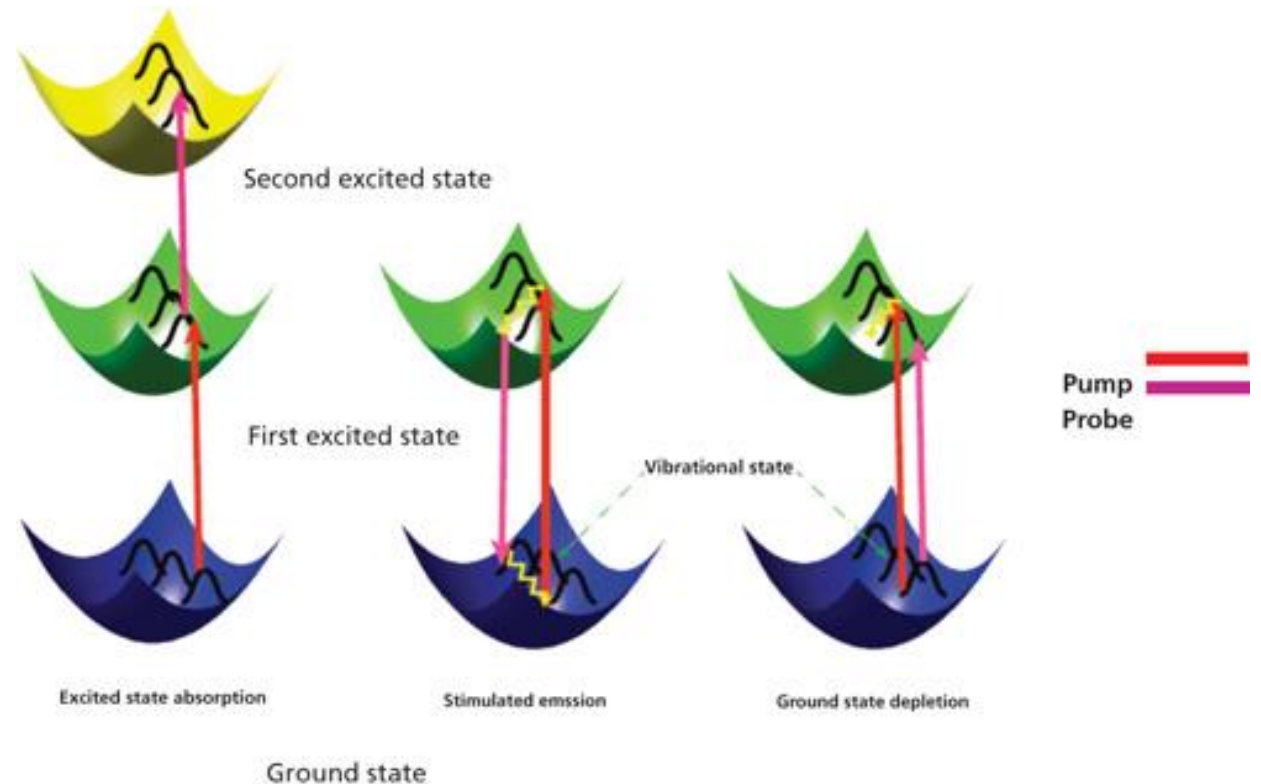
Depending on the probe energy, three effects on the transmitted pulse can be observed:

1. When the probe pulse is resonant with  $i \rightarrow j$  transitions ( $i \neq 0$ ), then the probe pulse is absorbed by the molecule, reducing the transmission of the probe pulse. This negative  $\Delta I_{pr}/I_{pr}$  signal change is therefore called **excited state absorption** (ESA).
2. When the probe pulse is resonant with  $0 \rightarrow j$  transmission, the probe transmission is enhanced upon pump excitation. This positive  $\Delta I_{pr}/I_{pr}$  phenomenon is called **ground-state depletion** (GSD).
3. When the lowest excited state is dipole-coupled to the ground state and the probe pulse is resonant with the transition, **stimulated emission** (SE) occurs. An increased transmission is observed in a SE process.

# Pump-probe spectroscopy and microscopy

Three major processes:

- (a) **excited state absorption** - the probe photons are absorbed by the excited molecules, promoting them to the higher energy levels
- (b) **stimulated emission** - photons in its excited state can be stimulated down to the ground state by an incident light field, thus leading to an increase of transmitted light intensity on the detector
- (c) **ground-state depletion** - the number of the molecules in the ground state is decreased upon photoexcitation, consequently increasing the transmission of the probe pulse



# Pump-probe spectroscopy and microscopy

**Excited-state absorption (ESA)** is a process where the probe photons are attenuated by excited states. Since the 1970s, picosecond laser-based ESA measurements have been extensively used to measure ground and excited-state dynamics. Compared to two-photon absorption, which goes through a virtual intermediate state, excited-state absorption significantly enhances the detection sensitivity by bringing a resonance with a real intermediate electronic state.

$$\Delta I_{\text{pr}} = - \int \frac{N_0 \sigma_{\text{pu}} [\sigma'_{\text{pr}} - \sigma_{\text{pr}}] I_{\text{pu}} I_{\text{pr}} \exp\left(-\frac{\Delta t}{\tau}\right)}{\hbar \nu_{\text{pv}}} dz$$

$N_0$  is the molecular concentration at ground state;  $\sigma_{\text{pr}}$  and  $\sigma'_{\text{pr}}$  are the linear absorption cross sections of the ground state and excited states for the probe beam, respectively;  $\nu_{\text{pv}}$  represents the pump frequency and  $\tau$  is the lifetime of the excited state (assume this is a single-exponential decay); and  $\Delta t$  is the time delay between pump beam and probe beam.  $I_{\text{pu}}$  and  $I_{\text{pr}}$  denote the intensity of pump beam and probe beam.

# Pump-probe spectroscopy and microscopy

When interrogating the short-lived excited states in pump–probe experiments, the photons in the excited states are stimulated down to the ground state by a time-delayed probe pulse. This process is called **stimulated emission**. The absorption coefficient decreases with increasing excitation irradiance. The decrease in absorption happens due to the annihilation of the number densities of both the ground state and the state being excited.

$$\Delta I_{pr} = - \int \frac{N_0 \sigma_{pu} \sigma_{pr} I_{pu} I_{pr} \exp\left(-\frac{\Delta t}{\tau}\right)}{\hbar \nu_{pv}} dz$$

# Pump-probe spectroscopy and microscopy

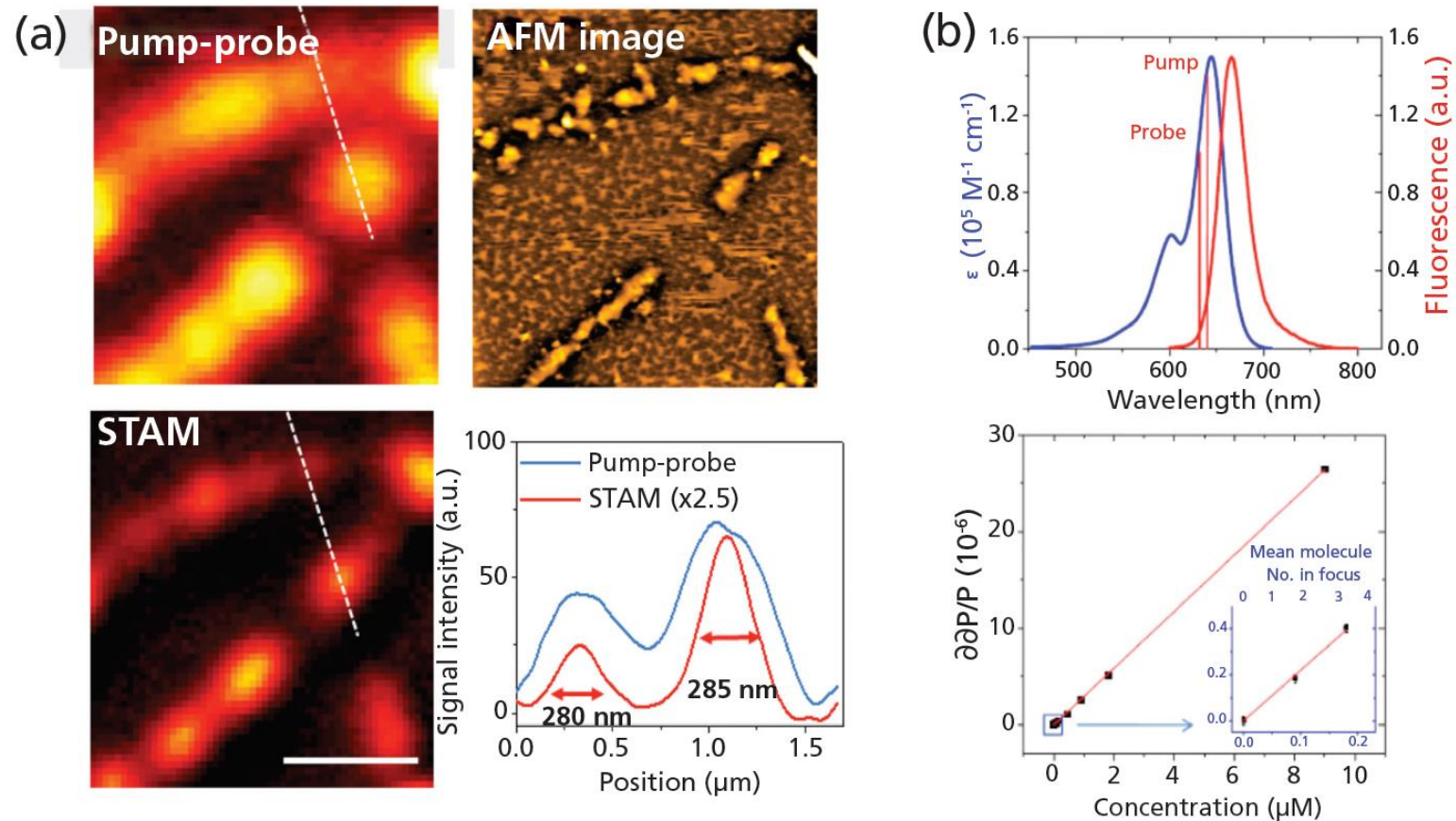
- **Ground-state depletion** (GSD) microscopy is a form of super-resolution light microscopy suggested almost a decade ago, and it was first demonstrated in 2007. Similar to stimulated emission, it presents as an out-phase signal. The overall mechanism is consistent with other transient absorption mechanisms. If expressed in equation form, the GSD process has the same expression as stimulated emission. The only difference lies in the probe wavelength. For GSD, the probe is chosen close to the maximal absorption peak, whereas the probe beam in the case of stimulated emission is selected away from the absorption peak.



# Pump-probe spectroscopy and microscopy

- Pump–probe microscopy = transient absorption microscopy
- **Advantages:**
  1. **nondestructive to cells and tissues** and can be performed without tissue removal
  2. label-free technique and doesn't need an exogenous target
  3. nonlinear optical technique, pump–probe microscopy **can image endogenous pigments** with three dimensional (3-D) spatial resolution
  4. unlike linear absorption, which suffers from scattering in a tissue sample, the pump–probe technique only measures absorption at the focal plane, which offers optical sectioning capability
  5. compared to scattering measurements, this absorption-based method has a weaker dependence on the particle and thus is **highly sensitive to nanoscale subjects**
  6. pump–probe microscopy with near-infrared laser pulses permits **biological applications with an enhanced penetration depth and a lower level of tissue damage**

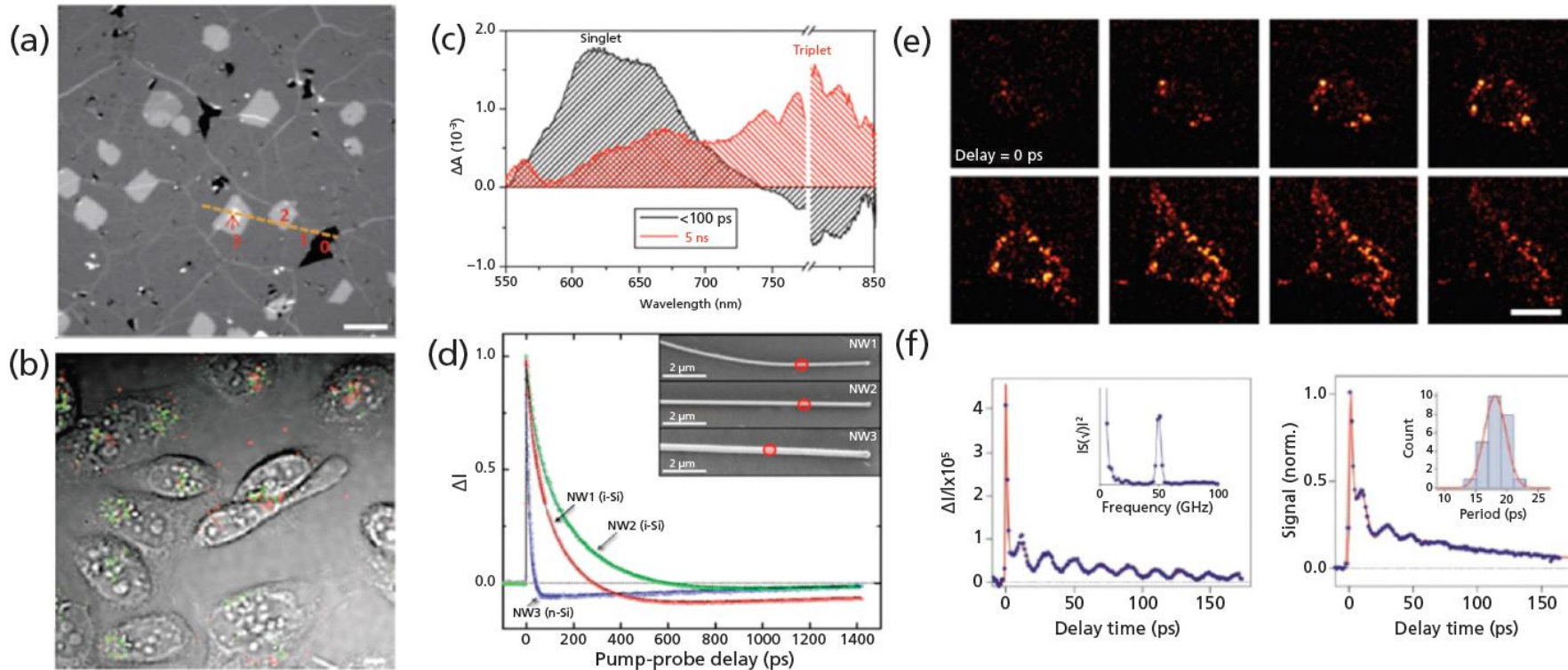
# Pump-probe spectroscopy and microscopy



(a) Image from transient absorption microscopy and AFM image of **graphite nanoplatelets**. Image from saturation TA microscopy (bottom left) and intensity profiles along the lines indicated by the dashed lines in pump-probe image and STAM image (bottom right).

(b) Ground-state depletion microscopy with detection sensitivity of single-molecule at room temperature. Ensemble absorption and emission spectra of Atto647N in pH = 7 aqueous solution (top). The wavelengths of pump and probe beams are indicated. Ground-state depletion signal as a function of concentration of aqueous Atto647N solution (bottom). The blue frame shows the points at lowest concentrations, indicating **single molecule sensitivity is reachable**.

# Pump-probe spectroscopy and microscopy



(a) imaging of **graphene** on glass coverslip

(b) DNA-SWNTs internalized by CHO cells after 24 h incubation

(c) decay-associated spectra of the triplet (red) and singlet (black) excitons of tetracene obtained by global analysis of the ensemble transient absorption spectra with the probe polarization to maximize triplet absorption.

(d) decay kinetics following photoexcitation of a localized region in three different Si nanowires

(e) 3D transient absorption microscopic **images of gold nanodiamonds in living cells**

(f) trace from a single **Ag nanocube**

# Pump-probe spectroscopy and microscopy

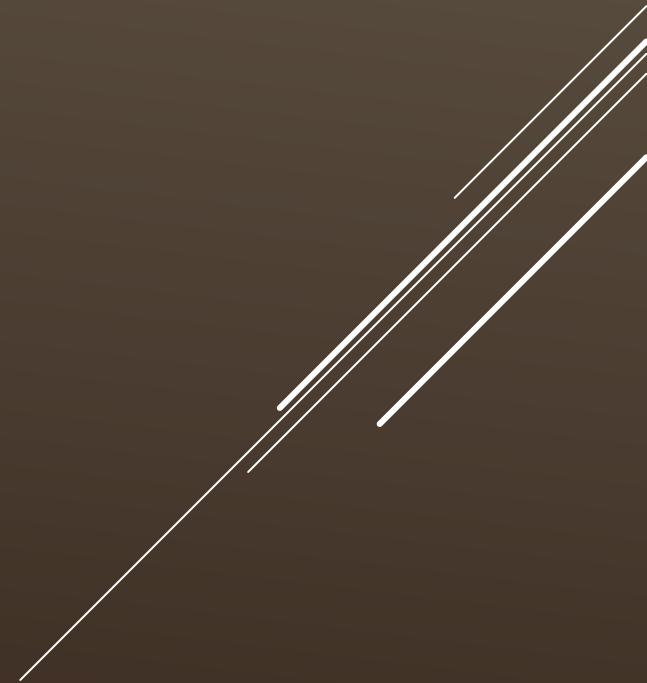
## Application:

- measuring fluorescence lifetime
- imaging melanin by using two-color two-photon absorption or excited state absorption processes
- applications to pigments in biological tissue
- characterization of single nanostructures including gold nanorods and single-wall nanotubes
- distinguish semiconducting carbon nanotubes from metallic ones
- imaging semiconducting and metallic nanotubes in living cells

## Outlook:

- compact and low-cost pump–probe microscopy will be developed and made commercially available for broad use of this technique by nonexperts
- handheld pump–probe imaging system will be developed to assist precision surgery in the clinic
- to study the decay kinetics are used to study cellular development and disease stage
- broad use in biology, medicine, and materials science

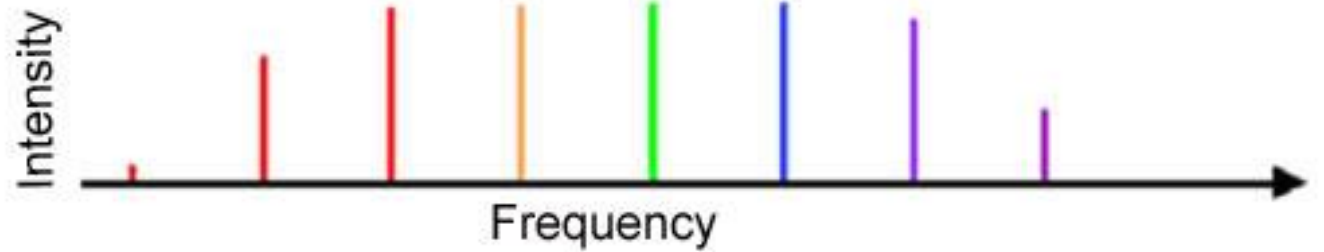
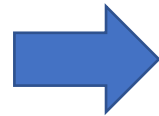
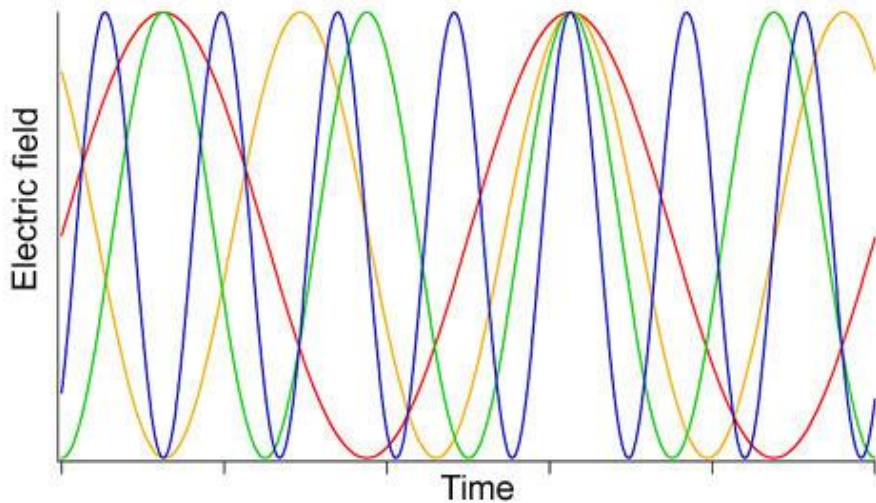
# OPTICAL FREQUENCY COMB TECHNIQUE



# Optical frequency comb technique

- Optical frequency combs are produced by femtosecond mode-locked lasers, whose optical spectrum consists of a series of equidistant narrow lines spanning tens or hundreds of nanometers.
- Spectroscopy performed with optical frequency combs is equivalent to a simultaneous measurement with thousands of narrow synchronized laser lines. The unique combination of **large bandwidth** and **high spectral resolution** provided by optical frequency combs makes them suitable not only for precision spectroscopy but also for highly sensitive multi-species detection of molecular constituents in the gas phase.
- **Nobel prize (2005) for their contributions to the development of laser-based precision spectroscopy including the optical frequency comb technique – J. Hall, T.W. Hänsch**
- J. Hall and colleagues developed methods to stabilize lasers and a "self-referencing" technique that ensures the comb teeth are in exactly the right places. This involves taking two measurements from different parts of a very broad comb and comparing the results to precisely known frequencies of an atomic clock.
- It is a very precise tool for measuring different colors or frequencies of light. The technology, made possible by recent advances in ultrafast lasers, can accurately measure much higher frequencies than any other tool.
- It relies on the relationship between time and frequency (**simply the number of oscillations per unit of time**). The properties of the light over time are converted to frequency numbers to make what looks like a comb. Time and frequency are inversely related; that is, smaller units of time (or faster oscillations of light waves) result in larger frequency numbers.

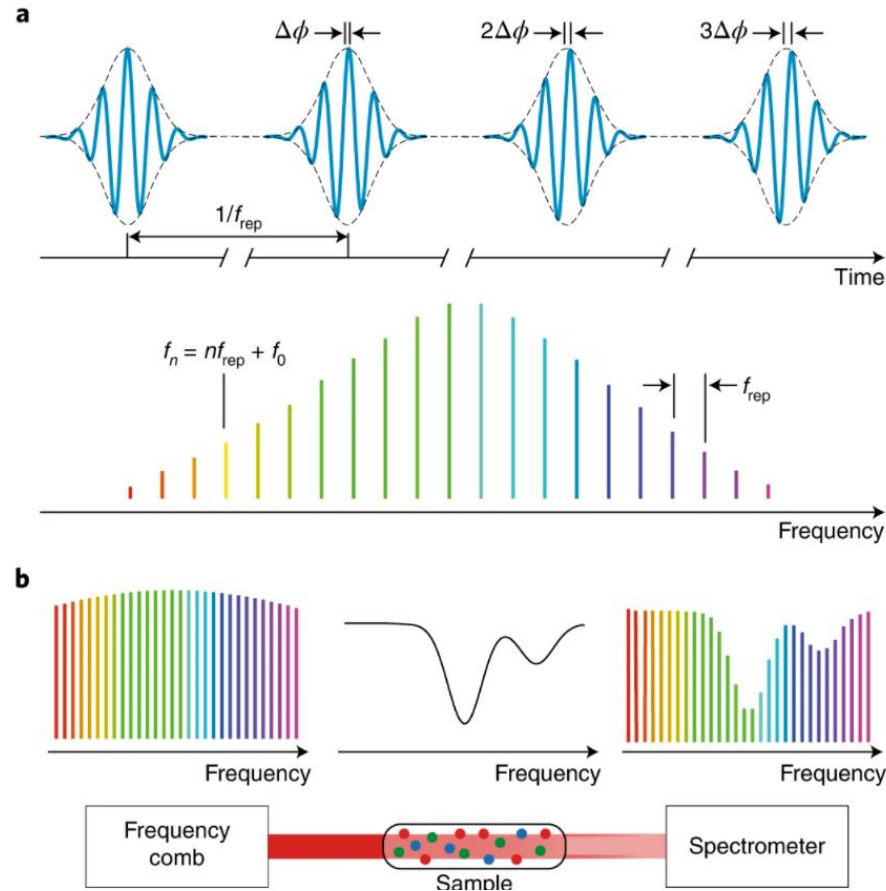
# Optical frequency comb technique



Example of a few different colors of light oscillate over time. This example is greatly simplified, and the specific units are unimportant. The essential point is that the blue waves oscillate much faster than the red waves, and the yellow and green waves are somewhere in between.

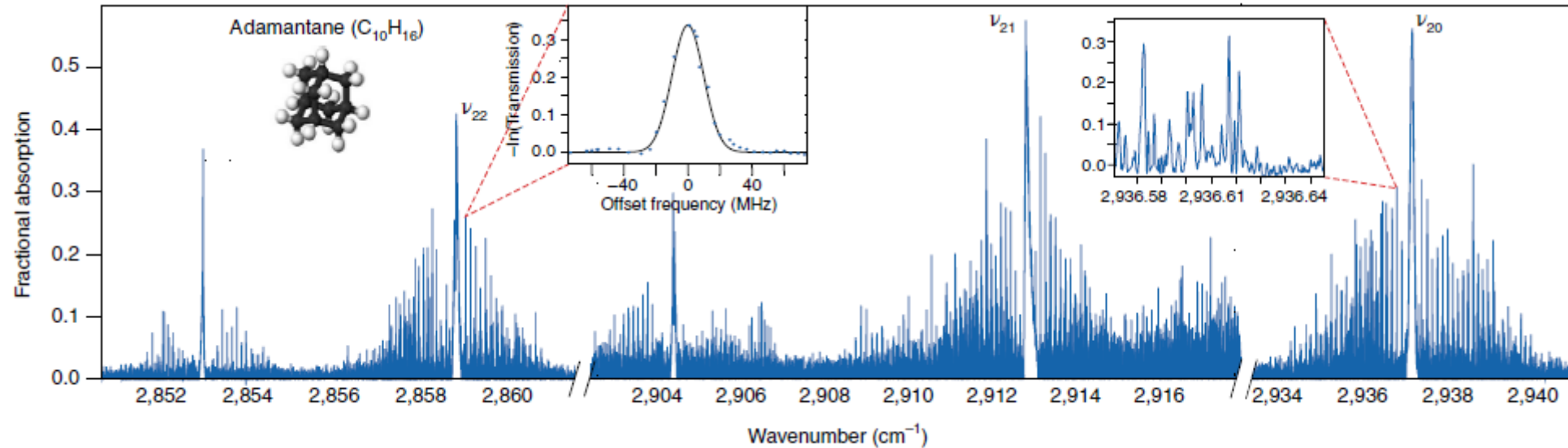
A simplified graphic of a corresponding frequency comb. Each "tooth" of the comb is a different color, arranged according to how fast the light wave oscillates in time. The waves that oscillate slowly (red) are on the left and the waves that oscillate faster (blue) are on the right. Frequency is measured in hertz, or cycles per second.

# Optical frequency comb technique



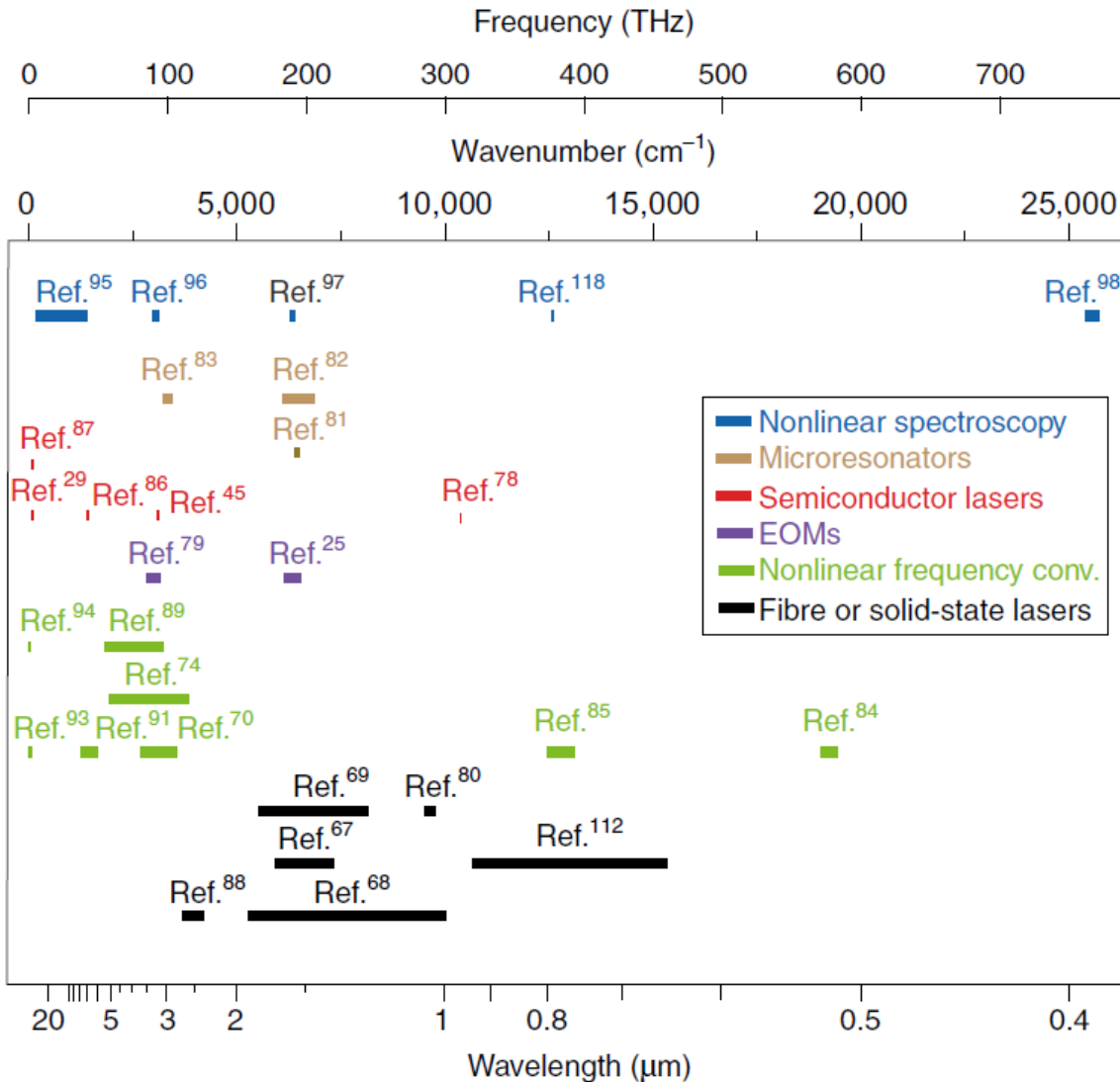


# Optical frequency comb technique



Cavity-enhanced frequency comb Fourier transform spectrum of buffer-gas cooled adamantane ( $C_{10}H_{16}$ ) in the 3  $\mu\text{m}$  region, at a translational temperature of 17 K and a spectral resolution of 10 MHz. The two insets are magnifications, illustrating the narrow width of the lines and good resolution.

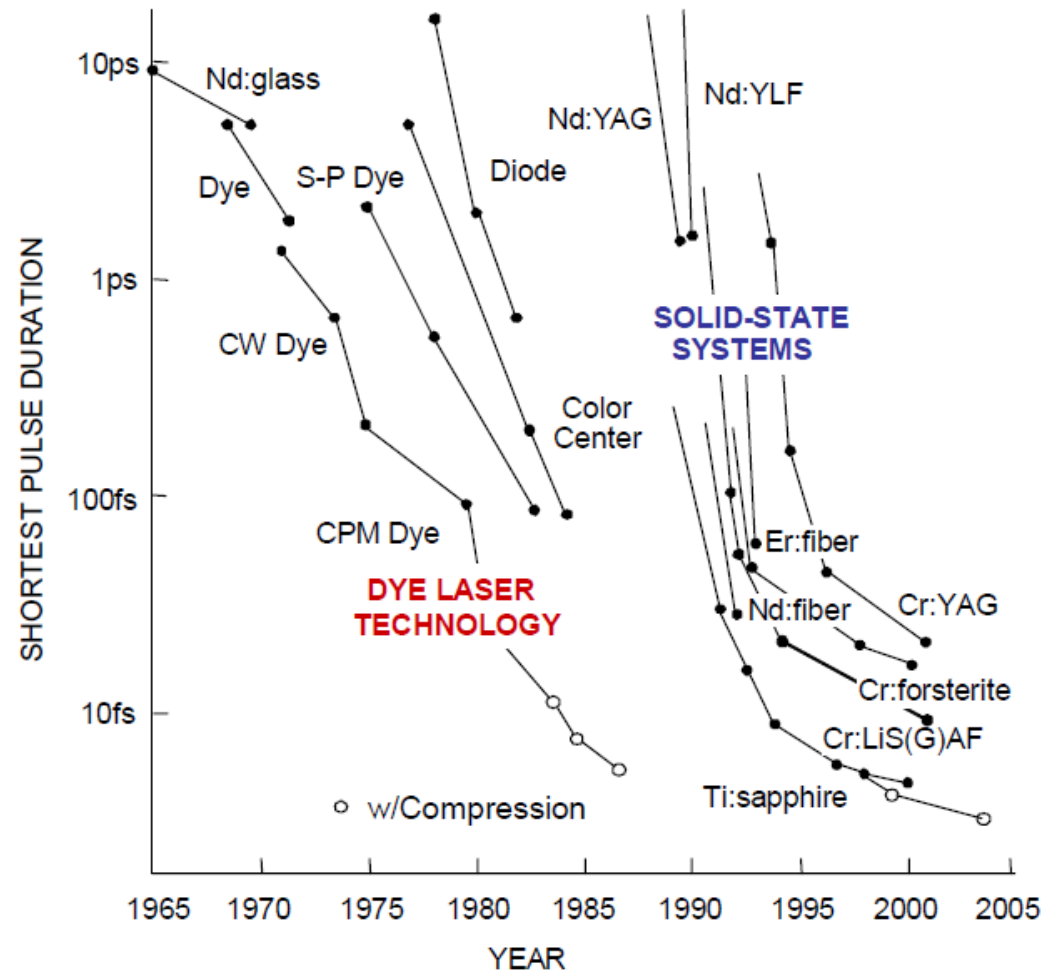
# Optical frequency comb technique



## Spectral coverage of dual-comb spectroscopy

Overview of the spectral regions where experiments of dual-comb spectroscopy have been reported. The spans, which represent the entire tunability range rather than the span that can be covered in a single recording, are taken from a selection of references cited in the manuscript. Some of these experiments were performed as proofs of concept, with combs that were not mutually coherent. The color code distinguishes the few experiments of nonlinear spectroscopy as well as the type of frequency comb synthesizers that were used in linear spectroscopy. Nonlinear frequency conv. means nonlinear frequency conversion of near-infrared fiber or solid-state mode-locked lasers and includes difference-frequency generation, optical parametric oscillation and second-harmonic generation. EOMs, electro-optic modulators.

# Optical frequency comb technique



# Optical frequency comb technique

- **Titanium-doped sapphire** ( $\text{Ti}^{3+}$ :sapphire) is a widely used transition-metal-doped gain medium for tunable lasers and **femtosecond solid-state lasers**
- Generation of femtosecond pulses with solid state lasers has followed from the discovery of self-mode-locking in a Ti:sapphire laser, which is explained as a consequence of self-focusing inside the laser
- Mode-locking refers to how the laser light is formed into pulses. In all lasers, light is repeatedly reflected within a mirrored cavity. In a mode-locked laser, the peaks of the different colors of light waves coincide at regular intervals, evenly spaced in time. The peaks build on each other to form very short, bright bursts of light, each containing many different frequencies
- The  $\text{Ti}^{3+}$  ion has a very large gain bandwidth allowing the generation of very short pulses and also wide wavelength tunability. The maximum gain and laser efficiency are obtained around 800 nm. The possible tuning range is 650 to 1100 nm, but different mirror sets are normally required for covering this huge range
- Upper-state lifetime of Ti:sapphire is 3.2  $\mu\text{s}$ , and the saturation power is very high
- Pulse duration around 100 fs is easily achieved and is typical for commercial devices. However, even pulse durations around 10 fs are possible for commercial devices, and the shortest pulses obtained in research laboratories have durations around 5.5 fs.
- Typical output powers are of the order of 0.3–1 W, whereas continuous-wave versions sometimes generate several watts. A typical pulse repetition rate is 80 MHz, but devices with multi-gigahertz repetition rates are also commercially available

# Optical frequency comb technique

- **Broad frequency range:** it could span 125,000 frequency components of light, or 100 nanometers (750-850 nm) in the visible and near-infrared wavelength range, enabling scientists to observe all the energy levels of a variety of different atoms and molecules simultaneously.
- **Precision:** High resolution or precision allows scientists to separate and identify signals that are very brief or close together, such as individual rotations out of hundreds of thousands in a water molecule. The resolution can be tweaked to reach below the limit set by the thermal motion of gaseous atoms or molecules at room temperature.
- **High sensitivity:** currently 1 molecule out of 100 million—enables the detection of trace amounts of chemicals or weak signals. With additional work, building a portable tool providing detection capability at the 1 part per billion level could be reached. Such a device might be used, for example, to analyze a patient's breath to monitor diseases such as renal failure and cystic fibrosis.
- **Fast data:** acquisition time of about 1 millisecond per 15 nm of bandwidth enables scientists to observe what happens under changing environmental conditions, and to study molecular vibrations, chemical reactions, and other dynamics.

# Optical frequency comb technique

- Frequency combs have dramatically simplified and improved the accuracy of frequency metrology. They also are making it possible to build optical atomic clocks, expected to be as much as 100 times more accurate than today's best time-keeping systems. Better clocks will lead to studies of, for example, the stability of the constants of nature over time, and enable improved technology for advanced communications and precision navigation systems, such as next-generation global positioning systems.
- Highly accurate measurements of frequencies are also essential for many other advanced fields of science that require the identification or manipulation of atoms or molecules, such as detection of toxic biochemical agents, studies of ultrafast dynamics and quantum computing. As scientists continue to improve frequency comb technology and make it easier to use, it may be applied in many other research fields and technologies, from medical tests in doctor's offices, to synchronization of advanced telecommunications systems, to remote detection and range measurements for manufacturing or defense applications.

# Optical frequency comb technique

- Optical frequency combs are used to replace transfer cavities and absorption spectroscopy cells in cold atom experiments. A prominent example is the laser cooling transition in  $40\text{Ca}^+$  at 397 nm, where a direct lock of the cooling laser to a frequency comb is performed. This results in higher accuracy and stability than with previous methods. Further, it offers much higher flexibility in regard to future requirements.
- In precision length metrology optical frequency combs system is used to trace back the Helium-Neon laser wavelengths at 543 nm and 633 nm to the SI-second. In the actual measurement, interferometers use both wavelengths simultaneously to measure absolute distances over several orders of magnitude. Having the lasers stabilized to the frequency comb allows for highest accuracy and stability.
- The quest for the most accurate clock is an extreme challenge. In the measurements, they compare distant clock transitions in the ultraviolet, visible, and infrared via the frequency comb to determine which clock has the best stability and accuracy, and improve the current standard. Currently, the strontium lattice clock is one candidate in the race for the world record in stability.

# Optical frequency comb technique

- With an optical frequency comb any frequency in the visible and infrared can be generated. Only a small amount of laser light is required for the lock to the frequency comb, and it couldn't be simpler. For example,  $^{87}\text{Rb}$  atoms require light at specific wavelengths around 480 nm to pump the atoms into the Rydberg state. With the frequency comb, any laser wavelength required can be selected and thus any level be populated.
- Optical frequency combs are inevitable for fundamental tests of various physical quantities. A prime example is the comparison of radio frequencies with optical clock transitions. In 2015 and 2016, frequency combs system were on board of TEXUS sounding rockets 51 and 53. During the flights, all systems had to withstand conditions of 13 g of acceleration before experiencing 360 s of microgravity. Einstein's Equivalence Principle was verified using a Rubidium clock at 780 nm. For final proof, after the landing with 40 g impacts, the combs were recovered and found ready to go again.
- Also used in chemistry laboratories, environmental monitoring stations, security sites screening for explosives or biochemical weapons, and medical offices where patients' breath is analyzed to monitor disease
- It is used to precisely measure and identify the light absorption signatures of many different atoms and molecules



ESR SPECTROMETRY, TAS, XAFS,  
MÖSSBAUER SPECTROSCOPY



# Mössbauer spectroscopy

- is a spectroscopic technique based on the Mössbauer effect. This effect, discovered by Rudolf Mössbauer (also Moessbauer, German: "Mößbauer") in 1958, consists in the nearly recoil-free, **resonant absorption and emission of gamma rays in solids**.
- like nuclear magnetic resonance spectroscopy, **Mössbauer spectroscopy probes tiny changes in the energy levels of an atomic nucleus** in response to its environment.
- typically, three types of nuclear interactions may be observed:
  1. isomer shift, also called chemical shift in the older literature
  2. quadrupole splitting
  3. magnetic hyperfine splitting (see also the Zeeman effect)
- due to the high energy and extremely narrow line widths of gamma rays, Mössbauer spectroscopy is a very sensitive technique in terms of energy (and hence frequency) resolution, capable of detecting changes in just a few parts per  $10^{11}$

# Mössbauer spectroscopy

- **A solid sample is exposed to a beam of gamma radiation, and a detector measures the intensity of the beam transmitted through the sample.** The atoms in the source emitting the gamma rays must be of the same isotope as the atoms in the sample absorbing them.
- If the emitting and absorbing nuclei were in identical chemical environments, the nuclear transition energies would be exactly equal and resonant absorption would be observed with both materials at rest. The difference in chemical environments, however, causes the nuclear energy levels to shift in a few different ways. Although these **energy shifts are tiny** (often less than a **micro-electron-volt**), the extremely narrow spectral linewidths of gamma rays for some radionuclides make the small energy shifts correspond to large changes in absorbance. To bring the two nuclei back into resonance it is necessary to change the energy of the gamma ray slightly, and in practice this is always done using the relativistic Doppler effect.
- In the resulting spectra, gamma ray intensity is plotted as a function of the source velocity. At velocities corresponding to the resonant energy levels of the sample, a fraction of the gamma rays are absorbed, resulting in a drop in the measured intensity and a corresponding dip in the spectrum. The number, positions, and intensities of the dips (also called peaks; dips in transmitted intensity are peaks in absorbance) provide information about the chemical environment of the absorbing nuclei and can be used to characterize the sample.

# ESR spectrometry

- Electron paramagnetic resonance (EPR) or electron spin resonance (ESR) spectroscopy is a method for studying materials with unpaired electrons. The basic concepts of EPR are analogous to those of nuclear magnetic resonance (NMR), but **it is electron spins that are excited** instead of the spins of atomic nuclei. EPR spectroscopy is particularly useful for studying metal complexes or organic radicals.
- ESR spectrometer is principally designed to measure **the absorption of electromagnetic waves by a sample substance in a magnetic field**. This absorption occurs at the fulfillment of resonance of the matching radiation frequency  $f$  and the correct magnetic field strength  $H$ , with the Landé factor of the free electron  $g$  and Bohr's magneton  $\mu_B$ , being the central ESR resonance condition described as follows
- theoretically, a suitable magnetic field strength can be generated at almost all frequencies  $f$ . However, for reasons of sensitivity, ESR measurements are usually carried out in the microwave range between 3 and 35 GHz. A basic ESR spectrometer includes a microwave generator, a magnetic field generator and the microwave sensor to measure the absorption. The sample is placed in the resonator.

# Total absorption spectroscopy – TAS

- Total absorption spectroscopy is a measurement technique that allows **the measurement of the gamma radiation emitted in the different nuclear gamma transitions** that may take place in the daughter nucleus after its unstable parent has decayed by means of the beta decay process. This technique can be used for beta decay studies related to beta feeding measurements within the full decay energy window for nuclei far from stability.

# X-ray absorption spectroscopy

- is a specific structure observed in X-ray absorption spectroscopy (XAS). By analyzing the XAFS, **information can be acquired on the local structure and on the unoccupied local electronic states**
- X-ray absorption edge spectroscopy corresponds to the transition from a core-level to an unoccupied orbital or band and mainly reflects the electronic unoccupied states.